



# **Administering Avaya IP Office™ Platform with Manager**

Release 11.1.1  
Issue 28.1.1  
June 2021

© 2021, Avaya Inc.  
All Rights Reserved.

## Notice

While reasonable efforts have been made to ensure that the information in this document is complete and accurate at the time of printing, Avaya assumes no liability for any errors. Avaya reserves the right to make changes and corrections to the information in this document without the obligation to notify any person or organization of such changes.

## Documentation disclaimer

"Documentation" means information published in varying mediums which may include product information, operating instructions and performance specifications that are generally made available to users of products. Documentation does not include marketing materials. Avaya shall not be responsible for any modifications, additions, or deletions to the original published version of Documentation unless such modifications, additions, or deletions were performed by or on the express behalf of Avaya. End User agrees to indemnify and hold harmless Avaya, Avaya's agents, servants and employees against all claims, lawsuits, demands and judgments arising out of, or in connection with, subsequent modifications, additions or deletions to this documentation, to the extent made by End User.

## Link disclaimer

Avaya is not responsible for the contents or reliability of any linked websites referenced within this site or Documentation provided by Avaya. Avaya is not responsible for the accuracy of any information, statement or content provided on these sites and does not necessarily endorse the products, services, or information described or offered within them. Avaya does not guarantee that these links will work all the time and has no control over the availability of the linked pages.

## Warranty

Avaya provides a limited warranty on Avaya hardware and software. Refer to your sales agreement to establish the terms of the limited warranty. In addition, Avaya's standard warranty language, as well as information regarding support for this product while under warranty is available to Avaya customers and other parties through the Avaya Support website: <https://support.avaya.com/helpcenter/getGenericDetails?detailId=C20091120112456651010> under the link "Warranty & Product Lifecycle" or such successor site as designated by Avaya. Please note that if You acquired the product(s) from an authorized Avaya Channel Partner outside of the United States and Canada, the warranty is provided to You by said Avaya Channel Partner and not by Avaya.

"Hosted Service" means an Avaya hosted service subscription that You acquire from either Avaya or an authorized Avaya Channel Partner (as applicable) and which is described further in Hosted SAS or other service description documentation regarding the applicable hosted service. If You purchase a Hosted Service subscription, the foregoing limited warranty may not apply but You may be entitled to support services in connection with the Hosted Service as described further in your service description documents for the applicable Hosted Service. Contact Avaya or Avaya Channel Partner (as applicable) for more information.

## Hosted Service

THE FOLLOWING APPLIES ONLY IF YOU PURCHASE AN AVAYA HOSTED SERVICE SUBSCRIPTION FROM AVAYA OR AN AVAYA CHANNEL PARTNER (AS APPLICABLE), THE TERMS OF USE FOR HOSTED SERVICES ARE AVAILABLE ON THE AVAYA WEBSITE, [HTTPS://SUPPORT.AVAYA.COM/LICENSEINFO](https://support.avaya.com/licenseinfo) UNDER THE LINK "Avaya Terms of Use for Hosted Services" OR SUCH SUCCESSOR SITE AS DESIGNATED BY AVAYA, AND ARE APPLICABLE TO ANYONE WHO ACCESSES OR USES THE HOSTED SERVICE. BY ACCESSING OR USING THE HOSTED SERVICE, OR AUTHORIZING OTHERS TO DO SO, YOU, ON BEHALF OF YOURSELF AND THE ENTITY FOR WHOM YOU ARE DOING SO (HEREINAFTER REFERRED TO INTERCHANGEABLY AS "YOU" AND "END USER"), AGREE TO THE TERMS OF USE. IF YOU ARE ACCEPTING THE TERMS OF USE ON BEHALF A COMPANY OR OTHER LEGAL ENTITY, YOU REPRESENT THAT YOU HAVE THE AUTHORITY TO BIND SUCH ENTITY TO THESE TERMS OF USE. IF YOU DO NOT HAVE SUCH AUTHORITY, OR IF

YOU DO NOT WISH TO ACCEPT THESE TERMS OF USE, YOU MUST NOT ACCESS OR USE THE HOSTED SERVICE OR AUTHORIZE ANYONE TO ACCESS OR USE THE HOSTED SERVICE.

## Licenses

THE SOFTWARE LICENSE TERMS AVAILABLE ON THE AVAYA WEBSITE, [HTTPS://SUPPORT.AVAYA.COM/LICENSEINFO](https://support.avaya.com/licenseinfo), UNDER THE LINK "AVAYA SOFTWARE LICENSE TERMS (Avaya Products)" OR SUCH SUCCESSOR SITE AS DESIGNATED BY AVAYA, ARE APPLICABLE TO ANYONE WHO DOWNLOADS, USES AND/OR INSTALLS AVAYA SOFTWARE, PURCHASED FROM AVAYA INC., ANY AVAYA AFFILIATE, OR AN AVAYA CHANNEL PARTNER (AS APPLICABLE) UNDER A COMMERCIAL AGREEMENT WITH AVAYA OR AN AVAYA CHANNEL PARTNER. UNLESS OTHERWISE AGREED TO BY AVAYA IN WRITING, AVAYA DOES NOT EXTEND THIS LICENSE IF THE SOFTWARE WAS OBTAINED FROM ANYONE OTHER THAN AVAYA, AN AVAYA AFFILIATE OR AN AVAYA CHANNEL PARTNER; AVAYA RESERVES THE RIGHT TO TAKE LEGAL ACTION AGAINST YOU AND ANYONE ELSE USING OR SELLING THE SOFTWARE WITHOUT A LICENSE. BY INSTALLING, DOWNLOADING OR USING THE SOFTWARE, OR AUTHORIZING OTHERS TO DO SO, YOU, ON BEHALF OF YOURSELF AND THE ENTITY FOR WHOM YOU ARE INSTALLING, DOWNLOADING OR USING THE SOFTWARE (HEREINAFTER REFERRED TO INTERCHANGEABLY AS "YOU" AND "END USER"), AGREE TO THESE TERMS AND CONDITIONS AND CREATE A BINDING CONTRACT BETWEEN YOU AND AVAYA INC. OR THE APPLICABLE AVAYA AFFILIATE ("AVAYA").

Avaya grants You a license within the scope of the license types described below, with the exception of Heritage Nortel Software, for which the scope of the license is detailed below. Where the order documentation does not expressly identify a license type, the applicable license will be a Designated System License as set forth below in the Designated System(s) License (DS) section as applicable. The applicable number of licenses and units of capacity for which the license is granted will be one (1), unless a different number of licenses or units of capacity is specified in the documentation or other materials available to You. "Software" means computer programs in object code, provided by Avaya or an Avaya Channel Partner, whether as stand-alone products, pre-installed on hardware products, and any upgrades, updates, patches, bug fixes, or modified versions thereto. "Designated Processor" means a single stand-alone computing device. "Server" means a set of Designated Processors that hosts (physically or virtually) a software application to be accessed by multiple users. "Instance" means a single copy of the Software executing at a particular time: (i) on one physical machine; or (ii) on one deployed software virtual machine ("VM") or similar deployment.

## License type(s)

Designated System(s) License (DS). End User may install and use each copy or an Instance of the Software only: 1) on a number of Designated Processors up to the number indicated in the order; or 2) up to the number of Instances of the Software as indicated in the order, Documentation, or as authorized by Avaya in writing. Avaya may require the Designated Processor(s) to be identified in the order by type, serial number, feature key, Instance, location or other specific designation, or to be provided by End User to Avaya through electronic means established by Avaya specifically for this purpose.

Concurrent User License (CU). End User may install and use the Software on multiple Designated Processors or one or more Servers, so long as only the licensed number of Units are accessing and using the Software at any given time as indicated in the order, Documentation, or as authorized by Avaya in writing. A "Unit" means the unit on which Avaya, at its sole discretion, bases the pricing of its licenses and can be, without limitation, an agent, port or user, an e-mail or voice mail account in the name of a person or corporate function (e.g., webmaster or helpdesk), or a directory entry in the administrative database utilized by the Software that permits one user to interface with the Software. Units may be linked to a specific, identified Server or an Instance of the Software.

Cluster License (CL). End User may install and use each copy or an Instance of the Software only up to the number of Clusters as indicated on the order, Documentation, or as authorized by Avaya in writing with a default of one (1) Cluster if not stated.

Enterprise License (EN). End User may install and use each copy or an Instance of the Software only for enterprise-wide use of an unlimited number of Instances of the Software as indicated on the order, Documentation, or as authorized by Avaya in writing.

Named User License (NU). End User may: (i) install and use each copy or Instance of the Software on a single Designated Processor or Server per authorized Named User (defined below); or (ii) install and use each copy or Instance of the Software on a Server so long as only authorized Named Users access and use the Software as indicated in the order, Documentation, or as authorized by Avaya in writing. "Named User", means a user or device that has been expressly authorized by Avaya to access and use the Software. At Avaya's sole discretion, a "Named User" may be, without limitation, designated by name, corporate function (e.g., webmaster or helpdesk), an e-mail or voice mail account in the name of a person or corporate function, or a directory entry in the administrative database utilized by the Software that permits one user to interface with the Software.

Shrinkwrap License (SR). End User may install and use the Software in accordance with the terms and conditions of the applicable license agreements, such as "shrinkwrap" or "clickthrough" license accompanying or applicable to the Software ("Shrinkwrap License") as indicated in the order, Documentation, or as authorized by Avaya in writing.

Transaction License (TR). End User may use the Software up to the number of Transactions as specified during a specified time period and as indicated in the order, Documentation, or as authorized by Avaya in writing. A "Transaction" means the unit by which Avaya, at its sole discretion, bases the pricing of its licensing and can be, without limitation, measured by the usage, access, interaction (between client/server or customer/organization), or operation of the Software within a specified time period (e.g. per hour, per day, per month). Some examples of Transactions include but are not limited to each greeting played/message waiting enabled, each personalized promotion (in any channel), each callback operation, each live agent or web chat session, each call routed or redirected (in any channel). End User may not exceed the number of Transactions without Avaya's prior consent and payment of an additional fee.

#### **Heritage Nortel Software**

"Heritage Nortel Software" means the software that was acquired by Avaya as part of its purchase of the Nortel Enterprise Solutions Business in December 2009. The Heritage Nortel Software is the software contained within the list of Heritage Nortel Products located at <https://support.avaya.com/LicenseInfo> under the link "Heritage Nortel Products" or such successor site as designated by Avaya. For Heritage Nortel Software, Avaya grants Customer a license to use Heritage Nortel Software provided hereunder solely to the extent of the authorized activation or authorized usage level, solely for the purpose specified in the Documentation, and solely as embedded in, for execution on, or for communication with Avaya equipment. Charges for Heritage Nortel Software may be based on extent of activation or use authorized as specified in an order or invoice.

#### **Copyright**

Except where expressly stated otherwise, no use should be made of materials on this site, the Documentation, Software, Hosted Service, or hardware provided by Avaya. All content on this site, the documentation, Hosted Service, and the product provided by Avaya including the selection, arrangement and design of the content is owned either by Avaya or its licensors and is protected by copyright and other intellectual property laws including the sui generis rights relating to the protection of databases. You may not modify, copy, reproduce, republish, upload, post, transmit or distribute in any way any content, in whole or in part, including any code and software unless expressly authorized by Avaya. Unauthorized reproduction, transmission, dissemination, storage, and or use without the express written consent of Avaya can be a criminal, as well as a civil offense under the applicable law.

#### **Virtualization**

The following applies if the product is deployed on a virtual machine. Each product has its own ordering code and license types. Unless otherwise stated, each Instance of a product must be separately licensed and ordered. For example, if the end user customer or Avaya Channel Partner would like to install two Instances of the

same type of products, then two products of that type must be ordered.

#### **Third Party Components**

"Third Party Components" mean certain software programs or portions thereof included in the Software or Hosted Service may contain software (including open source software) distributed under third party agreements ("Third Party Components"), which contain terms regarding the rights to use certain portions of the Software ("Third Party Terms"). As required, information regarding distributed Linux OS source code (for those products that have distributed Linux OS source code) and identifying the copyright holders of the Third Party Components and the Third Party Terms that apply is available in the products, Documentation or on Avaya's website at: <https://support.avaya.com/Copyright> or such successor site as designated by Avaya. The open source software license terms provided as Third Party Terms are consistent with the license rights granted in these Software License Terms, and may contain additional rights benefiting You, such as modification and distribution of the open source software. The Third Party Terms shall take precedence over these Software License Terms, solely with respect to the applicable Third Party Components to the extent that these Software License Terms impose greater restrictions on You than the applicable Third Party Terms.

The following applies only if the H.264 (AVC) codec is distributed with the product. THIS PRODUCT IS LICENSED UNDER THE AVC PATENT PORTFOLIO LICENSE FOR THE PERSONAL USE OF A CONSUMER OR OTHER USES IN WHICH IT DOES NOT RECEIVE REMUNERATION TO (i) ENCODE VIDEO IN COMPLIANCE WITH THE AVC STANDARD ("AVC VIDEO") AND/OR (ii) DECODE AVC VIDEO THAT WAS ENCODED BY A CONSUMER ENGAGED IN A PERSONAL ACTIVITY AND/OR WAS OBTAINED FROM A VIDEO PROVIDER LICENSED TO PROVIDE AVC VIDEO. NO LICENSE IS GRANTED OR SHALL BE IMPLIED FOR ANY OTHER USE. ADDITIONAL INFORMATION MAY BE OBTAINED FROM MPEG LA, L.L.C. SEE [HTTP://WWW.MPEGLA.COM](http://www.mpegla.com).

#### **Service Provider**

THE FOLLOWING APPLIES TO AVAYA CHANNEL PARTNER'S HOSTING OF AVAYA PRODUCTS OR SERVICES. THE PRODUCT OR HOSTED SERVICE MAY USE THIRD PARTY COMPONENTS SUBJECT TO THIRD PARTY TERMS AND REQUIRE A SERVICE PROVIDER TO BE INDEPENDENTLY LICENSED DIRECTLY FROM THE THIRD PARTY SUPPLIER. AN AVAYA CHANNEL PARTNER'S HOSTING OF AVAYA PRODUCTS MUST BE AUTHORIZED IN WRITING BY AVAYA AND IF THOSE HOSTED PRODUCTS USE OR EMBED CERTAIN THIRD PARTY SOFTWARE, INCLUDING BUT NOT LIMITED TO MICROSOFT SOFTWARE OR CODECS, THE AVAYA CHANNEL PARTNER IS REQUIRED TO INDEPENDENTLY OBTAIN ANY APPLICABLE LICENSE AGREEMENTS, AT THE AVAYA CHANNEL PARTNER'S EXPENSE, DIRECTLY FROM THE APPLICABLE THIRD PARTY SUPPLIER.

WITH RESPECT TO CODECS, IF THE AVAYA CHANNEL PARTNER IS HOSTING ANY PRODUCTS THAT USE OR EMBED THE H.264 CODEC OR H.265 CODEC, THE AVAYA CHANNEL PARTNER ACKNOWLEDGES AND AGREES THE AVAYA CHANNEL PARTNER IS RESPONSIBLE FOR ANY AND ALL RELATED FEES AND/OR ROYALTIES. THE H.264 (AVC) CODEC IS LICENSED UNDER THE AVC PATENT PORTFOLIO LICENSE FOR THE PERSONAL USE OF A CONSUMER OR OTHER USES IN WHICH IT DOES NOT RECEIVE REMUNERATION TO: (I) ENCODE VIDEO IN COMPLIANCE WITH THE AVC STANDARD ("AVC VIDEO") AND/OR (II) DECODE AVC VIDEO THAT WAS ENCODED BY A CONSUMER ENGAGED IN A PERSONAL ACTIVITY AND/OR WAS OBTAINED FROM A VIDEO PROVIDER LICENSED TO PROVIDE AVC VIDEO. NO LICENSE IS GRANTED OR SHALL BE IMPLIED FOR ANY OTHER USE. ADDITIONAL INFORMATION FOR H.264 (AVC) AND H.265 (HEVC) CODECS MAY BE OBTAINED FROM MPEG LA, L.L.C. SEE [HTTP://WWW.MPEGLA.COM](http://www.mpegla.com).

#### **Compliance with Laws**

You acknowledge and agree that it is Your responsibility for complying with any applicable laws and regulations, including, but not limited to laws and regulations related to call recording, data privacy, intellectual property, trade secret, fraud, and music performance rights, in the country or territory where the Avaya product is used.

## Preventing Toll Fraud

"Toll Fraud" is the unauthorized use of your telecommunications system by an unauthorized party (for example, a person who is not a corporate employee, agent, subcontractor, or is not working on your company's behalf). Be aware that there can be a risk of Toll Fraud associated with your system and that, if Toll Fraud occurs, it can result in substantial additional charges for your telecommunications services.

### Avaya Toll Fraud intervention

If You suspect that You are being victimized by Toll Fraud and You need technical assistance or support, call Technical Service Center Toll Fraud Intervention Hotline at +1-800-643-2353 for the United States and Canada. For additional support telephone numbers, see the Avaya Support website: <https://support.avaya.com> or such successor site as designated by Avaya.

### Security Vulnerabilities

Information about Avaya's security support policies can be found in the Security Policies and Support section of <https://support.avaya.com/security>.

Suspected Avaya product security vulnerabilities are handled per the Avaya Product Security Support Flow (<https://support.avaya.com/css/P8/documents/100161515>).

### Downloading Documentation

For the most current versions of Documentation, see the Avaya Support website: <https://support.avaya.com>, or such successor site as designated by Avaya.

### Contact Avaya Support

See the Avaya Support website: <https://support.avaya.com> for product or Hosted Service notices and articles, or to report a problem with your Avaya product or Hosted Service. For a list of support telephone numbers and contact addresses, go to the Avaya Support website: <https://support.avaya.com> (or such successor site as designated by Avaya), scroll to the bottom of the page, and select Contact Avaya Support.

### Trademarks

The trademarks, logos and service marks ("Marks") displayed in this site, the Documentation, Hosted Service(s), and product(s) provided by Avaya are the registered or unregistered Marks of Avaya, its affiliates, its licensors, its suppliers, or other third parties. Users are not permitted to use such Marks without prior written consent from Avaya or such third party which may own the Mark. Nothing contained in this site, the Documentation, Hosted Service(s) and product(s) should be construed as granting, by implication, estoppel, or otherwise, any license or right in and to the Marks without the express written permission of Avaya or the applicable third party.

Avaya is a registered trademark of Avaya Inc.

All non-Avaya trademarks are the property of their respective owners. Linux® is the registered trademark of Linus Torvalds in the U.S. and other countries.

### Related links

[Notices](#) on page 4

© 2021, Avaya Inc.  
All Rights Reserved.

---

# Notices

## Notice

While reasonable efforts have been made to ensure that the information in this document is complete and accurate at the time of printing, Avaya assumes no liability for any errors. Avaya reserves the right to make changes and corrections to the information in this document without the obligation to notify any person or organization of such changes.

## Documentation disclaimer

"Documentation" means information published in varying mediums which may include product information, operating instructions and performance specifications that are generally made available to users of products. Documentation does not include marketing materials. Avaya shall not be responsible for any modifications, additions, or deletions to the original published version of Documentation unless such modifications, additions, or deletions were performed by or on the express behalf of Avaya. End User agrees to indemnify and hold harmless Avaya, Avaya's agents, servants and employees against all claims, lawsuits, demands and judgments arising out of, or in connection with, subsequent modifications, additions or deletions to this documentation, to the extent made by End User.

## Link disclaimer

Avaya is not responsible for the contents or reliability of any linked websites referenced within this site or Documentation provided by Avaya. Avaya is not responsible for the accuracy of any information, statement or content provided on these sites and does not necessarily endorse the products, services, or information described or offered within them. Avaya does not guarantee that these links will work all the time and has no control over the availability of the linked pages.

## Warranty

Avaya provides a limited warranty on Avaya hardware and software. Refer to your sales agreement to establish the terms of the limited warranty. In addition, Avaya's standard warranty language, as well as information regarding support for this product while under warranty is available to Avaya customers and other parties through the Avaya Support website: <https://support.avaya.com/helpcenter/getGenericDetails?detailId=C20091120112456651010> under the link "Warranty & Product Lifecycle" or such successor site as designated by Avaya. Please note that if You acquired the product(s) from an authorized Avaya Channel Partner outside of the United States and Canada, the warranty is provided to You by said Avaya Channel Partner and not by Avaya.

"Hosted Service" means an Avaya hosted service subscription that You acquire from either Avaya or an authorized Avaya Channel Partner (as applicable) and which is described further in Hosted SAS or other service description documentation regarding the applicable hosted service. If You purchase a Hosted Service subscription, the foregoing limited warranty may not apply but You may be entitled to support services in connection with the Hosted Service as described further in your service description documents for the applicable Hosted Service. Contact Avaya or Avaya Channel Partner (as applicable) for more information.

## Hosted Service

THE FOLLOWING APPLIES ONLY IF YOU PURCHASE AN AVAYA HOSTED SERVICE SUBSCRIPTION FROM AVAYA OR AN AVAYA CHANNEL PARTNER (AS APPLICABLE), THE TERMS OF USE FOR HOSTED SERVICES ARE AVAILABLE ON THE AVAYA WEBSITE, [HTTPS://SUPPORT.AVAYA.COM/LICENSEINFO](https://support.avaya.com/licenseinfo) UNDER THE LINK "Avaya Terms of Use for Hosted Services" OR SUCH SUCCESSOR SITE AS DESIGNATED BY AVAYA, AND ARE APPLICABLE TO ANYONE WHO ACCESSES OR USES THE HOSTED SERVICE. BY ACCESSING OR USING THE HOSTED SERVICE, OR AUTHORIZING OTHERS TO DO SO, YOU, ON BEHALF OF YOURSELF AND THE ENTITY FOR WHOM YOU ARE DOING SO (HEREINAFTER REFERRED TO INTERCHANGEABLY AS "YOU" AND "END USER"), AGREE TO THE TERMS OF USE. IF YOU ARE ACCEPTING THE TERMS OF USE ON BEHALF A COMPANY OR OTHER LEGAL ENTITY, YOU REPRESENT THAT YOU HAVE THE AUTHORITY TO BIND SUCH ENTITY TO THESE TERMS OF USE. IF YOU DO NOT HAVE SUCH AUTHORITY, OR IF YOU DO NOT WISH TO ACCEPT THESE TERMS OF USE, YOU MUST NOT ACCESS OR USE THE HOSTED SERVICE OR AUTHORIZE ANYONE TO ACCESS OR USE THE HOSTED SERVICE.

## Licenses

THE SOFTWARE LICENSE TERMS AVAILABLE ON THE AVAYA WEBSITE, [HTTPS://SUPPORT.AVAYA.COM/LICENSEINFO](https://support.avaya.com/licenseinfo), UNDER THE LINK "AVAYA SOFTWARE LICENSE TERMS (Avaya Products)" OR SUCH SUCCESSOR SITE AS DESIGNATED BY AVAYA, ARE APPLICABLE TO ANYONE WHO DOWNLOADS,

USES AND/OR INSTALLS AVAYA SOFTWARE, PURCHASED FROM AVAYA INC., ANY AVAYA AFFILIATE, OR AN AVAYA CHANNEL PARTNER (AS APPLICABLE) UNDER A COMMERCIAL AGREEMENT WITH AVAYA OR AN AVAYA CHANNEL PARTNER. UNLESS OTHERWISE AGREED TO BY AVAYA IN WRITING, AVAYA DOES NOT EXTEND THIS LICENSE IF THE SOFTWARE WAS OBTAINED FROM ANYONE OTHER THAN AVAYA, AN AVAYA AFFILIATE OR AN AVAYA CHANNEL PARTNER; AVAYA RESERVES THE RIGHT TO TAKE LEGAL ACTION AGAINST YOU AND ANYONE ELSE USING OR SELLING THE SOFTWARE WITHOUT A LICENSE. BY INSTALLING, DOWNLOADING OR USING THE SOFTWARE, OR AUTHORIZING OTHERS TO DO SO, YOU, ON BEHALF OF YOURSELF AND THE ENTITY FOR WHOM YOU ARE INSTALLING, DOWNLOADING OR USING THE SOFTWARE (HEREINAFTER REFERRED TO INTERCHANGEABLY AS "YOU" AND "END USER"), AGREE TO THESE TERMS AND CONDITIONS AND CREATE A BINDING CONTRACT BETWEEN YOU AND AVAYA INC. OR THE APPLICABLE AVAYA AFFILIATE ("AVAYA").

Avaya grants You a license within the scope of the license types described below, with the exception of Heritage Nortel Software, for which the scope of the license is detailed below. Where the order documentation does not expressly identify a license type, the applicable license will be a Designated System License as set forth below in the Designated System(s) License (DS) section as applicable. The applicable number of licenses and units of capacity for which the license is granted will be one (1), unless a different number of licenses or units of capacity is specified in the documentation or other materials available to You. "Software" means computer programs in object code, provided by Avaya or an Avaya Channel Partner, whether as stand-alone products, pre-installed on hardware products, and any upgrades, updates, patches, bug fixes, or modified versions thereto. "Designated Processor" means a single stand-alone computing device. "Server" means a set of Designated Processors that hosts (physically or virtually) a software application to be accessed by multiple users. "Instance" means a single copy of the Software executing at a particular time: (i) on one physical machine; or (ii) on one deployed software virtual machine ("VM") or similar deployment.

#### **License type(s)**

**Designated System(s) License (DS).** End User may install and use each copy or an Instance of the Software only: 1) on a number of Designated Processors up to the number indicated in the order; or 2) up to the number of Instances of the Software as indicated in the order, Documentation, or as authorized by Avaya in writing. Avaya may require the Designated Processor(s) to be identified in the order by type, serial number, feature key, Instance, location or other specific designation, or to be provided by End User to Avaya through electronic means established by Avaya specifically for this purpose.

**Concurrent User License (CU).** End User may install and use the Software on multiple Designated Processors or one or more Servers, so long as only the licensed number of Units are accessing and using the Software at any given time as indicated in the order, Documentation, or as authorized by Avaya in writing. A "Unit" means the unit on which Avaya, at its sole discretion, bases the pricing of its licenses and can be, without limitation, an agent, port or user, an e-mail or voice mail account in the name of a person or corporate function (e.g., webmaster or helpdesk), or a directory entry in the administrative database utilized by the Software that permits one user to interface with the Software. Units may be linked to a specific, identified Server or an Instance of the Software.

**Cluster License (CL).** End User may install and use each copy or an Instance of the Software only up to the number of Clusters as indicated on the order, Documentation, or as authorized by Avaya in writing with a default of one (1) Cluster if not stated.

**Enterprise License (EN).** End User may install and use each copy or an Instance of the Software only for enterprise-wide use of an unlimited number of Instances of the Software as indicated on the order, Documentation, or as authorized by Avaya in writing.

**Named User License (NU).** End User may: (i) install and use each copy or Instance of the Software on a single Designated Processor or Server per authorized Named User (defined below); or (ii) install and use each copy or Instance of the Software on a Server so long as only authorized Named Users access and use the Software as indicated in the order, Documentation, or as authorized by Avaya in

writing. "Named User", means a user or device that has been expressly authorized by Avaya to access and use the Software. At Avaya's sole discretion, a "Named User" may be, without limitation, designated by name, corporate function (e.g., webmaster or helpdesk), an e-mail or voice mail account in the name of a person or corporate function, or a directory entry in the administrative database utilized by the Software that permits one user to interface with the Software.

**Shrinkwrap License (SR).** End User may install and use the Software in accordance with the terms and conditions of the applicable license agreements, such as "shrinkwrap" or "clickthrough" license accompanying or applicable to the Software ("Shrinkwrap License") as indicated in the order, Documentation, or as authorized by Avaya in writing.

**Transaction License (TR).** End User may use the Software up to the number of Transactions as specified during a specified time period and as indicated in the order, Documentation, or as authorized by Avaya in writing. A "Transaction" means the unit by which Avaya, at its sole discretion, bases the pricing of its licensing and can be, without limitation, measured by the usage, access, interaction (between client/server or customer/organization), or operation of the Software within a specified time period (e.g. per hour, per day, per month). Some examples of Transactions include but are not limited to each greeting played/message waiting enabled, each personalized promotion (in any channel), each callback operation, each live agent or web chat session, each call routed or redirected (in any channel). End User may not exceed the number of Transactions without Avaya's prior consent and payment of an additional fee.

#### **Heritage Nortel Software**

"Heritage Nortel Software" means the software that was acquired by Avaya as part of its purchase of the Nortel Enterprise Solutions Business in December 2009. The Heritage Nortel Software is the software contained within the list of Heritage Nortel Products located at <https://support.avaya.com/LicenseInfo> under the link "Heritage Nortel Products" or such successor site as designated by Avaya. For Heritage Nortel Software, Avaya grants Customer a license to use Heritage Nortel Software provided hereunder solely to the extent of the authorized activation or authorized usage level, solely for the purpose specified in the Documentation, and solely as embedded in, for execution on, or for communication with Avaya equipment. Charges for Heritage Nortel Software may be based on extent of activation or use authorized as specified in an order or invoice.

#### **Copyright**

Except where expressly stated otherwise, no use should be made of materials on this site, the Documentation, Software, Hosted Service, or hardware provided by Avaya. All content on this site, the documentation, Hosted Service, and the product provided by Avaya including the selection, arrangement and design of the content is owned either by Avaya or its licensors and is protected by copyright and other intellectual property laws including the sui generis rights relating to the protection of databases. You may not modify, copy, reproduce, republish, upload, post, transmit or distribute in any way any content, in whole or in part, including any code and software unless expressly authorized by Avaya. Unauthorized reproduction, transmission, dissemination, storage, and or use without the express written consent of Avaya can be a criminal, as well as a civil offense under the applicable law.

#### **Virtualization**

The following applies if the product is deployed on a virtual machine. Each product has its own ordering code and license types. Unless otherwise stated, each Instance of a product must be separately licensed and ordered. For example, if the end user customer or Avaya Channel Partner would like to install two Instances of the same type of products, then two products of that type must be ordered.

#### **Third Party Components**

"Third Party Components" mean certain software programs or portions thereof included in the Software or Hosted Service may contain software (including open source software) distributed under third party agreements ("Third Party Components"), which contain terms regarding the rights to use certain portions of the Software ("Third Party Terms"). As required, information regarding distributed Linux OS source code (for those products that have distributed Linux

OS source code) and identifying the copyright holders of the Third Party Components and the Third Party Terms that apply is available in the products, Documentation or on Avaya's website at: <https://support.avaya.com/Copyright> or such successor site as designated by Avaya. The open source software license terms provided as Third Party Terms are consistent with the license rights granted in these Software License Terms, and may contain additional rights benefiting You, such as modification and distribution of the open source software. The Third Party Terms shall take precedence over these Software License Terms, solely with respect to the applicable Third Party Components to the extent that these Software License Terms impose greater restrictions on You than the applicable Third Party Terms.

The following applies only if the H.264 (AVC) codec is distributed with the product. THIS PRODUCT IS LICENSED UNDER THE AVC PATENT PORTFOLIO LICENSE FOR THE PERSONAL USE OF A CONSUMER OR OTHER USES IN WHICH IT DOES NOT RECEIVE REMUNERATION TO (i) ENCODE VIDEO IN COMPLIANCE WITH THE AVC STANDARD ("AVC VIDEO") AND/OR (ii) DECODE AVC VIDEO THAT WAS ENCODED BY A CONSUMER ENGAGED IN A PERSONAL ACTIVITY AND/OR WAS OBTAINED FROM A VIDEO PROVIDER LICENSED TO PROVIDE AVC VIDEO. NO LICENSE IS GRANTED OR SHALL BE IMPLIED FOR ANY OTHER USE. ADDITIONAL INFORMATION MAY BE OBTAINED FROM MPEG LA, L.L.C. SEE [HTTP://WWW.MPEGLA.COM](http://www.mpegla.com).

#### **Service Provider**

THE FOLLOWING APPLIES TO AVAYA CHANNEL PARTNER'S HOSTING OF AVAYA PRODUCTS OR SERVICES. THE PRODUCT OR HOSTED SERVICE MAY USE THIRD PARTY COMPONENTS SUBJECT TO THIRD PARTY TERMS AND REQUIRE A SERVICE PROVIDER TO BE INDEPENDENTLY LICENSED DIRECTLY FROM THE THIRD PARTY SUPPLIER. AN AVAYA CHANNEL PARTNER'S HOSTING OF AVAYA PRODUCTS MUST BE AUTHORIZED IN WRITING BY AVAYA AND IF THOSE HOSTED PRODUCTS USE OR EMBED CERTAIN THIRD PARTY SOFTWARE, INCLUDING BUT NOT LIMITED TO MICROSOFT SOFTWARE OR CODECS, THE AVAYA CHANNEL PARTNER IS REQUIRED TO INDEPENDENTLY OBTAIN ANY APPLICABLE LICENSE AGREEMENTS, AT THE AVAYA CHANNEL PARTNER'S EXPENSE, DIRECTLY FROM THE APPLICABLE THIRD PARTY SUPPLIER.

WITH RESPECT TO CODECS, IF THE AVAYA CHANNEL PARTNER IS HOSTING ANY PRODUCTS THAT USE OR EMBED THE H.264 CODEC OR H.265 CODEC, THE AVAYA CHANNEL PARTNER ACKNOWLEDGES AND AGREES THE AVAYA CHANNEL PARTNER IS RESPONSIBLE FOR ANY AND ALL RELATED FEES AND/OR ROYALTIES. THE H.264 (AVC) CODEC IS LICENSED UNDER THE AVC PATENT PORTFOLIO LICENSE FOR THE PERSONAL USE OF A CONSUMER OR OTHER USES IN WHICH IT DOES NOT RECEIVE REMUNERATION TO: (I) ENCODE VIDEO IN COMPLIANCE WITH THE AVC STANDARD ("AVC VIDEO") AND/OR (II) DECODE AVC VIDEO THAT WAS ENCODED BY A CONSUMER ENGAGED IN A PERSONAL ACTIVITY AND/OR WAS OBTAINED FROM A VIDEO PROVIDER LICENSED TO PROVIDE AVC VIDEO. NO LICENSE IS GRANTED OR SHALL BE IMPLIED FOR ANY OTHER USE. ADDITIONAL INFORMATION FOR H.264 (AVC) AND H.265 (HEVC) CODECS MAY BE OBTAINED FROM MPEG LA, L.L.C. SEE [HTTP://WWW.MPEGLA.COM](http://www.mpegla.com).

#### **Compliance with Laws**

You acknowledge and agree that it is Your responsibility for complying with any applicable laws and regulations, including, but not limited to laws and regulations related to call recording, data privacy, intellectual property, trade secret, fraud, and music performance rights, in the country or territory where the Avaya product is used.

#### **Preventing Toll Fraud**

"Toll Fraud" is the unauthorized use of your telecommunications system by an unauthorized party (for example, a person who is not a corporate employee, agent, subcontractor, or is not working on your company's behalf). Be aware that there can be a risk of Toll Fraud associated with your system and that, if Toll Fraud occurs, it can result in substantial additional charges for your telecommunications services.

#### **Avaya Toll Fraud intervention**

If You suspect that You are being victimized by Toll Fraud and You need technical assistance or support, call Technical Service Center Toll Fraud Intervention Hotline at +1-800-643-2353 for the United States and Canada. For additional support telephone numbers, see the Avaya Support website: <https://support.avaya.com> or such successor site as designated by Avaya.

#### **Security Vulnerabilities**

Information about Avaya's security support policies can be found in the Security Policies and Support section of <https://support.avaya.com/security>.

Suspected Avaya product security vulnerabilities are handled per the Avaya Product Security Support Flow (<https://support.avaya.com/css/P8/documents/100161515>).

#### **Downloading Documentation**

For the most current versions of Documentation, see the Avaya Support website: <https://support.avaya.com>, or such successor site as designated by Avaya.

#### **Contact Avaya Support**

See the Avaya Support website: <https://support.avaya.com> for product or Hosted Service notices and articles, or to report a problem with your Avaya product or Hosted Service. For a list of support telephone numbers and contact addresses, go to the Avaya Support website: <https://support.avaya.com> (or such successor site as designated by Avaya), scroll to the bottom of the page, and select Contact Avaya Support.

#### **Trademarks**

The trademarks, logos and service marks ("Marks") displayed in this site, the Documentation, Hosted Service(s), and product(s) provided by Avaya are the registered or unregistered Marks of Avaya, its affiliates, its licensors, its suppliers, or other third parties. Users are not permitted to use such Marks without prior written consent from Avaya or such third party which may own the Mark. Nothing contained in this site, the Documentation, Hosted Service(s) and product(s) should be construed as granting, by implication, estoppel, or otherwise, any license or right in and to the Marks without the express written permission of Avaya or the applicable third party.

Avaya is a registered trademark of Avaya Inc.

All non-Avaya trademarks are the property of their respective owners. Linux<sup>®</sup> is the registered trademark of Linus Torvalds in the U.S. and other countries.

# Contents

<b>Part 1: Introduction</b> .....	27
<b>Chapter 1: Introduction</b> .....	28
Purpose.....	28
New in Release 11.1.....	28
New in Release 11.1.SP1.....	30
New in Release 11.1.FP1.....	31
<b>Chapter 2: Overview</b> .....	33
Manager Modes.....	33
Security Configuration Mode.....	34
Standard Mode Configuration Mode.....	35
Server Edition Configuration Mode.....	37
Shell Server Mode.....	38
Backward Compatibility.....	39
<b>Chapter 3: Getting Started</b> .....	40
PC requirements.....	40
Installing Manager.....	41
Downloading Manager AdminLite.....	42
Starting Manager.....	43
Opening a Configuration.....	44
Login messages.....	45
Changing the Manager Language.....	47
<b>Chapter 4: Menu Bar Commands</b> .....	49
File Menu.....	49
File > Open Configuration.....	50
File > Close Configuration.....	50
File > Save Configuration.....	50
File > Save Configuration As.....	52
File > Change Working Directory.....	52
File > Preferences.....	53
File > Offline.....	62
File > Advanced.....	63
File > Backup/Restore.....	80
File > Import/Export.....	80
File > Exit.....	81
View Menu.....	81
Tools Menu.....	82
Tools > Extension Renumber.....	82
Tools > Line Renumber.....	82
Tools > Connect To.....	83

Tools > Export > User.....	83
Tools > SCN Service User Management.....	84
Tools > Busy on Held Validation.....	84
Tools > MSN Configuration.....	85
Tools > Print Button Labels.....	85
Tools > Import Templates.....	86
File > Advanced > Generate WebLM ID.....	86
Tools > License Migration.....	87
Security Mode Menus.....	88
Embedded File Management Menus.....	89
<b>Chapter 5: Manager User Interface.....</b>	<b>92</b>
Title Bar.....	92
Toolbars.....	92
The Main Toolbar.....	93
The Navigation Toolbar.....	94
The Details Toolbar.....	94
The Navigation Pane.....	94
Expanding and Collapsing the Navigation Tree.....	95
The Group Pane.....	95
Sorting the List.....	95
Customizing the Columns Displayed.....	96
Changing the Column Widths.....	96
Adding a New Record.....	96
Deleting an Record.....	97
Validating an Record.....	97
Show in Groups.....	97
The Details Pane.....	97
Managing Records.....	98
The Error Pane.....	99
Altering the Automatic Validation Settings.....	100
Revalidating Configuration Settings.....	100
Viewing an Error or Warning.....	100
The Status Bar.....	101
Configuring the Interface.....	101
Resizing the Manager Window.....	102
Moving the Border Between the Panes.....	102
Showing or Hiding Toolbars.....	102
Moving Toolbars.....	103
Showing or Hiding Panes.....	103
Changing the Position of the Details Pane.....	103
Changing the Size of Configuration Icons.....	104
Changing Tab Display.....	104
<b>Chapter 6: Working with the Server Edition Manager User Interface.....</b>	<b>105</b>



- Server Edition Solution View..... 105
- System Inventories..... 108
- Default Settings..... 108
- Record Consolidation..... 109
- Telephone Features Supported Across Server Edition and SCN Networks..... 110
- Part 2: Security Configuration..... 112**
- Chapter 7: Security Administration..... 113**
- Service Users, Application Roles, and Rights Groups..... 113
- Default Service Users and Rights Groups..... 115
- Default Service Users and Rights Groups for IP Office R 11.0 and earlier..... 122
- Access Control..... 127
- Encryption..... 128
- Message Authentication..... 129
- Certificates..... 130
- Implementing Security..... 131
- SRTP..... 133
- Chapter 8: Editing IP Office Security Settings in Manager..... 135**
- Loading Security Settings..... 135
- Saving Security Settings..... 136
- Resetting a System's Security Settings..... 136
- Chapter 9: Security Mode Field Descriptions..... 138**
- General Security Settings..... 139
- General..... 139
- System..... 145
- System Details..... 145
- Unsecured Interfaces..... 147
- Certificates..... 148
- Security Services Settings..... 154
- Rights Groups..... 156
- Group Details..... 156
- Configuration..... 156
- Security Administration..... 158
- System Status..... 158
- Telephony APIs..... 159
- HTTP..... 159
- Web Services..... 159
- External..... 161
- Service Users..... 162
- Part 3: System Configuration..... 164**
- Chapter 10: Editing Configuration Settings..... 165**
- Mergeable Settings..... 167
- Configuration Size..... 177

Setting the Discovery Addresses.....	178
Known System Discovery.....	180
Configuring Manager for Known System Discovery.....	180
Using Known System Discovery.....	180
Opening a Configuration from a System.....	182
Opening a Configuration Stored on PC.....	184
Creating New Records.....	185
Adding a New Record Using the Details Pane.....	185
Adding a New Record Using the Group Pane.....	185
Adding a New Record Using the Navigation Pane.....	185
Other record creation methods.....	186
Creating an Offline Configuration.....	186
Importing and Exporting Settings.....	188
Exporting Settings.....	190
Importing Settings.....	190
Copying and Pasting.....	191
Saving a Configuration onto PC.....	191
Sending a Configuration.....	192
Erasing the Configuration.....	194
Default Settings.....	194
<b>Chapter 11: Configuration Mode Field Descriptions.....</b>	<b>197</b>
Configuration field display.....	198
Configuration field display in Standard mode.....	198
Configuration field display in Server Edition mode.....	199
BOOTP Record.....	201
Operator.....	203
System .....	203
System.....	204
LAN1.....	211
LAN2.....	225
DNS.....	226
Voicemail.....	226
Telephony.....	233
Directory Services.....	251
System Events.....	256
SMTP.....	263
System   SMDR.....	264
VCM.....	266
Integrated Contact Reporter.....	268
VoIP.....	269
VoIP Security.....	271
Access Control Lists.....	274
Dialer.....	275

- Contact Center..... 277
- Avaya Cloud Services..... 278
- Line..... 279
  - Analog Line..... 280
  - BRI Line..... 289
  - PRI Trunks..... 294
  - S0 Line..... 325
  - H.323 Line..... 328
  - IP DECT Line..... 334
  - SIP Line..... 339
  - SIP DECT Line..... 373
  - SM Line..... 375
  - IP Office Line..... 384
- Control Unit..... 395
- Extension..... 396
  - Extn..... 397
  - Analog..... 400
  - Extension VoIP..... 403
  - Extension T38 Fax..... 410
  - IP DECT Extension..... 412
  - SIP DECT Base Extension..... 413
- User..... 413
  - User..... 414
  - Voicemail..... 421
  - User | DND..... 426
  - Short Codes..... 427
  - Source Numbers..... 428
  - Telephony..... 435
  - User | Forwarding..... 446
  - Dial In..... 449
  - Voice Recording..... 450
  - Button Programming..... 452
  - User | Menu Programming..... 453
  - Mobility..... 454
  - Group Memberships..... 458
  - Announcements..... 458
  - SIP..... 459
  - Personal Directory..... 460
  - Web Self Administration..... 462
- Group..... 464
  - Group..... 465
  - Queuing..... 470
  - Overflow..... 473

Fallback.....	475
Group   Voicemail.....	478
Voice Recording.....	483
Announcements.....	484
SIP.....	487
Short Code.....	488
Service.....	489
Service.....	490
Bandwidth.....	491
IP.....	493
Autoconnect.....	495
Quota.....	495
PPP.....	496
Fallback.....	498
Dial In.....	499
SSL VPN Service.....	499
RAS.....	502
PPP.....	503
Incoming Call Route.....	504
Standard.....	507
Voice Recording.....	511
Destinations.....	512
WAN Port.....	514
WAN Port.....	514
Frame Relay.....	515
DLCIs.....	515
Advanced.....	517
Directory Entry.....	518
Time Profile.....	519
Firewall Profile.....	521
Firewall   Standard.....	521
Firewall   Custom.....	523
Static NAT.....	525
IP Route.....	525
IP Route   IP Route.....	526
RIP Dynamic Routing.....	527
Account Code.....	528
Account Code.....	528
Voice Recording.....	528
Subscription.....	530
License.....	531
License.....	532
Remote Server.....	534

Tunnel.....	537
L2TP Tunnel.....	538
IP Security Tunnel.....	540
Auto Attendant.....	543
Auto Attendant.....	544
Actions.....	546
Authorization Codes.....	548
User Rights.....	549
User.....	549
Short Codes.....	550
Button Programming.....	550
Telephony.....	551
User Rights Membership.....	555
Voicemail.....	556
Forwarding.....	557
ARS.....	558
ARS.....	558
Location.....	562
Address.....	564
<b>Chapter 12: Configure General System Settings.....</b>	<b>567</b>
Applying Licenses.....	567
PLDS licensing.....	567
Web License Manager (WebLM).....	568
Server Edition Centralized Licensing.....	569
Distributing Server Edition Licenses.....	569
Procedures for Applying Licensing.....	574
Converting from Nodal to Centralized Licensing.....	579
Migrating Licenses to PLDS.....	580
Certificate Management.....	581
Certificate Overview.....	582
Certificate Support.....	586
On-boarding.....	595
Configuring an SSL VPN using an on-boarding file.....	595
System Date and Time.....	596
Configuring Time Profiles.....	597
Overriding a Time Profile.....	599
Working with Templates.....	600
Importing Trunk Templates.....	601
Creating a Template in Manager.....	602
Creating a New Record from a Template in Manager.....	602
Creating an Analog Trunk Template in Manager.....	603
Creating a New Analog Trunk from a Template in Manager.....	603
Applying a Template to an Analog Trunk.....	604

Centralized System Directory.....	604
Advice of Charge.....	608
Emergency Call.....	609
Fax Support.....	610
Server Edition T38 Fax Support.....	612
Caller Display.....	613
Parking Calls.....	614
Configuring Call Admission Control.....	615
Manager location tab.....	615
<b>Assigning a network entity to a location</b> .....	616
System actions at maximum call threshold.....	616
Example.....	617
Ring Tones.....	619
Music On Hold.....	620
System Source.....	622
Alternate Source.....	622
Conferencing.....	626
Conference Phones.....	627
Ad-Hoc Conferencing.....	628
Meet Me Conferencing.....	630
Routing External Callers.....	631
Context Sensitive Conferencing.....	632
Paging.....	634
Paging Via Voicemail Pro.....	636
Automatic Intercom Calls.....	638
Wide Band Audio Support.....	639
Media Connection Preservation.....	640
Configuring ARS.....	641
Example ARS Operation.....	643
ARS Operation.....	644
Configuring IP Routes.....	653
Creating a Virtual WAN Port.....	654
System Events.....	655
Configuring Alarm Destinations.....	656
Configuring authorization codes.....	656
Entering an Authorization Code.....	658
Preventing Toll Bypass.....	658
Call Barring.....	659
Applying Call Barring.....	659
Overriding call barring.....	660
<b>Chapter 13: Configure User Settings</b> .....	662
User Management Overview.....	663
Configuring User Rights.....	664

Adding User Rights.....	666
Creating a User Right Based on an Existing User.....	666
Associating User Rights to a User.....	667
Copy User Rights Settings over a User's Settings.....	667
Configuring Gmail Integration.....	668
Call Intrusion.....	669
Call Tagging.....	675
Call Waiting.....	675
Call Restriction.....	676
Centralized Call Log.....	677
Centralized call log field descriptions.....	678
Call scenarios.....	680
Centralized call logging controls.....	681
Centralized Personal Directory.....	683
Account Code Configuration.....	683
Setting a User to Forced Account Code.....	684
Coverage Groups.....	685
DND, Follow Me and Forwarding.....	685
Do Not Disturb (DND).....	687
Follow Me.....	689
Forward Unconditional.....	691
Forward on Busy.....	693
Forward on No Answer.....	695
Determining a User's Busy Status.....	697
Chaining.....	698
Hot Desking.....	699
Remote Hot Desking.....	701
Call Center Agents.....	702
Hot Desking Examples.....	702
Automatic Log Out.....	704
Group Operation.....	705
Group Types.....	708
Call Presentation.....	709
Group Member Availability.....	710
Example Hunt Group.....	712
CBC/CCC Agents and Hunt Groups.....	714
Malicious Call Tracing (MCID).....	715
Message Waiting Indication.....	715
Message Waiting Indication for Analog Phones.....	716
Message Waiting Indication for Analog Trunks.....	717
Mobile Call Control.....	718
Mobile Direct Access (MDA).....	721
Mobile Callback.....	723

Twinning.....	723
Private Calls.....	726
System Phone Features.....	727
The 'No User' User.....	728
Suppressing the NoCallerId alarm.....	729
Transferring Calls.....	729
Off-Switch Transfer Restrictions.....	731
Context Sensitive Transfer.....	732
Dial Tone Transfer.....	732
Handsfree Announced Transfers.....	734
One Touch Transferring.....	736
Centrex Transfer.....	737
Avaya cloud authorization.....	738
Configuring automatic synchronization.....	738
Enabling Avaya cloud account authorization.....	739
Configuring token cache time.....	740
Apple push notification services.....	740
Enabling Apple push notifications.....	741
<b>Part 4: Configuring IP Office.....</b>	<b>743</b>
<b>Chapter 14: Configure Server Edition system settings.....</b>	<b>744</b>
Synchronizing Server Edition passwords in Web Manager.....	744
Shared Administration User Account.....	745
Voicemail Administration.....	745
Server Edition Resiliency.....	746
Voicemail Pro Resiliency.....	748
Avaya one-X <sup>®</sup> Portal resiliency.....	750
Phone Resiliency.....	752
Configuring Resiliency.....	755
Synchronizing the Configurations.....	760
Starting Web Control.....	760
<b>Chapter 15: Configuring SIP Trunks.....</b>	<b>761</b>
Overview.....	761
Configuring a SIP Trunk.....	762
SIP Line Requirements.....	763
SIP Incoming Call Routing.....	765
SIP Prefix Operation.....	766
SIP messaging.....	767
Outgoing call message details.....	768
Incoming call message details.....	772
Codec selection.....	777
DTMF transmission.....	778
Fax over SIP.....	778
Hold scenarios.....	778



SIP REFER.....	780
IP Office SIP trunk specifications.....	781
RFCs.....	783
Transport protocols.....	784
Request methods.....	784
Response methods.....	784
Headers.....	785
<b>Chapter 16: Configuring Small Community Networking.....</b>	<b>786</b>
Supported Small Community Network Network Layouts.....	787
Telephone Features Supported Across Server Edition and SCN Networks.....	788
Voicemail Support.....	789
Enabling Small Community Networking.....	790
Setup the VoIP Line from System A to System B.....	790
Setup the VoIP Line from System B to System A.....	792
Small Community Network Management.....	792
Enabling SCN Discovery.....	793
Creating a Common Admin Account.....	793
Loading a Small Community Network Configuration.....	794
Editing a Small Community Network Configuration.....	795
Using the Network Viewer.....	796
System Inventory.....	801
Small Community Network Remote Hotdesking.....	801
Small Community Network Fallback.....	802
SCN Short Code Programming.....	803
<b>Part 5: Short Codes.....</b>	<b>805</b>
<b>Chapter 17: Short Code Overview.....</b>	<b>806</b>
Short Code Characters.....	808
User Dialing.....	811
Application Dialing.....	814
Secondary Dial Tone.....	814
? Short Codes.....	816
Short Code Matching Examples.....	816
Default System Short Code List.....	821
<b>Chapter 18: Short Code Features.....</b>	<b>827</b>
Auto Attendant.....	830
Auto Intercom Deny Off.....	831
Auto Intercom Deny On.....	831
Break Out.....	832
Barred.....	832
Busy On Held.....	833
Call Intrude.....	834
Call Listen.....	834
Call Park.....	836

Call Park and Page.....	837
Call Pickup Any.....	837
Call Pickup Extn.....	838
Call Pickup Group.....	838
Call Pickup Line.....	839
Call Pickup Members.....	840
Call Pickup User.....	840
Call Queue.....	841
Call Record.....	842
Call Steal.....	842
Call Waiting On.....	843
Call Waiting Off.....	844
Call Waiting Suspend.....	844
Cancel All Forwarding.....	845
Cancel Ring Back When Free.....	845
Change Login Code.....	846
Clear After Call Work.....	847
Clear Call.....	847
Clear CW.....	848
Clear Hunt Group Night Service.....	848
Clear Hunt Group Out Of Service.....	849
Clear Quota.....	850
Coaching Intrusion.....	850
Conference Add.....	851
Conference Meet Me.....	852
CW.....	853
Dial.....	854
Dial 3K1.....	855
Dial 56K.....	855
Dial 64K.....	856
Dial CW.....	856
Dial Direct.....	857
Dial Direct Hot Line.....	857
Dial Emergency.....	858
Dial Extn.....	858
Dial Fax.....	859
Dial Inclusion.....	860
Dial Paging.....	861
Dial Physical Extension by Number.....	861
Dial Physical Extension By ID.....	862
Dial Speech.....	862
Dial V110.....	863
Dial V120.....	863

Dial Video.....	863
Disable ARS Form.....	864
Disable Internal Forwards.....	864
Disable Internal Forward Unconditional.....	865
Disable Internal Forward Busy or No Answer.....	865
Display Msg.....	866
Do Not Disturb Exception Add.....	867
Do Not Disturb Exception Delete.....	867
Do Not Disturb On.....	868
Do Not Disturb Off.....	869
Enable ARS Form.....	869
Enable Internal Forwards.....	870
Enable Internal Forward Unconditional.....	870
Enable Internal Forward Busy or No Answer.....	871
Extn Login.....	871
Extn Logout.....	872
Flash Hook.....	873
FNE Service.....	874
Follow Me Here.....	874
Follow Me Here Cancel.....	875
Follow Me To.....	875
Forward Hunt Group Calls On.....	876
Forward Hunt Group Calls Off.....	877
Forward Number.....	877
Forward On Busy Number.....	878
Forward On Busy On.....	879
Forward On Busy Off.....	879
Forward On No Answer On.....	880
Forward On No Answer Off.....	880
Forward Unconditional On.....	881
Forward Unconditional Off.....	882
Group Listen Off.....	882
Group Listen On.....	883
Headset Toggle.....	883
Hold Call.....	884
Hold CW.....	885
Hold Music.....	885
Hunt Group Disable.....	886
Hunt Group Enable.....	886
Last Number Redial.....	887
MCID Activate.....	887
Mobile Twinned Call Pickup.....	888
Off Hook Station.....	889

Outgoing Call Bar Off.....	889
Outgoing Call Bar On.....	890
Private Call Off.....	891
Private Call On.....	891
Priority Call.....	892
Record Message.....	892
Relay On.....	893
Relay Off.....	894
Relay Pulse.....	895
Resume Call.....	895
Retrieve Call.....	896
Ring Back When Free.....	896
Secondary Dial Tone.....	897
Set Absent Text.....	898
Set Account Code.....	899
Set Authorization Code.....	900
Set Fallback Twinning Off.....	900
Set Fallback Twinning On.....	900
Set Hunt Group Night Service.....	901
Set Hunt Group Out Of Service.....	902
Set Inside Call Seq.....	902
Set Mobile Twinning Number.....	903
Set Mobile Twinning On.....	904
Set Mobile Twinning Off.....	904
Set No Answer Time.....	904
Set Outside Call Seq.....	905
Set Ringback Seq.....	906
Set Time Profile.....	906
Set Wrap Up Time.....	908
Speed Dial.....	909
Shutdown Embedded Voicemail.....	909
Stamp Log.....	910
Startup Embedded Voicemail.....	910
Suspend Call.....	911
Suspend CW.....	911
Start After Call Work.....	912
Toggle Calls.....	912
Unpark Call.....	913
Voicemail Collect.....	913
Voicemail Node.....	916
Voicemail On.....	916
Voicemail Off.....	917
Voicemail Ringback On.....	918

Voicemail Ringback Off.....	918
Whisper Page.....	919
<b>Part 6: Button Programming.....</b>	<b>920</b>
<b>Chapter 19: Button Programming Overview.....</b>	<b>921</b>
Programming Buttons with Manager.....	921
Programming Button via the Menu Key.....	923
Setting a Button to Dial a Number.....	923
Setting a Button to a Switch Function.....	923
Setting Buttons to Admin Function.....	924
Programming Button via an Admin Button.....	925
Using an Admin Button.....	926
BST Button Programming.....	927
T3 Self-Administration.....	929
Interactive Button Menus.....	931
Label Templates.....	931
<b>Chapter 20: Button Programming Actions.....</b>	<b>933</b>
911-View.....	941
Abbreviated Dial.....	941
Abbreviated Dial Pause.....	942
Abbreviated Dial Program.....	943
Abbreviated Dial Stop.....	943
Absent Message.....	944
Account Code Entry.....	944
ACD Agent Statistics.....	945
ACD Stroke Count.....	945
Acquire Call.....	946
AD Special Functions.....	946
AD Special Function Mark.....	947
AD Special Function Wait.....	948
AD Suppress.....	948
After Call Work.....	949
Appearance.....	950
Automatic Callback.....	953
Auto-Intercom Deny.....	954
Automatic Intercom.....	954
Break Out.....	955
Bridged Appearance.....	956
Busy.....	957
Busy On Held.....	957
Call Forwarding All.....	958
Call Intrude.....	959
Call Listen.....	960
Call Log.....	961

Call Park.....	962
Call Park and Page.....	963
Call Park To Other Extension.....	964
Call Pickup.....	965
Call Pickup Any.....	966
Call Pickup Group.....	966
Call Pickup Members.....	967
Call Queue.....	968
Call Record.....	969
Call Screening.....	970
Call Steal.....	972
Call Waiting Off.....	973
Call Waiting On.....	974
Call Waiting Suspend.....	975
Cancel All Forwarding.....	975
Cancel Leave Word Calling.....	976
Cancel Ring Back When Free.....	977
Channel Monitor.....	977
Clear Call.....	978
Clear CW.....	978
Clear Hunt Group Night Service.....	979
Clear Hunt Group Out Of Service.....	980
Clear Quota.....	981
Coaching Intrusion.....	982
Conference.....	983
Conference Add.....	983
Conference Meet Me.....	984
Consult.....	986
Coverage Appearance.....	987
Dial.....	988
Dial 3K1.....	989
Dial 56K.....	989
Dial 64K.....	990
Dial CW.....	991
Dial Direct.....	991
Dial Emergency.....	992
Dial Inclusion.....	993
Dial Intercom.....	994
Dial Paging.....	995
Dial Physical Extn by Number.....	996
Dial Physical Number by ID.....	997
Dial Speech.....	997
Dial V110.....	998

Dial V120.....	999
Display Msg.....	999
Dial Video.....	1000
Directed Call Pickup.....	1001
Directory.....	1001
Do Not Disturb Exception Add.....	1002
Do Not Disturb Exception Delete.....	1003
Do Not Disturb Off.....	1004
Do Not Disturb On.....	1004
Drop.....	1005
Emergency View.....	1006
Extn Login.....	1007
Extn Logout.....	1008
Flash Hook.....	1009
Follow Me Here.....	1010
Follow Me Here Cancel.....	1011
Follow Me To.....	1012
Forward Hunt Group Calls Off.....	1013
Forward Hunt Group Calls On.....	1013
Forward Number.....	1014
Forward On Busy Number.....	1015
Forward On Busy Off.....	1016
Forward On Busy On.....	1017
Forward On No Answer Off.....	1018
Forward On No Answer On.....	1018
Forward Unconditional Off.....	1019
Forward Unconditional On.....	1020
Group.....	1021
Group Listen On.....	1022
Group Paging.....	1023
Headset Toggle.....	1024
Hold Call.....	1025
Hold CW.....	1026
Hold Music.....	1026
Hunt Group Enable.....	1027
Hunt Group Disable.....	1028
Inspect.....	1029
Internal Auto-Answer.....	1029
Last Number Redial.....	1030
Leave Word Calling.....	1031
Line Appearance.....	1032
MADN Call Appearance.....	1032
Manual Exclude.....	1034

MCID Activate.....	1035
Monitor Analogue Trunk MWI.....	1035
Off Hook Station.....	1036
Pause Recording.....	1037
Priority Call.....	1037
Priority Calling.....	1038
Private Call.....	1039
Relay Off.....	1039
Relay On.....	1040
Relay Pulse.....	1041
Resume Call.....	1042
Request Coaching Intrusion.....	1042
Retrieve Call.....	1043
Ring Back When Free.....	1044
Ringer Off.....	1045
Self-Administer.....	1046
Send All Calls.....	1049
Set Absent Text.....	1050
Set Account Code.....	1051
Set Hunt Group Night Service.....	1052
Set Hunt Group Out Of Service.....	1053
Set Inside Call Seq.....	1054
Set Night Service Destination.....	1054
Set No Answer Time.....	1055
Set Out of Service Destination.....	1056
Set Outside Call Seq.....	1057
Set Ringback Seq.....	1057
Set Wrap Up Time.....	1057
Speed Dial.....	1058
Stamp Log.....	1059
Stored Number View.....	1059
Suspend Call.....	1060
Suspend CW.....	1061
Swap CLID Name/Number.....	1061
Time of Day.....	1062
Time Profile.....	1063
Timer.....	1065
Transfer.....	1066
Toggle Calls.....	1066
Twinning.....	1067
Unpark Call.....	1068
User.....	1069
Visual Voice.....	1071



Voicemail Collect.....	1073
Voicemail Off.....	1074
Voicemail On.....	1075
Voicemail Ringback Off.....	1076
Voicemail Ringback On.....	1076
Whisper Page.....	1077
<b>Chapter 21: Appearance Button Operation.....</b>	<b>1079</b>
Appearance Button Features.....	1080
Call Appearance Buttons.....	1081
Call Appearance Example 1.....	1081
Call Appearance Example 2.....	1082
How are Call Appearance Buttons Treated?.....	1083
Call Appearance Button Indication.....	1084
Bridged Appearance Buttons.....	1086
Bridged Appearance Example 1.....	1086
Bridged Appearance Example 2.....	1087
Bridged Appearance Example 3.....	1088
How are Bridged Appearances Treated?.....	1089
Bridged Appearance Button Indication.....	1089
Call Coverage Buttons.....	1091
Call Coverage Example 1.....	1091
Call Coverage Example 2.....	1092
How is Call Coverage Treated?.....	1093
Call Coverage Button Indication.....	1094
Line Appearance Buttons.....	1095
Line Appearance Example 1.....	1096
Line Appearance Example 2.....	1096
How are Line Appearances Treated?.....	1097
Line Appearance Button Indication.....	1098
T3 Phone Line Appearances.....	1099
Selected Button Indication.....	1101
Idle Line Preference.....	1102
Ringing Line Preference.....	1104
Answer Pre-Select.....	1106
Auto Hold.....	1108
Ring Delay.....	1108
Delayed Ring Preference.....	1110
Collapsing Appearances.....	1112
Joining Calls.....	1113
Multiple Alerting Appearance Buttons.....	1115
Twinning.....	1116
Busy on Held.....	1117
Reserving a Call Appearance Button.....	1117

Logging Off and Hot Desking.....	1117
Applications.....	1118
Programming Appearance Buttons.....	1118
Appearance Function System Settings.....	1120
Appearance Function User Settings.....	1121
Programming Line Appearance ID Numbers.....	1122
Outgoing Line Programming.....	1124
<b>Part 7: Miscellaneous.....</b>	<b>1125</b>
<b>Chapter 22: Overview of Data Routing.....</b>	<b>1126</b>
Network Address Translation (NAT).....	1127
Dynamic Host Configuration Protocol (DHCP).....	1127
Simple ISDN Internet Connection.....	1128
ISDN Link Between IP Offices.....	1128
Using a Dedicated T1/PRI ISP Link.....	1129
Tasks for Using a Dedicated T1/PRI ISP Link.....	1129
Create a New WAN Service.....	1129
Create the Virtual WAN Port.....	1131
Create an IP Route.....	1131
T1 PRI Trunk.....	1132
Remote Access.....	1132
Creating a VoIP Link via the WAN Port Using PPP.....	1135
<b>Chapter 23: Appendix: SMDR.....</b>	<b>1137</b>
SMDR Fields.....	1139
SMDR Examples.....	1142
<b>Chapter 24: Resources.....</b>	<b>1151</b>
Documentation resources.....	1151
Finding documents on the Avaya Support website.....	1151
Support.....	1152
Using the Avaya InSite Knowledge Base.....	1152
Viewing Avaya Mentor videos.....	1152
Additional IP Office resources.....	1153

# Part 1: Introduction

# Chapter 1: Introduction

## Related links

[Purpose](#) on page 28

[New in Release 11.1](#) on page 28

[New in Release 11.1.SP1](#) on page 30

[New in Release 11.1.FP1](#) on page 31

---

## Purpose

This document contains descriptions of the configuration fields and the configuration procedures for administering Avaya IP Office Platform using the IP Office Manager application. This document principally covers Release 11.1 Feature Pack 1 of those products.

### Intended audience

The primary audience for the Administering Avaya IP Office using IP Office Manager is the customer system administrator. Implementation engineers and support and services personnel may also find this information helpful, however, they are not the primary audience.

## Related links

[Introduction](#) on page 28

---

## New in Release 11.1

### Avaya IX™ Workplace Client shared control

Avaya Workplace Client can now be used in shared control mode with desk phones. The shared control feature is available even when the Avaya Workplace Client and desk phones are registered on different systems within the same network.

### Join two Conferences

Conference Join feature allows two separate conferences to be joined into one single conference that contains all the previous participants of both the earlier conferences. Once the conferences have been joined it is not possible to revert to the two separate conferences again.

## JEM 24 button module support on Avaya J169/J179 IP Phone

Avaya J169/J179 IP Phone can support up to three JEM24 button modules. Each JEM24 has 24 dual-LED buttons with adjacent button label display. The button LEDs are used to indicate the status of the button feature whilst pressing the button is used to access the feature. A single JEM24 supports 72 programmable button slots. These are arranged in 3-pages, with pages accessed using the module's page scroll button. When multiple modules are connected to a phone, each module only supports a single page of 24 programmable button slots.

The modules automatically match the display settings of the phone to which they are connected - color with Avaya J179 IP Phone or greyscale with Avaya J169 IP Phone, font size, background image, screen saver. The button modules are powered through the phone. For more information, see the *IP Office Platform R11.0 J100 Series Telephone User Guide*.

## Avaya J159

IP Office support for Avaya J159 IP Phone is an advanced SIP desk phone that supports dual displays.

- Primary display:
  - 2.8" Color display (320 x 240).
  - 24 programmable button slots for call appearance and feature buttons.
  - The button slots can be arranged in either dual-column mode single column mode.
  - 4 twin-LED (red and green) physical buttons are used to indicate the status of the programmable button slots currently in view on the display.
- Secondary display:
  - 2.3" Color display (160 x 240).
  - 24 programmable button slots for call appearance and feature buttons.
  - The button slots are arranged in 4–pages of 6.
  - 6 twin-LED (red and green) physical buttons are used to indicate the status of the programmable button slots currently in view on the display.

## Avaya push notifications

Avaya Push Notification service (APNs) is a platform notification service created by Apple Inc. This service allows iOS users of Avaya Workplace Client to receive notification of new calls, voicemail messages, and other events. They receive these notifications regardless when the Avaya Workplace Client is idle in the background or is in quit state. However, if Avaya Workplace Client is on suspension, then Avaya Workplace Client automatically starts when a new call or instant message notification arrives.

## Avaya cloud authorization

Using Avaya cloud authorization, you can configure the Avaya Workplace Client connection using your Google, Office 365, Salesforce account, Avaya native spaces email account, or Enterprise Account (SSO).

You can configure the Avaya Workplace Client settings automatically using your email address or the automatic configuration web address.

## Consent Directive

This field is used to control the addition of a consent value to the system's SMDR output and CTI call logging outputs.

## Subscription Based Licensing

Systems can now be installed in IP Office Subscription mode. This mode uses subscription based licensing, that is, licenses paid for on a per-user per-month basis.

## End of Windows 7 Support

Microsoft has ended support for this operating system (other than security updates for those with extended support agreements). Therefore, support of IP Office applications on this operating system has ended.

### Related links

[Introduction](#) on page 28

---

## New in Release 11.1.SP1

The following addition changes apply for R11.1 SP1 and higher systems:

### 911-View/Emergency View Button

IP Office R11.1 SP1 adds support for an emergency call view button. This function allows you to view details of emergency calls in progress or previously made from the system. See [Emergency View](#) on page 1006.

### Vantage Connect Expansion Module Application

IP Office R11.1 SP1 adds support for the Vantage Connect Expansion Module Application (with Vantage firmware 2.2 SP3). The application displays a list of programmable button features configured for the user.

The application can be run on the same Vantage phone as the user's Vantage Connect application, or on another Vantage phone. For full details and a list of supported programmable button features, refer to the *SIP Telephone Installation Notes* manual.

### Call Pickup Group Member – Status Indication

IP Office R11.1 SP1 adds support for status indication on **Call Pickup Group Member** programmable buttons. The button LED flashes when a call to any member of the group, including non-group calls, is waiting to be picked up.

On suitable phones, pressing the button displays a list of any currently ringing group members and can be used to select which to pickup.

### Avaya Cloud Services URL Change

The URL for Avaya Cloud Services have changed from `accounts.zang.io` to `accounts.avayacloud.com`. The URL field is now editable, however the previous URL remains supported for existing systems. New systems will default to the new URL.

## Subscription Remote Worker Option

On subscription based systems, the **Remote Worker** option is now supported for all user subscriptions.

## Retain Configuration on by Default

On existing systems, when rerunning the initial configuration utility, the **Retain Configuration** option is now enabled by default.

## Support for AWS and Hyper-V Virtual Server Images

IP Office R11.1 SP1 is available for installation from AWS virtual server images in addition to the existing VMware image support.

## Support for Powered By IP Office

IP Office R11.1 SP1 is supported through the Powered By IP Office program.

## Avaya Workplace Client CTI Control

The Avaya Workplace Client clients are now supported as a client using CTI control from other IP Office applications such as, SoftConsole, one-X Portal for IP Office, Avaya Contact Center Select, and IPOCC.

### Related links

[Introduction](#) on page 28

---

## New in Release 11.1.FP1

### Avaya J189 IP Phone

Avaya J189 IP Phone is a SIP-based phone for business communications. The phone has 10 line keys for programming with 48 feature keys, displayed in pages of 10 on the main display. Buttons 25-48 are directly accessible via the internal Quick Dial Display (QDD).

The following are the physical specifications of the phone:

- Two color display
  - Primary display-800 x 480 pixels
  - Secondary display-240 x 320 pixels
- Dual Port Gigabit Ethernet (10/100/1000) line with Second Ethernet and RJ45 Connectors.
- The primary display has five call appearances in full-screen mode and ten call appearances in dual screen mode.
- The phone supports Wideband audio, full-duplex speakerphone, wired handset, headset, and ergonomic hearing aid.
- The primary display has four soft keys.
- The secondary display has six programmable buttons.
- Optional 5V DC power support

- Magnetic hook switch
- The phone has ten status indicator.
- The primary display has four menu navigation buttons, and the secondary displays two navigation buttons.

The secondary display of the phone provides additional call appearances and feature or application display. It has six lines of four-page display that provides 24 additional lines for incoming calls, outgoing calls, auto-dialing, and calling features. It displays the dedicated view for keys 25-48. You can switch between the pages using the left and right keys.

## Server Edition Initial Configuration

For Server Edition (Non Select) or (Select) mode the conversion to Subscription mode can be achieved by rerunning **Initial Configuration** menu.

## Security Settings

- Logging in to Web Manager: **Login History**

When logging in, details of the users information about the last login attempt, with date and time are displayed.

- General Security Settings: For Service Users and IP Office Users, the following security setting values are increased:
  - The **Minimum Password Length** is 9 characters.
  - The **Previous Password Limit (Entries)** is 10 records.
- Application Preferences: The default values for **Inactivity Timeout** is now 10 minutes.
- Added two configuration in **Security Manager > Certificates**.
  - **Automatic Certificate Management**
  - **Automatic Phone Provisioning**

## System Configurations

Added the following configuration settings:

- **System > System > HTTP Server URI**
- **Group > Fallback > Group No Answer Destination**
- **Group > Fallback > Group No Answer Time**

## Voicemail Password

For IP Office 11.1 FP1 version and higher, the password for voicemail connection is enforced to 31 characters

## Related links

[Introduction](#) on page 28



# Chapter 2: Overview

This documentation covers the use of the Avaya IP Office Manager. Manager runs on a Windows PC and connects to the IP Office system via Ethernet LAN or WAN connections.

## Important:

Manager is an off-line editor. It receives a copy of the system's current configuration settings. Changes are made to that copy and it is then sent back to the system for those changes to become active. This means that changes to the active configuration in the system that occur between Manager receiving and sending back the copy may be overwritten. For example, this may affect changes made by a user through their phone or voicemail mailbox after the copy of the configuration is received by Manager.

## Related links

[Manager Modes](#) on page 33

---

## Manager Modes

The menus and options displayed by Manager vary depending on the actions you are performing. Manager runs in the following modes:

### **Basic Edition Mode**

This is the mode used when a Basic Edition configuration is opened. Basic Mode includes systems running Partner, Norstar, or Quick Mode. For information on administering a Basic Edition system, see the IP Office Basic Edition Manager.

### **Security Configuration Mode**

Manager can be used to edit the security settings of IP Office systems.

### **Standard Mode Configuration Mode**

This is the mode used when a Standard Mode configuration is opened. Standard Mode includes systems running Standard, Preferred, or Advanced Edition.

### **Server Edition Configuration Mode**

This is the mode used when an IP Office Server Edition network configuration is opened.

## Small Community Network Management

Manager supports loading the combined configurations from systems in a Small Community Network.

## IP Office Shell Server Mode

The IP Office Shell Server is a single installation of selected IP Office applications running on Linux. You can use Manager to administer an IP Office Shell Server.

## Embedded File Management

For systems with a memory card installed, Manager can be used to view and manage the files stored on the card. Embedded File Management can be accessed by selecting **File | Advanced | Embedded File Management**.

## Upgrade Wizard

The Upgrade Wizard is a component of Manager used to upgrade the firmware run by the system.

### Related links

[Overview](#) on page 33

[Security Configuration Mode](#) on page 34

[Standard Mode Configuration Mode](#) on page 35

[Server Edition Configuration Mode](#) on page 37

[Shell Server Mode](#) on page 38

[Backward Compatibility](#) on page 39

---

## Security Configuration Mode

When Manager is in Security Mode, the screen elements shown are available.

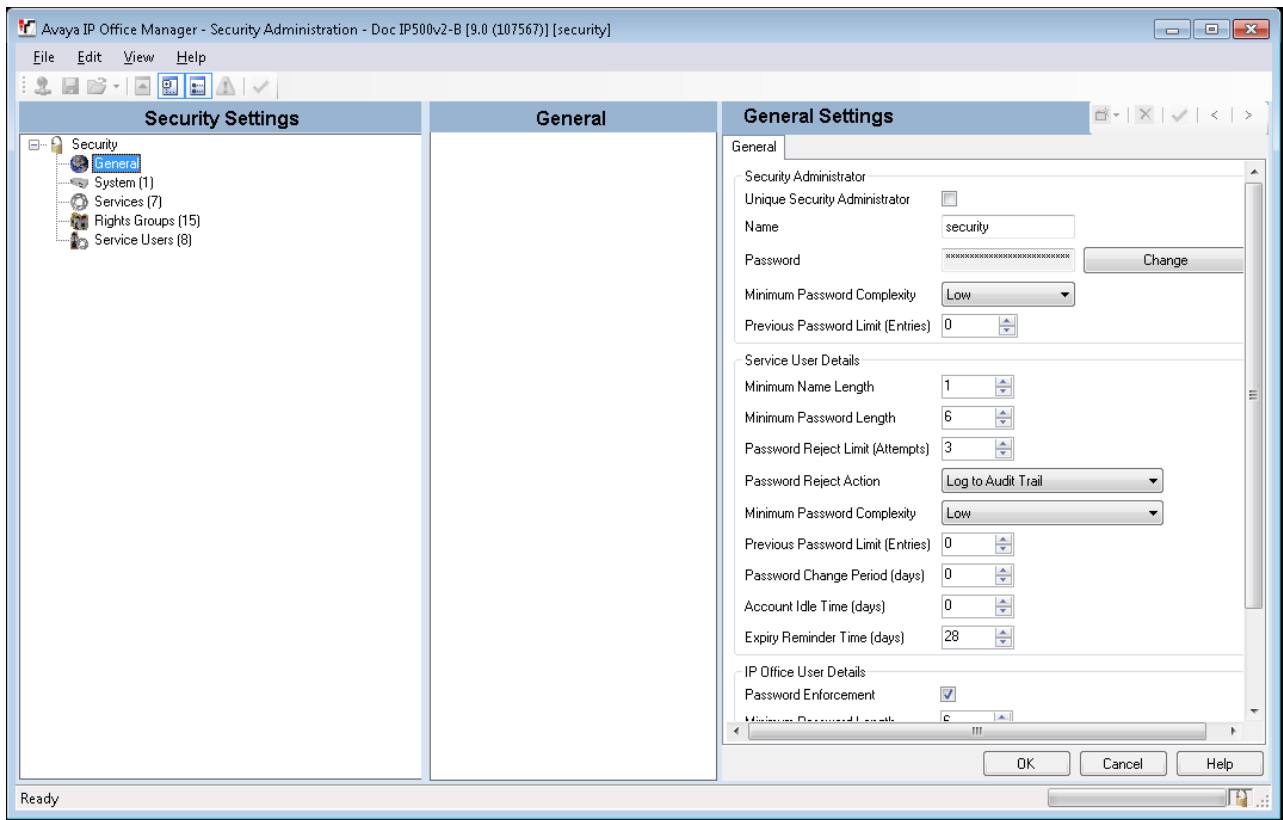

**Related links**

[Manager Modes](#) on page 33

---

**Standard Mode Configuration Mode**

When Manager is in configuration mode, the screen elements shown are available. Some of these elements can be customized, moved and hidden.

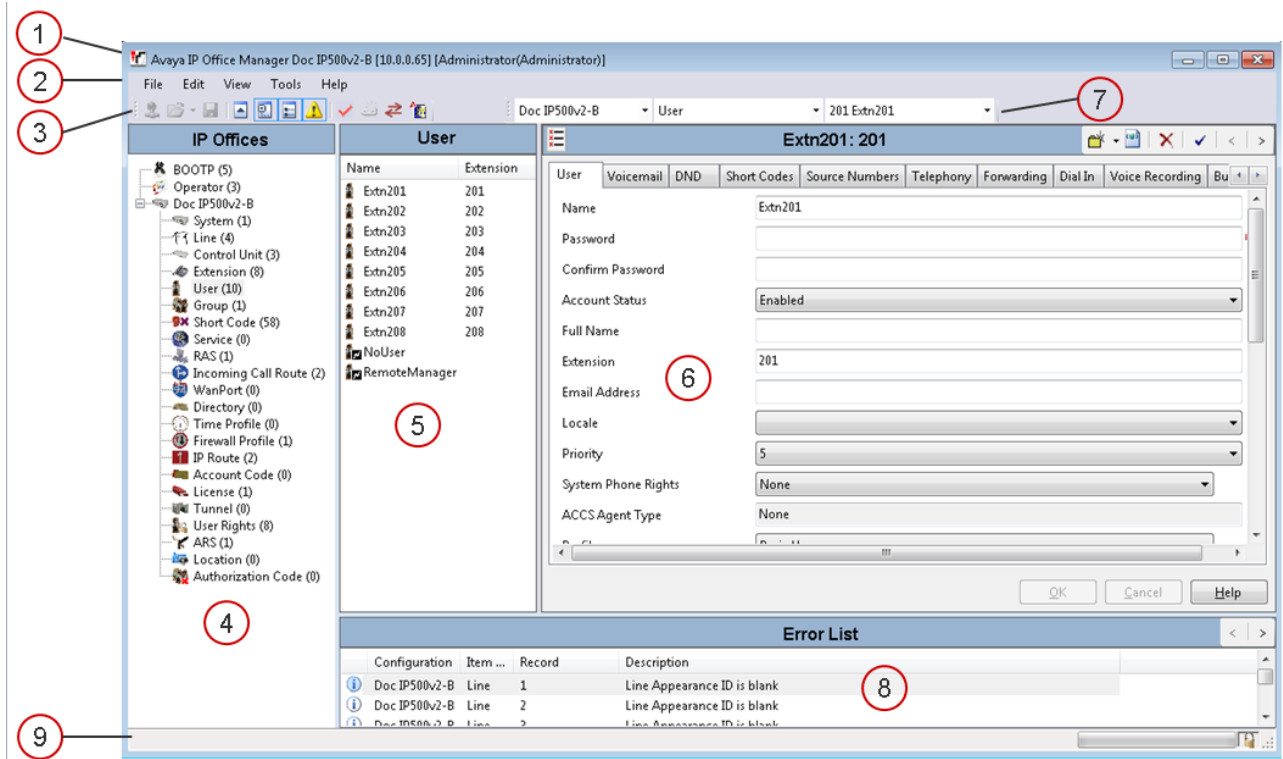

**Manager Configuration Mode Screen Elements**

1	<p><b>Title Bar</b></p> <p>In addition to the application name, when configuration settings are loaded from a system, the title bar displays the user name used to load the settings and the operator view applied.</p>
2	<p><b>Menu Bar</b></p> <p>The options available with the drop down menus provided here change according to whether Manager has a set of configuration or security settings loaded or not.</p>
3	<p><b>Main Toolbar</b></p> <p>This toolbar provides icon shortcuts to the most frequently required configuration setting actions.</p>
4	<p><b>Navigation Pane</b></p> <p>This pane shows icons for the different types of record that the configuration can contain. Each type is followed by the number of records of that type already in the configuration. Selecting an icon displays the matching records in the group pane and navigation toolbar.</p>
5	<p><b>Group Pane</b></p> <p>This pane lists all the records that match the type selected in the navigation pane or navigation toolbar. The list can be sorted by clicking on column heading. Selecting a record in this pane displays its details in the details pane.</p>

*Table continues...*

6	<p><b>Details Pane</b></p> <p>This pane shows the configuration settings for a particular record within the configuration. The record is selected using the navigation toolbar or using the navigation pane and group pane.</p>
7	<p><b>Navigation Toolbar</b></p> <p>This toolbar provides a set of drop downs which can be used to navigate to particular records in the configuration settings. The selected options in the navigation pane, the group pane and the details pane are synchronized with the navigation toolbar and vice versa. This toolbar is particularly useful if you want to work with the group pane and or navigation pane hidden in order to maximize the display space for the details pane.</p>
8	<p><b>Error Pane</b></p> <p>This pane shows errors and warnings about the configuration settings. Selecting an item here loads the corresponding record into the details pane.</p>
9	<p><b>Status Bar</b> This bar display messages about communications between Manager and systems. It also displays the security level of the communications by the use of a padlock icon.</p>

### Related links

[Manager Modes](#) on page 33

---

## Server Edition Configuration Mode

When the configuration from a Server Edition solution is loaded into Manager, Manager switches to Server Edition mode operation.

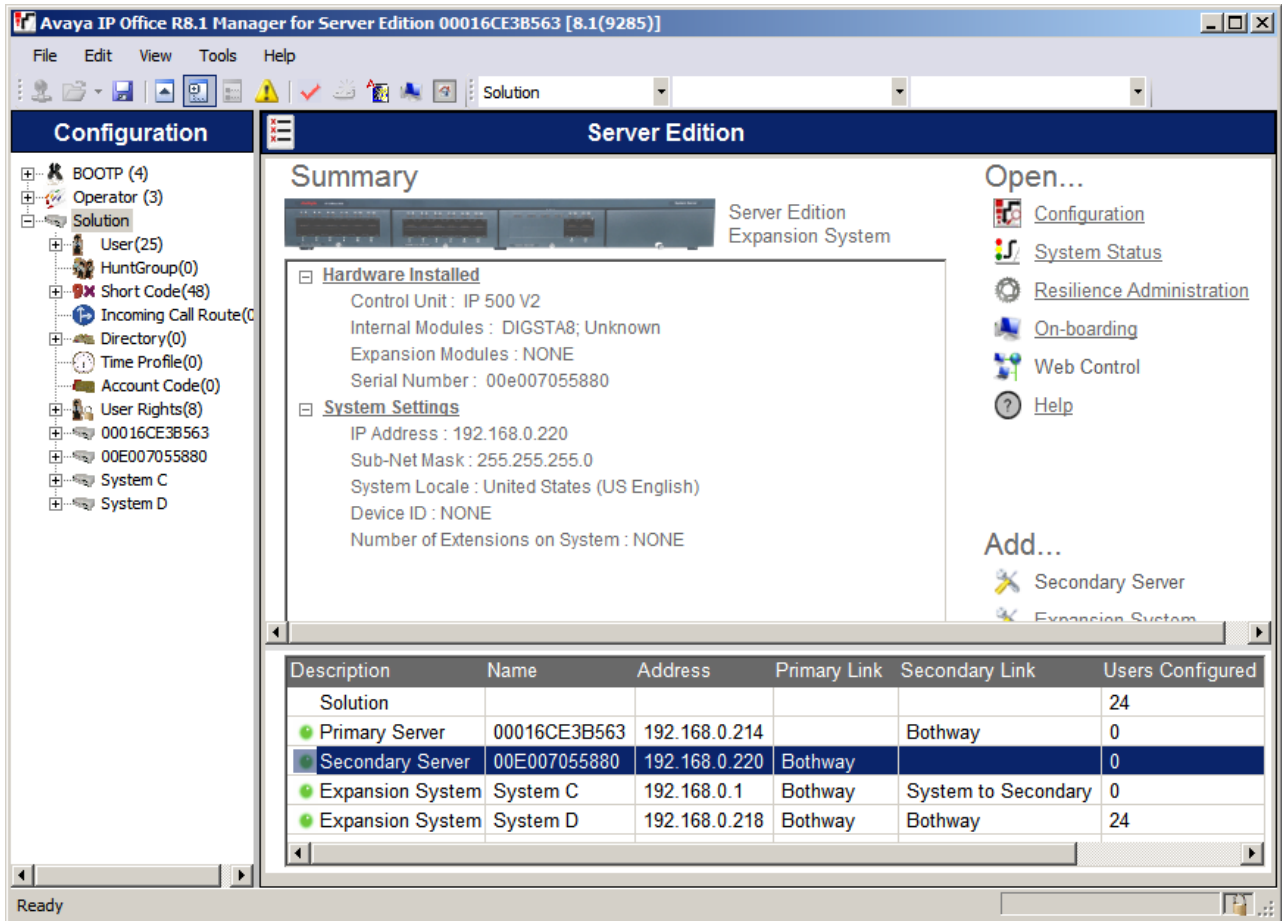

**Related links**

[Manager Modes](#) on page 33

## Shell Server Mode

An IP Office Shell Server is a single installation of selected IP Office applications running on Linux. You can use Manager to configure and administer a Shell Server. Application Servers and Unified Communications Modules (UCM) run on an IP Office Shell Server.

Since a Shell Server does not provide telephony, when you open a Shell Server configuration in Manager, all telephony functions are disabled. The following Manager functions are supported for Shell Servers:

- Discovery
- Initial configuration utility.
- System status.
- Load, edit and save security settings.

- Load, edit, and save the configuration.
- Erase configuration and security settings.
- Audit trail display.
- Web Control.

For more information on the management of an IP Office Shell Server, see *Installing and Maintaining Avaya IP Office™ Platform Application Server* and *Installing Avaya IP Office™ Platform Unified Communications Module*.

#### Related links

[Manager Modes](#) on page 33

---

## Backward Compatibility

Manager is part of the IP Office Admin Suite of programs. The Manager application can be used to manage configurations from systems running earlier software releases. Manager adjusts the settings and fields that it shows to match the core software level of the system.

Manager is able display systems with software levels it does not support in the **Select IP Office** discovery menu, however those systems are indicated as not supported.

Backwards compatibility is only supported for General Availability releases of IP Office software. It is not supported for private builds.

Note that this document describes the current release. If you are running an earlier software release, obtain the Manager document for the specific release from the Avaya support site.

#### Related links

[Manager Modes](#) on page 33

# Chapter 3: Getting Started

## Related links

[PC requirements](#) on page 40

[Installing Manager](#) on page 41

[Starting Manager](#) on page 43

[Opening a Configuration](#) on page 44

[Changing the Manager Language](#) on page 47

---

## PC requirements

### Supported Operating Systems

- Windows 8.1
- Windows 10
- Windows Server 2012 R2
- Windows Server 2016

 **Note:**

IP Office Manager supports Windows only with the display font size set to 100%.

### Minimum PC Requirements

IP Office System	System RAM (minimum or higher)	Available memory required for Manager operations	Minimum free hard disk space	Processor (similar or higher)	Network size supported
Standard Mode	4 GB	2 GB	6 GB	Intel® Core™ i3 or equivalent, 2 GHz minimum	Not applicable.
Server Edition	4 GB (32 bit OS)	2 GB	6 GB	Intel® Core™ i3 or equivalent, 2 GHz minimum	Up to 32 nodes
Server Edition	8 GB (64 bit OS)	4 GB	6 GB	Intel® Core™ i5 or equivalent, 2 GHz minimum	Up to 150 nodes



## Applications

If not already present, the required version of .NET Framework is installed as part of the IP Office Manager installation.

## Ports

For information on port usage see the IP Office Port Matrix document on the Avaya support site at <https://support.avaya.com/helpcenter/getGenericDetails?detailId=C201082074362003>

## Related links

[Getting Started](#) on page 40

---

# Installing Manager

Manager is a component of the IP Office Admin suite of applications. This suite is supplied on the Software DVD (Disk 1). Alternatively, the IP Office Admin Suite can be downloaded from Avaya's support website <http://support.avaya.com>.

In addition to Manager, the Admin suite includes options to install the following applications:

- **System Monitor** This is a tool for system installers and maintainers. Interpreting the information output by System Monitor requires detailed data and telecoms knowledge.
- **System Status Application** This is a Java application that can be used to monitor the status of the system such as extension, trunks and other resources. It displays current alarms and most recent historical alarms.

### Note:

This installation process will install the required version of Windows .NET if not already present. This may require some systems to restart and the installation process to then be restarted.

## Procedure

1. If installing from the Admin DVD, insert the DVD and when the page is displayed click on the link for the Admin suite. This will open a file windows showing the installation files for the suite.
2. Locate and right-click on the `setup.exe` file. Select **Run as Administrator**.
3. Select the language you want to use for the installation process. This does not affect the language used by Manager when it is run. Click **Next >**.
4. If an upgrade menu appears, it indicates that a previous installation has been detected. Select **Yes** to upgrade the existing installed applications.
5. If required select the destination to which the applications should be installed. We recommend that you accept the default destination. Click **Next >**.
6. The next screen is used to select which applications in the suite should be installed. Clicking on each will display a description of the application. Click on the ▼ next to each

application to change the installation selection. When you have selected the installations required, click **Next >**.

7. The applications selected are now ready to be installed. Click **Next >**.
8. Following installation, you will be prompted whether you want to run Manager. Selecting **Yes** runs Manager.
9. On some versions of Windows, you may be required to restart the PC. Allow this to happen if required.

### Related links

[Getting Started](#) on page 40

[Downloading Manager AdminLite](#) on page 42

---

## Downloading Manager AdminLite

### About this task

In addition to Manager, the Admin suite, IPOAdminLite, is also available for users to configure Manager applications.

Unlike the Admin suite, IPOAdminLite does not have all the bin files and firmware. It is purely the Manager application for configuring systems.

The following are the limitations of IPOAdminLite as compared to the full Admin suite.

- **Help files:** Only the English language `The Manager.chm` help file is present in the `IPOAdminLite.exe` installation, and other language variants are not present. Also mode specific chm help files for Partner, quick, norstar mode are not present in the `IPOAdminLite.exe`.
- **Phone file:** Phone bin files are not present in the `IPOAdminLite.exe` installation. Also, other phone-related xml and settings.txt files are not present with the `IPOAdminLite.exe` installation.
- **Memory cards folder :** Memory cards folder is missing in the `IPOAdminLite.exe` installation because of which your will not be able to upgrade system files or Web Manager files using IPOAdminLite Manager. Also, the user will not be able to recreate SD card with the `IPOAdminLite.exe` installation.

### Before you begin

Ensure you have administrator credentials.

### Procedure

To download `IPOAdminLite.exe` from COM server.

COM is accessed via web browser. It is supported with the current releases of Chrome, Explorer, Edge and Firefox browsers.

1. Start your browser and enter `https://` followed by the COM server's IP address or name followed by `:7080/com`. For example `https://admin.example.com:7080/com`.

2. Enter the administrator credentials.
3. Click **Applications > IP Office Admin Tools** and click **IPOAdminLite**.
4. Click **Download**.

 **Tip:**

You can also download `IPOAdminLite.exe` from Web Manager.

- a. Go to Web Manager and enter the administrator credentials.
- b. Click **AppCenter** and click **AdminLite.exe**.

### Next steps

Manually transfer the downloaded `IPOAdminLite.exe` file to the System Manager server and install AdminLite on the administration computer.

### Related links

[Installing Manager](#) on page 41

---

## Starting Manager

No name or password is required to start Manager. A name and password is only required when connecting with a system.

When started, by default Manager will attempt to discover any systems on the network. If it finds any it will display a list from which you can select the system required.

1. Select **Start** and then **Programs** or **All Programs** depending on the version of Windows. Select the **IP Office** program group.
2. Select  **Manager**. If a Windows Security Alert appears select **Unblock** to allow Manager to run.
3. By default Manager will scan the network for any systems. What appears next depends on whether it finds any systems.
  - If Manager finds multiple systems, the Select IP Office window displays a list of those systems from which you can select the one whose configuration you want to edit. If you want to open a configuration go to Opening a Configuration. If you don't want to load a configuration click on **Cancel**.
  - If it finds a single system, it will attempt to open the configuration of that system by displaying the Configuration Service User Login window..
  - If no systems are found or you cancel the steps above, the Manager simplified view is displayed.

Use the simplified view to select one of the following action.

- Create an Offline Configuration

- Open a Configuration from a System
- Read a Configuration from a File

### Related links

[Getting Started](#) on page 40

---

## Opening a Configuration

The initial IP address ranges in which Manager searches for systems is set through the **File | Preferences | Discovery**. By default, Manager scans the local network of the Manager PC.

1. Start Manager. If Manager is already started and a configuration is open in it, that configuration must be closed first.

If Manager is set to Auto Connect on start up, it will scan for systems automatically and either display the list of systems discovered or automatically start login to the only system discovered.

Otherwise, select **File | Open Configuration**.

2. The Select IP Office window opens, listing those systems that responded.
  - If Server Edition systems are detected, they are grouped together. By default the configuration of those systems cannot be opened using Manager in **Advanced View** mode and the configuration of a Primary Server can only be opened if the **Open with Server Edition Manager** option is also selected.
  - If Manager has been set with **SCN Discovery** enabled, systems in a Small Community Network are grouped together. The checkbox next to the network name can be used to load the configurations of all the configurations into Small Community Network management mode.
  - If the system required was not found, the **Unit/Broadcast Address** used for the search can be changed. Either enter an address or use the drop-down to select a previously used address. Then click **Refresh** to perform a new search.
  - A list of known systems can be stored using **Known System Discovery**.
  - Manager can be configured to search using DNS names.
  - Systems found but not supported by the version of Manager being used will be listed as **Not Supported**.
  - If the system detected is running software other than from its primary folder, a  warning icon will be shown next to it. The configuration can still be opened but only as a read-only file.
3. When you have located the system required, check the box next to the system and click **OK**.

If the system selected is a Server Edition system and Manager is not running in Server Edition mode, an **Open with Server Edition Manager** checkbox is shown and pre-

selected. Clicking **OK** will switch Manager to its Server Edition mode before loading the configuration.

4. The system name and password request is displayed. Enter the required details and click **OK**.

The name and password used must match a service user account configured within the system's security settings.

5. Additional messages will inform you about the success or failure of opening the configuration from the system.

The method of connection, secure or insecure, attempted by Manager is set the applications Secure Communications preferences setting.

- When **Secure Communications** is set to **On**, a  padlock icon is displayed at all times in the lower right Manager status field.
- New installations of Manager default to having **Secure Communications** enabled. This means Manager by default attempts to use secure communications when opening a configuration.
- For Server Edition systems, Manager will always attempt to use secure communications regardless of the **Secure Communications** setting.
- If no response to the use of secure communication is received after 5 seconds, Manager will offer to fallback to using unsecured communications.

6. Following a successful log in, the configuration is opened in Manager. The menus and options displayed will depend on the type of system configuration loaded.

### Related links

[Getting Started](#) on page 40

[Login messages](#) on page 45

---

## Login messages

While attempting to login to a system, various messages may be displayed.

### Login History

When logging in, user information details about the last login attempt, with date and time are displayed.

### Security Banner

You can set up an IP Office Manager security banner to include custom text. For example:

- Informative messages: To indicate the server role in a network, this may be useful in a network with multiple servers.
- Warning messages: To indicate a warning to restrict any system modification during the upgrade or backup process.
- General purpose messages: To indicate unauthorized access or system security restrictions.

For example: This system is restricted solely to authorized users for legitimate business purposes. The actual or attempted unauthorized access, use, or modification of this system is strictly prohibited.

To set up a security login banner, before logging into the IP Office Manager, do the following:

1. Open a `.txt` file.
2. Enter the required custom text.
3. Save it as `etcissue.txt` in the default IP Office installation folder that is `C:\Program Files(x86)\Avaya\IP Office\Manager`.

You can find the default IP Office installation folder at **File > Preferences > Working Directory**.

## Configuration Not Loaded Messages

### Access Denied

Displayed as the cause if the service user name/password were incorrect, or the service user has insufficient rights to read the configuration. The Retry option can be used to log in again but multiple rejections in a 10 minute period may trigger events, such as locking the user account, set by the Password Reject Limit and Password Reject Action options in the systems security settings.

### Failed to communicate with system

Displayed as the cause if the network link fails, or the secure communication mode is incorrect (for example Manager is set to unsecured, but the system is set to secure only).

### Account Locked

The account of the service user name and password being used is locked. This can be caused by a number of actions, for example too many incorrect password attempts, passing a fixed expiry date, etc. The account lock may be temporary (10 minutes) or permanent until manually unlocked. An account can be enabled again through the system's security settings.

## Additional Messages

### Your service user account will expire in X days

Indicates that an Account Expiry date has been set on the system service user account and that date is approaching. Someone with access to the system's security settings will be required unlock the account and set a new expiry date.

### Your password will expire in X days. Do you wish to change it now?

Indicates that password ageing has been configured in the system's security settings. If your password expires, someone with access to the system's security settings will be required to unlock the account.

**Limit of concurrent sessions per user exceeded:** Indicates that the administrator account has been used for more than five concurrent sessions. IP Office allows five concurrent sessions using one administrator account. If five sessions are already on, logging in for the sixth session fails and Web Manager displays an error message `Limit of concurrent sessions per user exceeded`. Note that the following are also considered as a session:

- If Manager is connected with IP Office Server Edition through SE Central Access.

- If the same administrator account is used to log in to any of the IP Office third party applications developed using the Management SDK client.

### Change password

Through the system's security settings, a service user account can be required to change their password when logging in. The menu provides fields for entering the old password and new password.

### Contact Information Check - This configuration is under special control

This message displays if a Manager user with administrator rights has entered their contact information into the configuration. For example to indicate that they do not want the configuration altered while a possible problem is being diagnosed. The options available are:

- **Cancel** Select this option to close the configuration without making any changes.
- **Set configuration alteration flag** Select this option if the configuration is being opened because some urgent maintenance action. When the configuration is next opened, the fact that it has been altered will be indicated on the **System > System** tab.
- **Delete Contact Information** Select this option to take the system out of special control.
- **Leave contact information and flags unchanged (Administrators only)** This option is only available to service users logging in with administrator rights.

### Related links

[Opening a Configuration](#) on page 44

## Changing the Manager Language

### About this task

The Manager application can run in multiple languages. By default it tries to use the best match to the PC's regional location settings, otherwise it uses UK English.

The process below can be used to run Manager in one of its supported languages. Some components in the application such as the error pane, tooltips, and pop-up messages continue to use the System Locale language.

### \* Note:

The IPOAdminLite does not support other languages. Only English language `Manager.chm` help file is present in `IPOAdminLite.exe` installation.

### Procedure

1. Create a Windows shortcut to the Manager application `.exe` file. By default this file is located in **C:\Program Files\Avaya\IP Office\Manager\Manager.exe**.
2. Right-click on the shortcut and select **Properties**.
3. The **Target** field can be used to specify the locale setting that Manager should use.

For example, for Italian the Target should have **-locale:it-IT** added to the end. For example: **"C:\Program Files\Avaya\IP Office\Manager\Manager.exe" -locale:it-IT**.

4. Click **OK**.
5. Manager should now run in the selected language when launched using the updated shortcut.

### Example

**Table 1: Manager Locales**

Manager Language	Shortcut Locale Setting
Brazilian Portuguese	-locale:pt-Br
Chinese (Simplified)	-locale:zh-Hans
Dutch	-locale:nl-NL
French	-locale:fr-FR
German	-locale:de-DE
Italian	-locale:it-IT
Mexican Spanish	-locale:es-MX
Russian	-locale:ru-RU
US English	-locale:en-US

### Related links

[Getting Started](#) on page 40



# Chapter 4: Menu Bar Commands

The commands available through the Manager's menu bar change according to the mode in which Manager is running. Commands may also be grayed out if not currently applicable. For some commands, an arrow symbol indicates that there are sub-commands from which a selection can be made.

The following sections outline the functions of each command. The **Edit** and **Help** menus are not included.

## Related links

- [File Menu](#) on page 49
- [View Menu](#) on page 81
- [Tools Menu](#) on page 82
- [Security Mode Menus](#) on page 88
- [Embedded File Management Menus](#) on page 89

---

## File Menu

### Related links

- [Menu Bar Commands](#) on page 49
- [File > Open Configuration](#) on page 50
- [File > Close Configuration](#) on page 50
- [File > Save Configuration](#) on page 50
- [File > Save Configuration As](#) on page 52
- [File > Change Working Directory](#) on page 52
- [File > Preferences](#) on page 53
- [File > Offline](#) on page 62
- [File > Advanced](#) on page 63
- [File > Backup/Restore](#) on page 80
- [File > Import/Export](#) on page 80
- [File > Exit](#) on page 81

## File > Open Configuration

This command displays the Select IP Office window used to receive a systems configuration settings.

The same action is performed by the  icon in the Main Toolbar.

The **Select IP Office** menu is also used for other actions such as reboot and sending a configuration. If the unit required is not found, the Unit/Broadcast Address can be changed and then Refresh clicked. To change the TCP addresses scanned, select **File | Preferences | Discovery** and enter the required addresses in the IP Search Criteria.

Known Units is not available unless configured

### Related links

[File Menu](#) on page 49

---

## File > Close Configuration

This command closes the currently loaded configuration without saving it.

### Related links

[File Menu](#) on page 49

---

## File > Save Configuration

The **File > Save Configuration** command saves the amended configuration.

If the configuration has been received from a system, the Send Config menu is displayed.

If the configuration file has been opened offline or created from new, the file is saved to disk only.

### Related links

[File Menu](#) on page 49

[Saving Server Edition Configuration Changes](#) on page 50

## Saving Server Edition Configuration Changes

After making configuration changes using Manager, the process of saving the changes performs several actions:

- The configurations are validated for consistency.
- For those systems for which configuration changes have been made, the new configuration is sent to that system.

Manager defaults to rebooting those systems where a reboot is necessary for the configuration changes to come into effect.

A time stamped copy of the new configuration is also stored on the Primary Server server.

- For a new Secondary Server or expansion system added to the network configuration using the create off-line configuration option, the offline file is stored, allowing the new system to be configured even though not yet physically present.
- When opening the configuration from a network, if the timestamp of the stored copy differs from that of the actual system configuration, Manager will prompt for which configuration it should load for editing.

## Saving Configuration Changes

1. Click  in the main toolbar or select **File | Save Configuration** from the menu bar.
  2. The menu displayed only shows details for those systems where the system configuration has been changed and needs to be sent back to the system.
- **Select** By default all systems with configuration changes are selected. If you want to exclude a system from having its configuration updated, either deselect it or cancel the whole process.
  - **Change Mode** If Manager thinks the changes made to the configuration settings are mergeable, it will select **Merge** by default, otherwise it will select **Immediate**.
  - **Merge** Send the configuration settings without rebooting the system. This mode should only be used with settings that are mergeable. Refer to Mergeable Settings.
  - **Immediate** Send the configuration and then reboot the system.
  - **When Free** Send the configuration and reboot the system when there are no calls in progress. This mode can be combined with the **Incoming Call Barring** and **Outgoing Call Barring** options.
  - **Store Offline** It is possible to add a reference for a Server Edition Secondary or for a Server Edition Expansion System to create a configuration file for that system even though it is not physically present. Store Offline saves that configuration on the Server Edition Primary in its file store. The same file is retrieved from there until such time as the physical server is present at which time you are prompted whether to use the stored file or the actual servers current configuration.
  - **Timed** The same as **When Free** but waits for a specific time after which it then wait for there to be no calls in progress. The time is specified by the **Reboot Time**. This mode can be combined with the **Incoming Call Barring** and **Outgoing Call Barring** options.
  - **Reboot Time** This setting is used when the reboot mode **Timed** is selected. It sets the time for the system reboot. If the time is after midnight, the system's normal daily backup is canceled.
  - **Incoming Call Barring** This setting can be used when the reboot mode **When Free** or **Timed** is selected. It bars the receiving of any new calls.
  - **Outgoing Call Barring** This setting can be used when the reboot mode **When Free** or **Timed** is selected. It bars the making of any new calls.

Click **OK**. The progress of the sending of each configuration is displayed.

## Related links

[File > Save Configuration](#) on page 50

## File > Save Configuration As

The **File > Save Configuration As** command allows you to save a configuration a file on the Manager computer. Note that dynamic configuration data, for example hunt groups advertised from other systems in a network, are not included in a configuration file saved onto PC and then reopened.

The command displays the Save As window. Select the drive and directory, and then enter the new file name. Once you have entered the file name, the Save Configuration File window opens, where you have the option to encrypt the file by entering a password. Leave the password blank if you do not want to encrypt the file.

 **Important:**

Encrypted configuration files can only be opened with Manager 9.1 or later. In earlier versions of Manager, the file will open but it is empty.

Configurations saved onto the PC in this way can be reopened using the  icon or the **File > Offline > Open File** command. If the file has been encrypted, you must enter the password.

When Manager is running in Server Edition mode, the Save command operates differently. Multiple files are saved, one `.cfg` file for each server in the network plus a single `.cfi` file for the whole network.

The `.cfi` file can be used with the **File > Offline > Open File Set** command to open the whole set of files in a single action.

**Related links**

[File Menu](#) on page 49



## File > Change Working Directory

These settings allow you to change the default locations where Manager looks for and saves files.

These fields set the default location where Manager will look for and save files.

Directory	Description
<b>Working Directory (.cfg files)</b>	<p>Sets the directory into which Manager saves <code>.cfg</code> files. By default this is the Manager application's program directory.</p> <p> <b>Note:</b></p> <p>The default folder for Manager <code>.cfg</code> files is <code>C:\Program Files (x86)\Avaya\IP Office\Manager</code>. The file is saved to the user's profile folder at <code>C:\Users \&lt;user_name&gt;\AppData\Local\VirtualStore\Program Files (x86)\Avaya\IP Office\Manager</code>. You must turn on Show hidden files to access this folder. Alternatively, you can set the working directory to an alternate location.</p>

*Table continues...*

Directory	Description
<b>Binary Directory (.bin files)</b>	<p>Sets the directory in which the Manager upgrade wizard, HTTP, TFTP and BOOTP functions look for firmware files requested by phones and other hardware components. That includes .bin file, .scr files and .txt files. By default this is the Manager application's program directory.</p> <p> <b>Tip:</b></p> <p>In the Upgrade Wizard, right-clicking and selecting <b>Change Directory</b> also changes this setting.</p> <p> <b>Warning:</b></p> <p>Historically, by default the <b>Working Directory</b> and <b>Binary Directory</b> are the same. This is deprecated as it potentially allows remote TFTP/HTTP file access to the folder containing copies of configuration files. Therefore it is recommended that either of the folders is changed to an alternate location.</p>
<b>Known Units File</b>	<p>Sets the file and directory into which Manager can record details of the systems it has discovered. Once a file location has been specified, a Known Units button becomes available on the discovery menu used for loading system configuration. Pressing that button displays the known units file as a list from which the required system can be selected. It also allows sorting of the list and records to be removed.</p>

#### Related links

[File Menu](#) on page 49

## File > Preferences

This command displays a window for configuring various aspects of Manager's operation. The window is divided into a number of tabs.

#### Related links

[File Menu](#) on page 49

[File > Preferences > Preferences](#) on page 53

[File > Preferences > Directories](#) on page 56

[File > Preferences > Discovery](#) on page 57

[File > Preferences > Visual Preferences](#) on page 58

[File > Preferences > Security](#) on page 59

[File > Preferences > Validation](#) on page 62

## File > Preferences > Preferences



This tab is accessed through **File | Preferences** and then selecting the **Preferences** tab.

Setting	Description
<b>Edit Services Base TCP Port:</b>	Default = Off This field shows or hides the base communication port settings.
<b>Service Base TCP Port</b>	Default = 50804. Access to the configuration and security settings on a system requires Manager to send its requests to specific ports. This setting allows the TCP Base Port used by Manager to be set to match the TCP Base Port setting of the system. The system's TCP Base Port is set through its security settings.
<b>Service Base HTTP Port</b>	Default = 80. Access to the HTTP server on a system requires Manager to send its requests to specific ports. This setting allows the HTTP Base Port used by Manager to be set to match the HTTP Base Port setting of the system. The system's HTTP Base Port is set through its security settings.
<b>Enable Time Server</b>	Default = On. This setting allows Manager to respond to RFC868 Time requests from systems. It will provide the system with both the UTC time value and the local time value of the PC on which it is running.
<b>Enable BootP and TFTP Servers</b>	Default = Off. This setting allows Manager to respond to BOOTP request from systems for which it also has a matching BOOTP record. It also allows Manager to respond to TFTP requests for files.
<b>Auto Connect on start up</b>	Default = On If on, when Manager is started it will automatically launch the <b>Select IP Office</b> menu and display any discovered systems. If only one system is discovered, Manager will automatically display the login request for that system or load its configuration if the security settings are default.
<b>Set Simplified View as default</b>	Default = Off If on, the Manager will start in simplified view mode if no configuration is loaded.
<b>Default to Standard Mode</b>	Default = Off If on, when a configuration from a new or defaulted system running in Basic mode is loaded, Manager will automatically convert the configuration to Standard mode. Sending the configuration back to the system will restart it in Standard mode. Only select this option if the only systems you expect to install are Standard systems.  This setting does not affect existing systems with non-default configurations.

*Table continues...*

Setting	Description
<b>Use Remote Access</b>	<p>Default = Off.</p> <p>If selected, access to all the configurations of a multi-site network is allowed via remote access to the primary server on the multi-site network. When selected, an additional <b>Use Remote Access</b> check box option is displayed on the Select IP Office menu when the <b>Open with Server Edition Manager</b> check box option is selected or if Manager is already running in Server Edition mode.</p> <p> <b>Note:</b></p> <p>To enable remote access, you must first configure an SSL VPN service between each Server Edition system and the Avaya VPN Gateway (AVG). For information, see <i>Deploying Avaya IP Office™ Platform SSL VPN Services</i>.</p>
<b>Consolidate Solution to Primary Settings</b>	<p>This setting is used by Manager when in Server Edition mode.</p> <p>If <b>Consolidate Network to Primary Settings</b> is selected:</p> <ul style="list-style-type: none"> <li>• Entry and administration of consolidated records is performed only at the solution level except for the <b>Emergency ARS</b> and <b>Fallback System</b> field settings of location records.</li> <li>• Those records are then automatically replicated in the configurations of all the systems in the solution but, except for locations, are still only visible and editable at the solution level.</li> <li>• When the configurations are loaded or when this setting is changed to become selected, if any inconsistency between records are found, a <b>Consolidation Report</b> is displayed. This report allows selection of whether to update the system to match the primary or to update the primary to match.</li> </ul> <p>If <b>Consolidate Network to Primary Settings</b> is not selected:</p> <ul style="list-style-type: none"> <li>• Entry and administration of consolidated records can be performed at both the solution and individual system levels.</li> <li>• Records entered and edited at the solution level are automatically replicated in the configurations of all the systems in the solution. Each record displays a label on the record indicating that it is a record that is shared across the solution.</li> <li>• If a shared record is edited at the individual system level, that copy of the record is no longer shared with the other systems. It will not be updated by any changes to the solution level version of the same record.</li> <li>• No consolidation checking for inconsistencies is done when the configurations are loaded.</li> </ul>

*Table continues...*

Setting	Description
<b>SE Central Access</b>	<p>Default = Off. Applies to Server Edition systems only.</p> <p>If On, all Server Edition systems in the network obtain their configuration data from a central location on the Primary Server. As a result, the display of configuration changes is delayed until a synchronization process runs. The synchronization process runs every 40 seconds. If the configuration change requires a system restart, a refreshed configuration display is delayed until 40 seconds after system restart.</p> <p>This setting can be used to drive configuration changes into expansion systems when the expansion systems are not reachable through Manager and the only accessible system is the Primary Server.</p> <p> <b>Important:</b></p> <p>When adding a new system to the solution, if the Manager setting <b>File &gt; Preferences &gt; Preferences &gt; SE Central Access</b> is set to <b>On</b>, an IP Office Line is not configured from the new system to the Server Edition Primary Server. The status of the new system is <b>Offline</b>. You must configure an IP Office Line from the new system to the Server Edition Primary Server.</p> <p> <b>Note:</b></p> <p>When <b>SE Central Access</b> is set to <b>On</b>, you cannot open configurations with a release number of 9.0.x or earlier. To open older configurations, set <b>SE Central Access</b> to <b>Off</b>.</p> <p>When Manager is in Server Edition mode and <b>SE Central Access</b> is set to <b>On</b>, the following <b>File &gt; Advanced</b> menu options are not available:</p> <ul style="list-style-type: none"> <li>• <b>System Shutdown</b></li> <li>• <b>Memory Card Command</b></li> </ul> <p>In addition to the above, when Manager is in Server Edition mode and <b>SE Central Access</b> is set to <b>On</b> and no configuration is open, the following <b>File &gt; Advanced</b> menu options are greyed out:</p> <ul style="list-style-type: none"> <li>• <b>Erase Configuration (Default)</b></li> <li>• <b>Reboot</b></li> <li>• <b>Erase Security Settings (Default)</b></li> </ul>
<b>SE Central Access Port</b>	<p>Default = 7070.</p> <p>When <b>SE Central Access</b> is set to On, the port used for routing HTTPS requests for configuration synchronization.</p>

### Related links



[File > Preferences](#) on page 53

## File > Preferences > Directories

These settings allow you to change the default locations where Manager looks for and saves files.



These fields set the default location where Manager will look for and save files.

Directory	Description
<b>Working Directory (.cfg files)</b>	<p>Sets the directory into which Manager saves .cfg files. By default this is the Manager application's program directory.</p> <p> <b>Note:</b></p> <p>The default folder for Manager .cfg files is C:\Program Files (x86)\Avaya\IP Office\Manager. The file is saved to the user's profile folder at C:\Users \&lt;user_name&gt;\AppData\Local\VirtualStore\Program Files (x86)\Avaya\IP Office\Manager. You must turn on Show hidden files to access this folder. Alternatively, you can set the working directory to an alternate location.</p>
<b>Binary Directory (.bin files)</b>	<p>Sets the directory in which the Manager upgrade wizard, HTTP, TFTP and BOOTP functions look for firmware files requested by phones and other hardware components. That includes .bin file, .scr files and .txt files. By default this is the Manager application's program directory.</p> <p> <b>Tip:</b></p> <p>In the Upgrade Wizard, right-clicking and selecting <b>Change Directory</b> also changes this setting.</p> <p> <b>Warning:</b></p> <p>Historically, by default the <b>Working Directory</b> and <b>Binary Directory</b> are the same. This is deprecated as it potentially allows remote TFTP/HTTP file access to the folder containing copies of configuration files. Therefore it is recommended that either of the folders is changed to an alternate location.</p>
<b>Known Units File</b>	<p>Sets the file and directory into which Manager can record details of the systems it has discovered. Once a file location has been specified, a Known Units button becomes available on the discovery menu used for loading system configuration. Pressing that button displays the known units file as a list from which the required system can be selected. It also allows sorting of the list and records to be removed.</p>

### Related links

[File > Preferences](#) on page 53

## File > Preferences > Discovery

These settings affect the **Select IP Office** menu used by Manager to discovery systems.

Setting	Description
<b>TCP and HTTP Discovery</b>	<p>Default = On.</p> <p>This setting controls whether Manager uses TCP to discover systems. The addresses used for TCP discovery are set through the IP Search Criteria field below.</p>

*Table continues...*

Setting	Description
<b>NIC IP/NIC Subnet</b>	This area is for information only. It shows the IP address settings of the LAN network interface cards (NIC) in the PC running Manager. Double-click on a particular NIC to add the address range it is part of to the IP Search Criteria. Note that if the address of any of the Manager PC's NIC cards is changed, the Manager application should be closed and restarted.
<b>IP Search Criteria</b>	This section is used to enter TCP addresses to be used for the TCP discovery process. Individual addresses can be entered separated by semi-colons, for example 135.164.180.170; 135.164.180.175. Address ranges can be specified using dashes, for example 135.64.180.170 - 135.64.180.175.
<b>UDP Discovery</b>	Default = On This settings controls whether Manager uses UDP to discover systems.
<b>Enter Broadcast IP Address</b>	Default = 255.255.255.255 The broadcast IP address range that Manager should used during UDP discovery. Since UDP broadcast is not routable, it will not locate systems that are on different subnets from the Manager PC unless a specific address is entered.
<b>Use DNS</b>	Selecting this option allows Manager to use DNS name (or IP address) lookup to locate a system. Note that this overrides the use of the TCP Discovery and UDP Discovery options above. This option requires the system IP address to be assigned as a name on the users DNS server. When selected, the <b>Unit/Discovery Address</b> field on the Select IP Office window is replaced by a <b>Enter Unit DNS Name or IP Address</b> field.
<b>SCN Discovery</b>	If enabled, when discovering systems, the list of discovered systems will group systems in the same Small Community Network and allow them to be loaded as a single configuration. At least one of the systems in the Small Community Network must be running Release 6.0 or higher software. See <a href="#">Configuring Small Community Networking</a> on page 786. This does not override the need for each system in the Small Community Network to also be reachable by the <b>TCP Discovery</b> and or <b>UDP Discovery</b> settings above and accessible by the router settings at the Manager location.

**Related links**

[File > Preferences](#) on page 53

**File > Preferences > Visual Preferences**

Setting	Description
<b>Icon size</b>	Sets the size for the icons in the navigation pane between <b>Small</b> , <b>Medium</b> or <b>Large</b> .
<b>Multiline Tabs</b>	Default = Off. In the details pane, for record types with more than two tabs, Manager can either use  buttons to scroll the tabs horizontally or arrange the tabs into multiple rows. This setting allows selection of which method Manager uses.

**Related links**

[File > Preferences](#) on page 53

## File > Preferences > Security

### Additional configuration information

For additional configuration information, see [Security Administration](#) on page 158. Also see *Avaya IP Office™ Platform Security Guidelines*.

### Configuration settings

Controls the various security settings of Manager. To control the security settings of the system, see the information on Security mode.

All settings, except **Secure Communications**, can only be changed when a configuration has been opened using a user name and password with Administrator rights or security administration rights.

Setting	Description
<b>Request Login on Save</b>	<p>Default = On</p> <p>By default a valid user name and password is required to receive a configuration from a system and also to send that same configuration back to the system. Deselecting this setting allows Manager to send the configuration back without having to reenter user name and password details. This does not apply to a configuration that has been saved on PC and then reopened. This setting can only be changed when a configuration has been opened using a user name and password with Administrator rights or security administration rights.</p>
<b>Close Configuration/ Security Settings After Send</b>	<p>Default = On.</p> <p>When selected, the open configuration file or security settings are closed after being sent back to the system. This is the normal default. This setting does not affect multi-site network modes of Manager which always close the configuration after saving.</p> <p>Before disabling this setting, you should recall that the configuration held by a running system can be changed by actions other than Manager, for example changes made by users through their phone. Keeping a configuration open in Manager for longer than necessary increases the chances that that copy of the configuration differs from the current configuration of the running system and will overwrite those changes when sent back to the system.</p>
<b>Save Configuration File After Load</b>	<p>Default = Off.</p> <p>When selected, a copy of the configuration is saved to Manager's working directory. The file is named using the system name and the suffix <b>.cfg</b>. This setting can only be changed when a configuration has been opened using a user name and password with Administrator rights or security administration rights.</p>
<b>Backup Files on Send</b>	<p>Default = Off.</p> <p>If selected, whenever a copy of a configuration is sent to a system, a backup copy is saved in Manager's working directory. The file is saved using the system name, date and a version number followed by the <b>Backup File Extension</b> as set below. This setting can only be changed when a configuration has been opened using a user name and password with Administrator rights or security administration rights.</p>

*Table continues...*

Setting	Description
<b>Backup File Extension</b>	<p>Default = .BAK</p> <p>Sets the file extension to use for backup copies of system configurations generated by the Backup Files on Send option above.</p>
<b>Number of Backup Files to keep</b>	<p>Default = Unlimited.</p> <p>This option allows the number of backup files kept for each system to be limited. If set to a value other than <b>Unlimited</b>, when that limit would be exceeded, the file with the oldest backup file is deleted.</p>
<b>Enable Application Idle Timer ( mins)</b>	<p>Default = On.</p> <p>When enabled, no keyboard or mouse activity for 10 minutes will cause the Manager to grey out the application and re-request the current service user password. This setting can only be changed when a configuration has been opened using a user name and password with Administrator rights or security administration rights.</p>
<b>Secure Communications</b>	<p>Default = On</p> <p>When selected, any service communication from Manager to the system uses the TLS protocol. This will use the ports set for secure configuration and secure security access. It also requires the configuration and or security service within the system's security configuration settings to have been set to support secure access. Depending on the level of that secure access selected, it may be necessary for the <b>Manager Certificate Checks</b> below to be configured to match those expected by the system for configuration and or security service.</p> <ul style="list-style-type: none"> <li>• When <b>Secure Communications</b> is set to <b>On</b>, a  padlock icon is displayed at all times in the lower right Manager status field.</li> <li>• For Server Edition systems, Manager will always attempt to use secure communications regardless of the <b>Secure Communications</b> setting.</li> <li>• If no response to the use of secure communication is received after 5 seconds, Manager will offer to fallback to using unsecured communications.</li> </ul>
<b>Manager Certificate Checks</b>	<p>When the Secure Communications option above is used, Manager will process and check the certificate received from the system. This setting can only be changed when a configuration has been opened using a user name and password with Administrator rights or security administration rights. The options are:</p> <ul style="list-style-type: none"> <li>• <b>Low</b>: Any certificate sent by the system is accepted.</li> <li>• <b>Medium</b>: Any certificate sent by the system is accepted if it has previously been previously saved in the Windows' certificate store. If the certificate has not been previously saved, the user has the option to review and either accept or reject the certificate.</li> <li>• <b>High</b>: Any certificate sent by the system is accepted if it has previously been previously saved in the Windows' certificate store. Any other certificate cause a log in failure.</li> </ul>

*Table continues...*

Setting	Description
<b>Certificate Offered to IP Office</b>	<p>Default = none Specifies the certificate used to identify Manager when the Secure Communications option is used and the system requests a certificate. Use the <b>Set</b> button to change the selected certificate. Any certificate selected must have an associated private key held within the store:</p> <ul style="list-style-type: none"> <li>• Select from Current User certificate store - Display certificates currently in the currently logged-in user store.</li> <li>• Select from Local Machine certificate store.</li> <li>• Remove Selection – do not offer a Manager certificate.</li> </ul>

## Security – Registry Settings

### Warning:

Avaya accept no liability for any issues arising from the editing of a PC's registry settings. If you are in any doubt about how to perform this process you should not proceed. It is your responsibility to ensure that the registry is correctly backed up before any changes are made.

### Note:

Before manually editing any registry entry, the following Microsoft support articles should be read:

- <http://support.microsoft.com/kb/256986>
- [http://www.microsoft.com/resources/documentation/windows/xp/all/proddocs/en-us/regedit\\_permit\\_key.mspx](http://www.microsoft.com/resources/documentation/windows/xp/all/proddocs/en-us/regedit_permit_key.mspx)

Manager stores its security preferences in the Windows Registry. The following key affects manager security operation; its values may only be changed by a configuration or security administrator:

```
HKEY_CURRENT_USER\Software\Avaya\IP400\Manager\Security\
```

In order to prevent circumvention by manual editing of the Windows Registry, Regedt32.exe, the native registry editor, allows an operator user (with Full Control permissions) to edit permissions on a per key basis.

To prevent a user from manually editing the security preferences, the HKEY\_USERS\User GUID\Software\Avaya\IP400\Manager\Security key permission should be set to 'Read' only for that user. Ensure that all child object permissions are replaced as well by using the 'Advanced' button.

To allow the security policy of all local PC users to be fixed, a set of values in the key HKEY\_CURRENT\_USER\Software\Avaya\IP400\Manager\Security\ may be created. This is tested and used in preference to any value found under HKEY\_CURRENT\_USER\Software\Avaya\IP400\Manager\Security\.

This key is not created by the manager application.

## Related links

[File > Preferences](#) on page 53

## File > Preferences > Validation

By default Manager validates the whole configuration when it is loaded and individual fields whenever they are edited. This tab allows selection of when automatic validation should be applied to configuration files loaded into Manager.

Setting	Description
<b>Validate configuration on open</b>	Automatically validate configuration files when they are opened in Manager.
<b>Validate configuration on edit</b>	Validate the whole configuration when <b>OK</b> is clicked after editing a record. For large configurations, disabling this option removes the delay caused by validating the configuration after every edit.
<b>Prompt for configuration validation on save or send</b>	If selected, when saving or sending a configuration, a prompt is displayed asking whether the configuration should be validated. If validation is selected and error are found, the send or save process is canceled. This option is disabled if Validate configuration on edit is selected.

### Related links

[File > Preferences](#) on page 53

---

## File > Offline

### Related links

[File Menu](#) on page 49

[File > Offline > Create New Config](#) on page 62

[File > Offline > Open File](#) on page 62

[File > Offline > Open File Set](#) on page 63

[File > Offline > Send Config](#) on page 63

[File > Offline > Receive Config](#) on page 63

## File > Offline > Create New Config

Used to create an offline configuration.

This command starts a dialog that allows you to create a default offline configuration by specifying the system locales, the type of control unit and expansion modules and the trunk cards fitted. The same action is performed by the  icon in the Main Toolbar.

### Related links

[File > Offline](#) on page 62

## File > Offline > Open File

This command allows a configuration file stored on PC to be opened in Manager.

### Related links

[File > Offline](#) on page 62

## File > Offline > Open File Set

This command is only available when manager is running in Server Edition mode. It can be used to load a set of files previously saved offline using the **File > Save Configuration As** command.

When selected, browse to the location of the saved `.cfi` file and associated `.cfg` files and select the `.cfi` file.

### Related links

[File > Offline](#) on page 62

## File > Offline > Send Config

This command is used to send an offline configuration to a system.

### Warning:

After this command is completed, the system is rebooted. This will end all calls and services in progress.

After sending the configuration, you should receive the configuration back from the system and note any new validation errors shown by Manager. For example, if using Embedded Voicemail, some sets of prompt languages may need to be updated to match the new configurations locale setting using the Add/Display VM Locales option.

### Related links

[File > Offline](#) on page 62

## File > Offline > Receive Config

This command displays the **Select IP Office** menu used to receive a systems configuration settings.

Once the configuration has been received, you are prompted to save it on the PC.

### Related links

[File > Offline](#) on page 62

---

## File > Advanced

### Related links

[File Menu](#) on page 49

[File > Advanced > Erase Configuration](#) on page 64

[File > Advanced > Reboot](#) on page 64

[File > Advanced > System Shutdown](#) on page 65

[File > Advanced > Upgrade](#) on page 66

[File > Advanced > Change Mode](#) on page 68

[File > Advanced > Audit Trail](#) on page 69

[File > Advanced > Security Settings](#) on page 70

[File > Advanced > Erase Security Settings \(Default\)](#) on page 70

[File > Advanced > Embedded File Management](#) on page 70

[File > Advanced > Format IP Office SD Card](#) on page 71

[File > Advanced > Recreate IP Office SD Card](#) on page 72

[File > Advanced > Memory Card Command](#) on page 73

[File > Advanced > Launch Voicemail Pro](#) on page 74

[File > Advanced > System Status](#) on page 74

[File > Advanced > LVM Greeting Utility](#) on page 74

[File > Advanced > Generate WebLM ID](#) on page 75

[File > Advanced > Initial Configuration](#) on page 75

[File > Advanced > Add/Display VM Locals](#) on page 79

## File > Advanced > Erase Configuration

This command returns the configuration settings of a system back to their default values. It does not affect the system's security settings or audit trail record.

When this command is used, the **Select IP Office** menu is displayed. Once a system is selected, a valid configuration user name and password are required to complete the action.

IP500 V2 systems using **IP Office A-Law** or **IP Office U-Law** System SD cards will default to Quick mode. Loading the configuration will switch Manager to simplified view. To change the system back to operating in Standard mode, use either of the following methods:

- **Change Mode**

This will change the operating mode of the system and create a default configuration appropriate to that mode.

### Related links

[File > Advanced](#) on page 63

## File > Advanced > Reboot

When this command is used, the **Select IP Office** window is displayed. Once a system is selected, a valid user name and password are required. The type of reboot can then be selected in the Reboot window.

When the reboot occurs can be selected as follows:

- **Immediate** Send the configuration and then reboot the system.
- **When Free** Send the configuration and reboot the system when there are no calls in progress. This mode can be combined with the **Call Barring** options.
- **Timed** The same as When Free but waits for a specific time after which it then wait for there to be no calls in progress. The time is specified by the **Reboot Time**. This mode can be combined with the **Call Barring** options.

**Reboot Time** This setting is used when the reboot mode **Timed** is selected. It sets the time for the reboot. If the time is after midnight, the system's normal daily backup is canceled.



**Call Barring** These settings can be used when the reboot mode **When Free** is selected. They bar the sending or receiving of any new calls.

#### Related links

[File > Advanced](#) on page 63

## File > Advanced > System Shutdown

This command can be used to shutdown systems. The shut down can be either indefinite or for a set period of time after which the system will reboot. For Linux based telephone systems, the shutdown command is applied to the telephony service on the server and not to the whole sever. In that case, if the system is shutdown indefinitely, it can be restarted using the server's web control pages to either restart the service or to restart the whole server.

#### **Warning:**

A shutdown must always be used to switch off the system. Simply removing the power cord or switching off the power input may cause the loss of configuration data.

This is not a polite shutdown, any user calls and services in operation will be stopped. Once shutdown, the system cannot be used to make or receive any calls until restarted.

The shutdown process takes up to a minute to complete. When shutting down a system with a Unified Communications Module installed, the shutdown can take up to 3 minutes while the card safely closes all open files and closes down its operating system. During this period the module's LED 1 remains green.

When shutdown, the LEDs shown on the system are as follows. Do not remove power from the system or remove any of the memory cards until the system is in this state:

- LED1 on each IP500 base card installed will also flash red rapidly plus LED 9 if a trunk daughter card is fitted to the base card.
- The CPU LED on the rear of the system will flash red rapidly.
- The System SD and Optional SD memory card LEDs on the rear of the system are extinguished.

To restart a system when shutdown indefinitely, or to restart a system before the timed restart, switch power to the system off and on again.

Once you have selected the system from the Select IP Office window, the System Shutdown Mode window opens. Select the type of shutdown required:

- If a **Timed** shutdown is selected, the system will reboot after the set time has elapsed.
- If **Indefinite** is used, the system can only be restarted by having its power switched off and then on again. For Linux based telephone systems, the telephony service must be restarted through the server's web control pages.

#### Related links

[File > Advanced](#) on page 63

## File > Advanced > Upgrade

### Note:

This command is not used with Linux based systems. Linux systems are updated through the server's webcontrol menus.

This command starts the **Upgrade Wizard** tool. The **Upgrade Wizard** is used to compare the software level of the control unit and modules within systems against the software level of the .bin binary files Manager has available. The Upgrade Wizard can then be used to select which units to upgrade.

### Warning:

- Incorrect use of the upgrade command can halt system operation and render units in the system unusable. You must refer to the Technical Bulletins for a specific release for full details of performing software upgrades to that release. There may be additional steps required such as defaulting the security settings.
- Performing any other actions on a system during an upgrade or closing the upgrade wizard and Manager during an upgrade may render systems unusable.
- During an upgrade the system may restrict calls and services. It will reboot and disconnect all current calls and services.
- The **Validate** option must remain selected wherever possible. Use of unvalidated upgrades is subject to a number of conditions outlined in the IP Office Installation Manual and Technical Bulletins.

The list area shows details of systems found by the Upgrade Wizard and the software currently held by those systems. The check boxes are used to select which units should be upgraded. Upgrading will require entry of a valid name and password for the selected system.

Column	Description
<b>Name</b>	The name of the system as set in its configuration ( <b>System   System   Name</b> ) .
<b>IP Address</b>	The IP address of the system.
<b>Type</b>	The type of system and the names of the various firmware files used by external expansion systems supported by the system type.
<b>Version</b>	Details the current software each unit in the systems is running.
<b>Edition</b>	Indicates the operation mode of the system.
<b>Licensed</b>	Indicates the highest value software upgrade license present in the system's configuration. The IP Office Release that is supported by that license is also indicated in brackets.

*Table continues...*

Column	Description
<b>Required License</b>	<p>Indicates the software upgrade license required for the current level of software the system is running. The IP Office Release that is supported by that license is also indicated in brackets.</p> <p>It does not refer to the software upgrade license required for the level of software which is available for upgrade. The system must include a license for the specific level of software it is required to run.</p> <p>For IP500 V2 systems, a value of 255 indicates that the control unit is still in its initial 90 days where it can be upgraded to a higher level without requiring an upgrade license.</p>
<b>Available</b>	<p>Shows the version of the matching firmware files that Manager has available (a – indicates no file available) in its current working directory. Upgrading to a release higher than that supported by the current Licensed level will leave the system unable to support any functions until the appropriate upgrade license is added to the system configuration.</p>

The Upgrade Wizard includes a number of check boxes that can be used to include other actions as part of the upgrade process:

- **Validate**
  - The Validate option should remain selected wherever possible. When selected, the upgrade process is divided as follows: transfer new software, confirm transfer, delete old software, restart with new software. If **Validate** is not selected, the old software is deleted before the new software is transferred.
- **Backup System Files**
  - For any IP500 V2 systems being upgraded, the **Backup system files** option will cause the system to backup its memory card files as part of the upgrade.
- **Upload System File**
  - For any IP500 V2 system being upgraded, the **Upload system files** option will upload various files:
    - It copies the binary files for the system control unit and possible external expansion modules.
    - It copies the firmware files used by phones supported by the system.
    - It copies the files for Web Manager.
    - For systems configured to run Embedded Voicemail, the Embedded Voicemail prompts for those supported languages set as the system locale, user locales, incoming call route locales and short code locales are upgraded.
- **Restart IP Phones** For Manager 8.1 and higher the Restart IP Phones option can be used. This will cause those phone to load any upgrade phone firmware included in the system upgrade (if using the system's memory card as their firmware file source).

#### Related links

[File > Advanced](#) on page 63

## Searching for Systems

The default address used by the Upgrade Wizard is the address shown in the Manager title bar, which is selected through **File | Preferences**. If the unit required is not found, the address used can be changed.

### Procedure

1. Enter or select the required address in the **Unit/Broadcast Address** field.
2. Click **Refresh** to perform a new search.

## Changing the .bin File Directory

The directory in which the Upgrade Wizard looks for .bin files is set through Manager's Binary Directory setting. This can be changed using **Files | Change Working Directory** or **File | Preferences | Directories**.

Use this procedure to change it directly from the Upgrade Wizard.

### Procedure

1. Right-click on the list area.
2. Select **Select Directory**.
3. Browse to and highlight the folder containing the .bin files. Click **OK**.
4. The list in the **Available** column will be updated to show the .bin files in the selected directory that match units or modules listed.

## File > Advanced > Change Mode

This command can be used to change the operating mode of an IP500 V2 system from Basic Edition to either standard IP Office or Server Edition expansion. To convert an existing system to Basic Edition mode, use the default configuration options.

### Important:

Using this command will default the configuration. Therefore ensure that you have a backup copy of the configuration before using this command in case it is necessary to return to the previous mode.

Do not use this command if the **Default to Standard Mode** option is enabled in the IP Office Manager preferences. Disable the option first.

Note that if the system includes components not supported by the mode to which it is switched, they will not work in the new mode. For example, ETR cards which are only supported in Basic Edition.

In order to use this command, the system security settings must be at their default settings. The current setting can be defaulted using the **Erase Security Settings (Default)** command.

After a mode change, the system restarts. If the system does not restart, the most likely cause is that the systems security settings were not at their default settings.

## Related links

[File > Advanced](#) on page 63

## File > Advanced > Audit Trail

The audit trail lists the last 16 actions performed on the system from which the configuration loaded into Manager was received. It includes actions by service users such as sending a configuration back, reboots, upgrades and defaulting the system.

Audit trail events can be output to a Syslog server through the system's **System | System Events** settings.

The last failed action is always recorded and shown in red. It is kept even if there have been 16 subsequent successful actions.

The Audit Trail is part of the system configuration file received from the system. If the configuration is kept open between send and reboot operations (ie. if Close Configuration/Security Setting After Send is not selected), the Audit Trail will not show details of those operations. It will only show details of those operations if the configuration is closed and then a new copy of the configuration is received from the system.

### Audit Details

When a specific access event is selected from the list, the following information is shown in the Audit Details section:

- The **Security User** shows the service user name used for the access action.
- The **Date and Time of Access** indicate the local system time when the recorded event occurred.
- The **PC Login** is the computer name of the PC used for the access.
- The **PC IP Address** and **PC MAC Address** are the IP address and MAC address of the PC used for access.
- The **Access Type** details the type of action that was performed.
- The **Outcome** shows the system's response to the access. The outcome **Success (Warning)** refers to the sending of a configuration that contains fields marked as errors or warnings by Manager's validation function. **Success (Clean)** refers to the sending of a configuration that does not contain any validation errors or warnings.
- The **IP Office Firmware** indicates the IP Office Release version.

### Items Changed

The Items Changed area summarizes the changes contained in a sent configuration. Where changes to a single record of a particular type are made, the Item Name field lists the individual record changed. Where changes are made to several records of the same type, the Item Name field displays Multiple items.

## Related links

[File > Advanced](#) on page 63

## File > Advanced > Security Settings

This command is used to switch the Manager application to security mode. In that mode, Manager is used to edit the security settings of a system.

### Related links

[File > Advanced](#) on page 63

## File > Advanced > Erase Security Settings (Default)

This command returns the security settings of a system back to their default values. This action does not affect the system's configuration or audit trail record. When this command is used, the **Select IP Office** menu is displayed. Once a system is selected, a valid security user name and password are required to complete the action.

The system's security settings are returned to their defaults as indicated in the Security Mode chapter.

Note that any security certificates stored and being used by the system are deleted. Any services currently using those certificates are disconnected and disabled until the appropriate certificates are added back to the system's security configuration. That includes SSL VPN connections being used to perform system maintenance.

The name and password used for this command are those required for security configuration access which are different from those used for normal configuration access.

For IP500 V2 control units, if the security settings cannot be defaulted using this command, they can be defaulted using a DTE cable connection to the system. Refer to the IP Office Installation manual for details.

### **Warning:**

Service Disruption.

Whilst defaulting the security settings does not require a system reboot, it may cause service disruption for several minutes while the system generates a new default security certificate.

### Related links

[File > Advanced](#) on page 63

## File > Advanced > Embedded File Management

For control units with a memory card installed, the contents of the card can be viewed using Manager. This view can also be used to add and remove files from the card. This may be useful when the memory card is being used to store Music on Hold or IP phone firmware files.

- For non-Linux systems, the folders accessed using embedded file management are those on the SD cards installed in the control unit.
- For Linux based systems, the folder path displays as `disk` in the embedded file manager. That path maps onto `/opt/ipoffice` on the server.

**Related links**

[File > Advanced](#) on page 63

**File > Advanced > Format IP Office SD Card**

This command allows suitable SD cards to be formatted by the Manager PC. The system supports SD cards with the following format: SDHC minimum 4GB FAT32 format (Single partition, SDHC, class2+, FAT32, SPI & SD bus). Non-Avaya supplied cards of the same format can be used a system's **Optional SD** slot for additional actions such as backup.

** Warning:**

- Do not re-purpose a Enterprise Branch SD card for use with any other IP Office mode. Doing so may damage the SD card and make it unusable for your Enterprise Branch system.
- **All File Will Be Erased** Note that this action will erase any existing files and folders on the card. If the requirement is just to update the card, use Recreate IP Office SD Card without reformatting. Once a card has been formatted, the folders and files required for operation can be loaded onto the card from the Manager PC using the Recreate IP Office SD Card command.
- Avaya supplied SD cards should not be formatted using any other method than the format commands within Manager and System Status Application. Formatting the cards using any other method will remove the feature key used for system licensing from the card.

**Related links**

[File > Advanced](#) on page 63

[Formatting the SD card](#) on page 71

**Formatting the SD card****Procedure**

1. Insert the SD card into a reader slot on the Manager computer.
2. Using Manager, select **File | Advanced | Format IP Office SD Card**.
3. Select the type of card.

This selection just sets the card label shown when viewing the card details. It does not affect the actual formatting. Select the label that matches the file set you will be placing on the card.

- **IP Office A-Law** A system fitted with this type of card will default to A-Law telephony.
- **IP Office U-Law** A system fitted with this type of card will default to U-Law telephony.
- **Enterprise Branch** Use this option for an SD card intended to be used with an IP Office system running in Enterprise Branch Mode. There is a separate SD card for Enterprise Branch. The Enterprise Branch SD card can only be used for Enterprise Branch operation and cannot be used to change modes to IP Office. You also cannot use or change an IP Office SD card for use with an Enterprise Branch system.

 **Warning:**

Do not re-purpose a Enerprise Branch card for use with any other IP Office mode. Doing so may damage the SD card and make it unusable for your Enterprise Branch system.

4. Browse to the card location and click **OK**.
5. The status bar at the bottom of Manager will display the progress of the formatting process.
6. When the formatting is complete, you can use the Recreate IP Office SD Card command to load the system folders and files onto the card from the Manager PC.

**Related links**

[File > Advanced > Format IP Office SD Card](#) on page 71

## File > Advanced > Recreate IP Office SD Card

This command can be used with the System SD cards used by IP500 V2 control units. It allows Manager to copy all the files and folders used by a system when starting onto the card that has been place into the card slot of the PC running Manager. It updates the card with the version of those files installed with the Manager application. It includes the binary files for the system, external expansion modules and phones. The command also copies all language prompt sets used by Embedded Voicemail.

If the card contains dynamic system files such as SMDR records, they are temporarily backed up by Manager and then restored after the card is recreated. For the card to be used in a system's **System SD** slot the card must be Avaya SD Feature Key card. The card must be correctly formatted, however a reformat of an existing working card is not necessary before using recreate to update the card contents.

The source for the files copied to the SD card are the sub-folders of the **Memory Cards** folder under Manager's Working Directory (normally `C:\Program Files\Avaya\IPOffice\Manager`). However, if the Working Directory is changed to a location without an appropriate set of **Memory Cards** sub-folders, the required set of files will not be copied onto the SD card.

**Related links**

[File > Advanced](#) on page 63

[Recreating the IP Office SD Card](#) on page 72

## Recreating the IP Office SD Card

### About this task

 **Note:**

This process can take up to 20 minutes depending on the PC. Once started, the process should not be interrupted.

Memory cards folder is missing in `IPOAdminLite.exe` installation because of which you will not be able to upgrade system files or Web Manager files using `IPOAdminLite` Manager. Also you will not be able to recreate SD card with `IPOAdminLite.exe` installation.



## Procedure

1. Insert the SD card into a reader slot on the Manager computer.
2. Using Manager, select **File | Advanced | Recreate IP Office SD Card**.
3. Select the type of system for which the card is intended.

This selection will affect how the system operates when defaulted with this card present in its **System SD** card slot.

- **IP Office A-Law** A system fitted with this type of card will default to A-Law telephony.
- **IP Office U-Law** A system fitted with this type of card will default to U-Law telephony.
- **Enterprise Branch** Use this option for an SD card intended to be used with an IP Office system running in Enterprise Branch mode. There is a separate SD card for IP Office. The Enterprise Branch SD card can only be used for IP Office operation and cannot be used to change modes to IP Office. You also cannot use or change an IP Office SD card for use with an Enterprise Branch system.

### **Warning:**

Do not re-purpose a Enterprise Branch SD card for use with any other IP Office mode. Doing so may damage the SD card and make it unusable for your Enterprise Branch system.

4. Browse to the card location and click **OK**.
5. For all systems, these files are necessary if you want to go through the process of on-boarding registration.
6. Manager will start creating folders on the SD card and copying the required files into those folders.
7. Do not remove the card until the process is completed and Manager displays a message that the process has been completed.

## Related links

[File > Advanced > Recreate IP Office SD Card](#) on page 72

## File > Advanced > Memory Card Command

These commands are used with the memory cards installed in IP500 V2 control units.

### Shutdown

This command can be used to shutdown the operation of IP500 V2 unit memory cards.

This action or a system shutdown must be performed before a memory card is removed from the unit. Removing a memory card while the system is running may cause file corruption. Card services can be restarted by either reinserting the card or using the Start Up command.

Shutting down the memory card will disable all services provided by the card including Embedded Voicemail if being used. Features licensed by the memory card will continue to operate for up to 2 hours.

## Start Up

This command can be used to restart operation of an IP500 V2 memory card that has been shut down. >The command will start the **Select IP Office** discovery process for selection of the system.

### Related links

[File > Advanced](#) on page 63

## File > Advanced > Launch Voicemail Pro

If the Voicemail Pro client is installed on the same PC as Manager, this link can be used to launch the Voicemail Pro client. This can also be done by clicking on the  icon in the Manager toolbar.

### Related links

[File > Advanced](#) on page 63

## File > Advanced > System Status

System Status is an application that can be used to monitor and report on the status of a system.

This is a separate application from Manager but if installed on the same PC, it can be started using the **File | Advanced | System Status** link within Manager. Use of the application requires a service user name and password configured on the system for System Status Access within the system's security settings.

### Related links

[File > Advanced](#) on page 63

## File > Advanced > LVM Greeting Utility

This command launches a utility that can be used to convert .wav files to the formats used by Embedded Voicemail (**c11**). The source file must be in the standard format used for all system applications: PCM, 8kHz 16-bit, mono.

The resulting named greeting files can then be transferred to the Embedded Voicemail memory card and selected as auto attendant greetings. That is done using the Recording Name field on the Auto Attendant | Auto Attendant tab. The same named greeting file can be used in several auto attendants.

The utility can be run separately using the file **LVMGreeting.exe** found in the **LVMGreeting** subfolder of the Manager application.

### \* Note:

The LVM Greeting Utility option is not selectable (grayed out) when Voicemail Pro is selected as the system's voicemail type.

### Related links

[File > Advanced](#) on page 63

## File > Advanced > Generate WebLM ID

This menu is only used for Linux based systems. Any system being upgrading from pre-Release 10 ADI licenses must be migrated to PLDS licenses before upgrading. This is done using the files created by the license migration tool. However, that tool assumes that the system will also be the licence host. If instead the system is going to use PLDS license hosted by a WebLM server, the system's web license server host ID is required in addition to the files created by the license migration tool. The Generate WebLM ID tool provides that additional ID.

### To generate the server's Web License Server Host ID:

1. Click **File | Advanced | Generate WebLM ID**. The menu displayed varies depending on whether the server is virtualized or not.
2. Enter the details of the server. For a virtualized server, the UUID can be obtained as follows:
  - Using the command line command: `dmidecode -s system-uuid`
  - From the `uuid.bios` line of the virtual machines `vmx` file.
  - From the VSphere client. See <http://www-01.ibm.com/support/docview.wss?uid=swg21682150>.
3. Click **Generate**.

### Related links

[File > Advanced](#) on page 63

## File > Advanced > Initial Configuration

### \* Note:

The **Initial Configuration** utility changes the security settings. Therefore, the user running the utility must have security read/write rights.

The **Initial Configuration** menu is displayed for all new or fully defaulted IP500 V2 systems. It allows the required operating mode for the system to be selected.

For a system that you want to run in Essential Edition, Preferred Edition or Advanced Edition modes, select **IP Office Standard Mode**.

For an IP500 V2 system to run in Standard Mode, its configuration must include an **Essential Edition** license. A Standard Mode system without this license will not allow any telephony functions.

For a system that is being installed as an expansion server for a Server Edition solution, select **Server Edition Expansion**.

### Server Edition Initial Configuration

On a Standard Mode system, use the Initial Configuration option to convert the existing system configuration into a Server Edition system configuration. It will effectively default the configuration and reload it in Manager in Server Edition mode. Once **Server Edition Expansion** is selected as the **System Type**, the **Initial Configuration** menu is displayed. If **Server Edition Expansion** is selected in that menu, following selection of the various menu options, the system is rebooted as a Expansion System (V2) for a Server Edition network.

For systems being configured for operation in a Server Edition solution, the **Initial Configuration** menu is used to set or confirm a range of settings. The field shown and accessible in the form depend on the selected **System Type**.

After selecting the required menu, click **Save**. The values entered are written into the system configuration and system restarts. The menu is also displayed when creating an offline configuration for a Server Edition system. An existing non-Server Edition system can be converted to a Server Edition configuration, and in turn for Server Edition (Non-Select) or (Select) mode the conversion to Subscription mode can be achieved by rerunning **Initial Configuration** menu. You can select Subscription mode by navigating to **File > Advanced > Initial Configuration**. See Subscription System Details.

Option	Description
<b>System Mode</b>	Indicates the type of server role the system performs. <ul style="list-style-type: none"> <li>• <b>Server Edition- Select</b></li> <li>• <b>Server Edition- Subscription</b></li> </ul>
<b>System Name</b>	A name to identify this system. This is typically used to identify the configuration by the location or customer's company name. Some features such as Gatekeeper require the system to have a name. This field is case sensitive and within any network of systems must be unique. Do not use <, >,  , \0, :, *, ?, . or /.
<b>Retain Configuration Data</b>	This option is shown for IP500 V2 units being converted to become Expansion System (V2)s in a Server Edition solution.  By default <b>Retain Configuration Data</b> option is cleared, the existing configuration of the system is defaulted as per a standard Server Edition expansion system.  Enabling <b>Retain Configuration Data</b> option, the existing configuration is retained. However, some elements of that configuration may be invalid or ignored in a Server Edition solution. It is the installers responsibility to ensure that the final configuration is valid for use in the solution. For more information on IP500 V2 conversion, see <i>Deploying Avaya IP Office™ Platform Server Edition</i> .
<b>Hosted Deployment</b>	The option allows to select when deploying IP Office in a hosted environment. Selecting this option sets HTTP directory to HTTPS. The default is unchecked.
<b>Services Device ID</b>	Set a Device ID for the system. This ID is displayed on the Solution View and System Inventory pages and on the System   System tab in the configuration. The value can be changed using the <b>Device ID</b> field on the System   System Events   Configuration tab. If an SSL VPN is configured, , Avaya recommends that the Device ID match an SSL VPN service Account Name. Each SSL VPN service account name has an associated SSL VPN tunnel IP address. Having the displayed Device ID match an SSL VPN service account name helps identify a particular SSL VPN tunnel IP address to use for remotely managing IP Office.
<b>Locale</b>	This setting sets default telephony and language settings based on the selection. It also sets various external line settings and so must be set correctly to ensure correct operation of the system. See <i>Avaya IP Office™ Platform Locale Settings</i> . For individual users the system settings can be overridden through their own locale setting ( <b>User &gt; User &gt; Locale</b> ).

Table continues...

Option	Description
<b>Default Extension Password</b>	<p>Default = Existing default extension password</p> <p>The field provides you with option to view and edit the existing default extension password. The default extension password is set up during IP Office installation either by the administrator or is randomly generated by the system. The system generated random password is of 10 digits. Use the Eye icon to see the existing default password. The password must be between 9 to 13 digits.</p>
<b>Confirm Default Extension Password</b>	If you are changing the default extension password, type the new default password.
<b>LAN Interface</b>	This IP Address, IP Mask, Gateway and DHCP Mode settings can be set for the systems two LANs, LAN1 and LAN2. These radio buttons are used to switch between displaying the LAN1 details or the LAN2 details.
<b>IP Address</b>	<p>LAN1 Default = 192.168.42.1. LAN2 Default = 192.168.43.1.</p> <p>This is the IP address of the Control Unit on LAN1. If the control unit is also acting as a DHCP server on the LAN, this address is the starting address for the DHCP address range.</p>
<b>IP Mask</b>	Default = 255.255.255.0. This is the IP subnet mask used with the IP address.
<b>Gateway</b>	The address of the default gateway for routing traffic not in the same subnet address range of the <b>IP Address/IP Mask</b> set above. A default IP Route for this address is added to the systems configuration.
<b>DHCP Mode:</b>	<p>Default = Server.</p> <p>This controls the control unit's DHCP mode for the LAN. When doing DHCP:</p> <ul style="list-style-type: none"> <li>• LAN devices are allocated addresses from the bottom of the available address range upwards.</li> <li>• Dial In users are allocated addresses from the top of the available range downwards.</li> <li>• If the control unit is acting as a DHCP server on LAN1 and LAN2, Dial in users are allocated their address from the LAN1 pool of addresses first.</li> <li>• <b>Server</b> When this option is selected, the system will act as a DHCP Server on this LAN, allocating address to other devices on the network and to PPP Dial in users.</li> <li>• <b>Disabled</b> When this option is selected, the system will not use DHCP. It will not act as a DHCP server and it will not request an IP address from a DHCP server on this LAN.</li> <li>• <b>Dial In</b> When this option is selected, the system will allocate DHCP addresses to PPP Dial In users only. On systems using DHCP pools, only addresses from a pool on the same subnet as the system's own LAN address will be used.</li> <li>• <b>Client</b> When this option is selected, the system will request its IP Address and IP Mask from a DHCP server on the LAN.</li> </ul>
<b>Server Edition Primary Server</b>	The IP address of the Primary Server. This address is used to add an IP line to the Primary Server to the configuration.
<b>Server Edition Secondary Server</b>	The IP address of the Secondary Server. This address is used to add an IP line to the Secondary Server to the configuration.

*Table continues...*

Option	Description
<b>DNS Server</b>	This is the IP address of a DNS Server. If this field is left blank, the system uses its own address as the DNS server for DHCP client and forwards DNS requests to the service provider when <b>Request DNS</b> is selected in the service being used ( <b>Service &gt; IP</b> ).
<b>WebSocket Password</b>	Default = Blank. This option allows to set the password for <b>WebSocket Server</b> or <b>WebScket Client</b> .
<b>Confirm WebSocket Password</b>	Default = Blank. If you are changing the WebSocket password, type the new default password.

## Enterprise Branch Initial Configuration

The Initial Installation utility provides a default configuration and security settings that minimize initial installation activities and maximize security. The system must be configured with the default settings before the system can be administered by System Manager. This utility is used for new installations and after an upgrade to enable System Manager administration of the IP Office.

1. Select **File > Advanced > Launch Initial Installation Utility**.
2. In the **System Name** field, enter the appropriate system name.
3. For the **WAN Interface**, select LAN1 or LAN2. If you select LAN1, the DHCP Mode is disabled.
4. In the **IP Address** field, enter the appropriate IP address.
5. In the **IP Mask** field, enter the appropriate IP mask.
6. In the **Gateway** field, enter the appropriate gateway. Manager will create an IP route using this gateway with the selected WAN as the destination.
7. In the **DHCP Mode** section, if you selected LAN1, select the appropriate DHCP option. If you selected LAN2, DHCP Mode is disabled.
8. Select the **Under Centralized Management?** check box if you want the IP Office system to be managed by System Manager.
9. If you selected the **Under Centralized Management?** check box, a number of additional fields are shown, configure these additional fields as appropriate:
  - **SMGR Address** - the IP address of the server running System Manager
  - **SNMP Community**
  - **SNMP Device ID**
  - **Trap Community**
  - **SCEP Domain Certificate Name**
  - **Certificate Enrollment (SCEP) Password**

Select **Save**.

When you run the Initial Installation Utility, the Initial Installation utility also configures the following:

- System Status Interface (SSA) service security level – Unsecure only
- Configuration service security level –Secure, Medium

- Security Administration service security level – Secure, Medium
- OAMP Web Services service security level – Secure, Low (if locally administered)
- OAMP Web Services service security level – Secure, High (if administered by System Manager)
- Admin Client Certificate checks:-- High (if administered by System Manager)
- SCEP client active (if administered by System Manager)
- SCEP server IP address from SMGR IP address (if administered by System Manager)
- Legacy Program Code – Active (if locally administered)

If the system is administered by System Manager, the following is automatically configured:

- SNMP enabled
- SNMP trap destination 1 from System Manager IP address
- All SNMP traps active
- WebLM client active
- WebLM service address from System Manager IP address
- Remove all default extension users, leaving “NoUser” and “RemoteManager”

#### Related links

[File > Advanced](#) on page 63

## File > Advanced > Add/Display VM Locals

This option is only displayed when the configuration from an IP500 V2 systems with its **Voicemail Type** set to **Embedded Voicemail** is received in Manager. It is not shown for off-line configuration or configurations loaded from a PC file.

Selecting this option displays a list of the Embedded Voicemail prompt languages. Those languages already present on the System SD card or not supported are greyed out. Additional languages can be selected and then uploaded from Manager to the system.

When editing the system configuration in Manager, if the locale language selected for the system, a user, a short code or an incoming call route is not already present on the System SD card, Manager will display an error. **Add/Display VM locales** can then be used to upload the prompts for the required language in order to correct the error.

You can reload languages that are already installed on the System SD card. For example, you may want to reload the languages if new prompts have been added in a maintenance release. To reload existing languages, upgrade the system (**File | Advanced | Upgrade**) with the Upload System Files option checked. You can also choose **Upload System Files** from the Embedded File Management utility (**File | Advanced | Embedded File Management**).

The Recreate IP Office SD Card command can be used to locally load all available languages onto an SD card.

#### Related links

[File > Advanced](#) on page 63

## File > Backup/Restore

### Backup Binaries and Configurations

This command copies all configuration files (.cfg) and software binary files (.bin) stored in Manager's working directory to a selected folder.

### Restore Binaries and Configurations

This command copies all configuration files (.cfg) and software files (.bin) stored in a selected folder to the Manager's working directory.

#### Related links

[File Menu](#) on page 49

---

## File > Import/Export

### Export

This command allows you to export the selected parts of the configuration to either a set of CSV text files (.csv) or a single binary file (.exp).

The display shows those exportable record types for which the configuration contains records. The File Type and the Save In path can be selected at the base. The default location used is sub-directory of the Manager application directory based on system name of the currently loaded system.

Manager imports and exports CSV files using UTF8 character encoding which uses a double byte to support characters with diacritic marks such as ä. Other applications such as Excel, depending on the user PC settings, may use different single-byte encoding which will cause such characters to be removed. Care should be taken to ensure that any tool used to create or edit a CSV supports all the characters expected and is compatible with UTF8.

### Import

This command allows you to import configuration settings. Two formats are supported. Binary files (.exp) are settings previously exported from a system using File | Import /Export | Export. CSV text files (.csv) can also be exported from a system or can be created using a plain text editor.

For the selected File Type and the Look In path, the window displays the file or files found. The default location used is sub-directory of the Manager application directory based on system name of the currently loaded system.

Manager imports and exports CSV files using UTF8 character encoding which uses a double byte to support characters with diacritic marks such as ä. Other applications such as Excel, depending on the user PC settings, may use different single-byte encoding which will cause such characters to be removed. Care should be taken to ensure that any tool used to create or edit a CSV supports all the characters expected and is compatible with UTF8.

#### Related links

[File Menu](#) on page 49



---

## File > Exit

The **File** | **Exit** command exits the Manager application.

### Related links

[File Menu](#) on page 49

---

## View Menu

### View > Toolbars

Allows selection of which toolbars should be shown or hidden in configuration mode. A tick mark is displayed next to the name of those toolbars that are currently shown.

### View > Navigation Pane

Shows or hides the Navigation Pane. A tick mark appears next to the command when the pane is shown.

### View > Group Pane

Shows or hides the Group Pane. A tick mark appears next to the command when the pane is shown.

### View > Details Pane

Sets the location of the Details Pane when the Group Pane is also shown. The Details Pane can be placed either below or to the right of the Group Pane.

### View > Error Pane

Shows or hides the Error Pane. A tick mark appears next to the command when the pane is shown.

### View > Advance View

Causes Manager to switch from its simplified view to advanced view mode. Manager automatically switches to advanced view mode if a Standard Edition configuration is loaded.

### View > Simplified View

If Manager has no configuration loaded, this command switches it from advanced view to simplified view.

### View > TFTP Log

This command displays the TFTP Log window. This window shows TFTP traffic between Manager and devices that uses TFTP to send and receive files. For example, the TFTP Log below shows an Avaya IP phone requesting and then being sent its software files.

### Related links

[Menu Bar Commands](#) on page 49

## Tools Menu

### Related links

- [Menu Bar Commands](#) on page 49
  - [Tools > Extension Renumber](#) on page 82
  - [Tools > Line Renumber](#) on page 82
  - [Tools > Connect To](#) on page 83
  - [Tools > Export > User](#) on page 83
  - [Tools > SCN Service User Management](#) on page 84
  - [Tools > Busy on Held Validation](#) on page 84
  - [Tools > MSN Configuration](#) on page 85
  - [Tools > Print Button Labels](#) on page 85
  - [Tools > Import Templates](#) on page 86
  - [File > Advanced > Generate WebLM ID](#) on page 86
  - [Tools > License Migration](#) on page 87
- 

## Tools > Extension Renumber

This command allows the extension numbering of user extensions to be changed. The existing extension number range to be adjusted can be specified followed by the new start point for the range after renumbering.

The command does not alter the extension number used for hunt groups but does adjust the extension numbers of hunt group members.

### Related links

- [Tools Menu](#) on page 82
- 

## Tools > Line Renumber

On external trunks Line appearance ID numbers can be assigned to each channel supported in order to allow that channel or line to be associated with a Line Appearance button on phones that support button programming. By default all lines are automatically numbered from 701 upwards when added to the system. This command allows the lines to be renumbered from a different starting point.

### Related links

- [Tools Menu](#) on page 82

---



## Tools > Connect To

This option can be used to create H.323 IP line connections between two systems in a multi-site network, one being the system with its configuration currently loaded in Manager, the other being selected from a discovery dialog. This option is not available for Server Edition mode.

### Important:

This process will require the systems to be rebooted.

### Procedure

1. With the configuration of the first system received from that system and displayed in Manager, clicking on  or **Tools | Connect To**
2. A discovery menu is displayed and will list any other systems discovered.
3. Select the system to which connection is required.
4. Enter the login name and password for configuration access to that system.
5. Manager will switch to Small Community Network management mode, displaying the configuration of both systems.
6. Click  to save the new configuration back to each system.

### Related links

[Tools Menu](#) on page 82

---

## Tools > Export > User

This tool is used for systems being migrated to a enterprise environment managed from Avaya System Manager. Refer to the “Migrating an IP Office or B5800 Branch Gateway to an IP Office Enterprise Branch” manual for full details of the process. If you want to export a list of users and extension numbers for other purposes use **File > Import/Export**.

When performing such a migration, users are not automatically created in System Manager. The existing users must be exported to an XML file and then that file must be imported into System Manager.

This feature allows you to export all or selected users users from the current configuration to an XML file. The default filename is <SystemName>\_Users.xml.

The **Domain Name** field is added to the user names as part of the user identity in the XML file.

### Related links

[Tools Menu](#) on page 82

---

## Tools > SCN Service User Management

When managing multiple systems, it may be useful to create a common user name and password on all the systems for configuration access. This tool can be used to create a new service user account, **SCN\_Admin**, for configuration access.

This tool is also available within a Server Edition network for administration of the **Administrator** account.

This process requires you to have a user name and password for security configuration access to each of the systems.

### Procedure

1. The **Select IP Office** menu displays the list of discovered systems.
2. Select the systems for which you want to create a common configuration account.  
Click **OK**.
3. A user name and password for security configuration access to each system is requested.  
Enter the values and click **OK**. If the same values can be used for all systems enter those values, select **Use above credentials for all remaining, selected IPOs**. If each system requires a different security user names and password, deselect **Use above credentials for all remaining, selected IPOs**.
4. The systems will be listed and whether they already have an **SCN\_Admin** account is shown.
5. To create the **SCN\_Admin** account on each system and set the password for those account click on **Create Service User**.
6. Enter the common password and click **OK**.
7. The password can be changed in future using the Change Password option.
8. Click **Close**.

### Related links

[Tools Menu](#) on page 82

---

## Tools > Busy on Held Validation

**Busy on Held** is a user feature where, when the user has a call on hold, the system indicate the user as being busy to any further calls.

The use of **Busy on Held** in conjunction with multiple call appearance buttons is deprecated. This command can be used to identify those users who have multiple call appearance buttons and for whom Busy on Held is currently set.

When run, it shows a list of the users affected and if selected their Busy on Held setting will be switched off.

### Related links

[Tools Menu](#) on page 82

---

## Tools > MSN Configuration

Used to populate the **Incoming Call Route** table with a range of MSN or DID numbers.

Setting	Description
<b>MSN/DID</b>	The first number in the set of MSN numbers for which you have subscribed.   <b>Note:</b> If you require to find an exact match between the MSN numbers and the destination numbers, enter a minus (-) sign before the first MSN number.
<b>Destination</b>	Where incoming calls with matching digits should be routed. The drop-down list contains the extensions and groups on the system.
<b>Line Group ID</b>	Specifies the incoming line group ID of the trunks to which the DID routing is applied.
<b>Presentation Digits</b>	Set to match the number of digits from the MSN/DID number that the central office exchange will actually present to the system.
<b>Range</b>	How many MSN or DID number routes to create in sequence using the selected MSN/DID and Destination as start points. Only routing to user extensions is supported when creating a range of records.

### Related links

[Tools Menu](#) on page 82

---

## Tools > Print Button Labels

This option is only enabled if a version of DESI software is also installed on the same PC as Manager. It can then be used when a system configuration is loaded in Manager.

DESI software can be obtained from the Avaya support web site (<http://support.avaya.com>) or from DESI (<http://www.desi.com>). Currently, though all users are shown, only ETR, M Series, T-Series, 1400 and 1600 phones are supported by DESI templates.

The text used on the labels:

- If a text label has been added in the user's Button Programming settings, that text label is passed to the DESI application.
- Note that the DESI application cannot import non-ASCII characters and may render them incorrectly.

- Manager will display a warning if it estimates that the user's current text for some buttons may exceed the label space of the phone type.
- If no text label has been set, the default label for the action currently assigned to the button is passed to the DESI application.
- Once the labels are shown in the DESI application, the label text can be changed.
  1. Load the configuration of the system for which you want to print button labels.
  2. Select **Tools** and then **Print Button Labels**.
    - **Name/Extn** – These are the user name and extension number details of the users in the system configuration currently loaded in Manager.
    - **Phone Type** – This field shows the type of phone, if known, that the user is currently associated with. The drop down can be used to change the selection if required.
    - **Expansion Modules** – If the phone type supports additional button modules, this drop down can be used to select the type and number of button modules.
    - **Print Extn** – This check box is used to select whether the phone button details should be included in the output passed to the DESI software.
    - **Print BM1/Print BM2/Print BM3** – These check boxes are used to select whether button module button details should be included in the output passed to the DESI software. These button will only be selectable if the user's **Expansion Modules** is set to the number of button modules.
  3. Click **Print via DESI** to transfer the information to the DESI application. Within DESI, edit the labels as required and then print the labels.

#### Related links

[Tools Menu](#) on page 82

---

## Tools > Import Templates

Manager can be used to import and use templates. See [Working with Templates](#) on page 600.

Templates are stored in a default location. This command can be used to select a folder containing other template files and copy those files into the correct default folder.

#### Related links

[Tools Menu](#) on page 82

---

## File > Advanced > Generate WebLM ID

This menu is only used for Server Edition systems. Any system being upgrading from pre-Release 10 ADI licenses must be migrated to PLDS licenses before upgrading. This is done using the files created by the license migration tool. However, that tool assumes that the system will also be the licence host. If instead the system is going to use PLDS licenses hosted by a WebLM server, the

system's web license server host ID is required in addition to the files created by the license migration tool. This tool generates that additional ID.

### To generate the server's Web License Server Host ID:

1. Click **File > Advanced > Generate WebLM ID**. The menu displayed varies depending you indicate the server is virtualized or not.
2. Enter the details of the server:
  - **UUID:** For a virtualized server, the UUID can be obtained as follows:
    - Using the command line command: `dmidecode -s system-uuid`
    - From the uuid.bios line of the virtual machines vmx file.
    - From the VSphere client, see <http://www-01.ibm.com/support/docview.wss?uid=swg21682150>.
3. Click **Generate**.
4. The system's host ID is displayed. Copy and paste this value to a text file.

#### Related links

[Tools Menu](#) on page 82

---

## Tools > License Migration

IP Office release 10 and higher supports only the Product Licensing and Delivery System (PLDS) to manage license files. If you are upgrading from a previous release, you must migrate all of your pre-R10 licenses (ADI, PLDS, mix of ADI/PLDS, virtual) to R10 PLDS licenses. The license migration tool extracts all the licensing information from an IP Office system and saves it to a file. This file can then be used prepare a software upgrade quote in the Avaya One Source Configurator in order to obtain the required new PLDS R10 licenses.

For Server Edition deployments, the License Migration tool collects licensing information from every node in the solution.

For a step by step procedure, see [Migrating Licenses to PLDS](#) on page 580.

### Notes

- Ensure all licenses are loaded on the system before using the license migration tool to extract the licensing information. For Server Edition deployments, ensure all nodes are online in order to capture the current view of systems in the solution. This step must be completed before preparing your R10 software upgrade quote in the the Avaya One Source Configurator.
- License migration is supported on all IP Office modes, release 6.0 and higher.
- The license migration tool can only be used with an online configuration. The **Tools > License Migration** option is disabled for offline configurations.
- The license migration tool is not available on UCM and Application servers. When you run the license migration tool on a Server Edition server, the tool collects licensing information from every node in the solution.

- The generated file can be read but must not be edited. License migration will fail if the file has been edited.

**\* Note:**

The License Migration Tool is not used for the upgrade of an SMGR WebLM license used in certain pre-R10 Enterprise Branch deployments. For more information see the Avaya One Source Configurator.

**Related links**

[Tools Menu](#) on page 82

---

## Security Mode Menus

These commands are available when the Manager is in security configuration mode.

### **Security Settings > File > Open Security Settings**

Displays the **Select IP Office** menu to select and load a system's security settings. This requires entry of a user name and password with rights to access security settings of the selected system.

This behavior changes when configuration settings have already be received from a system using a service user name and password that also has security access rights for that system. In that case, the system's security settings are automatically loaded without requiring name and password entry.

### **Security Settings > File > Close Security Settings**

Close the currently open set of security settings received from a system without saving those settings.

### **Security Settings > File > Save Security Settings**

Send edited security settings back to the system. Requires re-entry of a service user name and password with access rights for security settings.

### **Security Settings > File > Reset Security Settings**

Reset the security settings of the selected system to defaults. Requires entry of a service user name and password with access rights for resetting the security settings. This option is not usable while a set of security configuration settings is loaded.

The command **File | Advanced | Erase Security Settings (Default)** performs the same action from Manager configuration mode.

### **Security Settings > File > Preferences**

Displays a window for configuring various aspects of Manager's operation. The window is divided into a number of tabs.

For a description of the Preferences options, see **File > Preferences**.

### **Security Settings > File > Configuration**

Returns Manager to configuration mode.



## Security Settings > File > Exit

This command closes Manager.

### Related links

[Menu Bar Commands](#) on page 49

---

# Embedded File Management Menus

For control units with a memory card installed, the contents of the card can be viewed using Manager. This view can also be used to add and remove files from the card. This may be useful when the memory card is being used to store Music on Hold or IP phone firmware files.

- For non-Linux systems, the folders accessed using embedded file management are those on the SD cards installed in the control unit.
- For Linux based systems, the folder path displays as `disk` in the embedded file manager. That path maps onto `/opt/ipoffice` on the server.

## Embedded Voicemail Files

When viewing the memory card, the files related to Embedded Voicemail are visible, however these files are greyed out (ie. cannot be deleted, downloaded or overwritten).

- Mailbox greetings and messages are shown as `.clp` files.
- The language prompts for Embedded Voicemail functions are stored in separate language sub-folders of `lvmail`. These are `.c11` files.
- Named prompt files for use by Embedded Voicemail auto attendants are stored in the `lvmail\AAG` folder and use the same `.c11` or `.c23` file formats as the language prompts. These files can be created from standard `.wav` files before being downloaded to the memory card by using the LVM Greeting Utility.

## Avaya IP Phone Files

The memory card can be used as the source of files requested by IP Phones when rebooting. For phones using system DHCP, once the files are loaded onto the card, the TFTP Server IP Address and HTTP Server IP Address on the System | System tab must be set to match the system's LAN address.

## Viewing a Memory Card

When **Advanced | Embedded File Management** is selected, the Manager will go through normal system discovery but will only allow selection of systems which can support a memory card. When a system is selected, a valid service user name and password for configuration access to that system is requested. If the system selected does not have a memory card installed, the files view remains blank and the message **TFTP:Received TFTP Error "Not Found"** appears in Manager's status bar.

## Changing the Files View

The type of display used in the **Files** pane can be changed by selecting from the **View** menu in the toolbar.

### Open File Settings

Select a system and display the contents of its memory cards if any are present and in use.

### Close File Settings

Close the current memory card contents listing without exiting embedded file management mode.

### Refresh File Settings

This command can be used to request a file update from the system.

### Upload File

This command can be used to select and upload a file to the memory card in the system.

### Upload System Files

This command is available with IP500 V2 systems. When this command is selected, Manager will upload the software files for operation to the System SD card.

#### **Warning:**

After this command is completed, the system is rebooted. This will end all calls and services in progress.

- It copies the binary files for the system control unit and possible external expansion modules.
- It copies the firmware files used by phones supported by the system.
- For systems configured to run Embedded Voicemail, the Embedded Voicemail prompts for those supported languages set as the system locale, user locales, incoming call route locales and short code locales are upgraded. In addition the English language prompts are upgraded as follows: **IP Office A-Law/Norstar SD Cards** - UK English, **IP Office U Law/PARTNER SD Cards** - US English.

### Backup System Files

This command is available with IP500 V2 systems. When selected, Manager copies the folders and files from the **System SD** card's `/primary` folder to its `/backup` folder. Any matching files and folders already present are overwritten. This action can be included as part of the system's automatic daily backup process (System | System | Automatic Backup).

### Restore System Files

This command is available with IP500 V2 systems. When selected, Manager copies the folders and files from the **System SD** card's `/backup` folder to its `/primary` folder. Any matching files and folders already present are overwritten.

#### **Warning:**

After this command is completed, the system is rebooted. This will end all calls and services in progress.

### Upgrade Binaries

This command is available for IP500 V2 systems that have a system SD card and Optional SD card installed.

When this command is selected, all files except **config.cfg** and `keys.txt` files in the Optional SD card's `\primary` folder are copied to the System SD card.

 **Warning:**

After this command is completed, the system is rebooted. This will end all calls and services in progress.

### Upgrade Configuration

This command is available for IP500 V2 systems that have a system SD card and Optional SD card installed.

When this command is selected, any **config.cfg** and `keys.txt` files in the Optional SD card's `\primary` folder are copied to the System SD card.

 **Warning:**

After this command is completed, the system is rebooted. This will end all calls and services in progress.

### Upload Phone Files

This command is available for IP500 V2 control units. When this command is selected, Manager copies the software files relating to phone firmware to the memory card. For IP500 V2 control units, use Upload System Files.

### Copy System Card

This command is available for IP500 V2 systems that have an Optional SD card installed in addition to the mandatory System SD card. When this command is selected, the system will copy the folders and files on its **System SD** card to the **Optional SD** card. Any matching files and folders already present on the **Optional SD** card are overwritten.

This process takes at least 90 minutes and can take longer.

### Configuration

This command will exit Embedded File Management and return Manager to configuration editing mode.

#### Related links

[Menu Bar Commands](#) on page 49

# Chapter 5: Manager User Interface

This section of the documentation covers the operation of Manager when being used to edit the configuration of a system running in Standard Mode. Much of it is also applicable for when also editing the configuration of systems running in Server Edition mode. Additional Server Edition Mode functions are detailed in the next chapter.

## Related links

[Title Bar](#) on page 92

[Toolbars](#) on page 92

[The Navigation Pane](#) on page 94

[The Group Pane](#) on page 95

[The Details Pane](#) on page 97

[The Error Pane](#) on page 99

[The Status Bar](#) on page 101

---

## Title Bar

The Manager title bar shows the following information.

- The Manager application version.
- The system name of the system from which the currently loaded configuration was received.
- The software level of the system's control unit.
- The service user name used to receive the configuration and that user's associated operator rights.

## Related links

[Manager User Interface](#) on page 92

---

## Toolbars

Manager displays the following toolbars:

- Main Toolbar

- Navigation Toolbar
- Details Toolbar

## Related links



[Manager User Interface](#) on page 92

## The Main Toolbar



The Main toolbar is displayed at the top of the Manager window, just below the menu bar. This toolbar is also available when Manager is in security mode. However many of the controls will not function in security mode.



 Open Configuration from a System Advertises to the address currently shown in the Manager's title bar for any available systems. A list of responding systems is then displayed. When a system is selected from this list, a valid user name and password must be entered. Equivalent to **File | Open Configuration**.

 Open Configuration File Open a configuration file stored on a PC. The button can be clicked to display a browse window. Alternatively the adjacent  arrow can be used to drop-down a list of the last 4 previously opened configuration files. Equivalent to **File | Offline | Open File**.

 Save Configuration File The action of this icon depends on whether the currently loaded configuration settings were received from a system or opened from a file stored on PC. If the former applies, the menu sending the configuration back to the system is displayed. In the latter case, the file changes are saved to the original file. Equivalent to **File | Save Configuration**.

 Collapse All Groups Causes all  symbols in the navigation pane to be collapsed to  symbols.

 Show/Hide the Navigation Pane

 Show/Hide the Group Pane

 Show/Hide the Error Pane

 Validate Configuration Runs a validation on all the currently loaded configuration settings. The results appear in the error pane. By default the configuration is automatically validated when loaded and changes are validated when made, however the validation preferences can be changed through **File | Preferences | Validation**.

 Create New Configuration Runs a series of dialogs that create a new configuration from scratch.

 Connect To For a standalone system, start the process of adding it to a multi-site network. Not available in Server Edition mode.

 Voicemail Pro Client Launch the Voicemail Pro client if also installed on the Manager PC.

 Server Edition Solution View Switch to the solution view. This option is only shown when Manager is running in Server Edition mode.

---

## The Navigation Toolbar

This toolbar provides drop down lists which can be used to navigate to particular records in the configuration settings. The selected options in the navigation pane, group pane and the details pane are synchronized with the navigation toolbar and vice versa. This toolbar is particularly useful if you want to work with the group pane and or navigation pane hidden in order to maximize the display space for the details pane.

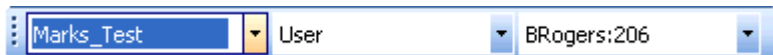

This toolbar is not available when Manager is in security mode.

---

## The Details Toolbar

This toolbar is shown in the top-right of the details pane. The options within the toolbar may vary or be greyed out depending on the actions allowed for a particular configuration record.



 **Create a New Record** The ▼ arrow is used to select the record type to be created. For example; when adding an extension clicking ▼ may allow selection of a VoIP Extension or IP DECT Extension.

 **Export as Template** Save the current record as a template. The template can then be used to create new records.

 **Delete Current Record** Delete the currently displayed record.

 **Validate Current Record** By default records are validated when opened and when edited. This is set through the Manager application's validation settings.

 **Previous Record/Next Record** Click < or > at the top-right to move to the previous or next record.

---

## The Navigation Pane

This pane shows icons for the different types of record that the configuration can contain. Each type is followed by the number of records of that type already in the configuration. When Manager is used in security mode, this pane is also used by Manager in security mode to display records for security settings.

Selecting an icon displays the matching records in the group pane, navigation toolbar and details pane. Note that Manager is used to configure different types of system. Therefore the icons shown may vary depending on the type of system you are configuring. For descriptions of the different icons refer to Configuration Settings.





The information in the pane also depends on whether the group pane is visible or not. If the group pane is visible, the navigation pane just shows icons for accessing which types of records should be shown in the group pane. The group pane can then be used to select which of those records is currently shown in the details pane. If the group pane is not visible, the navigation pane shows icons for each type of records and under those icons for each individual record. The navigation pane can then be used to select which of those records is currently shown in the details pane.

### Related links

[Manager User Interface](#) on page 92

---

## Expanding and Collapsing the Navigation Tree

Where  or  icons appear in the pane, they allow the structure to be expanded or collapsed. When the group pane is hidden,  and  icons are shown for each record type and allow the record type to be expanded to display all the existing records of that type.

The  icon in the main toolbar can also be used to collapse all the expanded record types shown in the navigation pane.

---

## The Group Pane

This pane lists all the records that match the type selected in the navigation pane or navigation toolbar. The list can be sorted by clicking on a column heading. Selecting a record in this pane displays its details in the details pane.

The icons used in the pane may vary according to the state of the record. For example, some of the users shown in this example have been configured for hot desking. This pane is also used by Manager in security mode to display records for security settings.

### Related links

[Manager User Interface](#) on page 92

---

## Sorting the List

### About this task

The records shown in the group pane can be sorted using any of the columns displayed.

### Procedure

1. To sort the list using the details in a particular column, click on the column header.
2. Clicking on the same column header again reverses the sort order.

---

## Customizing the Columns Displayed

### About this task

For each record type, which details are shown in the group pane can be customized. Also the order of the column can be adjusted.

### Procedure

1. Right-click on the pane and select **Customize Columns**.
2. To add a column, select its name in the left-hand **Available Columns** list and click **>>** to move it to the right-hand **Selected Columns** list.
3. To remove a column, select its name in the right-hand **Selected Columns** list and click **<<** to move it to the left-hand **Available Columns** list.
4. To change the order of the **Selected Columns**, click on a column name and use the **^** and **V** controls.
5. Click **OK**.

---

## Changing the Column Widths

### About this task

### Procedure

1. In the column headers, place the cursor over the border between two columns.
2. When the cursor changes to a double headed arrow with a bar through it, click and hold the cursor.
3. Drag the border to the required position and release the cursor.

---

## Adding a New Record

### About this task

The group pane can be used to add a new record of the type currently displayed.

Right-click on the pane and select **New**.

A **▶** arrow symbol next to **New** indicates that you can select a particular type of new record to create. Click the arrow and select an option from the list.



### Procedure

1. Use the details pane to configure the new record.
2. Click **OK** in the details pane.

---

## Deleting an Record

### About this task

#### Procedure

1. Select the record to be deleted by clicking on it.
2. Right-click on the pane and select **Delete**.

---

## Validating an Record

### About this task

#### Procedure

1. Select the record to be validated by clicking on it.
2. Right-click on the pane and select **Validate**.

---

## Show in Groups

### About this task

This command groups the items shown in the group pane. The grouping method will vary depending on the record type being listed. For example, short codes are grouped based on short code feature type such as all forwarding short codes together.

#### Procedure

Right-click on the pane and select **Show In Groups**.

---



## The Details Pane

Whenever a selection is made through the group pane or the navigation toolbar, the settings for the matching record are shown in the details pane. This pane is also used by Manager in security mode to display records for security settings.





The details are grouped into tabs. The tabs available may vary depending on what particular type of record is being viewed.

Individual settings may also be grayed out. This indicates that they are either for information only or that they cannot be used until another setting is enabled.

The top-left icon indicates the following:

	<b>Locked</b> Indicates that you can view the settings but cannot change them.
	<b>Editable</b> Indicates that you can change the settings if required.
	<b>Changed</b> Indicates that the settings have been changed since the tab was opened. Click OK to save the changes or Cancel to undo.

Various icons may appear adjacent to settings:

	<b>Locked Setting</b> The setting cannot be changed through this tab. This icon appears on user settings where the user is associated with User Rights that controls the setting.
	<b>Information</b> Indicates a value which does not have to be set but may be useful if set.
	<b>Warning</b> A warning indicates a configuration setting value that is not typical and may indicate misconfiguration.
	<b>Error</b> An error indicates a configuration setting value that is not supported by the system. Such settings may cause the system to not operate as expected.

**Related links**

[Manager User Interface](#) on page 92

[Managing Records](#) on page 98

## Managing Records





### Procedure

1. Edit a record
  - a. The method of entering a record varies as different fields may use different methods. For example text record boxes or drop down lists.
  - b. By default when changes are made, they are validated once another field is selected. See **File | Preferences | Validation**.
  - c. Click on **OK** at the base of the details pane to accept the changes or click on **Cancel** to undo the changes.

2. Add a record.
  - a. Click  at the top-right of the details pane.
  - b. Select the type of record required. For example, with extensions you can select from **H.323 Extension** or **SIP Extension**.
3. Delete a record.
 

Click  at the top-right of the details pane.
4. Validate a record.
 

Click  at the top-right of the details pane.
5. Move to the previous or next record.
 

Click  or  at the top-right to move to the previous or next record.
6. Select a new tab.
  - a. To view the detail stored on a particular tab, click on the name of that tab.
  - b. If the tab required is not shown, use the   controls if shown on the right to scroll through the available tabs. The tabs available may vary depending on what particular type of record is being viewed.

### Related links

[The Details Pane](#) on page 97

---

## The Error Pane

Validation is a process where Manager checks configuration records for errors or for values for which it regards as requiring a warning. The results of this checking are shown by icons next to the field that caused the error or warning. All errors and warnings are also listed in the Error Pane.

By default validation is performed automatically whenever a configuration file is opened and when any field is edited. However, if required, the use of automatic validation can be controlled through the settings on the File | Preference | Validation tab.

### Icons

The icons used for errors and warnings are as follows. These are shown in the error pane and also next to the related field in the details pane. In the details pane, the error or warning description is shown when the cursor is hovered over the icon.

 **Error** An error indicates a configuration setting value that is not supported by the system. Such settings are likely to cause the system to not operate as expected.

 **Warning** A warning indicates a configuration setting value that is not typical and may indicate misconfiguration.

 **Information** Typically indicates a setting which may be useful to set.

## Related links

[Manager User Interface](#) on page 92

---

# Altering the Automatic Validation Settings

## About this task

The settings for automatic validation are adjustable.

## Procedure

1. Select **File | Preferences**.
2. Select the **Validation** tab.

Select the options required.

- **Validate configuration on open** Automatically validate configuration files when they are opened in Manager.
- **Validate configuration on edit** Validate the whole configuration when **OK** is clicked after editing a record. For large configurations, disabling this option removes the delay caused by validating the configuration after every edit.
- **Prompt for configuration validation on save or send** If selected, when saving or sending a configuration, a prompt is displayed asking whether the configuration should be validated. If validation is selected and error are found, the send or save process is canceled. This option is disabled if Validate configuration on edit is selected.

3. Click **OK**.



---

# Revalidating Configuration Settings

## About this task

If necessary, you can force a validation check of the whole configuration or of the current record shown in the details pane.

## Procedure

1. To validate the whole configuration, click  in the main toolbar.
2. For a particular record, click  in the details pane.

---

# Viewing an Error or Warning

## About this task

## Procedure

1. Clicking on an error or warning in the error pane will load the matching record tab into the details pane.

2. The < and > can be used to move to the next error or warning in the error pane.

---

## The Status Bar

The status bar at the base of the Manager screen is used to display icons and messages about communications between Manager and systems. If the Manager is also acting as a BOOTP and TFTP server it will also show BOOTP and TFTP messages.

A padlock icon is displayed whenever the Manager communications settings are set to secure. This indicates all attempted configuration and security settings exchanged will be attempted over a secure TLS link:

Status bar messages display information about communications the Manager application receives. Some typical status bar messages are listed below.

### Ready

This message is normally seen when Manager has just started and no configuration has been received.

### Received BOOTP request for 001125465ab2, unable to process

Manager is acting as a BOOTP server. It has received a BOOTP request that does not match a system listed in its BOOTP records. The cause may be a device or application, other than an IP Office, that also uses BOOTP.

### TFTP: Received TFTP Error "NotFound" from 192.168.42.1

An attempt to receive settings from or send settings to the system failed. The most probable cause is a name or password error.

### TFTP: Received 17408 bytes for Marks\_Test

Manager has received configuration settings from the named system using TFTP.

### Sent 100% of C:\Program Files\Avaya\IP Office\Manager\b10d01b2\_3.bin

Manager has sent the indicated file in response to a BOOTP request.

### Related links

[Manager User Interface](#) on page 92

---

## Configuring the Interface

The Manager configuration settings interface can be customized in a number of ways. These changes are remembered the next time Manager is started.

## Related links

[Manager User Interface](#) on page 92

---

## Resizing the Manager Window

### About this task

When the Manager window is not maximized or minimized, its size can be adjusted.

### Procedure

1. Place the cursor over the edge of the current window.
  2. When the cursor changes to a double-headed arrow, click and hold the cursor.
  3. Drag the edge to the required position and then release the cursor.
- 

## Moving the Border Between the Panes

### About this task

The border between the visible panes can be adjusted. Note that this is a proportional rather than exact position. If the whole window size is altered, the border position may also move.

### Procedure

1. Place the cursor over the border between two panes.
  2. When the cursor changes to a double-headed arrow with a bar through it, click and hold the cursor.
  3. Drag the border to the required position and release the cursor.
- 

## Showing or Hiding Toolbars

### About this task

The different toolbars can be hidden if not required.

### Procedure

1. Select **View** and then **Toolbars**.  
Those toolbars currently shown are indicated by a tick mark.
2. To show or hide a toolbar, click on its name.

---

## Moving Toolbars

### About this task

The position of the Manager toolbars can be moved. Note that when moving a toolbar, the other toolbars and panes may adjust their size or position to ensure that all the toolbar icons remain visible.

### Procedure

1. Place the cursor over the end of the toolbar.
2. When the cursor changes to a four-way arrow, click and hold the cursor.
3. Move the toolbar to the required position and release the cursor.



---

## Showing or Hiding Panes

### About this task

The details pane cannot be hidden. The navigation pane, group pane and error pane can be shown or hidden. To do this use either of the following methods.

From the main toolbar, use the following icons:

-  **Hide/Show Navigation Pane.**
-  **Hide/Show Group Pane.**
-  **Hide/Show Error Pane.**

or

### Procedure

1. Select **View**.  
Those panes currently shown are indicated by a tick mark.
2. To show or hide a pane, click on its name.

---

## Changing the Position of the Details Pane

### About this task

When the group pane is visible, the details pane is shown either below it or to its right. This position can be adjusted.

### Procedure

1. Select **View** and then **Details Pane**.

2. The current position setting is indicated by a tick mark.
3. To select a position, click on it.

---

## Changing the Size of Configuration Icons

### About this task

The size of the icons used on the navigation pane and details pane can be adjusted.

### Procedure

1. Select **File** and then **Preferences**.
2. Select the **Visual Preferences** tab.
3. Select the required icon size from **Small**, **Medium** or **Large**.
4. Click **OK**.

---

## Changing Tab Display

### About this task

For records with more than two tabs, you can select whether Manager should use  controls or arrange the tabs as multiple rows when necessary.

### Procedure

1. Select **Files | Preferences | Visual Preferences**.
2. Select **Multiline Tabs**.
3. Click **OK**.



# Chapter 6: Working with the Server Edition Manager User Interface

## Related links

[Server Edition Solution View](#) on page 105

[System Inventories](#) on page 108

[Default Settings](#) on page 108

[Record Consolidation](#) on page 109

[Telephone Features Supported Across Server Edition and SCN Networks](#) on page 110



---

## Server Edition Solution View

When the configuration of a Server Edition solution is loaded into Manager, Manager starts with the **Server Edition Solution View** menu. This menu includes the system inventory of the servers, links for launching various functions and a summary table of the servers and the links between the servers.





### Displaying the Server Edition Solution View

Manager normally starts with the Server Edition Solution View when the configuration for a Server Edition network is loaded. However, if required, to return to the solution view do one of the following.

- Click on the  **Server EditionSolution View** icon in the toolbar.
- Click on the  **Solution** icon in the navigation pane.

### Interpreting and Using the Network Table

The table at the bottom of the solution view give a quick overview of all the servers and whether their configuration was loaded into Manager.

<b>Description</b>	<p>This column describes the type of server being detailed by the row. It also includes a status indicator for the configuration file that Manager has loaded for the server.</p> <ul style="list-style-type: none"> <li>•  <b>Green - Configuration Loaded</b> The configuration of the server has been successfully retrieved and can be edited in Manager.</li> <li>•  <b>Yellow - Offline Configuration Loaded</b> The configuration loaded is an offline configuration. This will appear for a server that has been added to the solution when the physical server is not currently connected on the network and <b>Create Offline Configuration</b> was selected. The offline configuration file is stored on and retrieved from the primary server until it can be replaced by or replace the actual server configuration.</li> <li>•  <b>Red - Configuration Not Loaded</b> There is no configuration for the system loaded even though the solution configuration includes an entry for the server. This will appear for a server that has been added to the network when the physical server is not currently connected on the network and <b>Create Offline Configuration</b> was not selected. It may also appear if the server is currently not contactable.</li> <li>•  <b>Grey - No Connection</b> This icon is used in conjunction with the others to indicate that there is no current connection to the server. For example: <ul style="list-style-type: none"> <li>• In conjunction with a green icon, it indicates that the server for which a configuration has been loaded cannot be detected on the network. This may be a temporary issue caused by that particular server rebooting following a configuration change.</li> <li>• In conjunction with a red icon, it indicates that the server for which a configuration has not been loaded has now been detected on the network. Saving and reloading the solution configuration may resolve the issue.</li> </ul> </li> </ul>
<b>Name</b>	This is the server name as taken from its configuration file. <b>Offline</b> is shown if no configuration file is available.
<b>Address</b>	The IP address of the server. This is the address that is used when Manager attempts to retrieve the servers configuration when loading the solution configuration.
<b>Primary Link</b>	This value indicates the configuration settings of the H.323 IP trunk between the primary server and the server indicated by the row. It should state <b>Bothway</b> . If it states anything other, that indicates a mismatch in H.323 IP trunk configuration between the system and the primary server. To correct this, right-click on the row and select <b>Connect to Primary</b> .
<b>Secondary Link</b>	This column is only shown after a secondary server has been added to the configuration of the solution. The value indicates the configuration settings of the H.323 IP trunk between the secondary server and the server indicated by the row. It should state <b>Bothway</b> . If it states anything other, that indicates a mismatch in H.323 IP trunk configuration between the system and the secondary server. To correct this, right-click on the row and select <b>Connect to Secondary</b> .
<b>Users Configured</b>	This column summarizes the number of users (other than <b>NoUser</b> ) configured on the server. A total for the whole network is shown in the <b>Solution</b> row.

*Table continues...*

<b>Extensions Configured</b>	This column summarizes the number of extensions configured on the server. A total for the whole network is shown in the <b>Solution</b> row.
------------------------------	----------------------------------------------------------------------------------------------------------------------------------------------

Right-clicking on a server in the table may present a number of action. The actions available vary with the current state of the network configuration.

- **Remove** Remove the server from the solution configuration.
- **Connect to Primary** Repair the configuration of the H.323 IP trunks between the server and the primary server.
- **Connect to Secondary** Repair the configuration of the H.323 IP trunks between the server and the secondary server.
- **Create Offline Configuration** Create an offline configuration file for a server for which no actual configuration has been loaded. The Offline Configuration menu will be displayed followed by the Initial Configuration menu for the server type. The offline configuration file is saved on the primary server.

### Open...

The right side of the solution view contains links to open the following tools.

- Configuration
- System Status
- Voicemail Administration
- Resiliency Administration
- On-boarding
- IP Office Web Manager
- Help

### Set All Nodes to Select

Use this command to implement Select licensing in a IP Office Server Edition Solution. All systems in the solution must use the same licensing type.

### Set All Nodes License Source

All systems in the Server Edition solution must use the same license source. The license source is defined by the configuration setting **License | License | License Source**. Use this setting to set all nodes to use the same license source.

### Add...

Add a Server Edition Secondary Server or an Server Edition Expansion System.

When you add a system, IP Office Lines connecting the new system are configured with default settings.

### Important:

If the Manager setting **File > Preferences > Preferences > SE Central Access** is set to **On**, an IP Office Line is not configured from the new system to the Server Edition Primary Server. The status of the new system is **Offline**. You must configure an IP Office Line from the new system to the Server Edition Primary Server.

**Related links**

[Working with the Server Edition Manager User Interface](#) on page 105

---

## System Inventories



Manager can be used to display a system inventory for any of the servers in the Server Edition solution. The system inventory is a quick summary of key settings and information about the server. It can also display an overview system inventory for the whole Server Edition solution.

**Displaying a Server's System Inventory**

The method for displaying the system inventory depends on what is currently being displayed by Manager.

In the Server Edition Solution View, using the table at the bottom of the menu, click on the server for which you want to display the system inventory. Click on **Network** for the inventory of the Server Edition network.

or

In the navigation pane, click on the  icon of the server for which you want to display the system inventory. Click on the  **Network** icon for the inventory of the Server Edition network.

**Related links**

[Working with the Server Edition Manager User Interface](#) on page 105

---

## Default Settings

Most of the defaults for systems in a Server Edition solution match those of individual IP Office systems as detailed in the Configuration Settings section. The table lists some differences.

All auto-create extension and auto-create user settings for IP devices are set to off.

Settings		Primary Server	Secondary Server	Expansion System
<b>System</b>	<b>Time Settings</b>	Hidden. Time taken from host server.	SNTP from the primary server.	
	<b>Voicemail</b>	Voicemail Pro	Centralized Voicemail to the primary server	
	<b>Alarms</b>	Syslog relay all alarms to the local host.	Syslog relay all alarms to the primary server.	
	<b>IP Address</b>	Specified during initial configuration menu.		
<b>Lines</b>	<b>Physical</b>	–	–	Auto-created

*Table continues...*

Settings		Primary Server	Secondary Server	Expansion System
	<b>IP Lines</b>	H.323 line to the secondary and each expansion system. Backup to secondary.	H.323 line to the primary and each expansion system. Backup to primary.	H.323 line to the primary and to the secondary if present. No backup.
<b>Extension</b>	<b>Physical</b>	–	–	Auto-created but no base extension setting.
	<b>IP</b>	None	None	None
<b>User</b>		None	None	None
<b>Hunt Group</b>		None	Not allowed	Not allowed
<b>Incoming Call Route</b>		None	Replicated from primary.	
<b>Directory</b>		Stored on the primary	Configured to obtain system directory from the primary server.	
<b>User Rights</b>		None	Replicated from primary.	
<b>ARS</b>	<b>50:Main</b>	Short code to secondary	Short code to primary	Short code to primary and to secondary if present.

### Related links

[Working with the Server Edition Manager User Interface](#) on page 105

---

## Record Consolidation

By default, to maintain the configurations of the systems in a Server Edition solution in synch, certain types of configuration records are consolidated. That is, they are replicated in the individual configuration of each system in the network. Consolidation is applied to:

- **Short Code** System short codes only.
- **Time Profile**
- **Account Code**
- **User Rights**
- **Location** Though consolidated, the **Emergency ARS** and **Fallback System** field settings of each location are configured separately at individual system level.
- **Incoming Call Route** For release 9.1 and higher, record consolidation is no longer applied to Incoming Call Routes.

In Web Manager, consolidated records are shown at the top the **Solutions** page, under **Solution Objects**. In Manager, operation of record consolidation is controlled by the **File > Preferences > Preferences** setting **Consolidate Solution to Primary Settings**. By default that setting is selected. The setting has the following effects.

If **Consolidate Network to Primary Settings** is selected:

- Entry and administration of consolidated records is performed only at the solution level except for the **Emergency ARS** and **Fallback System** field settings of location records.
- Those records are then automatically replicated in the configurations of all the systems in the solution but, except for locations, are still only visible and editable at the solution level.
- When the configurations are loaded or when this setting is changed to become selected, if any inconsistency between records are found, a **Consolidation Report** is displayed. This report allows selection of whether to update the system to match the primary or to update the primary to match.

If **Consolidate Network to Primary Settings** is not selected:

- Entry and administration of consolidated records can be performed at both the solution and individual system levels.
- Records entered and edited at the solution level are automatically replicated in the configurations of all the systems in the solution. Each record displays a label on the record indicating that it is a record that is shared across the solution.
- If a shared record is edited at the individual system level, that copy of the record is no longer shared with the other systems. It will not be updated by any changes to the solution level version of the same record.
- No consolidation checking for inconsistencies is done when the configurations are loaded.

#### Related links

[Working with the Server Edition Manager User Interface](#) on page 105

---

## Telephone Features Supported Across Server Edition and SCN Networks

Each system running IP Office in a multi-site network acts as a self-contained IP Office telephone system. In addition to the remote systems sharing knowledge of user and hunt group extension numbers, the following additional telephony features are supported between systems in a multi-site network. Features not listed are not supported across the multi-site network.

- **Absence Text**
- **Advertised Hunt Groups** Hunt groups set to advertised can be dialed by users on other systems
- **Anti-tromboning** Calls routed across the multi-site network and back to the originating system are turned back into internal calls on the originating system only.
- **Break Out Dialing**
- **Call Park / Unpark Call**
- **Call Pick-up Extension**

- **Call Tagging**
- **Callback When Free**
- **Centralized Call Log**
- **Centralized Personal Directory**
- **Conference**
- **Distributed Hunt Groups**
- **Distributed Voicemail Server Support** When using Voicemail Pro, each system can support its own Voicemail Pro server.
- **Enable ARS / Disable ARS**
- **Extension Dialing** Each system automatically learns the user extension numbers available on other systems and routes calls to those numbers.
- **Resiliency Options**
- **Fax Relay**
- **Follow Me Here / Follow Me To**
- **Forwarding**
- **Hold** Held calls are signalled across the network.
- **Internal Twining**
- **Intrusion Features**
- **Mobile Call Control** Licensed mobile call control users who remote hot desk to another system take their licensed status with them.
- **Music On Hold Source Selection**
- **Remote Hot Desking**
- **Set Hunt Group Out of Service / Clear Hunt Group Out of Service**
- **Transfer** Calls can be transferred to network extensions.
- **User DSS/BLF** Monitoring of user status only. The ability to use additional features such as call pickup via a USER button will differ depending on whether the monitored user is local or remote. Indication of new voicemail messages provided by SoftConsole user speed dial icon is not supported.
- **User Profile Resilience** When a user hot desks to another system, they retain their Profile settings and rights.

#### Related links

- [Working with the Server Edition Manager User Interface](#) on page 105
- [Configuring Small Community Networking](#) on page 786

# Part 2: Security Configuration



# Chapter 7: Security Administration

The security settings are stored on the system and are separate from the system's configuration settings. To change a system's security settings, Manager must first be switched to security mode by selecting **File | Advanced | Security Settings** from the menu bar.

Security settings can only be loaded directly from a system. These settings cannot be saved as a file on the local PC, nor do they appear as a temporary file at any time. You can optionally secure the link between the system and Manager for configuration and security settings exchanges. By default Manager and the system will always attempt to use the original, unsecured link.

Administration security is achieved using a number of optional cryptographic elements:

- Access control to prevent unauthorized use.
- Encryption to guarantee data remains private.
- Message Authentication ensures data has not been tampered with.
- Identity assures the source of the data.

## Related links

[Service Users, Application Roles, and Rights Groups](#) on page 113

[Access Control](#) on page 127

[Encryption](#) on page 128

[Message Authentication](#) on page 129

[Certificates](#) on page 130

[Implementing Security](#) on page 131

[SRTP](#) on page 133

---

## Service Users, Application Roles, and Rights Groups

In IP Office system, the managing, provisioning, and controlling the access to a system is based on assigned Roles and Rights groups to a Service user. You can manage user access to the IP Office system by assigning your Service users to various Rights groups. The Rights groups also contain Application roles for IP Office Manager and IP Office Web Manager. The settings of these roles determine the type of access a Service User has within the application. Roles and Rights groups provide multiple levels of security to IP Office Manager and IP Office Web Manager. Each Application role defines a set of permissions for a specific resource within the application. When you assign an Application role to a Rights group and then assign Service users to that Rights

group, you grant those service users all the access permissions that are defined by the Application role.

Access to system settings is controlled by **Service Users** and **Rights Groups** stored in the control unit's security settings. These are stored separately from the system's configuration settings. All actions involving communications between Manager and the system require a service user name and password. That service user must be a member of a Rights Group with permissions to perform the required action.

**Security Administrator:** The security administrator can access the system's security settings and the account cannot be removed or disabled.

In addition a further security setting can force this account to have exclusive security rights, preventing another Service Users from security settings access.

**Service Users:** Each service user has a name, a password and is a member of one or more Rights Groups. The accounts may be in one of a number of states, including enabled, disabled, locked out and enforced password change.

IP Office supports a maximum of 64 Service Users.

**Rights Groups:** The Rights Groups to which a service user belongs determine what actions they can perform. It can be thought of as a role, but has much more flexibility. Actions available to Rights Groups include configuration, security actions and maintenance actions. Where a service user has been configured as a member of more than one Rights Group, they combine the functions available in the separate Rights Groups.

IP Office supports a maximum of 32 Rights Groups.

**Application Roles:** In addition to rights of IP Office service access, Rights Groups can also contain 'Roles' for IP Office Manager and Web Manager; the settings of these roles determine what rights of access the Service User has within that application. It allows more granularity of access control within that application than the basic service access rights. For example the IP Office configuration service has two basic rights of access: Read All and Write All. However the Manager Operator roles can further constrain what can be written, viewed or edited.

### Example Rights Assignment

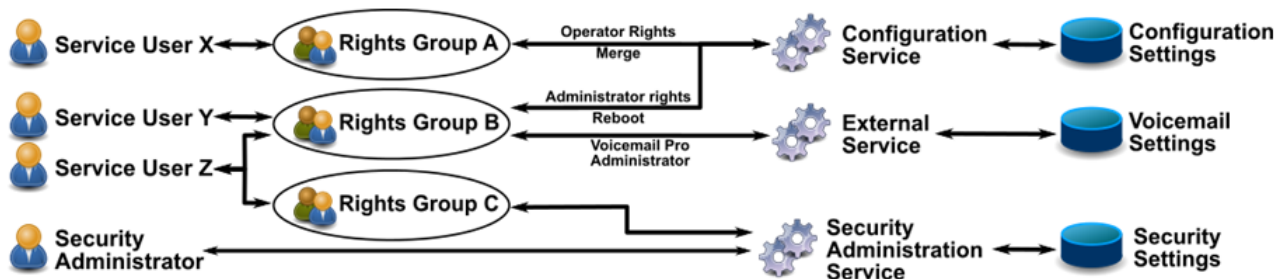

In the above illustration:

- Service user X can read and write the configuration. However they can only edit Operator settings and can only make changes that can be merged.
- Service user Y can read and write the configuration, edit all settings and make changes that require reboots or merges. They can also access the Voicemail Pro settings.

- Service user Z can read and write the configuration, edit all settings and make changes that require reboots. They can also access the security and the Voicemail Pro settings.
- The Security Administrator can only access the security settings.

## Changing Administrative Users and Rights Groups

IP Office Manager and Web Manager allow modification of Service Users and Rights Groups. Prior to any change, the following should be considered:

- A Server Edition or multi-site IP500 V2 deployment must have consistent Service Users and Rights Groups. IP Office Manager and IP Office Web Manager have synchronization tools to assist.
- All changes must follow security best practices such as password policy and minimal rights of access.

## Security Settings on Upgrade

When the IP Office system is upgraded and new rights groups or services added, existing users will only be granted the new rights if the Service Users' accounts are at default. This prevents unexpected changes of rights on upgrade. If access to these new rights or services are required, they must be added manually after the upgrade process has been completed.

## Default Service Users and Rights Groups

For IP Office Release 11.0 and prior releases, the default Service Users and Rights Groups remain the same. For more information see [Default Service Users and Rights Groups for IP Office R 11.0 and earlier](#) on page 122. A new access management is available to users on fresh installations of Powered by R3.0.3, Powered by R3.0.4, and IP Office Release 11.0 FP4. However, systems upgraded from previous versions to these IP Office releases will still have the older security settings. In fresh deployments, the only enabled account by default will be Administrator for which the password must be changed on the first login. Administrator can then enable other default user accounts by using IP Office Manager security settings or using the Service User screen on IP Office Web Manager. The new access management has fewer Service user accounts compared to the previous releases.

### Related links

[Security Administration](#) on page 113

[Default Service Users and Rights Groups](#) on page 115

[Default Service Users and Rights Groups for IP Office R 11.0 and earlier](#) on page 122

---

## Default Service Users and Rights Groups

The following information is applicable for IP Office R11.0 FP4 and Powered by Avaya Release 3.0.3 and 3.0.4.

### Security Administrator Account

The following Security Administrator account is present on first startup and security settings reset.

Name	Default Account Status	Usage	Rights Group Membership	Notes
Security	Enabled, Force password change	This is the default security administration account. Has all rights to all security management and maintenance services	Implied all security rights	Cannot be removed or disabled

### Service User Accounts

The following Service User accounts are present on first start-up and security settings reset.

Name	Default Account Status	Usage	Rights Group Membership	Notes
Administrator	Enabled, Force password change	This is the default account used for system configuration using the IP Office and Web Manager applications, including one-X Portal/Voicemail Pro administration. Has all rights to all management and maintenance services including security settings.	Administrator, System Status, Business Partner	This Service User should not be removed, disabled, or renamed.
BusinessPartner	Disabled Force password change	Similar access rights to Administrator and can be used as a separate account for Business Partners	Business Partner	This Service User can be removed or disabled if not required.
CustomerAdmin	Disabled Force password change	A Customer Administrator Service User can edit the system configuration settings.	Customer Admin	-
MCMAdmin	Disabled	The MCMAdmin Service User can administer IP Office using Cloud Operations Manager and can write own Service User password.	MCM Admin	-

*Table continues...*

Name	Default Account Status	Usage	Rights Group Membership	Notes
EnhTcpaService	Enabled	This account is used for Avaya one-X® Portal connections to the IP Office system.	TCPA Group	Although not enforced, the password should be changed as soon as possible in both IP Office and Avaya one-X® Portal.  Enable this Service User only when Avaya one-X® Portal is deployed.
DirectoryService	Enabled	This account has Read and Write service access rights to Directory Read and Directory Write in HTTP.	Directory Group	-
IPDECTService	Disabled	This account is used for DECT R4 system provisioning	IPDECT Group	Enable only when DECT R4 deployed and provisioning mode active

## Rights Groups

The following Rights Groups are present on first start-up and security settings reset.

Name	Usage	Rights Group User	Notes
Administrator Group	Allows full configuration and security access to the IP Office Manager and IP Office Web Manager application to configure the system.	Administrator	All IP Office Manager operations are permitted
Business Partner	To enable effectively management of hosted IP Office systems.	Business Partner	<ul style="list-style-type: none"> <li>• Can only create or modify Customer Admin users</li> <li>• Will not have any security configuration write related rights on fresh install or upgrading from default.</li> </ul>
MCM Admin	Service Monitor Read using Cloud Operations Manager. Allows writing own Service User password and Upgrade.	MCM Admin	Used for IP Office administration through Cloud Operations Manager.

*Table continues...*

Name	Usage	Rights Group User	Notes
Customer Admin	Provides a targeted view to end customers who have little or no prior IP Office experience. The Web Manager Right of Customer Admin will restrict the Web Manager view and access to a subset of configuration.	Customer Admin	<p>Customer Admin Service Users can log in and operate on port 8443 only and hence will be working through Web Service service rights and not HTTP service right in Powered by Avaya deployments. Customer Admin cannot use options that would require a restart of the system for the new option to apply (offline-mode) and cannot access the security settings.</p> <p>Customer Admin will not have security configuration related rights and hence will have access to limited configuration screens. Lines will also not be accessible objects. Customer Admin can change its own password using Web Manager and download the root CA certificates.</p> <p>IP500 V2 specific objects that will not be part of Customer Admin account in IP Office Powered by Avaya solution - IP Routes, WAN Ports, Firewall Profiles, RAS, Services, Tunnel (applicable for IP500 V2 only)</p>
TCPA Group	This group is used by the one-X Portal for IP Office application.	EnhTcpaService	-
IPDECT Group	This group is used by the DECT R4 master base station to extract DECT settings from IP Office.	IPDECTService	-
Management API Group	Allows limited access to the IP Office Manager application to configure the system.	-	-
Directory Group	Read and write service access rights to Directory Read and Directory Write in HTTP.	DirectoryService	Used for HTTP directory access rights. If the access rights to Directory Read and Directory Write are disabled, authentication is enforced.

### Rights Group Assignment

Service	Access Right	Rights Group							
		<ul style="list-style-type: none"> <li>• 1 = Administrator Group</li> <li>• 2 = Business Partner</li> <li>• 3 = Customer Admin</li> <li>• 4 = MCM Admin</li> </ul>			<ul style="list-style-type: none"> <li>• 5 = TCPA Group</li> <li>• 6 = IPDECT Group</li> <li>• 7 = Management API Group</li> <li>• 8 = Directory Group</li> </ul>				
		1	2	3	4	5	6	7	8
Configuration	Read all configuration	✓	✓						
	Write all configuration	✓	✓						
	Merge configuration	✓	✓						
	Default configuration	✓	✓						
	Reboot/Shutdown immediately	✓	✓						
	Reboot when free	✓	✓						
	Reboot at time of day	✓	✓						
Configuration > Manager Operator Rights	Read Only								
	Administrator	✓	✓						
	Operator								
	Manager								
	User & Group Edit								
	User & Group Admin								
	Directory & Account Admin								
	Time & Attend Admin								
	ICR & User Rights Admin								
Security Admin	Read all security settings	✓							
	Write all security settings	✓							
	Reset all security settings	✓							

Table continues...

Service	Access Right	Rights Group							
		<ul style="list-style-type: none"> <li>• 1 = Administrator Group</li> <li>• 2 = Business Partner</li> <li>• 3 = Customer Admin</li> <li>• 4 = MCM Admin</li> </ul>			<ul style="list-style-type: none"> <li>• 5 = TCPA Group</li> <li>• 6 = IPDECT Group</li> <li>• 7 = Management API Group</li> <li>• 8 = Directory Group</li> </ul>				
		1	2	3	4	5	6	7	8
	Write own service user password	✓			✓				
System Status	System Status Access	✓	✓						
	Read all configuration	✓	✓						
	System Control	✓	✓						
	Sys Monitor	✓	✓						
Telephony APIs	Enhanced TSPI					✓			
	DevLink3					✓			
	Location API								
HTTP	DECT R4 Provisioning						✓		
	Directory read					✓	✓		✓
	Directory write					✓			✓
Web Services	WS Security Read All	✓	✓						
	WS Security Write All	✓							
	WS Write Basic Security	✓	✓						
	WS Security Write Own Password	✓	✓	✓	✓				
	WS Config Read All	✓	✓						
	WS Config Write All	✓	✓						
	WS Config Read Basic	✓	✓	✓					
	WS Config Write Basic	✓	✓	✓					
	Backup	✓	✓	✓	✓				

Table continues...



Service	Access Right	Rights Group							
		<ul style="list-style-type: none"> <li>• 1 = Administrator Group</li> <li>• 2 = Business Partner</li> <li>• 3 = Customer Admin</li> <li>• 4 = MCM Admin</li> </ul>			<ul style="list-style-type: none"> <li>• 5 = TCPA Group</li> <li>• 6 = IPDECT Group</li> <li>• 7 = Management API Group</li> <li>• 8 = Directory Group</li> </ul>				
		1	2	3	4	5	6	7	8
	Restore	✓	✓	✓	✓				
	Upgrade	✓	✓		✓				
	Service Monitor Read	✓			✓				
Web Manager Rights	File Manager	✓	✓						
	Service Commands	✓	✓						
	Users, Extensions	✓	✓	✓					
	Groups, Auto Attendant	✓	✓	✓					
	Incoming Call Routes, Alternate Route Selection, Short Codes	✓	✓	✓					
	System, Locations, Time Profiles, and Licensing	✓	✓	✓					
	Lines	✓	✓	✓					
	Directory, Authorization Codes, Account Codes	✓	✓	✓					
	IP Routes, WAN Ports, Firewall Profiles, RAS, Services, Tunnel (Applicable for IP500 V2 only).	✓							
	User Rights	✓	✓	✓					
Service Change	✓	✓	✓						
External	Voicemail Pro Basic								
	Voicemail Pro Standard			✓					

Table continues...

Service	Access Right	Rights Group							
		<ul style="list-style-type: none"> <li>• 1 = Administrator Group</li> <li>• 2 = Business Partner</li> <li>• 3 = Customer Admin</li> <li>• 4 = MCM Admin</li> </ul>			<ul style="list-style-type: none"> <li>• 5 = TCPA Group</li> <li>• 6 = IPDECT Group</li> <li>• 7 = Management API Group</li> <li>• 8 = Directory Group</li> </ul>				
		1	2	3	4	5	6	7	8
	Voicemail Pro Administrator	✓	✓						
	One-X Portal Administrator	✓	✓						
	one-X Portal Super User								
	Web Control Administrator	✓	✓						
	Web Control Security	✓	✓						
	WebRTC Gateway Administrator	✓	✓						
	Management API Read							✓	
	Management API Write							✓	
	Media Manager Administrator	✓	✓						
	Media Manager Standard								
	one-X CTI API								

**Related links**

[Service Users, Application Roles, and Rights Groups](#) on page 113

## Default Service Users and Rights Groups for IP Office R 11.0 and earlier

### Security Administrator Account

The following Security Administrator account is present on first startup and security settings reset.

Name	Default Account Status	Usage	Rights Group Membership	Notes
Security	Enabled, Force password change	This is the default security administration account. Has all rights to all security management and maintenance services	Implied all security rights	Cannot be removed or disabled

### Service User Accounts

The following Service User accounts are present on first start-up and security settings reset.

Name	Default Account Status	Usage	Rights Group Membership	Notes
Administrator	Enabled, Force password change	This is the default account used for system configuration using the IP Office and Web Manager applications, including one-X Portal/Voicemail Pro administration. Has all rights to all management and maintenance services including security settings.	Administrator, System Status, Business Partner	Should not be removed or disabled Should not be renamed
EnhTcpaService	Enabled	This account is used for one-X Portal for IP Office connections to the system.	TCPA Group	Although not enforced, the password should be change as soon as possible in both IP Office and one-X Portal Enable only when one-X Portal deployed
IPDECTService	Disabled	This account is used for DECT R4 system provisioning	IPDECT Group	Enable only when DECT R4 deployed and provisioning mode active
BranchAdmin	Disabled	This account is used for System Manager (SMGR) access in a branch deployment	SMGR Admin	Enable only when SMGR deployed; will be enabled when the Initial Configuration Utility (ICU) run and SMGR administration selected. Must not be renamed

*Table continues...*

Name	Default Account Status	Usage	Rights Group Membership	Notes
BusinessPartner	Disabled	Similar access rights to Administrator and can be used as a separate account for Business Partners	Business Partner	Should be removed/ disabled unless required
Maintainer	Disabled	Maintenance account without edit configuration or security access.  Can be used for Manager (read-only), Web Manager (read-only), System Status Application (SSA), Backup/Restore, System Monitor, Upgrade	Maintainer	Should be removed/ disabled unless required

### Rights Groups

The following Rights Groups are present on first start-up and security settings reset.

Name	Usage	Rights Group User	Notes
Administrator Group	Allows full access to the IP Office Manager application to configure the system.  No security or maintenance access	Administrator	All IP Office Manager operations are permitted
Manager Group	Allows limited access to the IP Office Manager application to configure the system.	–	All IP Office Manager operations permitted except: <ul style="list-style-type: none"> <li>• Delete Short Code</li> <li>• View LAN2 Settings</li> </ul>
Operator Group	Allows limited access to the IP Office Manager application to configure the system.	–	All IP Office Manager operations permitted except: <ul style="list-style-type: none"> <li>• New object creations</li> <li>• View LAN2 Settings</li> <li>• Delete Directory</li> <li>• Delete ICR</li> </ul>
System Status Group	Allows limited access to the SSA and Sys Monitor applications.	Administrator	Sys Monitor access right only checked when using service users with Sys Monitor

*Table continues...*

Name	Usage	Rights Group User	Notes
TCPA Group	This group is used by the one-X Portal for IP Office application.	EnhTcpaService	
IPDECT Group	This group is used by the DECT R4 master base station to extract DECT settings from IP Office.	IPDECTService	
SMGR Admin	This group is used by SMGR to configure IP Office.	BranchAdmin	Do not change the access rights
Security Admin	Allows access to security settings only	–	
Backup Admin	Allows access to all backup and restore services only, including one-X Portal	–	
Upgrade Admin	Allows access to the upgrade service	–	Allows upgrade of both IP Office applications and operating system
System Admin	Allows configuration of IP Office, one-X Portal and Voicemail Pro	–	
Maint Admin	Allows configuration of IP Office, one-X Portal and Voicemail Pro along with backup, restore and upgrade	–	Typically used for maintenance personnel
Business Partner	Full access to all configuration, security and maintenance services.	Administrator, BusinessPartner	
Customer Admin	Web Management , one-X Portal and Voicemail Pro administration	–	No IP Office manager access
Maintainer	Allows configuration view only, along with SSA, Sys Monitor backup, restore and upgrade		Typically used for maintenance personnel with no need for configuration changes
Directory Group	Read and write service access rights to Directory Read and Directory Write in HTTP.	–	Used for HTTP directory access rights. If the access rights to Directory Read and Directory Write are disabled, authentication is enforced.
MCM Admin	Allows Backup, Upgrade, Service Monitor Read using Cloud Operations Manager. Allows writing own service user password	–	Used for IP Office administration through Cloud Operations Manager.

### Rights Group Assignment

Service	Access Right	Rights Group						
		1	2	3	4	5	6	7
		<ul style="list-style-type: none"> <li>• 1 = Administrator Group</li> <li>• 2 = Manager Group</li> <li>• 3 = Operator Group</li> <li>• 4 = System Status Group</li> </ul>			<ul style="list-style-type: none"> <li>• 5 = TCPA Group</li> <li>• 6 = IPDECT Group</li> <li>• 7 = SMGR Admin</li> </ul>			
Configuration	Read all configuration	✓	✓	✓				
	Write all configuration	✓	✓	✓				
	Merge configuration	✓	✓	✓				
	Default configuration	✓	✓	✓				
	Reboot/Shutdown immediately	✓	✓	✓				
	Reboot when free	✓	✓	✓				
	Reboot at time of day	✓	✓	✓				
Security Admin	Read all security settings							
	Write all security settings							
	Reset all security settings							
	Write own service user password							
System Status	System Status Access				✓			
	Read all configuration				✓			
	System Control				✓			
	Sys Monitor				✓			
Enhanced TSPI	Enhanced TSPI Access					✓		
HTTP	DECT R4 Provisioning						✓	
Web Services	Security Read All							✓
	Security Write All							✓
	Security Write Own Password							✓
	Config Read All							✓
	Config Write All							✓

Table continues...

Service	Access Right	Rights Group						
		<ul style="list-style-type: none"> <li>• 1 = Administrator Group</li> <li>• 2 = Manager Group</li> <li>• 3 = Operator Group</li> <li>• 4 = System Status Group</li> </ul>			<ul style="list-style-type: none"> <li>• 5 = TCPA Group</li> <li>• 6 = IPDECT Group</li> <li>• 7 = SMGR Admin</li> </ul>			
		1	2	3	4	5	6	7
	Backup							✓
	Restore							✓
	Upgrade							✓
External	Voicemail Pro Basic							
	Voicemail Pro Standard							
	Voicemail Pro Administrator							✓
	One-X Portal Administrator							
	one-X Portal Super User							
	Web Control Administrator							
	Web Control Security							
	WebRTC Administrator							

**Related links**

[Service Users, Application Roles, and Rights Groups](#) on page 113

---

## Access Control

Access to configuration, security settings and SSA is controlled by the use of service users, passwords and Rights Groups. All actions involving communications between the Manager user and the system require a service user name and password. That service user must be a member of a Rights Group configured to perform the required action.

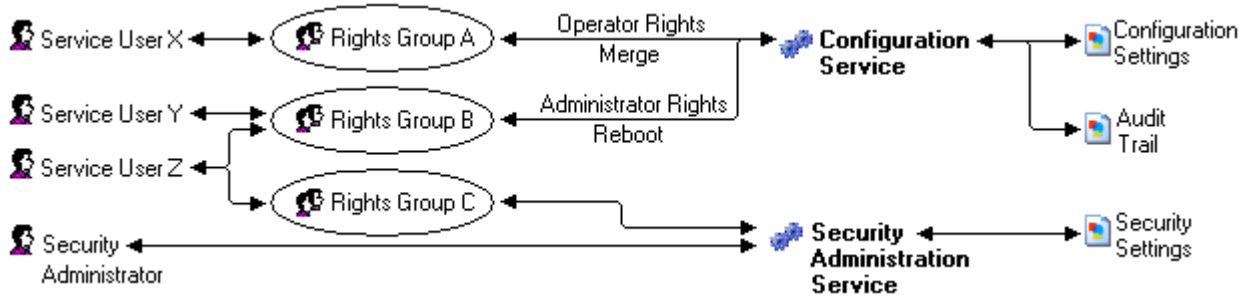

In the example illustrated above:

- Service user X can read and write the configuration. However they can only edit Operator settings and can only make changes that can be merged.
- Service user Y can read and write the configuration, edit all settings and make changes that require reboots.
- Service user Z can read and write the configuration, edit all settings and make changes that require reboots. They can also access the security settings.
- The Security Administrator can only access the security settings.

### Granular access to configuration objects group in Web Manager

Using IP Office Manager, administrators can allow or restrict Service Users from accessing configuration objects in IP Office Web Manager. Administrators can provide Read or Write access to configuration depending on the role of Service User. If a Service User does not have read or write access to a Configuration object, the objects do not appear on the interface when the Service User logs in to IP Office Web Manager. When a Service user logs in to IP Office Web Manager, system does a check on the Rights group provisioned for the Service User and shows those menus that are enabled for the Rights group.

#### Related links

[Security Administration](#) on page 113

## Encryption

Encryption ensures that all data sent by either the system or Manager cannot be 'read' by anyone else, even another copy of Manager. Encryption is the application of a complex mathematical process at the originating end, and a reverse process at the receiving end. The process at each end uses the same 'key' to encrypt and decrypt the data:



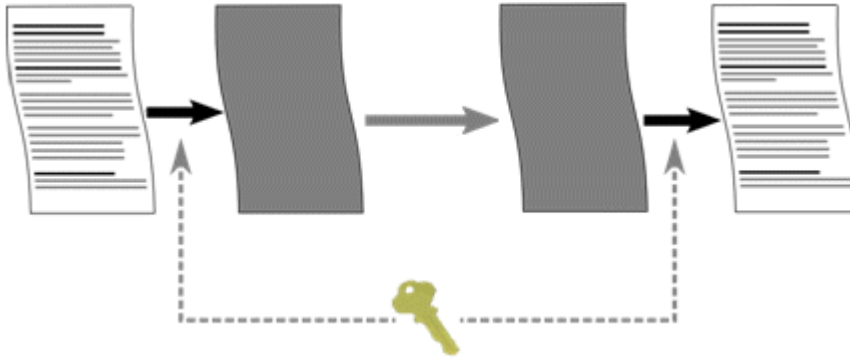

Any data sent may be optionally encrypted using a number of well known and cryptographically secure algorithms:

Algorithm	Effective key size (bits)	Use
DES-40	40	Not supported.
DES-56	56	Not supported.
3DES	112	'Minimal' security.
RC4-128	128	'Acceptable' security.
AES-128	128	'Strong' security.
AES-256	256	'Strong' security.

In general the larger the key size, the more secure the encryption. However smaller key sizes usually incur less processing. The system supports encryption using the Transport Layer Security (TLS) v1.0 protocol. In addition, many cryptographic components of the TLS module have been FIPS 140-2 certified, indicating the accuracy of implementation.

**Related links**

[Security Administration](#) on page 113

---

## Message Authentication

Message authentication ensures that all data sent by either the system or Manager cannot be tampered with (or substituted) by anyone else without detection. This involves the originator of the data producing a signature (termed a hash) of the data sent, and sending that as well. The receiver gets the data and the signature and check both match.

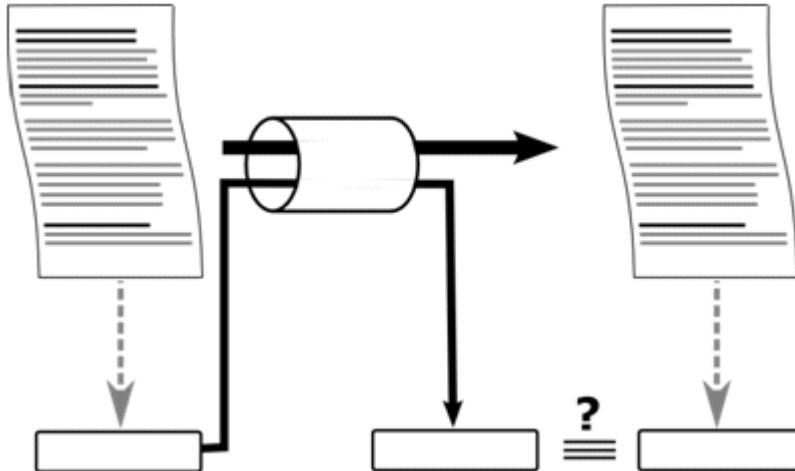

Any data sent may be optionally authenticated using a number of well known and cryptographically secure algorithms:

Algorithm	Effective hash size (bits)	Use
MD5	128	Not recommended.
SHA-1	160	'Acceptable' security.
SHA-2	256, 384, 512	'Strong' security

In general the larger the hash size, the more secure the signature. However smaller hash sizes usually incur less processing.

IP Office supports message authentication using the Transport Layer Security (TLS) 1.0, 1.1, and 1.2 protocol. In addition, many cryptographic components of the TLS module have been FIPS 140-2 certified, indicating the accuracy of implementation.

**Related links**

[Security Administration](#) on page 113

## Certificates

Public key cryptography is one of the ways to maintain a trustworthy networking environment. A public key certificate (also known as a digital certificate or identity certificate) is an electronic document used to prove ownership of a public key. The certificate includes information about the key, information about its owner's identity, and the digital signature of an entity that has verified the certificate's contents are correct. If the signature is valid, and the person examining the certificate trusts the signer, then they know they can use that key to communicate with its owner.

For more information, see [Certificate Management](#) on page 581.

**Related links**

[Security Administration](#) on page 113

---

## Implementing Security

IP Office can be made a very secure. However, only a certain number of features are active by default in order to ease the initial installation. If all Manager and system security settings are left at default, no security mechanisms are active, other than the use of default service user names and passwords. In addition, all legacy interfaces are active, and all configuration and security data is sent unencrypted. Therefore, it is necessary to implement the configuration options listed here. Additional setting may be necessary to further secure the individual deployment. Avaya is presenting this information for guidance only; the customer is responsible for ensuring their system is secure.

To improve IP Office security in practice, two main mechanisms are used:

- Activation of IP Office security features.
- Reduction of exposure to external or internal attack.

### Minimum Security

A minimum security scenario could be where configuration data is open, but the security settings are constrained: Any individual with the correct service user name and password can access the configuration from any PC installation of Manager, no logging of access: Passwords can be simple, and will never age.

- Change all default passwords of all service users and Security Administrator.
- Set the system Security Administration service security level to Secure, Low.
- Set the system service user Password Reject Action to None.
- Set the system Client Certificate Checks level to None (default).
- Set the system Minimum Password Complexity to Low (default).
- Set the system Previous Password Limit to zero (default).
- Set the system Password Change Period to zero (default).
- Set the system Account Idle Time to zero (default).
- Set certificate check level to low in Manager Security Preferences (default).

In addition, any PC installation of Manager can manage any IP Office.

### Medium Security

A medium security scenario could be where both configuration and security settings are constrained and a level of logging is required: Any individual with the correct service user name and password can access the configuration from any PC installation of Manager: Passwords cannot be simple, and will age.

- Change all default passwords of all service users and Security Administrator
- Set the system Security Administration service security level to Secure, Medium.
- Set the system Configuration service security level to Secure, Medium.
- Set the system service user Password Reject Action to Log to Audit Trail (default).
- Set the system Client Certificate Checks level to None (default).

- Set the system Minimum Password Complexity to Medium.
- Set the system Previous Password Limit to non zero.
- Set the system Password Change Period to non zero.
- Set the system Account Idle Time to zero (default).
- Disable all the system Unsecured Interfaces.
- Set certificate check level to low in Manager Security Preferences (default).

### **Maximum Security**

A maximum security scenario could be where both configuration and security settings are constrained and a full level of logging is required: Certified individuals with the correct service user name and password can access the configuration from specific PC installations of Manager: Passwords cannot be simple, and will age: Manager can managed specific systems.

- Change all default passwords of all service users and Security Administrator
- Set the system Security Administration service security level to Secure, High.
- Set the system Configuration service security level to Secure, High.
- Set the system service user Password Reject Action to Log and Disable Account.
- Set the system Client Certificate Checks level to High.
- Set the system Minimum Password Complexity to High.
- Set the system Minimum Password Length to >8.
- Set the system Previous Password Limit to non zero (>5).
- Set the system Password Change Period to non zero.
- Set the system Account Idle Time to non zero.
- Set the system Session ID Cache to zero.
- Install valid, 1024 bits+, non self signed certificates (+private key) in all IP Office server certificates, derived from a trusted certificate authority.
- Install the corresponding trusted CA certificate in each of the Manager's windows certificate stores.
- Install valid, 1024 bits+, non self signed certificate (+ private key) in all Manager Certificate Stores.
- Install the corresponding certificates in all the system Certificate Stores of all permissible Manager entities, and the trusted CA certificate.
- Disable all the system Unsecured Interfaces.
- Set Manager Certificate Checks level to high in Manager Security Preferences.
- Set Certificate offered to the system in Manager Security Preferences.

The above essentially locks the systems and corresponding Managers together. Only recognized (by strong certificate) entities may communicate successfully on the service interfaces. All services use strong encryption and message authentication.

The use of intermediate CA certificates can be used to overcome the limit of 6 maximum certificates in each system Certificate Store.

## Related links

[Security Administration](#) on page 113

---

# SRTP

Secure Real-Time Transport Protocol (SRTP) refers to the application of additional encryption and or authentication to VoIP calls (SIP and H.323). SRTP can be applied between telephones, between ends of an IP trunk or in various other combinations.

IP Office supports:

- Individual configuration for RTP and RTCP authentication and encryption
- HMAC SHA1 as the authentication algorithm
- AES-CM as the encryption algorithm
- 80 (default) or 32 bit authentication tag
- Master key length of 128 bits
- Master salt length of 112 bits.

Configuring the use of SRTP at the system level is done on the **System | VoIP Security** tab using the **Media Security** setting. The options are:

- **Best Effort**
- **Disabled (default)**
- **Enforced**

When enabling SRTP on the system, the recommended setting is **Best Effort**. In this scenario, IP Office uses SRTP if supported by the other end, and otherwise uses RTP. If the **Enforced** setting is used, and SRTP is not supported by the other end, the call is not established.

The system level setting can be overridden at the trunk or extension level. This can be used for special cases where the trunk or extension setting must be different from the system settings.

If the system level setting is **Enforced**, and devices that do not support SRTP are connected to the system, their extension level configuration must be **Disabled** or calls will fail. This extra configuration would typically not be required if the system level setting is **Best Effort**.

SRTP is supported on SIP Lines, SM Lines, and IP Office Lines. SRTP is not supported on H.323 IP trunks.

## Encrypted RTCP

IP Office supports unencrypted RTCP by default. This default is compatible with most Avaya endpoints which do not currently support encrypted RTCP. To the extent possible, any type of endpoint using SRTP with IP Office should use unencrypted RTCP for consistency with other endpoints to allow for direct media.

IP Office supports RTCP encryption as a configurable option. In addition to system level configuration, it can be turned on at the trunk and extension level. Therefore, RTCP encryption can be configured as an exception for an entity which only supports encrypted RTCP. In such case

there will be no direct media SRTP between that entity and one that does not support encrypted RTCP, and IP Office will relay the SRTP media.

## Authentication

Authentication can be applied to both the voice part of calls (the RTP stream) and or to the control signal associated with the call (the RTCP stream). By default, IP Office supports RTP encryption, RTP authentication, RTCP authentication. Authentication is applied after encryption so that packets can be authenticated at the remote end without having to be decrypted first.

- The method used for the initial exchange of authentication keys during call setup depends on whether the call is using SIP or H.323. The IP Office system uses SDESC for SIP calls and H235.8 for H.323 calls.
- SRTP is only supported when using an addition method such as TLS or a VPN tunnel to establish a secure data path before call setup.
- A replay attack is when someone intercepts packets and then attempts to use them to for a denial-of-service or to gain unauthorized access. Replay protection records the sequence of packets already received. If a packet has been received previously, it is ignored. If packets arrive outside a specified sequence range, the security device rejects them. All packets in a stream (RTP and RTCP) have a sequential index number, however packets may not be received in sequential order. SRTP protects against replay attacks by using a moving replay window containing the index numbers of the last 64 authenticated packets received or expected. Any packet received that has an index older than the current window is ignored. Only packets with an index ahead of the window or inside the window but not already received are accepted. Separate replay protection is used for the RTP and the RTCP streams.
- Rekeying is the sending of new authentication keys at intervals during an secure call. This option is not supported by the IP Office system which just sends authentication keys at the start of the call.

SRTP sessions can use direct media between the devices or can be relayed via the IP Office system. In some scenarios the IP Office system can be one end of the SRTP part of a call that then continues to a non-SRTP destination.

**If both the call originator and target require SRTP:** A direct media is made if supported, using SRTP. If direct media is not supported, the call is relayed via the IP Office system. In either case SRTP parameters are negotiated end to end with the IP Office system translating and forwarding them from one end to other end if necessary.

**If only the originator or target requires SRTP:** A non-direct media call is setup with with SRTP negotiated between the IP Office system and the party which requires SRTP.

## Emergency Calls

Emergency calls from an extension are not blocked even if SRTP is required but cannot be established.

Calls using SRTP do not use any special indication on the user's telephone. Normal call functions (conference, transfer, etc) remain available to the user. SRTP alarms and details of when SRTP is being used are shown by the System Status Application and System Monitor.

## Related links

[Security Administration](#) on page 113

# Chapter 8: Editing IP Office Security Settings in Manager

The following conditions apply when editing the IP Office security settings.

- Editing of security settings may only be done online to a system.  
No offline saving or editing is allowed for security purposes.
- No errors in the security settings are allowed to persist.  
This prevents the system becoming inaccessible through operator error.
- Sets of changes to security objects may be made without the need for the OK button to be selected every time.  
This allows a coordinated set of changes to be accepted or canceled by the operator.

---

## Loading Security Settings

### About this task

The address ranges in which Manager searches for systems are set through the Manager preferences (File | Preferences | Discovery). The security mechanism used for security settings transfer between Manager and a system are set through the Secure Communications attribute of Manager preferences (**File | Preferences | Security**).

If not already done, switch Manager to security mode by selecting **File | Advanced | Security Settings**.

### \* Note:

If the system's configuration settings have already been loaded using a service user name and Password that also has security access, then the security settings are automatically loaded when Manager is switched to security mode.

### Procedure

1. If already in security mode, click  in the main toolbar or select **File | Open Security Settings** from the menu bar.
2. The Select IP Office window appears, listing those systems that responded.  
The list can be sorted by clicking on the column names.

3. If the system required was not found, the address used for the search can be changed.

Enter or select the required address in the **Unit/Broadcast Address** field and then click Refresh to perform a new search.

4. When the system required is located, check the box next to the system and click **OK**.

5. The user name and password request for the system is then displayed.

Enter the required details and click **OK**. By default this is a different user name and password from those that can be used for configuration access.

6. If the security settings are received successfully, they appear within Manager.

- If the service user name/password is incorrect, or the service user has insufficient rights to read the security settings, "**Access Denied**" is displayed.
- If the network link fails, or the secure communication mode is incorrect (for example Manager is set to unsecured, but the system is set to secure only), "**Failed to communicate with IP Office**" is displayed.

---

## Saving Security Settings

### About this task Procedure

1. Click  in the **Main Toolbar** or select **File | Save Security Settings** from the menu bar. These options are only available when some change has been made.
2. The user name and password request for the system is then displayed.

Enter the required details and click **OK**. By default this is a different user name and password from those that can be used for configuration access.

---

## Resetting a System's Security Settings

### About this task Procedure

1. Select **File | Reset Security Settings** (if in security mode), or **File | Advanced | Erase Security Settings** (if in configuration mode).
2. The Select IP Office window appears, listing those systems that responded.  
The list can be sorted by clicking on the column names.
3. When the system required is located, check the box next to the system and click **OK**.
4. The user name and password request for the system is then displayed.



Enter the required details and click **OK**. By default this is a different user name and password from those that can be used for configuration access.

5. Manager will indicate if the security settings are reset successfully.

# Chapter 9: Security Mode Field Descriptions







The Manager Security Mode is used to load and edit the security settings of a system. How the controls operate is similar to Manager in configuration mode.

To switch to Security Mode, select **File | Advanced | Security Settings**.





To switch back to Configuration Mode, select **File | Configuration**.

## Security Mode Screen Elements

**Table 2: Toolbar icons**

Icon	Action
	Get the Security Settings
	Save the Security Settings
	Not Used in security mode
	Show/Hide the Navigation Pane
	Show/Hide the Group Pane
	Not used in security mode
	Not used in security mode

**Security Settings Pane:** This pane is used to select the type of security records that should be displayed in the group pane or details pane.

-  **General** Defines general security controls for the system. When selected, the settings are displayed in the details pane.
-  **System** Defines security settings for the system such as application access. When selected, the settings are displayed in the details pane.
-  **Services** Secure services supported by the system. Currently these are access to security settings and access to configuration settings.
-  **Rights Groups** Create groups with different access rights. When selected, the existing Rights Groups are displayed in the group pane.

- 
**Service Users** Sets the name and password for an administrator. Also allows selection of the Rights Groups to which the user belongs. When selected, the existing service users are displayed in the group pane.

**Group Pane:** This pane is used to display the existing Right Groups or Service Users when those options are selected in the security settings pane.

**Details Pane:** This pane shows the settings selected in the security settings pane or the group pane.

**Status Bar:** This bar display messages about communications between Manager and systems. It also displays the security level of the communications by the use of a padlock icon.

#### Related links

- [General Security Settings](#) on page 139
- [System](#) on page 145
- [Security Services Settings](#) on page 154
- [Rights Groups](#) on page 156
- [Service Users](#) on page 162

---

## General Security Settings

#### Related links

- [Security Mode Field Descriptions](#) on page 138
- [General](#) on page 139

---

## General

Field	Description
<b>Security Administrator</b>	The Security Administrator is a special service user who does not belong to any <b>Rights Groups</b> . The Security Administrator is able to access the system's security settings but cannot access its configuration settings. By default they are the only service user able to access to the security settings.
<b>Unique Security Administrator</b>	Default = Off When selected, only the Security Administrator is able to access the system's security settings. When this is selected, the security options for Rights Groups are disabled. When not selected, the ability to access security settings can also be assigned to Rights Groups.
<b>Name:</b>	Default = 'security'. Range = 6 to 31 characters. The name for the Security Administrator.

*Table continues...*

Field	Description
<b>Password</b>	<p>Default = 'securitypwd'. Range = 9 to 31 characters.</p> <p>The password for the Security Administrator. In order to change the Security Administrator password, the current password must be known.</p>
<b>Minimum Password Complexity</b>	<p>Default = Medium.</p> <p>The password complexity requirements for the Security Administrator. This setting is active for attempted password changes on both Security Manager and the system. The options are:</p> <p><b>Low:</b></p> <p>Any password characters may be used without constraint.</p> <p><b>Medium:</b></p> <p>The password characters used must include characters from at least 2 of the 'code point sets' listed below. For example a mix of lower case and upper case. In addition, 3 or more consecutive identical characters of any type is not allowed.</p> <p><b>High:</b></p> <p>The password characters used must include characters from at least 3 of the 'code point sets' listed below. For example a mix of lower case, upper case and numbers. In addition, 3 or more consecutive identical characters of any type is not allowed.</p> <p><b>Code Point Sets:</b></p> <ul style="list-style-type: none"> <li>• Lower case alphabetic characters.</li> <li>• Upper case alphabetical character.</li> <li>• Numeric characters.</li> <li>• Non-alphanumeric characters, for example # or *.</li> </ul> <p> <b>Note:</b></p> <p>Password must not contain your user name.</p>
<b>Previous Password Limit (Entries)</b>	<p>Default = 10. Range = 0 (Off) to 24 records.</p> <p>The number of previous password to check for duplicates against when changing the password. When set to <b>0</b>, no checking of previous passwords takes place. This setting is active for attempted password changes on both Security Manager and the system.</p>
<b>Phone Registration</b>	
<b>Block Default IP Phone Passcodes</b>	<p>Default: New systems: Checked, Upgraded systems: Clear</p> <p>If selected, existing IP phone registrations with default passcodes are not allowed in the system. Administrators must type in passwords for registering the existing phones. If not checked, existing IP phone registrations with default passcodes are allowed for registration with the system. Allowing existing phones to register with default passcodes pose a security risk as outsiders can access the system using those passcodes.</p>

*Table continues...*

Field	Description
<b>Service User Details</b>	
These settings control service user names and password/account policies. This setting is active for attempted password changes on all administration interfaces.	
<b>Minimum Name Length</b>	Default = 6, Range 1 to 31 characters. This field sets the minimum name length for service user names.
<b>Minimum Password Length</b>	Default = 9, Range 1 to 31 characters. This field sets the minimum password length for service user passwords.
<b>Password Reject Limit</b>	Default = 3, Range 0 to 255 failures. Sets how many times an invalid name or password is allowed within a 10 minute period before the Password Reject Action is performed. Selecting 0 indicates never perform the <b>Password Reject Action</b> .
<b>Password Reject Action</b>	Default = Log and Temporary Disable. The action performed when a user reaches the <b>Password Reject Limit</b> . The options are: <ul style="list-style-type: none"> <li>• <b>No Action</b></li> <li>• <b>Log to Audit Trail</b> Log to Audit Trail creates a record indicating the service user account name and time of last failure.</li> <li>• <b>Log and Disable Account:</b> Log and Disable Account creates an audit trail record and additionally permanently disables the service user account. This account can only be enabled using the Security Manager Service User settings.</li> <li>• <b>Log and Temporary Disable:</b> Log and Temporary Disable creates an audit trail record and additionally temporarily disables the service user account for 60 seconds. This account can only be enabled using the Security Manager Service User settings.</li> </ul>

*Table continues...*

Field	Description
<p><b>Minimum Password Complexity</b></p>	<p>Default = Medium.</p> <p>The password complexity requirements for the Security Administrator. This setting is active for attempted password changes on both Security Manager and the system. The options are:</p> <p><b>Low:</b></p> <p>Any password characters may be used without constraint.</p> <p><b>Medium:</b></p> <p>The password characters used must include characters from at least 2 of the 'code point sets' listed below. For example a mix of lower case and upper case. In addition, 3 or more consecutive identical characters of any type is not allowed.</p> <p><b>High:</b></p> <p>The password characters used must include characters from at least 3 of the 'code point sets' listed below. For example a mix of lower case, upper case and numbers. In addition, 3 or more consecutive identical characters of any type is not allowed.</p> <p><b>Code Point Sets:</b></p> <ul style="list-style-type: none"> <li>• Lower case alphabetic characters.</li> <li>• Upper case alphabetical character.</li> <li>• Numeric characters.</li> <li>• Non-alphanumeric characters, for example # or *.</li> </ul> <p> <b>Note:</b></p> <p>Password must not contain your user name.</p>
<p><b>Previous Password Limit (Entries)</b></p>	<p>Default = 10. Range = 0 (Off) to 10 records.</p> <p>The number of previous password to check for duplicates against when changing the password. When set to <b>0</b>, no checking of previous passwords takes place. This setting is active for attempted password changes on both Security Manager and the system.</p>
<p><b>Password Change Period</b></p>	<p>Default = 0 (Off). Range 0 to 999 days.</p> <p>Sets how many days a newly changed password is valid. Selecting 0 indicates any password is valid forever. This setting is active for password changes through this form or prompted by Manager. Note that the user must be a member of a Rights Group that has the Security Administration option <b>Write own service user password</b> enabled. If this timer expires, the service user account is locked. The account may only be re-enabled using the Service User Settings. To prompt the user a number of days before the account is locked set a Expiry Reminder Time (see below).</p> <p>Whenever this setting is changed and the OK button is clicked, the Security Manager recalculates all existing service user password timers.</p>

*Table continues...*

Field	Description
<b>Account Idle Time</b>	<p>Default = 0 (Off). Range 0 to 999 days.</p> <p>Sets how many days a service user account may be inactive before it becomes disabled. Selecting 0 indicates an account may be idle forever. If this timer expires, the service user account is permanently disabled. The account may only be re-enabled using the Service User Settings. The idle timer is reset whenever a service user successfully logs in.</p> <p>Whenever this setting is changed and the OK button is clicked, the Security Manager recalculates all existing service user idle timers.</p>
<b>Expiry Reminder Time</b>	<p>Default = 10. Range 0 (Off) to 999 days.</p> <p>Sets the period before password or account expiry during which a reminder indication if the service user logs in. Selecting 0 prevents any reminders. Reminders are sent, for password expiry due to the <b>Password Change Period</b> (above) or due to the Account Expiry date (see <a href="#">Service User Settings</a> on page 162) – whichever is the sooner. Currently Manager displays reminders but System Status does not.</p>
<b>IP Office User Details</b>	
These settings control IP Office user password/account policies.	
<b>Password Enforcement</b>	<p>Default = On.</p> <p>When enabled, password settings are enforced. When disabled, password requirements are not enforced and the remaining settings are not editable</p>
<b>Minimum Password Length</b>	<p>Default = 9, Range 1 to 31 characters.</p> <p>This field sets the minimum password length for user passwords</p>

*Table continues...*

Field	Description
<b>Minimum Password Complexity</b>	<p>Default = Medium.</p> <p>The password complexity requirements for the Security Administrator. This setting is active for attempted password changes on both Security Manager and the system. The options are:</p> <p><b>Low:</b></p> <p>Any password characters may be used without constraint.</p> <p><b>Medium:</b></p> <p>The password characters used must include characters from at least 2 of the 'code point sets' listed below. For example a mix of lower case and upper case. In addition, 3 or more consecutive identical characters of any type is not allowed.</p> <p><b>High:</b></p> <p>The password characters used must include characters from at least 3 of the 'code point sets' listed below. For example a mix of lower case, upper case and numbers. In addition, 3 or more consecutive identical characters of any type is not allowed.</p> <p><b>Code Point Sets:</b></p> <ul style="list-style-type: none"> <li>• Lower case alphabetic characters.</li> <li>• Upper case alphabetical character.</li> <li>• Numeric characters.</li> <li>• Non-alphanumeric characters, for example # or *.</li> </ul> <p> <b>Note:</b></p> <p>Password must not contain your user name.</p>
<b>Password Reject Limit</b>	<p>Default = 5, Range 0 to 255 failures.</p> <p>Sets how many times an invalid name or password is allowed within a 10 minute period before the Password Reject Action is performed. Selecting 0 indicates never perform the <b>Password Reject Action</b>.</p>
<b>Password Reject Action</b>	<p>Default = Log and Temporary Disable. The action performed when a user reaches the <b>Password Reject Limit</b>. The options are:</p> <ul style="list-style-type: none"> <li>• <b>No Action</b></li> <li>• <b>Log to Audit Trail</b> creates a record indicating the user account name and time of last failure.</li> <li>• <b>Log and Disable Account</b> creates an audit trail record and additionally permanently disables the user account. The account can be enabled using the <b>Account Status</b> field on the <b>User &gt; User</b> page.</li> <li>• <b>Log and Temporary Disable</b> creates an audit trail record and additionally temporarily disables the user account for 60 seconds. The account can be enabled using the <b>Account Status</b> field on the <b>User &gt; User</b> page.</li> </ul>

**Related links**

[General Security Settings](#) on page 139



# System

## Related links

[Security Mode Field Descriptions](#) on page 138

[System Details](#) on page 145

[Unsecured Interfaces](#) on page 147

[Certificates](#) on page 148

## System Details

Field	Description
<b>Base Configuration</b>	
<b>Services Base TCP Port</b>	<p>Default = 50804. Range = 49152 to 65526.</p> <p>This is the base TCP port for services provided by the system. It sets the ports on which the system listens for requests to access those services, using its LAN1 IP address. Each service uses a port offset from the base port value. If this value is changed from its default, the Manager application must be set to the same Base TCP Port through its Services Base TCP Port setting (File   Preferences).</p> <p>For information on port usage see the IP Office Port Matrix document on the Avaya support site at <a href="https://support.avaya.com/helpcenter/getGenericDetails?detailId=C201082074362003">https://support.avaya.com/helpcenter/getGenericDetails?detailId=C201082074362003</a></p>
<b>Maximum Service Users</b>	<p>Default = 64.</p> <p>This is a fixed value for indication purposes only. This value is the maximum number of service users that can be stored in a system's security settings</p>
<b>Maximum Rights Groups</b>	<p>Default = 32.</p> <p>This is a fixed value for indication purposes only. This value is the maximum number of Rights Groups that can be stored in a system's security settings.</p>
<b>System Discovery</b>	
<p>System discovery is the processes used by applications to locate and list available systems. The IP Office can be disabled from responding to this process if required. If this is done, access to the IP Office requires its specific IP address to be used.</p>	
<b>TCP Discovery Active</b>	<p>Default = On.</p> <p>Selecting TCP Discovery Active allows the system to respond to those requests.</p>
<b>UDP Discovery Active</b>	<p>Default = On.</p> <p>Selecting UDP Discovery Active allows the system to respond to those requests.</p>
<b>Security</b>	
<p>These settings cover the per-system security aspects, primarily TLS settings.</p>	

*Table continues...*

Field	Description
<b>Session ID Cache</b>	<p>Default = 10 hours, Range 0 to 100 hours.</p> <p>This sets how long a TLS session ID is retained by the system. If retained, the session ID may be used to quickly restart TLS communications between the system and a re-connecting application. When set to <b>0</b>, no caching takes place and each TLS connection must be renegotiated.</p>
<b>HTTP Challenge Timeout (Seconds)</b>	<p>Default = 10.</p> <p>For HTTP/HTTPS connection attempts, this field sets the timeout for connection validation responses.</p>
<b>RFC2617 Session Cache (Minutes)</b>	<p>Default = 10.</p> <p>For HTTP/HTTPS sessions, this field sets the allowed duration for successful logins as per RFC2617.</p>
<b>Minimum Protocol Version</b>	<p>Default = TLS 1.0</p> <p>This sets the TLS protocol version to be used in case of a TLS connection. If selected, the TLS servers allow connections that meet the specified minimum requirement of the selected protocol version and connections from a lower TLS version fails.</p>
<b>HTTP Ports</b>	
These settings set the ports for web based configuration access to the system.	
<b>HTTP Port</b>	Default = 80.
<b>HTTPS Port</b>	Default = 443.
<b>Web Services Port</b>	Default =8443.
<b>WebSocket Proxy</b>	
These settings are applicable to WebSocket communication over IP Office lines.	
<b>Enabled</b>	<p>Default = On.</p> <p>When set to On , Web Manager uses the proxy server to communicate between the Server Edition Primaryserver and other nodes.</p> <p>When set to Off, the WebSocket proxy is disabled. Any IP Office line WebSocket communication over an HTTP session is closed with “404 NotFound”.</p>
<b>Enforce Secure</b>	<p>Default = On.</p> <p>Applicable only when the <b>Enabled</b> check box is On.</p> <p>When set to On, any proxy communication over IP Office line Websocket uses HTTPS.</p> <p>When set to Off, any HTTPS communication over IP Office line Websocket is disallowed and the session is closed with “403 Forbidden”.</p>
<b>Avaya Spaces API Key</b>	The API Key from Avaya Spaces. Use the Eye icon to view the key. To obtain the key, log on to the Avaya Spaces account and browse to <b>Zang Account &gt; Manage Companies &gt; Company Profile &gt; API Key &gt; API Key</b> .
<b>Avaya Spaces Key Secret</b>	The key secret from Avaya Spaces account. Use the Eye icon to view the key. To obtain the key secret, log on to the Avaya Spaces account and browse to <b>Zang Account &gt; Manage Companies &gt; Company Profile &gt; API Key &gt; View/Edit &gt; Secret</b> .

## Related links

[System](#) on page 145

## Unsecured Interfaces

These features relate to applications that access the system configuration settings using older security methods.

Field	Description
<b>System Password</b>	<p>Default = 'password'. Range = 0 to 31 characters.</p> <p>The system password is used by IP Office Manager to upgrade IP Office IP500 V2 systems. Also used for Monitor when the Monitor password setting is blank.</p>
<b>Voicemail Password</b>	<p>Default = Blank. Range = exactly 31 characters.</p> <p>For IP Office 11.1 FP1 and higher versions, the password for voicemail connection is enforced to 31 characters.</p> <p>This password is also set through the Voicemail Pro client and Web Manager application.</p> <p>When no password is set, an auto generated password is automatically set on both Voicemail Pro client and Web Manager systems.</p>
<b>Monitor Password</b>	<p>Default = Blank. Range = 0 to 31 characters.</p> <p>This password, if set, is used by the System Monitor application. If this password is not set, those applications use the system password. If changing this password with no previous password set, enter the system password as the old password.</p>
<b>Use Service User Credentials</b>	<p>Default = Off.</p> <p>Set to <b>On</b> to enable log in to the System Monitor application using the service user credentials.</p>
<b>Applications Controls</b>	<p>These check boxes control which actions the system will support for legacy applications. Different combinations are used by the different applications. A summary of the applications affected by changes is listed in the <b>Application Support</b> list.</p> <ul style="list-style-type: none"> <li>• <b>TFTP Server</b>: Default = On.</li> <li>• <b>TFTP Directory Read</b>: Default = Off.</li> <li>• <b>TFTP Voicemail</b>: Default = Off.</li> <li>• <b>Program Code</b>: Default = On.</li> <li>• <b>DevLink</b>: Default = On.</li> <li>• <b>TAPI/DevLink3</b>: Default = Off.</li> <li>• <b>HTTP Directory Read</b>: Default = On. Allow the system's current directory records to be accessed using HTTP.</li> <li>• <b>HTTP Directory Write</b>: Default = On. Allow HTTP import to be used to place temporary directory records into the directory.</li> </ul>

*Table continues...*

Field	Description
<b>Application Support</b>	This panel is shown for information only. It indicates the effect on various applications of the Application Controls selections.

### Related links

[System](#) on page 145

## Certificates

### Additional Configuration Information

For additional information on certificates, see [Certificate Management](#) on page 581.

Services between the system and applications may, depending on the settings of the service being used for the connection, require the exchange of security certificates. The system can either generate its own certificate or certificates provided from a trusted source can be loaded.

#### **Warning:**

The process of 'on-boarding' (see *Deploying Avaya IP Office™ Platform SSL VPN Services*) automatically adds a certificate for the SSL VPN to the system's security settings when the on-boarding file is uploaded to the system. Care should be taken not to delete such certificates except when advised by Avaya.

### Configuration Settings

Field	Description
<b>Identity Certificate:</b>	<p>The <b>Identity Certificate</b> is an X.509v3 certificate that identifies the system to a connecting another device using TLS, for example a PC running IP Office Manager set to Secure Communications.</p> <p>By default, the system provides its own self-generated certificate, automatically generated when the system is first installed. Alternatively, a certificate from another source can be uploaded to the system if required.</p> <p>The system's certificate is advertised (used) by Services which have their <b>Service Security Level</b> set to a value other than <b>Unsecure Only</b>.</p>
<b>Offer Certificate</b>	<p>Default = On.</p> <p>This is a fixed value for indication purposes only. This sets whether the system will offer a certificate in the TLS exchange when the IP Office is acting as a TLS server, which occurs when accessing a secured service.</p>

*Table continues...*

Field	Description
<b>Offer ID Certificate Chain</b>	<p>Default = Off.</p> <p>When set to On, this setting instructs IP Office to advertise a chain of certificates in the TLS session establishment. The chain of certificates is built starting with the identity certificate and adding to the chain all certificates it can find in the IP Office Trusted Certificate Store based on the Common Name found in the "Issued By" Subject Distinguished Name field in each of the certificates in the chain. If the Root CA certificate is found in the IP Office Trusted Certificate Store, it will be included in the chain of certificates. A maximum of six certificates are supported in the advertised chain of certificates.</p>
<b>Issued to</b>	<p>Default = IP Office identity certificate.</p> <p>Common name of issuer in the certificate.</p>
<b>Set</b>	<p>This option can is used to load a certificate and associated private key. The certificate and key must be a matching pair.</p> <p>IP Office supports certificates with RSA key sizes of 1024, 2048 and 4096 bits. The use of RSA key size 4096 may impact system performance. The recommended key size is 2048.</p> <p>IP Office supports signature algorithms of SHA-1, SHA-256, SHA-384, and SHA-512. Using signature size larger than SHA-256 may impact system performance. The recommended signature algorithm is SHA-256.</p> <p>The source may be:</p> <ul style="list-style-type: none"> <li>• Current User Certificate Store.</li> <li>• Local Machine Certificate Store.</li> <li>• File in the PKCS#12 (.pfx) format</li> <li>• Pasted from clipboard in PEM format, including header and footer text.</li> </ul> <p>This method must be used for PEM (.cer) and password protected PEM (.cer) files. The identity certificate requires both the certificate and private key. The .cer format does not contain the private key. For these file types select <b>Paste from clipboard</b> and then copy the certificate text and private key text into the Certificate Text Capture window.</p> <p><b>Using a file as the certificate source:</b></p> <p>In Manager, when using the file option, the imported "p12" "pfx" or "cer" file for setting the identity certificate can only contain the private key and identity certificate data. It cannot contain additional Intermediate CA certificates or the Root CA certificate. The Intermediate CA certificates or the Root CA certificate must be imported separately in the IP Office Trusted Certificate Store.</p> <p>This does not apply to Web Manager.</p> <p> <b>Note:</b></p> <p>Web Manager does not accept the file of type "cer" with extension ".cer". This file type can only be used in Manager.</p>

*Table continues...*

Field	Description
<b>View</b>	<p>This command displays details of the current identity certificate. The certificate source, details and valid dates are displayed.</p> <p>The certificate view menu can also be used to install the certificate (but not its private key) into the viewing PC's local certificate store for use by the PC for secure connection to the system or to export the certificate from the PC.</p>

*Table continues...*

Field	Description
<b>Regenerate</b>	<p>This command deletes the current identity certificate and generates a new self-signed certificate.</p> <p><b>!</b> <b>Important:</b></p> <p>Regenerating the certificate can take up to a minute during which system performance may be impacted. Therefore it is recommended to only perform this action during a maintenance window. The regeneration takes places after saving the changes to security settings.</p> <p>Clicking <b>Regenerate</b> opens the Regenerate Certificate window where you are prompted to enter the following information:</p> <ul style="list-style-type: none"> <li>• <b>Signature:</b> Default = SHA256/RSA2048.</li> </ul> <p>This setting configures both the signature algorithm and the RSA key length to use when generating the IP Office identity certificate. The options are:</p> <ul style="list-style-type: none"> <li>- SHA256/RSA2048</li> <li>- SHA1/RSA1024</li> </ul> <p>If any other combinations are needed, the Security Administrator will need to construct the IP Office identity certificate outside of Manager and use the <b>Set</b> action to install it.</p> <ul style="list-style-type: none"> <li>• <b>Default Subject Name:</b></li> </ul> <p>Default = Blank</p> <p>Specifies a common name for the subject of this certificate. The subject is the end-entity or system that owns the certificate (public key). Example: ipoffice-0123456789AB.avaya.com.</p> <p>If the field is blank, a system generated subject name is used.</p> <ul style="list-style-type: none"> <li>• <b>Subject Alternative Name(s):</b></li> </ul> <p>Default = Blank</p> <p>The Subject Alternative Name (SAN) field allows a list of alternate names to be bound to the subject of the certificate.</p> <p>The input field will allow the user to enter multiple Subject Alternate Names, each separated by the comma “,” character. Each SAN consists of a PREFIX, followed by the colon “:” character, followed by VALUE. The list of allowed PREFIX strings are “DNS”, “URI”, “IP”, “SRV”, and “email”. The VALUE can be any text character except the comma. (The comma is reserved as a field separator.) The input field has a maximum size limit of 511 characters.</p> <p><b>Example:</b> “DNS: ipoffice-0123456789AB.avaya.com, IP: 192.168.137.29, URI:http://avaya_example_url.com/, email:jack@my_email_server.com”</p> <p>Supported Subject Alternative Name types include: a DNS Name, a Uniform Resource Identifier, an IP Address, an SRV record, or an electronic mail address.</p>

*Table continues...*

Field	Description
	<p>Although a PREFIX must be specified to select the type of name, no validation is performed on the value.</p> <p>If this field is blank, a system-generated subject alternative name field value is used.</p>
<b>Automatic Certificate Management</b>	<p>Default = Disabled</p> <p>It is enabled by default on new deployments of Subscription CPE systems. The feature is designed for Subscription systems only.</p> <p>When this setting is enabled, the system obtains its identity certificate signed by the <b>Deployment Root CA</b>. The maintenance and renewal of this certificate and its trust chain are performed automatically.</p>
<b>Automatic Phone Provisioning</b>	<p>Default = Enabled</p> <p><b>Automatic Certificate Management</b> setting should be enabled.</p> <p>Updates phone certificates automatically when the system certificates change.</p>
<b>Certificate Expiry Warning Days</b>	<p>Default = 60, Range = 30 to 180</p> <p>IP Office Manager can display a warning when a system's security certificate is due to expire. This setting is used to set the trigger for certificate warnings.</p>
<b>Use Different Identity Certificate for SIP Telephony</b>	<p>Default = None</p> <p>The possible settings are <b>None</b>, <b>SIP Trunks</b> or <b>SIP &amp; SM Trunks, SIP Phones</b>.</p> <p>When set to <b>None</b>, all secure telephony communications use the system's default identity certificate and settings.</p> <p>When enabled, an extra set of options similar to those shown for <b>Identity Certificate</b> section are displayed. These can be used to define the certificate used for secure telephony communications. The certificate to use is uploaded to the system's certificate store using the <b>Set</b> button.</p>
<b>Received Certificate Checks (Management Interface)</b>	<p>Default = None.</p> <p>This setting is used for administration connections to the system by applications such as Manager. When the <b>Service Security Level</b> of the service being used is set to <b>High</b>, a certificate is requested by the system. The received certificate is tested as follows:</p> <ul style="list-style-type: none"> <li>• <b>None:</b> No extra checks are made (The certificate must be in date).</li> <li>• <b>Low:</b> Certificate minimum key size 1024 bits, in date.</li> <li>• <b>Medium:</b> Certificate minimum key size 1024 bits, in date, match to store.</li> <li>• <b>High:</b> Certificate minimum key size 2048 bits, in date, match to store, no self signed, no reflected, chain validation.</li> </ul>

*Table continues...*



Field	Description
<b>Received Certificate Checks (Telephony Endpoints)</b>	<p>Default = None.</p> <p>This setting is used with IP telephony endpoints connecting to the system.</p> <p>This setting is used by IP Office to validate the identity certificate offered by the other end of TLS connection. IP Office does not support mutual authentication for SIP phones (an identity certificate is not installed in all SIP phones). Therefore, IP Office does not require a client certificate from a SIP phone, only SIP/SM trunks.</p> <p>The received certificate is tested as follows:</p> <ul style="list-style-type: none"> <li>• <b>None:</b> No extra checks are made (The certificate must be in date).</li> <li>• <b>Low:</b> Certificate minimum key size 1024 bits, in date.</li> <li>• <b>Medium:</b> Certificate minimum key size 1024 bits, in date, match to store.</li> <li>• <b>High:</b> Certificate minimum key size 2048 bits, in date, match to store, no self signed, no reflected, chain validation.</li> </ul>
<p><b>Trusted Certificate Store</b></p> <p>This section displays a list of the certificates held in the system's trusted certificate store.</p>	
<b>Installed Certificates</b>	<p>Default = A set of fixed Avaya provided Intermediate CA or Root CA certificates.</p> <p>The certificate store contains a set of trusted certificates used to evaluate received client certificates. Up to 25 X.509v3 certificates may be installed.</p>
<b>Add</b>	<p>Add a trusted certificate. The source may be:</p> <ul style="list-style-type: none"> <li>• Current User Certificate Store.</li> <li>• Local Machine Certificate Store.</li> <li>• File in one of the following formats: <ul style="list-style-type: none"> <li>- PEM (.cer)</li> <li>- password protected PEM (.cer)</li> <li>- DER (.cer)</li> <li>- password protected DER (.cer)</li> </ul> </li> <li>• Pasted from clipboard in PEM format, including header and footer text.</li> </ul> <p>This method must be used for PKCS#12 (.pfx) files. The PKCS#12 (.pfx) format contains a private key and a trusted certificate cannot contain a private key. For this file type, select <b>Paste from clipboard</b> and then copy the certificate text into the Certificate Text Capture window.</p> <p>IP Office supports certificates with RSA key sizes of 1024, 2048 and 4096 bits. The use of RSA key size 4096 may impact system performance. The recommended key size is 2048.</p> <p>IP Office supports signature algorithms of SHA-1, SHA-256, SHA-384, and SHA-512. Using signature size larger than SHA-256 may impact system performance. The recommended signature algorithm is SHA-256.</p>

*Table continues...*

<b>View</b>	View the currently selected certificate. The certificate (not the private key) may also be installed into the local PC certificate store for export or later use when running the manager in secured mode.
<b>Delete</b>	Delete the currently selected certificate.

<b>SCEP Settings</b>	
<p>The Simple Certificate Enrollment Protocol is a protocol intended to ease the issuing of certificates in a network where numerous devices are using certificates. Rather than having to individually administer the certificate being used by each device, the devices can be configured to request a certificate using SCEP.</p> <p>These settings are relevant for IP Office Branch deployments.</p> <p>These settings are not used in IP Office Standard mode.</p>	
<b>Active</b>	Default = Off.
<b>Request Interval (seconds)</b>	Default = 120 seconds. Range = 5 to 3600 seconds.
<b>SCEP Server IP/ Name</b>	Default = Blank.
<b>SCEP Server Port</b>	Default = 80 for HTTP and 443 for HTTPS.
<b>SCEP URI</b>	Default = /ejbca/publicweb/apply/scep/pkclient.exe
<b>SCEP Password</b>	Default = Blank.

**Related links**

[System](#) on page 145



---

## Security Services Settings

This tab shows details of the services that the system runs to which service users can communicate.

Field	Description
<b>Name</b>	The name of the service. This is a fixed value for indication purposes only.
<b>Host System</b>	This field shows the system's name. This is a fixed value for indication purposes only.
<b>Service Port</b>	<p>This is the port on which the system listens for attempts to access the service. The routing of traffic to this port may need to be enabled on firewalls and network devices between the service users and the system. The base port (TCP or HTTP) for each service is offset by a fixed amount from the ports set in System Settings.</p> <p>For information on port usage see the IP Office Port Matrix document on the Avaya support site at <a href="https://support.avaya.com/helpcenter/getGenericDetails?detailId=C201082074362003">https://support.avaya.com/helpcenter/getGenericDetails?detailId=C201082074362003</a></p>

*Table continues...*

Field	Description
<b>Service Security Level</b>	<p>Sets the minimum security level the service will support. See <b>File   Preferences   Security</b> for the corresponding Manager application setting, which must be changed to match the appropriate service access security settings.</p> <p> <b>Warning:</b></p> <p>If the system does not already have an X509 security certificate, selecting a setting other than <b>Unsecure Only</b> will cause the system to stop responding for a period (less than a minute) while the system generates its own unique security certificate.</p> <p>The options are:</p> <ul style="list-style-type: none"> <li>• <b>Unsecure Only</b> This option allows only unsecured access to the service. The service's secure TCP port, if any, is disabled. This or disabled are the only options supported for the System Status Interface and Enhanced TSPI services.</li> <li>• <b>Unsecure + Secure</b> This option allows both unsecured and secure (Low) access. In addition, TLS connections are accepted without encryption, just authentication.</li> <li>• <b>Secure, Low</b> This option allows secure access to that service using TLS, and demands weak (for example DES_40 + MD5) encryption and authentication or higher. The service's unsecured TCP port is disabled.</li> <li>• <b>Secure, Medium</b> This option allows secure access to that service using TLS, and demands moderate (for example SHA-256) encryption and authentication or higher. The service's unsecured TCP port is disabled.</li> <li>• <b>Secure, High</b> This option allows secure access to that service using TLS and demands strong (for example SHA-256) encryption and authentication, or higher. In addition, a certificate is required from the client (usually Manager). See System Details   Client Certificate Checks for tests made on the received certificate. The service's unsecured TCP port is disabled.</li> <li>• <b>Disabled</b> This option is available for the System Status Interface and Enhanced TSPI services. If selected, access to the service is disabled.</li> </ul>
<b>Service Access Source</b>	<p>For Server Edition systems, it is defaulted to <b>Server Edition Manager</b>. When set to <b>Server Edition Manager</b>, the system can only be configured using Manager in its Server Edition mode. When set to <b>Unrestricted</b>, the system can be configured using Manager in its normal Simplified View or Advanced View modes.</p> <p> <b>Warning:</b></p> <p>Opening the configuration of a Server Edition system in Manager running in any mode other than Server Edition mode should be avoided unless absolutely necessary for system recovery. Even in that case, Manager will not allow renumbering, changes to the voicemail type and changes to H.323 lines.</p> <p>For systems centrally managed using SMGR, it is defaulted to <b>Avaya Aura System Manager</b>. When set to <b>Avaya Aura System Manager</b>, the system can only be configured using SMGR in Branch Mode. When set to <b>Unrestricted</b>, the system can be configured using Manager in its normal Simplified View or Advanced View modes.</p>

### Related links

[Security Mode Field Descriptions](#) on page 138

# Rights Groups

## Related links

- [Security Mode Field Descriptions](#) on page 138
- [Group Details](#) on page 156
- [Configuration](#) on page 156
- [Security Administration](#) on page 158
- [System Status](#) on page 158
- [Telephony APIs](#) on page 159
- [HTTP](#) on page 159
- [Web Services](#) on page 159
- [External](#) on page 161

## Group Details

This tab sets the name of the Rights Group.

Field	Description
<b>Name</b>	: Range = Up to 31 characters  The name for the Rights Group should be unique. The maximum number of rights groups is 32.

## Related links

- [Rights Groups](#) on page 156

## Configuration

This tab sets the configuration settings access for service user's who are members of this Rights Group.

Field	Description		
<b>IP Office Service Rights</b>	This setting controls what action on the system can be performed by members of the Rights Group.		
<b>Manager Operator Rights</b>	This setting controls what types of configuration records Manager will allow members of the Rights Group to viewed and what actions they can perform with those types of records. The <b>Administrator</b> and <b>Manager</b> rights group members are also able to access embedded file management.		
	<b>Operator</b>	<b>View/Edit/ New/Delete</b>	<b>Configuration Record Types</b>
	<b>Administrator</b>	All	View, edit create and delete all configuration records.

*Table continues...*

Field	Description		
	<b>Manager</b>	View	View all except WAN Port.
		Edit	Extension, User, Hunt Group, Short Code, Service, RAS, Incoming Call Route, Directory, Time Profile, Firewall Profile, IP Route, Least Cost Route, Account Code, ARS.
		New	
		Delete	As edit except Short Code.
	<b>Operator</b>	View	View all except WAN Port.
		Edit	Extension, User, Hunt Group, Short Code, Service, RAS, Incoming Call Route, Time Profile, Firewall Profile, IP Route, Least Cost Route, Account Code, License, ARS.
		New	None.
		Delete	Delete Incoming Call Route and Directory.
	<b>User &amp; Group Edit</b>	View	User and Hunt Group records only.
		Edit	
		New	None
		Delete	
	<b>User &amp; Group Admin</b>	All	User and Hunt Group records only.
	<b>Dir &amp; Account Admin</b>	All	Directory and Account Code records only.
	<b>Time &amp; Attendant Admin</b>	All	Time Profile and Auto Attendant records only.
	<b>ICR &amp; User Rights Admin</b>	All	Incoming Call Route and User Rights records only.
	<b>Read Only</b>	View	View all configuration records.
		Edit	None.
		New	
		Delete	

**Related links**

[Rights Groups](#) on page 156

---

## Security Administration

This tab sets the security settings access for Service user's who are members of this Rights Group. These settings are ignored and greyed out if a Unique Security Administrator has been enabled in General Settings.

Field	Description
<b>Read all security settings</b>	Members of the Rights Group can view the system's security settings.
<b>Write all security settings</b>	Members of the Rights Group can edit and return changes to the system's security settings.
<b>Reset all security settings</b>	If selected, members of the Rights Group can reset the security settings to default values.
<b>Write own service user password</b>	If selected, members of the Rights Group can change their own password when requested to do so by the system. That request may be the result of a Password Change Period, Force new password or Account Expiry. The new password change is requested automatically at login time.

### Related links

[Rights Groups](#) on page 156

---

## System Status

This tab sets whether members of the group can access the system using the System Status Application (SSA).

Field	Description
<b>System Status Access</b>	If selected, members of the Rights Group can view the system's current status and resources using the System Status Application (SSA).
<b>Read all configuration</b>	The System Status application includes tools to take a snapshot of the system for use by Avaya for diagnostics. That snapshot can include a full copy of the system's configuration settings. This setting must be enabled for the SSA user to include a copy of the configuration in the snapshot.
<b>System Control</b>	If enabled, the SSA user is able to use SSA to initiate system shutdowns and memory card shutdown/restarts.
<b>SysMonitor Access</b>	If enabled, members of the Rights Group can use the System Monitor application to perform detailed diagnosis of system problems.

### Related links

[Rights Groups](#) on page 156

---

## Telephony APIs

Field	Description
<b>Enhanced TSPI Access</b>	If selected, applications in this rights group are able to use the system's Enhanced TSPI interface. This interface is currently used by the one-X Portal application server for its connection to the system.
<b>DevLink3</b>	If selected, applications in this rights group are able to use the system's DevLink3 interface.  This is a TCP based interface that streams real time call events (Delta3 records) and is the recommended replacement to the existing DevLink windows based DLL. A new Rights Group with a user name and password is required for external applications to connect via the DevLink3 interface.
<b>Location API</b>	If selected, applications in this rights group are able to use the system's Location API interface.

### Related links

[Rights Groups](#) on page 156

---

## HTTP

This tab sets the HTTP services supported for members of the group.

Field	Description
<b>DECT R4 Provisioning</b>	This service is used to allow the system to configure the DECT R4 master base station and to respond to handsets subscribing to the DECT R4 system. It requires both the system and DECT R4 master base station to be configured to enable provisioning. For full details refer to the DECT R4 Installation Manual.
Directory Read	If selected, members of the Rights groups have HTTP service read access to directory records.
Directory Write	If selected, members of the Rights groups have HTTP service read and write access to directory records.

### Related links

[Rights Groups](#) on page 156

---

## Web Services

These settings are used by users in rights groups using web services to configure and manage the system. These are currently not used on Standard Mode systems

### IP Office Service Rights

Field	Description
<b>Security Read All</b>	If selected, the rights group members can view system security settings.
<b>Security Write All</b>	If selected, the rights group members can change system security settings.
<b>Security Write Own Password</b>	If selected, members of the Rights Group can change their own password when requested to do so by the system. That request may be the result of a Password Change Period, Force new password or Account Expiry. The new password change is requested automatically at login time.
<b>Config Read All</b>	If selected, the rights group members can view system configuration settings
<b>Config Write All</b>	If selected, the rights group members can change system configuration settings.
<b>Backup</b>	If selected, the rights group members can initiate the system backup process.
<b>Restore</b>	If selected, the rights group members can initiate the system restore process.
<b>Upgrade</b>	If selected, the rights group members can initiate the system upgrade process.

### Web Manager Rights

Field	Description
<b>File Manager</b>	If selected, the rights group members are assigned Read only access to embedded file management configuration settings in Web Manager by default.
<b>Service Commands</b>	If selected, the rights group members are assigned Read only access to Service Commands configuration settings in Web Manager by default.
<b>Users, Extensions</b>	If selected, the rights group members are assigned Read only access to Users and Extension configuration settings in Web Manager by default.
<b>Groups, Auto Attendant (For Standard Edition only)</b>	If selected, the rights group members are assigned Read only access to Groups, Auto Attendant configuration settings in Web Manager by default.
<b>Incoming Call Routes, Alternate Route Selection, Short Codes</b>	If selected, the rights group members are assigned Read only access to Incoming Call Routes, Alternate Route Selection, and Short Codes configuration settings in Web Manager by default.
<b>System, Locations, time Profiles and Licensing</b>	If selected, the rights group members are assigned Read only access to on System, Locations, Time Profiles, and Licensing configuration settings in Web Manager by default.
<b>Lines</b>	If selected, the rights group members are assigned Read only access to Lines configuration settings in Web Manager by default.
<b>'Directory, Authorization codes, Account Codes</b>	If selected, the rights group members are assigned Read only access to Directory, Authorization Codes, and Account Codes configuration settings in Web Manager by default.

*Table continues...*



Field	Description
<b>IP Routes, WAN Ports, Firewall Profiles, RAS, Services, Tunnel (Applicable for IP500)</b>	If selected, the rights group members are assigned Read only access to IP Routes, WAN Portas, Firewall Profiles, RAS Services Users and Extension configuration settings in Web Manager by default.
<b>User Rights</b>	If selected, the rights group members are assigned Read only access to Users configuration settings in Web Manager by default.

### Related links

[Rights Groups](#) on page 156

## External

These settings are used by users in rights groups for external components using web services to configure and manage the system.

### IP Office Service Rights

Field	Description
<b>Voicemail Pro Basic</b>	If selected, the rights group members can read the configuration and perform backup, restore, and upgrade.
<b>Voicemail Pro Standard</b>	If selected, the rights group members can update the configuration and perform backup, restore, and upgrade.
<b>Voicemail Pro Administrator</b>	If selected, the rights group members can update the configuration and security settings.
<b>one-X Portal Administrator</b>	If selected, the rights group members can update the configuration and security settings. Does not include backup and restore.
<b>one-X Portal Super User</b>	If selected, the rights group members can perform backup and restore.
<b>Web Control Administrator</b>	If selected, the rights group members can update the configuration settings.
<b>Web Control Security</b>	If selected, the rights group members can update the security settings.
<b>WebRTC Gateway Administrator</b>	If selected, the rights group members can update the configuration settings.
<b>Media Manager Administrator</b>	If selected, the rights group members can update Media Manager configurations and settings. The rights group members can also access all archived recordings.
<b>Media Manager Standard</b>	If selected, the rights group members can have read-only access to Media Manager configurations and access to the recordings.

*Table continues...*

Field	Description
<b>Reporter Administrator</b>	If selected, the rights group members can have configuration access to Integrated Contact Reporter.  * <b>Note:</b> Integrated Contact Reporter is not supported in IP Office Release 11.0.
<b>Web Manager Rights</b>	These rights are used with web service access to systems such as IP Office Web Manager.

**Related links**

[Rights Groups](#) on page 156

---

## Service Users

These settings are displayed when **Service Users** is selected in the navigation pane and a particular service user is selected in the group pane.

The maximum number of service users is 64.

Field	Description
<b>Name</b>	Range = Up to 31 characters. Sets the service user's name.  The minimum name length is controlled through <b>General settings</b> .  * <b>Note:</b> If changing the user name and/or password of the current service user used to load the security settings, after saving the changes Manager should be closed. Not closing Manager will cause error warnings when attempting to send any further changes.
<b>Password</b>	Range = 9 to 31 characters. Sets the service user's password.  To change the current password click <b>Change</b> . Enter and confirm the new password. Note that an error will be indicated if the password being entered does not meet the password rules set through General settings.  To clear the cache of previous password details used by the password rules setting, click <b>Clear Cache</b> . For example, if the rule restricting the reuse of old passwords has been enabled, clearing the cache allows a previous password to be used again.

*Table continues...*

Field	Description
<b>Set New Password</b>	<p>Click the button to change your existing password. The button to set a new password appears only for a logged in Service User when the Service User tries to change it's own password. If the button is clicked, the IP Office system asks the Service User to type in the following details:</p> <ul style="list-style-type: none"> <li>• <b>Password:</b> New password for the logged in Service User.</li> <li>• <b>Confirm Password:</b> New password for the logged in Service User.</li> <li>• <b>Old Password:</b> The old password is used to re-authenticate the Service User for changing the password.</li> </ul>
<b>Account Expiry</b>	<p>Default = &lt;None&gt; (No Expiry). Not applicable to Web Manager.</p> <p>This option can be used to set a calendar date after which the account will become locked. The actual expiry time is 23:59:59 on the selected day. To prompt the user a number of days before the expiry date, set an <b>Expiry Reminder Time</b> on the security General Settings tab.</p>
<b>Rights Group Membership</b>	<p>The check boxes are used to set the <b>Rights Groups</b> to which the user belongs. The user's rights will be a combination of the rights assigned to the groups to which they belong.</p>

**Related links**

[Security Mode Field Descriptions](#) on page 138

# Part 3: System Configuration

# Chapter 10: Editing Configuration Settings

## IP500 V2 Operation

Before editing the system's configuration settings, it is important to understand how those settings are stored and used by the system.

The control unit holds copies of its configuration in both its internal non-volatile and RAM memory. A copy is also held on the System SD card (IP500 V2).

The copies in non-volatile memory and System SD card, are retained even if power to the control unit is removed. During power up, the system loads the configuration file stored on the System SD card into its RAM memory. Other systems load the configuration stored in non-volatile memory into RAM memory. The copy in RAM memory is then used to control the system's operation.

If the system encounters a problem using the configuration file in its System SD card's `/primary` folder, it attempt to use the copy in its non-volatile memory. For fully details of the IP500 V2 boot process and SD card usage refer to the IP Office Installation Manual.

Users actions such as changing their forward destinations or mailbox passcode are written to the configuration in RAM memory.

Changes made using Manager are written to the configuration in non-volatile memory and then copied into the RAM memory and System SD.

Between 00:00 and 00:30, a daily backup occurs which copies the configuration in the system's operation RAM memory back into its non-volatile memory and, on IP500 V2 system's, the System SD card. On IP500 V2 system, the contents of the system memory cards `/primary` folder can then also be automatically copied to the `/backup` folder by enabling **System | System | Automatic Backup**.

When the system is shutdown using the correct shutdown method, the configuration in RAM memory is copied to the non-volatile memory and System SD card.

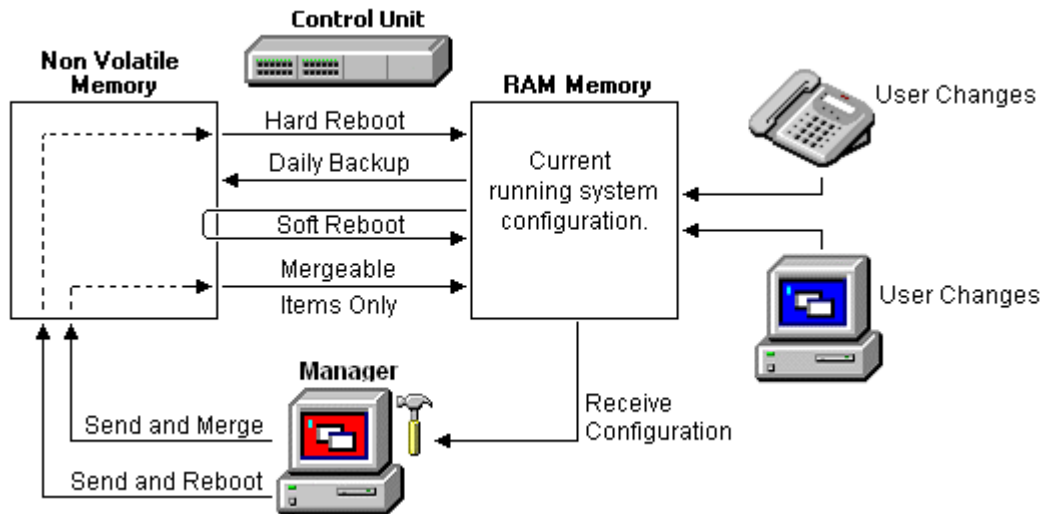

## Using Manager

When using Manager to edit the configuration settings, the following need to be remembered:

- Manager receives the current configuration settings from RAM memory. Therefore the configuration it receives includes any changes made by users up to that time. However it will not contain any subsequent changes made by users.
- When sending the configuration settings back to the system, Manager allows two choices, reboot or merge.
- Reboot sends the configuration to the system's non-volatile memory along with an instruction to reboot. Following the reboot, the new configuration in non-volatile memory is copied to the RAM memory and used.
- Merge sends the configuration to the system's non-volatile memory without rebooting. The system then copies those changes that are mergeable into the RAM memory. A key point here is that not all configuration settings are mergeable.

As a result of the above, it is important to bear the follow scenarios in mind:

- Changes made by users after a configuration is received by Manager may be lost when the configuration is sent back from Manager. Therefore it is preferable to always edit a recently received copy of the configuration rather than one that has been open for a period of time.
- If a merge is attempted with non-mergeable changes, those items will be written to the non-volatile memory but will not be copied to RAM memory. If a daily backup occurs, they will then be overwritten by the RAM. If a power loss reboot occurs, they will be written to RAM memory.

## Related links

- [Mergeable Settings](#) on page 167
- [Configuration Size](#) on page 177
- [Setting the Discovery Addresses](#) on page 178
- [Known System Discovery](#) on page 180
- [Opening a Configuration from a System](#) on page 182
- [Opening a Configuration Stored on PC](#) on page 184

- [Creating New Records](#) on page 185  
[Creating an Offline Configuration](#) on page 186  
[Importing and Exporting Settings](#) on page 188  
[Copying and Pasting](#) on page 191  
[Saving a Configuration onto PC](#) on page 191  
[Sending a Configuration](#) on page 192  
[Erasing the Configuration](#) on page 194  
[Default Settings](#) on page 194

## Mergeable Settings

The table below shows the configuration records for which changes can be merged and those that require a system reboot. The **Send Configuration** menu shown when sending a configuration to the system automatically indicates when the configuration is mergeable.

Configuration Setting	Mergeable	Notes
System   System	Yes	These settings are mergeable with the exception of <b>Locale</b> and <b>Favor RIP Routes over Static Routes</b> . Changing these settings requires a reboot of the system.
System   LAN   LAN Settings	No	
System   LAN   VoIP	No	<p>The following settings are mergeable:</p> <ul style="list-style-type: none"> <li>• <b>Auto-create Extn</b></li> <li>• <b>Auto-create User</b></li> <li>• <b>H.323 Signalling over TLS</b></li> <li>• <b>Remote Call Signalling Port</b></li> <li>• <b>Enable RTCP Monitoring on Port 5005</b></li> <li>• <b>RTCP collector IP address for phones</b></li> <li>• <b>Scope</b></li> <li>• <b>Initial keepalives</b></li> <li>• <b>Periodic timeout</b></li> <li>• <b>VLAN</b></li> <li>• <b>1100 Voice VLAN Site Specific Option Number (SSON)</b></li> <li>• <b>1100 Voice VLAN IDs</b></li> </ul> <p>The remaining settings are not mergeable. Changes to these settings will require a reboot of the system.</p>

*Table continues...*

Configuration Setting	Mergeable	Notes
System   LAN   Network Topology	No	
System   LAN   DHCP Pools	Yes	<p>These settings are mergeable. However, the following actions require a merge with service disruption.</p> <ul style="list-style-type: none"> <li>• Changing the <b>Start Address</b>, <b>Subnet Mask</b> or <b>Default Router</b> value for an existing DHCP Pool of addresses.</li> <li>• Decreasing <b>Pool Size</b> for an existing DHCP Pool of addresses.</li> <li>• Deleting an existing DHCP Pool of addresses.</li> </ul> <p>When these actions are performed, the DHCP (Server or DialIn) is re-initialized which triggers a reboot of the Avaya DHCP Clients (H.323 and SIP) in order to force the Avaya DHCP clients to renew their IP address lease and apply the new settings. For the remaining Avaya and non-Avaya DHCP clients, you must manually reboot the devices in order to force the IP Addresses lease renewal. Otherwise, the devices continue to use the allocated IP addresses until the IP addresses lease time out expires. IP address lease time out is set to three days.</p> <p>Note that IP Office supports phone reboot only for E129 and B179 SIP phone models.</p>
System   DNS	No	
System   Voicemail	Yes	These settings are mergeable with the exception of <b>Voicemail Type</b> and <b>Voicemail IP Address</b> . Changes to these settings requires a reboot of the system.
System   Telephony   Telephony	Yes	Changes to <b>Companding LAW</b> and <b>Media Connection Preservation</b> require a reboot.
System   Telephony   Park and Page	Yes	
System   Telephony   Tones and Music	Yes	<ul style="list-style-type: none"> <li>• Changes to <b>Disconnect Tone</b> requires a reboot.</li> <li>• Changes to <b>Busy Tone Detection</b> requires a reboot.</li> <li>• Deleting any of the hold music <b>Alternate Sources</b> requires a reboot.</li> </ul>
System   Telephony   Ring Tones	Yes	
System   Telephony   SM	Yes	
System   Telephony   Call Log	Yes	
System   Telephony   TUI	Yes	

*Table continues...*



Configuration Setting	Mergeable	Notes
System   Directory Services   LDAP	Yes	
System   Directory Services   HTTP	Yes	
System   System Events   Configuration	No	
System   System Events   Alarms	No	
System   SMTP	No	
System   SMDR	Yes	
System   VCM	Yes	
System   CCR	Yes	
System   Codecs	Yes	
System   VoIP	No	
System   VoIP Security	Yes	
System   Dialer	Yes	Changes to the <b>Operation</b> field or to the <b>Trunk Range / IP Office</b> table require a reboot.  It is recommended that you do not change the mergeable settings while the system is in use.
System   Contact Center	Yes	
Line   Analog Line   Line Settings	Yes	These settings are mergeable with the exception of the <b>Network Type</b> setting. Changes to this setting will require a reboot of the system.
Line   Analog Line   Analog Options	No	The <b>Allow Analog Trunk to Trunk Connect</b> setting is mergeable. The remaining settings are not mergeable. Changes to these settings will require a reboot of the system.

*Table continues...*

Configuration Setting	Mergeable	Notes
Line   BRI Line	No	<p>The following settings are not mergeable. Changes to these settings will require a reboot of the system.</p> <ul style="list-style-type: none"> <li>• <b>Line Sub Type</b></li> <li>• <b>Network Type</b></li> <li>• <b>TEI</b></li> <li>• <b>Add 'Not-end-to-end ISDN' Information Element</b></li> <li>• <b>Progress Replacement</b></li> <li>• <b>Clock Quality</b></li> <li>• <b>Force Number Plan to ISDN</b></li> </ul> <p>Decreasing the <b>Number of Channels</b> setting requires a a “merge with service disruption”. When the configuration file is sent to the system, active calls on the deleted channels are cleared.</p> <p>The remaining settings are mergeable.</p>
Line   BRI Line   Channels	Yes	
Line   E1 PRI Line	No	<p>The following settings are not mergeable. Changes to these settings require a system reboot.</p> <ul style="list-style-type: none"> <li>• <b>Line Sub Type</b></li> <li>• <b>Network Type</b></li> <li>• <b>TEI</b></li> <li>• <b>Channel Allocation</b></li> <li>• <b>CRC Checking</b></li> <li>• <b>Clock Quality</b></li> <li>• <b>Add 'Not-end-to-end ISDN' Information Element</b></li> <li>• <b>Progress Replacement</b></li> <li>• <b>Force Number Plan to ISDN</b></li> <li>• <b>Line Signalling</b></li> </ul> <p>Decreasing the <b>Number of Channels</b> setting requires a a “merge with service disruption”. When the configuration file is sent to the system, active calls on the deleted channels are cleared.</p> <p>The remaining settings are mergeable.</p>
Line   E1 Short Codes	Yes	

*Table continues...*

Configuration Setting	Mergeable	Notes
Line   E1 PRI Channels	No	<p>The following settings are mergeable:</p> <ul style="list-style-type: none"> <li>• <b>Line Appearance ID</b> (ETSI, ETSI CHI)</li> <li>• <b>Admin</b> (ETSI CHI)</li> <li>• <b>Incoming Group ID</b> (ETSI CHI)</li> <li>• <b>Outgoing Group ID</b> (ETSI CHI)</li> </ul> <p>The remaining settings are not mergeable. Changes to these settings require a system reboot.</p>
Line   E1-R2 Options	No	<p>Changing the <b>Admin</b> setting is mergeable.</p> <p>The remaining settings are not mergeable. Changes to these settings will require a reboot of the system.</p>
Line   E1-R2 Channels	No	<p>The following settings are mergeable:</p> <ul style="list-style-type: none"> <li>• <b>Incoming Group ID</b></li> <li>• <b>Outgoing Group ID</b></li> <li>• <b>Admin</b></li> </ul> <p>The remaining settings are not mergeable. Changes to these settings require a system reboot.</p>
Line   E1-R2 MFC Group	No	
Line   E1-R2 Advanced	No	
Line   US T1 Line	No	<p>The following settings are mergeable:</p> <ul style="list-style-type: none"> <li>• <b>Admin</b></li> <li>• <b>Prefix</b></li> </ul> <p>The remaining settings are not mergeable. Changes to these settings require a system reboot.</p>
Line   T1 Channels	No	<p>The following settings are mergeable:</p> <ul style="list-style-type: none"> <li>• <b>Incoming Group ID</b></li> <li>• <b>Outgoing Group ID</b></li> <li>• <b>Line Appearance ID</b></li> <li>• <b>Admin</b></li> </ul> <p>The remaining settings are not mergeable. Changes to these settings require a system reboot.</p>

*Table continues...*

Configuration Setting	Mergeable	Notes
Line   T1 ISDN Line	No	<p>The following settings are mergeable:</p> <ul style="list-style-type: none"> <li>• <b>Prefix</b></li> <li>• <b>Send Redirecting Number</b></li> <li>• <b>Admin</b></li> <li>• <b>Send original calling party for forwarded and twinning calls</b></li> <li>• <b>Originator number for forwarded and twinning calls</b></li> </ul> <p>The remaining settings are not mergeable. Changes to these settings require a system reboot.</p>
Line   T1 ISDN Channels	No	<p>The following settings are mergeable:</p> <ul style="list-style-type: none"> <li>• <b>Incoming Group ID</b></li> <li>• <b>Outgoing Group ID</b></li> <li>• <b>Line Appearance ID</b></li> <li>• <b>Admin</b></li> </ul> <p>The remaining settings are not mergeable. Changes to these settings require a system reboot.</p>
Line   T1 ISDN TNS	No	
Line   T1 ISDN Special	No	
Line   T1 ISDN Call by Call	No	
Line   H.323 Line   VoIP Line	Yes	
Line   H.323 Line   Short Codes	No	For line subtypes ETSI, ETSI CHI, QSIG A, and QSIG B, these settings are mergeable. Changes to these settings do not require a reboot of the system.
Line   H.323 Line   VoIP Settings	Yes	
Line   IP DECT Line   Line	Yes	When creating an IP DECT line, these settings are mergeable. You can also remove an IP DECT line without rebooting. Changing an IP DECT line that has been imported into the configuration is not mergeable.
Line   IP DECT Line   Gateway	Yes	
Line   IP DECT Line   VoIP	Yes	
Line   SIP Line   SIP Line	Yes	<p>These settings are mergeable with the exception of the <b>Line Number</b> setting. Changing the <b>Line Number</b> setting requires a “merge with service disruption”. When the configuration file is sent to the system, the SIP trunk is restarted and all calls on the line are dropped.</p> <p>Deleting a SIP line requires a “merge with service disruption”.</p>

*Table continues...*

Configuration Setting	Mergeable	Notes
Line   SIP Line   Transport	Yes	Changing these settings requires a “merge with service disruption”. When the configuration file is sent to the system, the SIP trunk is restarted.  Note that <b>ITSP Proxy Address</b> and <b>Calls Route via Registrar</b> are mergeable.  Deleting a SIP line requires a “merge with service disruption”.
Line   SIP Line   SIP URI	Yes	These settings are mergeable, with the following exceptions.  • <b>Registration</b>  • <b>Identity Header</b>  These settings require a “merge with service disruption”. When the configuration file is sent to the system, the SIP trunk is restarted and all calls on the line are dropped.
Line   SIP Line   VoIP	Yes	
Line   SIP Line   T38 Fax	Yes	
Line   SIP Line   SIP Credentials	Yes	
Line   SIP Line   SIP Advanced	Yes	These settings are mergeable, with the exception of the <b>Media Connection Preservation</b> setting. Changing the <b>Media Connection Preservation</b> setting requires a “merge with service disruption”. When the configuration file is sent to the system, the SIP trunk is restarted and all calls on the line are dropped.
Line   SIP Line   Engineering	Yes	
Line   SIP DECT Line   SIP DECT Base	No	
Line   SIP DECT Line   VoIP	No	
Line   SM Line   Session Manager	Yes	Changing the <b>In Service</b> setting to <b>Disabled</b> (out of service) requires a system reboot. However, changing the <b>In Service</b> setting to <b>Enabled</b> is mergeable. Configuration changes made while the line is out of service are also mergeable.
Line   SM Line   VoIP	Yes	
Line   SM Line   T38 Fax	Yes	
Line   IP Office Line   Line	No	
Line   IP Office Line   Short Codes	No	For line subtypes ETSI, ETSI CHI, QSIG A, and QSIG B, these settings are mergeable. Changes to these settings do not require a reboot of the system.

*Table continues...*

Configuration Setting	Mergeable	Notes
Line   IP Office Line   VoIP Settings	Yes	For line subtypes ETSI, ETSI CHI, QSIG A, and QSIG B, these settings are mergeable. Changes to these settings do not require a reboot of the system.
Line   IP Office Line   T38 Fax	Yes	
Control Unit   Unit	No	
Extension   Extn	Yes	Mergeable except <b>Base Extension</b> , <b>Extension ID</b> , and <b>Caller Display Type</b> .
Extension   Analog Extension   Analog	No	
Extension   H323 Extension   VoIP	No	
Extension   SIP Extension   VoIP	No	
Extension   SIP Extension   T38 Fax	Yes	
Extension   IP DECT Extension	Yes	These settings are mergeable with the exception of the <b>Reserve License</b> setting. Changing the <b>Reserve License</b> settings requires a reboot of the system.
Extension   SIP DECT Base	No	
User   User	Yes	
User   Voicemail	Yes	
User   DND	Yes	
User   Short Codes	Yes	
User   Source Numbers	Yes	
User   Telephony   Call Settings	Yes	
User   Telephony   Supervisor Settings	Yes	
User   Telephony   Multi-line Options	Yes	
User   Telephony   Call Log	Yes	
User   Telephony   TUI	Yes	
User   Forwarding	Yes	
User   Dial In	Yes	
User   Voice Recording	Yes	
User   Button Programming	Yes	
User   Menu Programming   Hunt Group	Yes	

*Table continues...*

Configuration Setting	Mergeable	Notes
User   Menu Programming   4400/6400	Yes	
User   Mobility	Yes	
User   Group Membership	Yes	
User   Announcements	Yes	
User   SIP	Yes	
User   Personal Directory	Yes	
User   Web Self Administration	Yes	
Group   Group	Yes	
Group   Queuing	Yes	
Group   Overflow	Yes	
Group   Fallback	Yes	
Group   Voicemail	Yes	
Group   Voice Recording	Yes	
Group   Announcements	Yes	
Group   SIP	Yes	
Short Code   Short Code	Yes	
Service   Service	Yes	
Service   Bandwidth	Yes	
Service   IP	Yes	
Service   Autoconnect	Yes	
Service   Quota	Yes	
Service   PPP	Yes	
Service   Fallback	Yes	
Service   Dial In	Yes	
SSL VPN Service   Service	Yes	
SSL VPN Service   Session	Yes	
SSL VPN Service   NAPT	Yes	
SSL VPN Service   Fallback	Yes	
RAS   RAS	Yes	
RAS   PPP	Yes	
Incoming Call Route   Standard	Yes	
Incoming Call Route   Voice Recording	Yes	

*Table continues...*

Configuration Setting	Mergeable	Notes
Incoming Call Route   Destinations	Yes	
WAN Port   WAN Port	No	
WAN Port   Frame Relay	No	
WAN Port   DLCIs	No	
WAN Port   Advanced	No	
Directory   Directory Entry	Yes	
Time Profile   Time Profile	Yes	
Firewall Profile   Standard	Yes	
Firewall Profile   Custom	Yes	
Firewall Profile   Static NAT	Yes	
IP Route   IP Route	Yes	
IP Route   RIP Dynamic Routing	Yes	
Account Code   Account Code	Yes	
Account Code   Voice Recording	Yes	
License   License	Yes	
License   Remote Server	No	The <b>Reserved Licenses</b> setting is mergeable. The remaining settings are not mergeable. Changes to these settings requires a reboot of the system.
Tunnel   Tunnel (L2TP)	No	
Tunnel   Main (IPSec)	No	
Tunnel   IKE Policies (IPSec)	No	
Tunnel   IKE Policies (IPSec)	No	
Auto Attendant   Auto Attendant	Yes	
Auto Attendant   Actions	Yes	
Authorization Codes	Yes	
User Rights   User	Yes	
User Rights   Short Codes	Yes	
User Rights   Button Programming	Yes	
User Rights   Telephony   Call Settings	Yes	
User Rights   Telephony   Supervisor Settings	Yes	

*Table continues...*



Configuration Setting	Mergeable	Notes
User Rights   Telephony   Multi-line Options	Yes	
User Rights   Telephony   Call Log	Yes	
User Rights   User Rights Membership	Yes	
User Rights   Voicemail	Yes	
User Rights   Forwarding	Yes	
ARS   ARS	Yes	
RAS Location Request	Yes	
Location	Yes	

### Related links

[Editing Configuration Settings](#) on page 165

---

## Configuration Size

The maximum size of the configuration file that can be loaded into an IP500 V2 control unit is 2.0 MB.

When you attempt to save a configuration that is too large, you will be prompted and the save is canceled.

During normal operation, additional configuration records can be added to the configuration without using Manager (for example call log records and directory records made from phones). If, during the overnight backup to flash memory, the configuration is found to be too large, records will be removed until the configuration is sufficiently small to be backed up. The records removed are call log records, system directory records and then personal directory in that order. Note that those records will still exist in the configuration running the system in its RAM memory, however if the system is restarted they will disappear as the configuration is reloaded from the Flash memory.

Figures for all individual records in the configuration cannot be given as they vary. The list below gives typical values, in bytes, for common records:

Physical Extension: 70.

IP Extension: 70.

User: 170.

User Short Code: 40.

DSS Button: 20.

Hunt Group: 100.

Hunt Group member: 10.

System Short Code: 10.

Normal Service: 220.

Intranet Service: 240.

WAN Service: 400.

RAS Service: 110.

Incoming Call Route: 30.

WAN Port (PPP): 70.

WAN Port (FR): 120.

Directory Record: 70.

Time Profile: 40.

Time Profile Record: 20.

Firewall Profile: 40.

Custom Firewall Record: 80.

IP Route (Static): 30.

License Key: 40.

Account Code: 40.

Logical LAN: 60.

Tunnel (L2TP): 200.

Tunnel (IPSec): 110.

### Related links

[Editing Configuration Settings](#) on page 165

---

## Setting the Discovery Addresses

By default, when  or **File | Open configuration** is selected, Manager's **Select IP Office** window opens. It performs a UDP broadcast to the address 255.255.255.255. This broadcast will only locate systems that are on the same network subnet as the PC running Manager.

For systems not located on the same subnet as the Manager PC, the following options are supported.

**Specific Addressing** The **Unit/Broadcast Address** shown on the **Select IP Office** menu can be changed to the specific IP address of the required system. A single address is routable and so can be used to discover a system on another subnet.

**TCP Discovery Address Ranges** A set of TCP addresses and address ranges can be specified for use by the **Select IP Office** discovery process.

**Known System Discovery** Manager can write the details of systems it discovers to a file. The list of systems in that file can then be used for access to those systems.

**DNS Lookup** Manager can be configured to locate systems using DNS name lookup. This requires the systems on a customer network to be added as names on the customer's DNS server and the Manager PC to be configured to use that server for DNS name resolution. The use of DNS is configured through **File | Preferences | Discovery**.

**Changing the Initial Discovery Settings** The **Discovery** tab of the **Preferences** menu can be used to set the UDP and TCP addresses used by the discovery process run by the **Select IP Office** menu.

1. Select **File | Preferences** menu.
2. Select the **Discovery** tab.

**TCP Discovery:** Default = On. This setting controls whether Manager uses TCP to discover systems. The addresses used for TCP discovery are set through the IP Search Criteria field below.

**NIC IP/NIC Subnet** This area is for information only. It shows the IP address settings of the LAN network interface cards (NIC) in the PC running Manager. Double-click on a particular NIC to add the address range it is part of to the IP Search Criteria. Note that if the address of any of the Manager PC's NIC cards is changed, the Manager application should be closed and restarted.

**IP Search Criteria** This section is used to enter TCP addresses to be used for the TCP discovery process. Individual addresses can be entered separated by semi-colons, for example 135.164.180.170; 135.164.180.175. Address ranges can be specified using dashes, for example 135.64.180.170 - 135.64.180.175.

**UDP Discovery:** Default = On This settings controls whether Manager uses UDP to discover systems.

**Enter Broadcast IP Address:** Default = 255.255.255.255 The broadcast IP address range that Manager should use during UDP discovery. Since UDP broadcast is not routable, it will not locate systems that are on different subnets from the Manager PC unless a specific address is entered.

**Use DNS:** Selecting this option allows Manager to use DNS name (or IP address) lookup to locate a system. Note that this overrides the use of the TCP Discovery and UDP Discovery options above. This option requires the system IP address to be assigned as a name on the users DNS server. When selected, the **Unit/Discovery Address** field on the Select IP Office dialogue is replaced by a **Enter Unit DNS Name or IP Address** field.

**SCN Discovery:** If enabled, when discovering systems, the list of discovered systems will group systems in the same Small Community Network and allow them to be loaded as a single configuration. At least one of the systems in the Small Community Network must be running Release 6.0 or higher software. See [Configuring Small Community Networking](#) on page 786. This does not override the need for each system in the Small Community Network to also be reachable by the **TCP Discovery** and or **UDP Discovery** settings above and accessible by the router settings at the Manager location.

**Related links**

[Editing Configuration Settings](#) on page 165

---

## Known System Discovery

The **Select IP Office** menu normally displays systems discovered by Manager using either UDP broadcast and or TCP requests. Manager can be configured to also record details of discovered units and then display a list of those previously discovered ('known') systems.

**Related links**

[Editing Configuration Settings](#) on page 165

---

## Configuring Manager for Known System Discovery

**About this task**

Use of known systems discovery is not enabled by default. The Manager must be configured for the feature with a file location to which it can store and retrieve known system details.

**Procedure**

1. Select **File | Change Working Directory**.

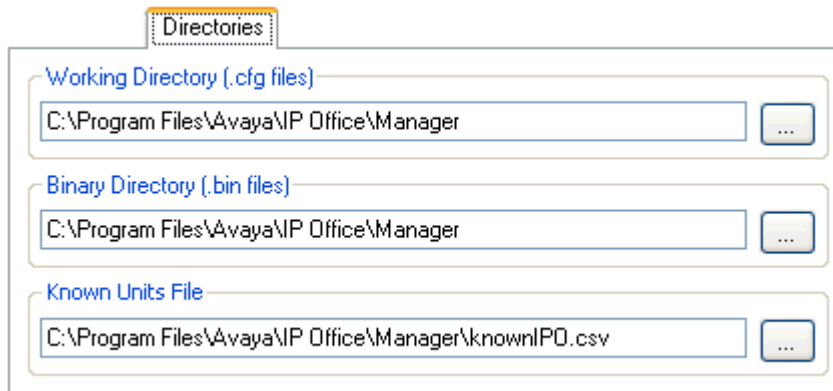

2. In the **Known Units File** field, enter the directory path and file name for a CSV file into which Manager can write details of the systems it discovers.  
If the file specified does not exist it will be created by Manager.
3. Click **OK**.

---

## Using Known System Discovery

**About this task**

## Procedure

1. When the Select IP Office screen is displayed click on **Known Units**.

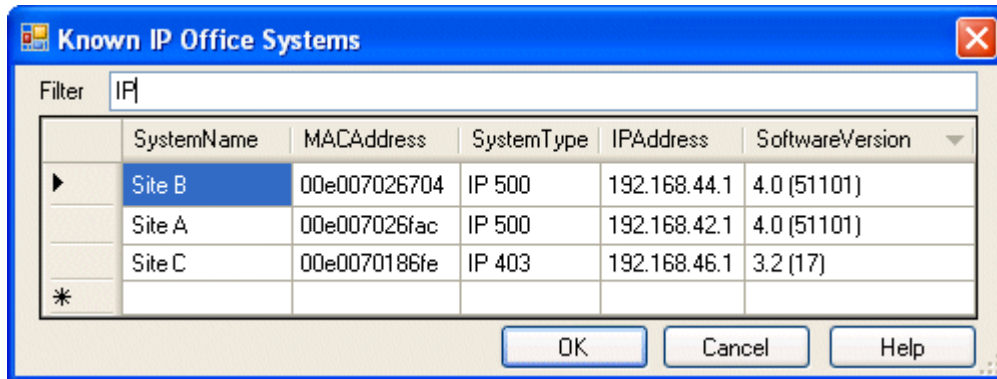

2. The screen displays the list of systems previously discovered and stored in the CSV file.
3. To select an control unit, highlight the row containing unit data and click **OK**.  
The selected unit will appear in the Select IP Office window.
4. To filter displayed units, type the first few characters of the unit name in the **Filter** field.  
Any unit whose name does not match the filter will be temporarily hidden.
5. Each discovery appends data to the known unit list.

It is possible that details of some records in the list may be out of date. Right clicking on the leftmost (grey) column of any row will bring up a floating menu offering the options of **Refresh** and **Delete**.

6. A new record may be manually added without having to access the system first through normal discovery.

Enter the IP address of the new system in the IP Address column of the blank row shown with a \* and select **Refresh** from the floating menu. This will update the Known Units file with data relating to the unit with the specified address.

7. Select **Cancel** to return to the **Select IP Office** menu.

## Result

### \* Note:

- The key used by the Known Systems CSV file is the IP address. The file cannot contain records for separate systems that use the same IP address for access.
- The file can be made read only. In that case any attempts using Manager to update the file will be ignored.

---

## Opening a Configuration from a System

The initial IP address ranges in which Manager searches for systems are set through the Manager preferences (File | Preferences | Discovery). By default it scans the local network of the Manager PC.

Start Manager. If Manager is already started and a configuration is open in it, that configuration must be closed first.

- If Manager is set to Auto Connect on start up, it will scan for systems automatically and either display the list of systems discovered or automatically start login to the only system discovered.
- Otherwise, click on  or select **File | Open Configuration**.

The Select IP Office window appears, listing those systems that responded.

- If Server Edition systems are detected, they are grouped together. By default the configuration of those systems cannot be opened using Manager in **Advanced View** mode and the configuration of a Primary Server can only be opened if the Open with Server Edition Manager option is also selected.
- If Manager has been set with SCN Discovery enabled, systems in a Small Community Network are grouped together. The checkbox next to the network name can be used to load the configurations of all the configurations into Small Community Network management mode.
- If the system required was not found, the **Unit/Broadcast Address** used for the search can be changed. Either enter an address or use the drop-down to select a previously used address. Then click **Refresh** to perform a new search.
- The address ranges used by Manager for searching can be configured through the **File | Preferences | Discovery** tab.
- A list of known systems can be stored and used.
- Manager can be configured to search using DNS names. See the setting File | Preferences | Discovery | Use DNS
- .
- Systems found but not supported by the version of Manager being used will be listed as **Not Supported**.
- If the system detected is running software other than from its primary folder, a  warning icon will be shown next to it. The configuration can still be opened but only as a read-only file.

When you have located the system required, check the box next to the system and click **OK**.

If the system selected is a Server Editions system and Manager is not running in Server Edition mode, an **Open with Server Edition Manager** checkbox is shown and pre-selected. Clicking **OK** will switch Manager to its Server Edition mode before loading the configuration.

The system name and password request is displayed. Enter the required details and click **OK**.

The name and password used must match a service user account configured within the system's security settings.

Additional messages will inform you about the success or failure of opening the configuration from the system.

The method of connection, secure or insecure, attempted by Manager is set the applications Secure Communications preferences setting.

- When **Secure Communications** is set to **On**, a  padlock icon is displayed at all times in the lower right Manager status field.
- New installations of Manager default to having **Secure Communications** enabled. This means Manager by default attempts to use secure communications when opening a configuration.
- For Server Edition systems, Manager will always attempt to use secure communications regardless of the **Secure Communications** setting.
- If no response to the use of secure communication is received after 5 seconds, Manager will offer to fallback to using unsecured communications.

Following a successful log in, the configuration is opened in Manager. The menus and options displayed will depend on the type of system configuration loaded.

### Login Messages

While attempting to login to a system, various additional messages may be displayed.

#### Configuration Not Loaded Messages

**Access Denied** This is displayed as the cause if the service user name/password were incorrect, or the service user has insufficient rights to read the configuration. The Retry option can be used to log in again but multiple rejections in a 10 minute period may trigger events, such as locking the user account, set by the Password Reject Limit and Password Reject Action options in the systems security settings.

**Failed to communicate with system** This is displayed as the cause if the network link fails, or the secure communication mode is incorrect (for example Manager is set to unsecured, but the system is set to secure only).

**Account Locked** The account of the service user name and password being used is locked. This can be caused by a number of actions, for example too many incorrect password attempts, passing a fixed expiry date, etc. The account lock may be temporary (10 minutes) or permanent until manually unlocked. An account can be enabled again through the system's security settings.

### Additional Messages

**Your service user account will expire in X days** This message indicates that an Account Expiry date has been set on the system service user account and that date is approaching. Someone with access to the system's security settings will be required to set a new expiry date.

**Your password will expire in X days. Do you wish to change it now?** This message indicates that password ageing has been configured in the system's security settings. If your password

expires, someone with access to the system's security settings will be required to unlock the account.

**Change password** Through the system's security settings, a service user account can be required to change their password when logging in. The menu provides fields for entering the old password and new password.

**Contact Information Check - This configuration is under special control** This message will appear if a Manager user with administrator rights has entered their contact information into the configuration. For example to indicate that they do not want the configuration altered while a possible problem is being diagnosed. The options available are:

**Retain | Replace | Cancel** This message appears when it is detected that the configuration of one of the systems in a Server Edition network has previously been edited directly rather than via access to the primary system. Select **Replace** to replace the system's update configuration with the copy already held by the primary server. Select **Retain** to keep the already updated configuration.

**Cancel** Select this option to close the configuration without making any changes.

**Set configuration alteration flag** Select this option if the configuration is being opened because some urgent maintenance action. When the configuration is next opened, the fact that it has been altered will be indicated on the **System | System** tab.

**Delete Contact Information** Select this option to take the system out of special control.

**Leave contact information and flags unchanged (Administrators only)** This option is only available to service users logging in with administrator rights.

#### Related links

[Editing Configuration Settings](#) on page 165

---



## Opening a Configuration Stored on PC

### About this task

A configuration file previously saved on the PC can be reopened in Manager. This method of access does not require entry of a service user name and password. All parts of the configuration are visible.

Use either of the following processes to load a saved configuration file:

### Procedure

1. Click  the main toolbar or select **File | Offline | Open File** from the menu bar. If the files is one that has previously been opened offline, click the ▼ symbol next to  in the main toolbar
2. An Open configuration file window appears.

Use this to browse to the required configuration file.



3. Select the file and click **Open**.

**Related links**

[Editing Configuration Settings](#) on page 165

---

## Creating New Records

There are a number of ways in which you can add new records to the configuration currently loaded in Manager.

**Related links**

[Editing Configuration Settings](#) on page 165

---

## Adding a New Record Using the Details Pane

**About this task****Procedure**

1. Use the navigation pane, groups pane or navigation toolbar, select an existing record of the type required.
  2. Click  at the top-right of the details pane.
  3. Select the type of record required.  
For example, with extensions you can select from **H.323 Extension** or **SIP Extension**.
  4. Complete the settings for the new record and click **OK**.
- 

## Adding a New Record Using the Group Pane

**About this task****Procedure**

1. Using the navigation pane or navigation toolbar, select the type of record required.
  2. Right-click on the group pane and select  **New**.
  3. If a list is displayed, select the specific type of record required.
  4. Complete the settings for the new record and click **OK**.
- 

## Adding a New Record Using the Navigation Pane

**About this task**

## Procedure

1. In the navigation pane, right-click on the type of record required and select  **New**.
2. If a list is displayed, select the specific type of record required.
3. Complete the settings for the new record and click **OK**.

---

## Other record creation methods

### About this task

#### Procedure

1. Import records

New records can be created for users, hunt groups, short codes and directory entries by importing files. See [Importing and Exporting Settings](#) on page 188.

2. Automatically create records

There are scenarios where new records are automatically added to the configuration:

- Certain default records are added to the configuration when a new system is started or when a system configuration is erased.
- New records for extensions and lines are automatically added to match the hardware present when a system is started or rebooted.
- For telephones connected via IP links (H.323, SIP and DECT), the system can be configured to automatically create extension and or user records to match the telephone.

3. Use templates to create records

Manager supports a number of methods by which new records can be created from templates. See [Working with Templates](#) on page 600.

---

## Creating an Offline Configuration

### About this task

Manager can be used to create a new configuration without connecting to a system. This allows the creation of a configuration prior to installation of the real system and so can be used to speed up the installation process.

The configuration created must match the physical equipment in the system into which the configuration will be loaded. Doing otherwise may cause the system to reset and experience other problems.

The **Create Configuration** tool includes all control units, external expansion modules and trunk cards supported. It is your responsibility to confirm what equipment is supported in your locale.

## Creating a New Configuration

### Procedure

1. Close or save any configuration currently open.
2. Click  in the main toolbar or select **File | Offline | Create New Config**.
3. You should set the **Configuration, Locale, Extension Number Length** and **System Unit** first.

Changing any of these after you start selecting other system hardware will reset the hardware selections.

4. Select the type of **Configuration** you want to create.

The other options available will change depending on the selection. If the menu has been started from Manager running in Server Edition mode, the only option is **Server Edition Edition**.

5. Select the **Locale** for the system.

This defines a range of features such as default telephony settings.

6. The **Extension Number Length** setting value can be **None** or **3** to **15**.

If a value is selected, all default extension, user and hunt group extension numbers created by Manager will be that length. In addition Manager will display a warning if an extension number of a different length is entered when editing the configuration.

7. Select the type of **System Unit**.

Select the hardware components for the system. For a Server Edition system this is only necessary if a Expansion System (V2) is selected as the **System Units** option.

8. Select the additional cards to include in the control unit.

The number and type of cards selectable will depend on the control unit type.

9. Select the external expansion modules to also include in the system.

10. Click **OK**.

11. For non-Server Edition systems, the configuration is created and loaded into Manager.

For Server Edition systems, the Initial Configuration menu for the selected type of system unit is displayed. Complete the menu and click **Save**.

12. Once this configuration has been edited as required it can be saved on the PC or sent to a system.

13. **To Save a Configuration File on the PC Use File | Save Configuration.**

14. **To Send the Configuration to a System** If the system which you want to use the configuration is available, use File | Offline | Send Configuration to send the configuration to it.

 **Warning:**

This action will cause the system to reboot and will disconnect all current calls and service.

- Ensure that you have a copy of the systems existing configuration before overwriting it with the off-line configuration.
- After sending the configuration, you should receive the configuration back from the system and note any new validation errors shown by Manager. For example, if using Embedded Voicemail, some sets of prompt languages may need to be updated to match the new configurations locale setting using the Add/Display VM Locales option.

**Related links**

[Editing Configuration Settings](#) on page 165

---

## Importing and Exporting Settings

Manager can import configuration settings created elsewhere. This can be useful when setting up a new system or sharing common settings such as a directory between systems.

The system supports LDAP (**System | Directory Services | LDAP**) for automatic importation of directory records (LDAP Version 2).

The system also supports HTTP (**System | Directory Services | HTTP**) for automatic importation of directory records.

 **Note:**

You can also manage configuration settings using templates. See [Working with Templates](#) on page 600.

Settings are imported and exported in the following formats:

- **Binary Files (.exp)** These are non-editable files. During import and export it is possible to select what types of records should be included in the file. During import the whole file is imported.
- **Comma Separated Variable Text Files (.csv)** These are plain text files. In addition to being exported from a system these files can be created and edited using programs such as WordPad or Excel.

When opening a .csv file in Excel it will alter the way some data is displayed, automatically changing the display format of dates and long numbers such as phone numbers.

**UTF-8 Character Encoding** Manager imports and exports CSV files using UTF-8 character encoding which uses a multiple bytes to support characters with diacritic marks such as ä. Other applications, such as Excel, may, depending on the user PC settings, use different encoding which

will cause such characters to be removed or corrupted. Care should be taken to ensure that any tool used to create or edit the CSV supports all the characters expected and uses UTF-8 format.

- **Importing into Manager from Excel** From Excel save the file as a .csv. This file will use ANSI character encoding. Open the file in Notepad and use the **Save As** option to rename the file and select UTF-8 encoding. Import the UTF-8 version of the file into Manager.
- **Exporting from Manager into Excel** Do not double-click on the file exported from Manager. Start Excel and use **File | Open** to select the file. Excel will recognize that the file uses UTF-8 encoding and will start its text file importation wizard. Follow the wizard instructions and select comma as the field delimiter.

## CSV File Formats

The format is CSV using commas as field separator, no text delimiters and no header row. The simplest way to check the required format for a CSV file prior to import, is to export and a file from an existing system configuration.

File Name	Fields in Order
<b>Configuration</b>	Proprietary format. Note that this does not contain all configuration fields.
<b>License</b>	The License option is only available for export and only for ADI licenses present on the system.
<b>Short Code</b>	Code, Telephone Number, Feature.
<b>User</b>	Name, Extension, User Rights, Email Address, Full Name, Password, VoiceMail Code, Login Code, UserTemplate, ExtensionTemplate.
<b>Directory</b>	Name, Number, Speed Dial.
<b>Group</b>	Name, Extension, Group, Hunt, Rotary, Longest Waiting, Queuing On, Voicemail On, Broadcast, Voicemail Email.

### \* Note:

**Group:** Apart from Name, Extension and Voicemail Email, the fields use a 1 or 0 value for on or off.

The format of the system CSV is too complex to be described. It is a full export of all the system's configuration settings. This file format should only be used for export and import between systems and not for any offline editing.

## Using the CSV Configurator spreadsheet

You can use the CSV Configurator spreadsheet to create or modify multiple configuration entries. The CSV Configurator spreadsheet is available in the Manager application folder. By default, Manager is installed under C:\Program Files or C:\Program Files (x86).

The remaining path and file name is ... \Avaya\IP Office\Manager\IP Office User CSV Configurator.xlsm.

Follow the procedure below to export configuration settings. You can then use the exported files with the CSV Configurator spreadsheet. Follow the instructions in the spreadsheet.

## Related links

[Editing Configuration Settings](#) on page 165

## Exporting Settings

### About this task

#### Procedure

1. Select **File | Import/Export...** from the menu bar.
2. Select **Export**.
3. Select the type of file.

The list of exportable record types will change to match the file type.

4. Select the types of items that should be exported.
5. Use the **Save In** path to select the location for the exported files.

The default location used is a subfolder in the Manager application directory based on system name of the currently loaded system. For example, `...\Avaya\IP Office\Manager\System_1`.

6. Click **OK**.

---

## Importing Settings

Importing settings will overwrite any existing records that match a record being imported

#### Procedure

1. Select **File | Import/Export...** from the menu bar.
2. Select **Import**.
3. Select the type of file.

The list of items will change to match the type of file selected and whether a matching file or files is found in the current file path.

4. Use **Look In** to adjust the file path.

The default location used is a subfolder in the Manager application directory based on system name of the currently loaded system. For example, `...\Avaya\IP Office\Manager\System_1`.

5. Select the types of items that should be imported.
6. Click **OK**.

---

## Copying and Pasting

Manager supports the normal Windows methods of cutting, copying, pasting and deleting records and settings. These can be accessed through the **Edit** menu in the menu bar or using the standard Windows keyboard shortcuts for those actions. They can also be accessed by selecting a record or text field and then right-clicking.

Copy and paste can be used with the navigation and group panes to create a new record with the same settings as the original. The copy will be renamed as **Copy of ...** to avoid conflicting with the original.

When using copy and paste between individual settings fields, whether on the same record or a different record, care should be taken to ensure that the fields use the same type of data. Similarly copying a record in the navigation or group pane and then pasting it into the details pane will prompt Manager to paste the copied records data into the first field of the current record in the details pane. As a general rule, cut and paste actions should be used with the same pane and within similar record types.

For users and user rights, a number of controls have been provided to copy settings between a user and a user right or vice versa. See [Configuring User Rights](#) on page 664.

### Related links

[Editing Configuration Settings](#) on page 165

---

## Saving a Configuration onto PC

The system configuration settings shown within Manager can be saved as a .cfg file on the Manager PC. These files can be used as backups or sent to other persons to aid problem diagnostics. Note however that an offline configuration file does not include the Audit Trail records for the system.

### Automatically Saving Sent Configurations

By default, Manager creates a file copy of the configuration before it is sent to the system. This copy is stored in Manager's Working Directory using the system name and .cfg. This behavior is controlled by the Backup File on Send (File | Preferences | Security) option.

The number of backups of each systems configuration can be limited to a set number of the most recent copies.

### Saving a Configuration Received from a System

Select **File | Save Configuration as** from the menu bar.

### Saving a Configuration opened on the PC

Click  in the main toolbar or select **File | Save Configuration** from the menu bar.

## Related links

[Editing Configuration Settings](#) on page 165

---

# Sending a Configuration

The current configuration settings open within Manager can be sent to the system. The method depends on whether Manager is being used to edit the configuration of a single system or a network of systems.

## Sending an Individual System Configuration

The first steps of this process depend on whether you are sending a configuration received from the system or sending one opened offline/created new.

- **A Configuration Opened from a System** Click  in the main toolbar or select **File | Save Configuration** from the menu bar.
- **A Configuration Created Offline or Opened from a PC File** Select **File | Offline | Send Config** from the menu bar.

The **Send Configuration** menu is displayed.

**Configuration Reboot Mode** If Manager thinks the changes made to the configuration settings are mergeable, it will select **Merge** by default, otherwise it will select **Immediate**.

- **Merge** Send the configuration settings without rebooting the system. This mode should only be used with settings that are mergeable. Refer to Mergeable Settings.
- **Immediate** Send the configuration and then reboot the system.
- **When Free** Send the configuration and reboot the system when there are no calls in progress. This mode can be combined with the **Call Barring** options.
- **Timed** The same as **When Free** but waits for a specific time after which it then wait for there to be no calls in progress. The time is specified by the **Reboot Time**. This mode can be combined with the **Call Barring** options.
- **Reboot Time** This setting is used when the reboot mode **Timed** is selected. It sets the time for the system reboot. If the time is after midnight, the system's normal daily backup is canceled.
- **Call Barring** These settings can be used when the reboot mode **When Free** or **Timed** is selected. They bar the sending or receiving of any new calls.

Click **OK**. A service user name and password may be requested.

- If the service user name or password used do not valid, "**Access Denied**" is displayed.
- If the service user name used does not have rights to send a configuration or to request a reboot or merge, "Insufficient service user rights" is displayed.



- If the service user name used does not have operator rights to make the changes that have been made to the configuration, "**Insufficient operator rights. Operator cannot modify xxxx records**" is displayed.
- The warning will appear if the configuration being sent contain any errors indicated by a  icon in the error pane. The configuration can still be sent by selected **Yes**.
- The message **Failed to save the configuration data. (Internal error)** may indicate that the IP500 V2 system has booted using software other than that in its System SD card's primary folder.

### Sending Multiple Configurations

When Manager is running in Server Edition mode or SCN Management mode, it loads multiple configurations at the same time.

1. Click  in the main toolbar or select **File | Save Configuration** from the menu bar.
2. The menu displayed only shows details for those systems where the system configuration has been changed and needs to be sent back to the system.

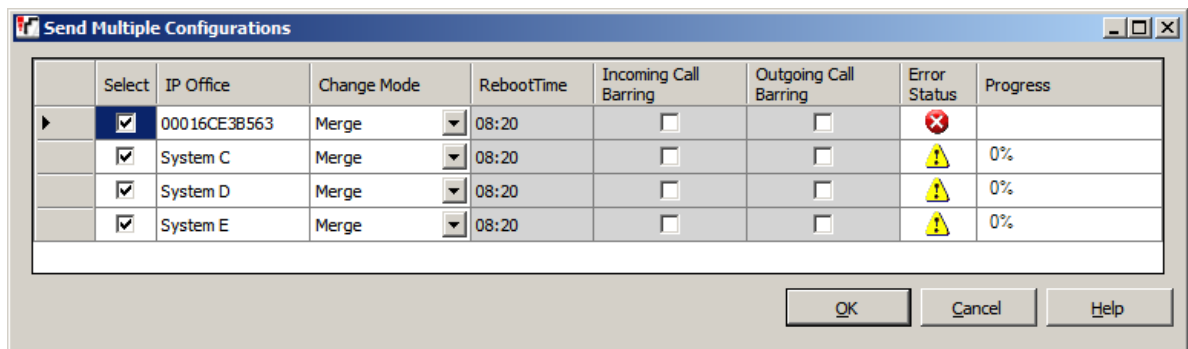

- **Select** By default all systems with configuration changes are selected. If you want to exclude a system from having its configuration updated, either deselect it or cancel the whole process.
- **Change Mode** If Manager thinks the changes made to the configuration settings are mergeable, it will select **Merge** by default, otherwise it will select **Immediate**.
- **Merge** Send the configuration settings without rebooting the system. This mode should only be used with settings that are mergeable. Refer to Mergeable Settings.
- **Immediate** Send the configuration and then reboot the system.
- **When Free** Send the configuration and reboot the system when there are no calls in progress. This mode can be combined with the **Incoming Call Barring** and **Outgoing Call Barring** options.
- **Store Offline** It is possible to add a reference for a Server Edition Secondary or for a Server Edition Expansion System to create a configuration file for that system even though it is not physically present. Store Offline saves that configuration on the Server Edition Primary in its file store. The same file is retrieved from there until such time as the physical server is present at which time you are prompted whether to use the stored file or the actual servers current configuration.

- **Timed** The same as **When Free** but waits for a specific time after which it then wait for there to be no calls in progress. The time is specified by the **Reboot Time**. This mode can be combined with the **Incoming Call Barring** and **Outgoing Call Barring** options.
- **Reboot Time** This setting is used when the reboot mode **Timed** is selected. It sets the time for the system reboot. If the time is after midnight, the system's normal daily backup is canceled.
- **Incoming Call Barring** This setting can be used when the reboot mode **When Free** or **Timed** is selected. It bars the receiving of any new calls.
- **Outgoing Call Barring** This setting can be used when the reboot mode **When Free** or **Timed** is selected. It bars the making of any new calls.

Click **OK**. The progress of the sending of each configuration is displayed.

#### Related links

[Editing Configuration Settings](#) on page 165

---

## Erasing the Configuration

### About this task

The system configuration settings can be erased. During this process, the system is rebooted and starts with a set of default settings. This process does not erase the security settings of the system.

Erasing the Configuration

### Procedure

1. Select **File | Advanced | Erase Configuration (Default)**.
2. Enter a valid user name and password.
3. The system will be rebooted.

#### Related links

[Editing Configuration Settings](#) on page 165

---

## Default Settings

The following applies to new systems and those defaulted using the Erase Configuration command. They also apply to IP500 V2 control units defaulted using the reset button on the rear of the unit (refer to the Installation manual for details of using the reset button).

### Mode

IP500 V2 control units can operate in a number of modes. The initial mode is determined by the type of System SD card fitted and the level of software.

**IP Office A-Law:** A system fitted with this type of card will default to A-Law telephony.

**IP Office U-Law:** A system fitted with this type of card will default to U-LAW telephony.

**Enterprise Branch:** Use this option for an SD card intended to be used with an IP Office system running in Enterprise Branch Mode. There is a separate SD card for Enterprise Branch. The Enterprise Branch SD card can only be used for Enterprise Branch operation and cannot be used to change modes to IP Office. You also cannot use or change an IP Office SD card for use with an Enterprise Branch system.

 **Warning:**

Do not re-purpose a Enterprise Branch card for use with any other IP Office mode. Doing so may damage the SD card and make it unusable for your Enterprise Branch system.

### Default Short Codes

For IP500 V2 control units, A-Law or U-Law operation is determined by the Feature Key dongle installed in the system. Depending on the variant, a default system will use different sets of default short codes. See the [Default System Short Code List](#) on page 821.

### Default Data Settings

When a new or defaulted control unit is switched on, it requests IP address information from a DHCP Server on the network. This operation will occur whether the LAN cable is plugged in or not.

If a DHCP server responds within approximately 10 seconds, the control unit defaults to being a DHCP client and uses the IP address information supplied by the DHCP server.

If no DHCP Server responds, the control unit still defaults to being the DHCP client but assumes the following default LAN addresses:

- For its LAN1 it allocates the IP address 192.168.42.1 and IP Mask 255.255.255.0.
- For its LAN2 if supported, it allocates the IP address 192.168.43.1 and IP Mask 255.255.255.0.

Once a control unit has obtained IP address and DHCP mode settings, it will retain those settings even if rebooted without a configuration file present on the System SD card. To fully remove the existing IP address and DHCP mode setting, the system must be defaulted using Manager.

### Default Security Settings

Security settings are held separately from the configuration settings and so are not defaulted by actions that default the configuration. To return the security settings to their default values the separate Erase Security Settings command should be used.

#### Default Standard Mode Telephony Configuration Settings

A hunt group **Main** is created with extension number 200. The first 16 extensions on the systems are added to the group.

All physical extensions ports are numbered from extension number 201 upwards. A matching user record for each extension is also created.

A default incoming call route for all voice calls is created, with the default hunt group Main as its destination.

## Editing Configuration Settings

A default incoming call route for data calls is created with the default RAS record DialIn as its destination.

All lines are defaulted to Incoming Group ID and Outgoing Group ID of 0.

Default short codes are created based on whether the system's locale is A-Law or U-Law.

Default Server Edition Telephony Configuration Settings

No users except **NoUser**.

All extensions are unnumbered.

No default hunt group or incoming calls routes are created.

All auto-create options are off by default.

### Related links

[Editing Configuration Settings](#) on page 165

# Chapter 11: Configuration Mode Field Descriptions

The following sections detail the configuration settings for the different record types within the system. Depending on the type and locale of the system some settings and tabs may be hidden as they are not applicable. Other settings may be grayed out. This indicates that the setting is either for information only or that another setting needs to be enabled first.

## Related links

[Configuration field display](#) on page 198

[BOOTP Record](#) on page 201

[Operator](#) on page 203

[System](#) on page 203

[Line](#) on page 279

[Control Unit](#) on page 395

[Extension](#) on page 396

[User](#) on page 413

[Group](#) on page 464

[Short Code](#) on page 488

[Service](#) on page 489

[RAS](#) on page 502

[Incoming Call Route](#) on page 504

[WAN Port](#) on page 514

[Directory Entry](#) on page 518

[Time Profile](#) on page 519

[Firewall Profile](#) on page 521

[IP Route](#) on page 525

[Account Code](#) on page 528

[Subscription](#) on page 530

[License](#) on page 531

[Tunnel](#) on page 537

[Auto Attendant](#) on page 543

[Authorization Codes](#) on page 548

[User Rights](#) on page 549

[ARS](#) on page 558

[Location](#) on page 562

---

## Configuration field display

The way that the system configuration settings are grouped and displayed in the navigation pane depends on whether Manager is running in its normal Standard mode or in Server Edition mode.

### Related links

[Configuration Mode Field Descriptions](#) on page 197

[Configuration field display in Standard mode](#) on page 198

[Configuration field display in Server Edition mode](#) on page 199

---

## Configuration field display in Standard mode

This order of display of different types of configuration record is used for Standard mode systems.



System Overall settings for the data and telephony operation of the system.



Line Settings for trunks and trunk channels within the system.



Control Unit Information summary of the system.



Extension Settings for extension ports.



User Settings for each system user. They may or may not be associated with an extension.



Hunt Group Collections of users to which calls can be directed for answer by any one of those users.



Short Code These are numbers which when dialed trigger specific features or are translated for external dialing. Short codes can be set at both the system wide level and locally for a particular system.



Service Configuration settings such as user names and passwords needed for connections to data services such as the Internet.



RAS Remote Access Service settings for connecting incoming data calls.



Incoming Call Route Records here are used to match incoming call details on external trunks to destinations on the system.



WAN Port Configuration settings for the WAN ports provided on some units.



Directory External names and numbers. Used for matching names to incoming calls and for dialing from user applications.



Time Profile Used to control when various functions are active.



Firewall Profile Use to control the types of data traffic that can cross into or out of the system.



IP Route These records are used to determine where data traffic on the system should be routed.



Account Code Used for call logging and to control the dialing of certain numbers.



License License keys are used to enable system features and applications.



Tunnel Used to created IPsec and L2TP data tunnels.



User Rights Provide templates to control the settings applied to associated users.



Auto Attendant Used when an Avaya memory card is installed in the control unit.



ARS Automatic Route Selection is used by to control outgoing external calls.



Authorization Codes Authorization codes are similar to account codes. However, unlike account codes which are usable by any user, each authorization code is only usable by a specific user or users associated with a specific set of user rights.

### Related links

[Configuration field display](#) on page 198

---

## Configuration field display in Server Edition mode

When Manager is being used in Server Edition mode, the navigation pane works in the same way as normal. However, the different types of configuration records are ordered and grouped differently. This reflects the fact that some types of record are automatically shared across all systems in the network.

### Solution settings

The first 8 types are records have special behaviors that are different from normal records stored in the configurations of individual systems in the network.

 **User** These records show settings for system users. Each user may or may not be associated with an extension. All the users configured on all systems are grouped here to allow easy configuration access. The individual user records are still stored in the configuration of the particular system on which the user was created and can also be accessed through that system's configuration settings. New users are created through the **User** settings of the system that hosts the user.

 **Hunt Group** These records are groups of users to which calls can be directed for answering by any one of those users. Hunt group records are stored in the configuration of the Primary Server but those hunt groups are advertised for use by all systems in the network.

 **Directory** External names and numbers. These records are used to match names to incoming calls and for making calls by name selection from the directory on phones or in applications. These directory records are stored in the configuration of the Primary Server. By default all other systems in the network automatically import a copy of the Primary Server system directory at regular intervals.

By default, the following types of records are all shared and replicated by each system in the network and cannot be set at an individual system level. That operation can be changed using the consolidation settings.

 **Short Code** These are numbers which when dialed trigger specific features or are translated for external dialing. These short codes are common to all systems in the network.

 **Incoming Call Route** Records set here are used to match incoming call details on external trunks to destinations. These incoming call routes are shared by all systems in the network.

 **Time Profile** Used to control when various functions are active. The time profiles set here are shared by all systems in the network.

 **Account Code** Used for call logging and to control the dialing of certain numbers. The account codes set here are shared by all systems in the network.

 **User Rights** Provide templates to control the settings applied to users associated with a particular set of user rights. These user rights are shared and replicated on all systems in the network.















### Individual system settings

In addition to the settings above, a range of other types of record can be configured for each individual system in the network. Visibility and configuration of **Short Code**, **Incoming Call Route**, **Time Profile**, **Account Code** and **User Rights** records is dependent on the consolidation settings of Manager.

 **System A** system icon is shown for each system in the network. That is, one for the Primary Server, one for the the Secondary Server if installed and one for each Expansion System (L) and



Expansion System (V2) systems. Each can be expanded to allow configuration of records that are particular to that system.

-  Line Settings for trunks and trunk channels within the system.
-  Control Unit Information summary of the system.
-  Extension Settings for extension ports.
-  User Settings for each system user. They may or may not be associated with an extension.
-  Short Code These are numbers which when dialed trigger specific features or are translated for external dialing.
-  Service Configuration settings such as user names and passwords needed for connections to data services such as the Internet.
-  RAS Remote Access Service settings for connecting incoming data calls.
-  WAN Port Configuration settings for the WAN ports provided on some units.
-  Firewall Profile Use to control the types of data traffic that can cross into or out of the system.
-  IP Route These records are used to determine where data traffic on the system should be routed.
-  License License keys are used to enable system features and applications.
-  Tunnel Used to create IPsec and L2TP data tunnels.
-  ARS Automatic Route Selection is used to control outgoing external calls.
-  Authorization Codes Authorization codes are similar to account codes. However, unlike account codes which are usable by any user, each authorization code is only usable by a specific user or users associated with a specific set of user rights.

#### Related links

[Configuration field display](#) on page 198

---

## BOOTP Record

Navigation: [BOOTP](#) | [BOOTP Record](#)

The BOOTP settings are used by the Manager application itself. They are not system configuration settings.

BOOTP is protocol used by devices to request software when restarting. It is used when upgrading the control unit within a system or when the core software within the control unit has been erased. When running, Manager can respond to BOOTP requests and, if it finds a matching BOOTP record for the system, provide the software file indicated by that record.

BOOTP records are not part of a system's configuration settings, they are items saved on the Manager PC. Normally Manager automatically creates a BOOTP record for each system with which it has communicated, up to a maximum of 50 records. However BOOTP records can be added and edited manually when necessary.

Field	Description
<b>File Location</b>	The location from which Manager provides files in response to BOOTP is its binaries directory. This can be changed using <b>File &gt; Change Working Directory</b> or <b>File &gt; Preferences &gt; Directories</b> .  This directory is also the directory used by Manager when providing files by TFTP.
<b>Disabling BOOTP</b>	Manager can be disabled from providing BOOTP support for any systems. Select <b>File &gt; Preferences &gt; Preferences &gt; Enable BOOTP and TFTP Server</b> .
<b>Enabled</b>	Default = Enabled  If unchecked, <b>BOOTP   BOOTP Record</b> support for the matching system from this Manager PC is disabled.
<b>System Name</b>	This field is not changeable. It shows the system name.
<b>MAC Address</b>	The MAC address of the system. The address can be obtained and or verified in a number of ways: <ul style="list-style-type: none"> <li>• When a system's configuration settings are loaded into Manager, it is shown as the Serial Number on the Unit form. On defaulted systems, it is also used as the system name.</li> <li>• If the system is requesting software, the MAC address is shown as part of the request in the status bar at the base of the Manager screen.</li> <li>• If the system can be pinged, it may be possible to obtain its MAC address using the command <b>arp -a &lt;ip address&gt;</b>.</li> </ul>
<b>IP Address</b>	The IP address of the system's LAN1.
<b>Filename</b>	The name of the .bin software file used by that type of control unit. To be transferred to the system, this file must exist in the Manager applications <b>Working Directory</b> .
<b>Time Offset</b>	: Default = 0.  In addition to performing BOOTP support for systems, the Manager application can also act as a time server (RFC868). This field sets the offset between the time on the PC running Manager and the time sent to the system in response to its time requests. The field is not used if a specific Time Server IP Address is set through the <b>System</b> form in the system's configuration settings.  Manager can be disabled from acting as an Internet Time (RFC868) server. Select <b>File &gt; Preferences &gt; Preferences</b> and uncheck <b>Enable time server</b> .

**Related links**

[Configuration Mode Field Descriptions](#) on page 197

---

## Operator

Operator records are not part of a system's configuration settings. They are used when a pre-Release 3.2 configuration is loaded to control what parts of a configuration can be edited.

Operator	View	Edit	New	Delete	Configuration Record Types
<b>Administrator</b>	Yes	Yes	Yes	Yes	All configuration records
<b>Manager</b>	Yes	Yes	Yes	Yes	View all. Other actions Extension, User, Hunt Group, Short Code, Service, RAS, Incoming Call Route, Directory, Time Profile, Firewall Profile, IP Route, Least Cost Routing, Account Code, ARS.
<b>Operator</b>	Yes	Yes	—	—	View all configuration records. Edit all except System, Line, Control Unit and Authorization Codes.

If an invalid operator is specified while receiving a configuration from a pre-3.2 system, the settings will be loaded using the Guest operator. This additional operator allows a read-only view.

**Related links**

[Configuration Mode Field Descriptions](#) on page 197

---

## System

Navigation: **System**

There is one System record for each system being managed. When managing multi system Server Edition or Small Community Network deployments, clicking on the **System** icon for a particular system displays a system inventory page for that system.

**Related links**

[Configuration Mode Field Descriptions](#) on page 197

[System](#) on page 204

[LAN1](#) on page 211

[LAN2](#) on page 225

- [DNS](#) on page 226
- [Voicemail](#) on page 226
- [Telephony](#) on page 233
- [Directory Services](#) on page 251
- [System Events](#) on page 256
- [SMTP](#) on page 263
- [System | SMDR](#) on page 264
- [VCM](#) on page 266
- [Integrated Contact Reporter](#) on page 268
- [VoIP](#) on page 269
- [VoIP Security](#) on page 271
- [Access Control Lists](#) on page 274
- [Dialer](#) on page 275
- [Contact Center](#) on page 277
- [Avaya Cloud Services](#) on page 278

## System

Navigation: **System | System**

### Additional configuration information

For additional information on time settings, see [System Date and Time](#) on page 596.

### Configuration settings

These settings are mergeable with the exception of **Locale** and **Favor RIP Routes over Static Routes**. Changing these settings requires a reboot of the system.

Field	Description
<b>Name</b>	<p>Default: = System MAC Address.</p> <p>A name to identify this system. This is typically used to identify the configuration by the location or customer's company name. Some features such as Gatekeeper require the system to have a name. This field is case sensitive and within any network of systems must be unique. Do not use &lt;, &gt;,  , \0, :, *, ?, . or /.</p>
<b>Contact Information</b>	<p>Default = Blank.</p> <p>This field is only be edited by service user with administrator rights. If Contact Information is entered, it will set the system under 'special control'.</p> <p>If the contact information is set using a standalone version of Manager, warnings that "This configuration is under special control" are given when the configuration is opened again. This can be used to warn other users of Manager that the system is being monitored for some specific reason and provide them with contact details of the person doing that monitoring.</p>

*Table continues...*

Field	Description
<b>Locale</b>	Sets default telephony and language settings based on the selection. It also sets various external line settings and so must be set correctly to ensure correct operation of the system. See <i>Avaya IP Office™ Platform Locale Settings</i> . For individual users, the system settings can be overridden through their own locale setting Select <b>User   User   Local</b> .
<b>Location</b>	Default = None.  Specify a location to associate the system with a physical location. Associating a system with a location allows emergency services to identify the source of an emergency call. The drop down list contains all locations that have been defined in the Location page.
<b>Customize Locale Settings</b>	
The <b>Customize</b> locale matches the Saudi Arabia locale but with the following additional controls shown below. For other locales, these are set on <b>System   Telephony   Tones and Music</b> .	
<b>Tone Plan</b>	Default = Tone Plan 1  The tone plan control tones and ringing patterns. The options are: <ul style="list-style-type: none"> <li>• <b>Tone Plan 1:</b> United States.</li> <li>• <b>Tone Plan 2:</b> United Kingdom.</li> <li>• <b>Tone Plan 3:</b> France.</li> <li>• <b>Tone Plan 4:</b> Germany.</li> <li>• <b>Tone Plan 5:</b> Spain.</li> </ul>
<b>CLI Type</b>	Used to set the CLI detection used for incoming analogue trunks. The options are: <ul style="list-style-type: none"> <li>• <b>DTMF</b></li> <li>• <b>FSK V23</b></li> <li>• <b>FSK BELL202</b></li> </ul>
<b>Device ID</b>	Server Edition Only. Displays the value set for <b>Device ID</b> on the System   System Events   Configuration tab. If an SSL VPN is configured, Avaya recommends that the Device ID match an SSL VPN service Account Name. Each SSL VPN service account name has an associated SSL VPN tunnel IP address. Having the displayed Device ID match an SSL VPN service account name helps identify a particular SSL VPN tunnel IP address to use for remotely managing IP Office.

*Table continues...*

Field	Description
<b>TFTP Server IP Address</b>	<p>Default = 0.0.0.0 (<i>Disabled. On Server Edition Systems, the default on Secondary and Expansion servers is the Primary Server address.</i>)</p> <p>If the <b>Phone File Server Type</b> below is set to <b>Custom</b>, this address is included as the TFTP file server address sent in the system's DHCP response to phones.</p> <p>The address 255.255.255.255 can be used to broadcast for the first available TFTP server on the network.</p> <p>Manager can act as a TFTP server and provides files from its configured binaries directory. This requires the application setting <b>File &gt; Preferences &gt; Preferences &gt; Enable BootP and TFTP Servers</b> to be enabled.</p> <p>On IP500 V2 systems, the LAN1 IP Address can be entered to specify the system's own memory card memory card as the TFTP file source. This requires the security setting <b>Security Settings &gt; Unsecured Interfaces &gt; Applications Controls &gt; TFTP Directory Read</b> to be enabled.</p>
<b>HTTP Server IP Address</b>	<p>Default = 0.0.0.0 (Disabled).</p> <p>This address, if set, is used in a number of scenarios:</p> <ul style="list-style-type: none"> <li>• <b>DHCP Responses:</b> If the <b>Phone File Server Type</b> below is set to <b>Custom</b>, this address is included as the HTTP file server address sent in the system's DHCP response to phones.</li> <li>• <b>HTTP Redirection:</b> If <b>HTTP Redirection</b> below is enabled, 9608, 9611, 9621, 9641, and H.323 phone binary file requests sent to the system are redirected to this address.</li> <li>• <b>H175 Phones/Vantage Phones:</b> Phone firmware file requests sent to the system from these types of phone always redirected to this address.</li> </ul>
<b>HTTP Server URI</b>	<p>Used by IP Office subscription systems. Redirects request to the file store used by the Customer Operations Manager cloud supporting the system.</p> <p>Requires the HTTP Server IP Address to be set to 0.0.0.0.</p>

*Table continues...*

Field	Description
<b>Phone File Server Type</b>	<p>Default = Memory Card (IP500 V2)/Disk (Linux system).</p> <p>For IP phones (H.323 and SIP) using the system as their DHCP server, the DHCP response can include the address of a file server from which the phone should request files. The setting of this field controls which address is used in the DHCP response. The options are:</p> <ul style="list-style-type: none"> <li>• <b>Custom:</b> The DHCP response the system provides to phones contains the addresses set in the <b>TFTP Server IP Address</b> and <b>HTTP Server IP Address</b> fields.</li> <li>• <b>Disk:</b> (<i>Linux systems only</i>) The system will respond to file requests from phones using files on its own hard disk. The DHCP response the system provides to phones contains its own LAN address as the TFTP and HTTP file server address.</li> <li>• <b>Memory Card:</b> (<i>IP500 V2 only</i>) The system will respond to file requests from phones using files on its own memory card. The DHCP response the system provides to phones contains its own LAN address as the TFTP and HTTP file server address. This is supported for up to 50 IP phones total.</li> <li>• <b>Manager:</b> (<i>IP500 V2 only</i>) The system will forward any H.323 phone file request to the configured <b>Manager PC IP Address</b> set below. The DHCP response the system provides to phones contains the system's LAN address as the HTTP file server address. <ul style="list-style-type: none"> <li>- HTTP-TFTP Relay is support when using Manager as the TFTP server (not supported by Linux based systems). This is done by setting the <b>TFTP Server IP Address</b> to the address of the Manager PC and the <b>HTTP Server IP Address</b> to the control unit IP address. This method is supported for up to 5 IP phones total.</li> </ul> </li> </ul>
<b>HTTP Redirection</b>	<p>Default = Off.</p> <p>This setting allows 9608, 9611, 9621, and 9641 phones to use the system as the file server when requesting their upgrade and settings files but have the requests for their large firmware files redirected to the address set by the <b>HTTP Server IP Address</b> field. This field is available when the <b>Phone File Server Type</b> is set to <b>Memory Card</b> or <b>Disk</b>.</p> <ul style="list-style-type: none"> <li>• H175 and Vantage phone firmware requests are always redirected to the <b>HTTPS Server IP Address</b> regardless of this and the <b>Phone File Server Type</b> settings.</li> </ul>
<b>Manager PC IP Address</b>	<p>Default = 0.0.0.0 (Broadcast).</p> <p>This address is used when the <b>Phone File Server Type</b> is set to <b>Manager</b>.</p>
<b>Avaya HTTP Clients Only</b>	<p>Default = Off.</p> <p>When selected, the system only responds to HTTP requests from sources it identifies as another system, an Avaya phone or application.</p>
<b>Enable SoftPhone HTTP Provisioning</b>	<p>Default = Off.</p> <p>This option must be enabled if the IP Office Video Softphone is being supported.</p>

*Table continues...*

Field	Description
<b>Use Preferred Phone Ports</b>	<p>Default = Off</p> <p>When selected, the system allows users to configure firewalls to block ports 80 and 443 if alternate mechanism for administration is provided. Phones can use either port 411 or 8411 if supported. Legacy phones that still require 80 and 443 can continue to use those ports through IP Office HTTP server. Where possible, HTTP requests from phones received on ports 80 and 443 must result in the phone proceed to use 8411/411, However, files continue to be served on the ports 80 and 443 to allow functionality of non-compliant phones. Configuration files served to phones, that are not behind an SBC, defines 8411 for HTTP and additionally 411 for TLS if the phone supports it and the phone is remote, or incoming request is already secure.</p> <p>When cleared, phones can continue to connect through all the four ports. DHCP provided HTTP IP addresses are served.</p>
<b>Favor RIP Routes over Static Routes</b>	<p>Default = Off</p> <p>RIP can be enabled on the system LAN1 and LAN2 interfaces and on specific Services. When this setting is on, the RIP route to a destination overrides any static route to the same destination in the system's IP Routes, regardless of the RIP route's metric. The only exception is RIP routes with a metric of 16 which are always ignored.</p> <p><b>* Note:</b></p> <p>If a previously learnt RIP route fails, the system applies a metric of 16 five minutes after the failure. When off, any RIP route to a destination for which a static route has been configured is ignored. This option is not supported on Linux based systems.</p>
<b>Messaging server</b>	<p>This field sets which service is used as the IM server for Avaya applications that support instant messaging. The following options are supported:</p> <ul style="list-style-type: none"> <li>• <b>one-X Portal</b> - Requires a one-X Portal server installed. This option does not support SSO login to clients.</li> <li>• <b>Avaya Spaces</b> - Requires the <b>System   Avaya Cloud Services</b> configured.</li> </ul>
<b>Automatic Backup</b>	<p>Default = On.</p> <p>This command is available with IP500 V2 systems. When selected, as part of its daily backup process, the system automatically copies the folders and files from the <b>System SD</b> card's <code>/primary</code> folder to its <code>/backup</code> folder. Any matching files and folders already present in the <code>/backup</code> folder are overwritten.</p>
<b>Provider</b>	<p>Default = Not visible. This field is visible only if the system has been branded by addition of a special license for a specific equipment provider. The branding is fixed, that is it remains even if the license is subsequently removed. The number shown is a unique reference to the particular equipment provider for whom the system has been branded. When branded, the equipment provider's name is displayed on idle phone displays and other provider related features are enabled.</p>

*Table continues...*



Field	Description
<b>Time Setting Config Source</b>	<p>Time and date settings are only shown for IP500 V2 based systems. The time and date for Linux based servers are set through the server's <b>Platform View</b> menus (<b>Settings &gt; System &gt; Date and Time</b>).</p> <p>For IP500 V2 systems, the time is either set manually, obtained using Time protocol (RFC868) requests or obtained using Network Time Protocol (RFC958) request. This field is used to select which method is used and to apply ancillary settings based on the selected method.</p> <ul style="list-style-type: none"> <li>• <b>None:</b> The system to not make any time requests. The system time and date can be set and changed using by a user with system phone rights. However, the system still automatically apply daylight saving changes to the manually set time.</li> <li>• <b>Voicemail Pro/Manager:</b> Both the Voicemail Pro service and the Manager program can act as RFC868 Time servers for the system. Use of other RFC868 server sources is not supported. They provide both the UTC time value and the local time as set on the PC. The system makes a request to the specified address following a reboot and every 8 hours afterwards. This option should not be used with a Unified Communication Module as in that scenario the voicemail server is being hosted by and getting its time from the IP Office.</li> <li>• <b>SNTP:</b> Use a list of SNTP servers to obtain the UTC time. The records in the list are used one at a time in order until there is a response. The system makes a request to the specified addresses following a reboot and every hour afterwards.</li> </ul>
<b>Time Settings — Voicemail Pro/Manager</b>	
These settings are shown for IP500 V2 based systems where the <b>Time Setting Config Source</b> has been set to <b>Voicemail Pro/Manager</b> .	
<b>IP Address</b>	<p>Default = 0.0.0.0 (Broadcast) The address to which the RFC868 request is sent. 0.0.0.0 means default operation. In this mode, following a reboot the control unit makes time requests on its LAN interfaces. It first makes a request to the IP address set and, if it receives no reply, then makes a broadcast request.</p> <p>If you are running Manager when the voicemail server starts, voicemail does not start as a time server. It is therefore recommended that you have no copy of Manager running when you start or restart the voicemail server. Manager can be disabled from acting as a RFC868 time server by deselecting the <b>Enable Time Server</b> option (<b>File &gt; Preferences &gt; Edit &gt; Preferences</b>).</p>
<b>Time Offset</b>	Default = 00:00. This value is not normally set as any time changes, including daylight saving changes, that occur on the PC will be matched by the system.
<b>Time Settings — None/SNTP</b>	
These settings are shown for IP500 V2 based systems where the <b>Time Setting Config Source</b> has been set to <b>None</b> or <b>SNTP</b> .	
<b>Time Server Address</b>	<p>Default = Blank</p> <p>Displayed when the <b>Time Setting Config Source</b> is set to <b>SNTP</b>. Enter a list of IP addresses, host names, or fully qualified domain names (FQDN) for the SNTP servers. Separate each record with a space. The use of broadcast addresses is not supported. The list is used in order of the records until a response is received.</p>

*Table continues...*

Field	Description
<b>Time Zone</b>	Select a time zone from the list. This sets the default time offset and DST to match the chosen time zone.
<b>Local Time Offset from UTC</b>	<p>Default is based on the currently selected time zone.</p> <p>This setting is used to set the local time difference from the UTC time value provided by an SNTP server. For example, if the system is 5 hours behind UTC, this field should be configured with <b>-05:00</b> to make the adjustment. The time offset can be adjusted in 15 minute increments. If also using the daylight time saving settings below, use this offset to set the non-DST local time.</p>
<b>Automatic DST</b>	<p>Default is based on the currently selected time zone.</p> <p>When set to On, the system automatically corrects for daylight saving time (DST) changes as configured in the <b>Clock Forward/Back Settings</b> below.</p>
<b>Clock Forward/Back Settings (Start Date — End Date (DST Offset))</b>	<p>Default is based on the currently selected time zone.</p> <p>Click <b>Edit</b> to configure the time and date for DST clock corrections. In the Daylight Time Settings window, you can configure the following information:</p> <ul style="list-style-type: none"> <li>• <b>DST Offset:</b> the number of hours to shift for DST.</li> <li>• <b>Clock Forward/Back:</b> Select <b>Go Forward</b> to set the date when the clock will move forward. Select <b>Go Backwards</b> to set the date when the clock will move backward.</li> <li>• <b>Local Time To Go Forward:</b> The time of day to move the clock forward or backward.</li> <li>• <b>Date for Clock Forward/Back:</b> Set the year, month and day for moving the clock forwards and backwards.</li> </ul> <p>Once you click <b>OK</b>, the forward and back dates, plus the DST offset, are displayed using the format <b>(Start Date — End Date (DST Offset))</b>.</p>
<b>File Writer IP Address</b>	<p>Default = 0.0.0.0 (Disabled)</p> <p>This field set the address of the PC allowed to send files to the System SD card installed in the system using HTTP or TFTP methods other than embedded file management.</p> <ul style="list-style-type: none"> <li>• On non-Linux based systems, this field sets the address of the PC allowed to send files to the memory card using HTTP or TFTP methods other than embedded file management.</li> <li>• For Linux based systems it is applied to non-embedded file management access to the <code>/opt/ipoffice</code> folder on the server.</li> </ul> <p>An address of 255.255.255.255 allows access from any address. If embedded file management is used, this address is overwritten by the address of the PC using embedded file management (unless set to 255.255.255.255).</p>
<b>Dongle Serial Number</b>	<p>Displayed for pre-Release 10.0 IP500 V2 systems using ADI licensing only. For system's using PLDS licensing, see the <b>PLDS Host ID (License &gt; License)</b>.</p> <p>This field is for information only. It shows the serial number of the feature key dongle against which the system last validated its licenses. <b>Local</b> is shown for a serial port, Smart Card or System SD feature key plugged directly into the control unit. <b>Remote</b> is shown for a parallel or USB feature key connected to a feature Key Server PC. The serial number is printed on the System SD card and prefixed with <b>FK</b>.</p>

*Table continues...*

Field	Description
<b>System Identification</b>	<p>Displayed for Linux based systems. This field is for information only.</p> <p>This is the unique system reference that is used to validate licenses issued for this particular system. For a physical server this is a unique value based on the server hardware. For a virtual server this value is based on several factors including the LAN1 and LAN2 IP addresses, the host name and the time zone. If any of those are changed, the System ID changes and any existing licenses become invalid.</p>
<b>AVPP IP Address</b>	<p>Default = 0.0.0.0 (Disabled)</p> <p>Where Avaya 3600 Series SpectraLink wireless handsets are being used with the system, this field is used to specify the IP address of the Avaya Voice Priority Processor (AVPP)</p>

### Related links

[System](#) on page 203

---

## LAN1

Navigation: **System | LAN1**

Used to configure the behavior of the services provided by the system's first LAN interface.

Up to 2 LAN's (LAN1 and LAN2) can be configured. The control unit has 2 RJ45 Ethernet ports, marked as LAN and WAN. These form a full-duplex managed layer-3 switch. Within the system configuration, the physical LAN port is LAN1, the physical WAN port is LAN2.

Configuring both interfaces with the same IP address on the same subnet is not supported. However, no warning is issued when this configuration is implemented.

### Related links

[System](#) on page 203

[LAN Settings](#) on page 211

[VoIP](#) on page 213

[Network Topology](#) on page 221

[DHCP Pools](#) on page 224

## LAN Settings

Navigation: **System | LAN | LAN Settings**

Used to set the general LAN settings for the LAN interface such as the IP address mode.

### Configuration Settings

These settings are not mergeable. Changes to these settings require a reboot of the system.

Field	Description
<b>IP Address</b>	Default = 192.168.42.1 or DHCP client.  This is the IP address of the Control Unit on LAN1. If the control unit is also acting as a DHCP server on the LAN, this address is the starting address for the DHCP address range.
<b>IP Mask</b>	Default = 255.255.255.0 or DHCP client.  This is the IP subnet mask used with the IP address.
<b>Primary Trans. IP Address</b>	Default = 0.0.0.0 (Disabled)  This setting is only available on control units that support a LAN2. Any incoming IP packets without a service or session are translated to this address if set.
<b>RIP Mode</b>	Default = None.  Routing Information Protocol (RIP) is a method by which network routers can exchange information about device locations and routes. Routes learnt using RIP are known as 'dynamic routes'. The system also supports 'static routes' though its IP Route records. For Server Edition systems this setting is only available on Expansion System (V2) systems. The options are: <ul style="list-style-type: none"> <li>• <b>None:</b> The LAN does not listen to or send RIP messages</li> <li>• <b>Listen Only (Passive):</b> Listen to RIP-1 and RIP-2 messages in order to learn RIP routes on the network.</li> <li>• <b>RIP1:</b> Listen to RIP-1 and RIP-2 messages and send RIP-1 responses as a sub-network broadcast.</li> <li>• <b>RIP2 Broadcast (RIP1 Compatibility):</b> Listen to RIP-1 and RIP-2 messages and send RIP-2 responses as a sub-network broadcast.</li> <li>• <b>RIP2 Multicast:</b> Listen to RIP-1 and RIP-2 messages and send RIP-2 responses to the RIP-2 multicast address.</li> </ul>
<b>Enable NAT</b>	Default = Off  This setting controls whether NAT should be used for IP traffic from LAN1 to LAN2. This setting should not be used on the same LAN interface as a connected WAN3 expansion module.
<b>Number of DHCP IP Addresses</b>	Default = 200 or DHCP client. Range = 1 to 999.  This defines the number of sequential IP addresses available for DHCP clients.

*Table continues...*

Field	Description
<b>DHCP Mode</b>	<p>Default = DHCP Client.</p> <p>This controls the control unit's DHCP mode for the LAN. When doing DHCP:</p> <ul style="list-style-type: none"> <li>• LAN devices are allocated addresses from the bottom of the available address range upwards.</li> <li>• Dial In users are allocated addresses from the top of the available range downwards.</li> <li>• If the control unit is acting as a DHCP server on LAN1 and LAN2, Dial in users are allocated their address from the LAN1 pool of addresses first.</li> </ul> <p>The options are:</p> <ul style="list-style-type: none"> <li>• <b>Server:</b> When this option is selected, the system will act as a DHCP Server on this LAN, allocating address to other devices on the network and to PPP Dial in users.</li> <li>• <b>Disabled</b> When this option is selected, the system will not use DHCP. It will not act as a DHCP server and it will not request an IP address from a DHCP server on this LAN.</li> <li>• <b>Dial In</b> When this option is selected, the system will allocate DHCP addresses to PPP Dial In users only. On systems using DHCP pools, only addresses from a pool on the same subnet as the system's own LAN address will be used.</li> <li>• <b>Client</b> When this option is selected, the system will request its IP Address and IP Mask from a DHCP server on the LAN.</li> </ul> <p> <b>Note:</b></p> <p>Do not use this option with a limited time lease line.</p> <ul style="list-style-type: none"> <li>• <b>Advanced:</b> The system can be configured with a number of DHCP Pools from which it can issue IP addresses.</li> </ul>

### Related links

[LAN1](#) on page 211

## VoIP

Navigation: **System | LAN | VoIP**

### Configuration settings

Used to set the system defaults for VoIP operation on the LAN interface.

The following settings are mergeable:

- **Auto-create Extn**
- **Auto-create User**
- **H.323 Signalling over TLS**
- **Remote Call Signalling Port**
- **Auto-create Extn/User**

- **Enable RTCP Monitoring on Port 5005**
- **RTCP collector IP address for phones**
- **Scope**
- **Initial keepalives**
- **Periodic timeout**
- **VLAN**
- **1100 Voice VLAN Site Specific Option Number (SSON)**
- **1100 Voice VLAN IDs**

The remaining settings are not mergeable. Changes to these settings requires a reboot of the system.

Field	Description
<b>H.323 Gatekeeper Enable</b> Default = Off This settings enables gatekeeper operation.	
<b>H.323 Signalling over TLS</b>	Default = Disabled. For hosted deployments, default = Preferred. When enabled, TLS is used to secure the registration and call signalling communication between IP Office and endpoints that support TLS. The H.323 phones that support TLS are 9608, 9611, 9621, and 9641 running firmware version 6.6 or higher. When enabled, certificate information is configured in the <code>46xxSettings.txt</code> file on IP Office and automatically downloaded to the phone. When IP Office receives a request from the phone for an identity certificate, IP Office searches it's trusted certificate store and finds the root CA that issued it's identity certificate. IP Office then provides the root CA as an auto-generated certificate file named <code>Root-CA-xxxxxxxx.pem</code> . For information on IP Office certificates, see <b>Security Mode   System   Certificates</b> . The options are: <ul style="list-style-type: none"> <li>• <b>Disabled:</b> TLS is not used.</li> <li>• <b>Preferred:</b> Use TLS when connecting to a phone that supports TLS.</li> <li>• <b>Enforced:</b> TLS must be used. If the phone does not support TLS, the connection is rejected.</li> </ul> When set to <b>Enforced</b> , the <b>Remote Call Signalling Port</b> setting is disabled. If TLS security is enabled ( <b>Enforced</b> or <b>Preferred</b> ), it is recommended that you enable a matching level of media security on <b>System   VoIP Security</b> .

*Table continues...*



Field	Description
<b>H.323 Remote Extn Enable</b>	<p>Default = Off.</p> <p>The system can be configured to support remote H.323 extensions in the case where NAT is used in the connection path. This could be the case where the IP Office is located behind a corporate NAT/Firewall router and/or the H.323 phone is located behind residential NAT enable router.</p> <p>The use of this option and the interaction and configuration of external third party elements is beyond the scope this help file.</p> <p>In the case where the public IP address of the corporate router is unknown, the LAN's Network Topology settings should be used to configure a STUN Server. Enabling <b>H.323 Remote Extn Enable</b> allows configuration of the <b>RTP Port number Range (NAT)</b> settings.</p> <p>Currently, only 9600 Series phones are supported as H.323 remote extensions.</p>
<b>Auto-create Extn</b>	<p>Default = Off</p> <p>The field to set up auto creation of extensions for H.323 phones registering themselves with the System as their gatekeeper. If selected, the system displays the <b>Auto Create Extension Password</b> window prompting you to type a Password and Confirm Password. This password is used for subsequent auto creation of extensions. A message <code>H.323 Auto-Create Extension option is active</code> is flashed next to the <b>Auto Create Extension</b> field till the option is cleared. SIP Extensions use a separate setting, see below. This setting is not supported on systems configured to use WebLM server licensing.</p> <p>If using resilience backup to support Avaya IP phones, <b>Auto-create Extn</b> and <b>Auto-create User</b> should not be left enabled after initial configuration or any subsequent addition of new extensions and users. Leaving auto-create options enabled on a system that is a failover target may cause duplicate extension/user records on the multi-site network under multiple failure scenarios.</p> <p>For security, any auto-create settings set to On are automatically set to Off after 24 hours.</p>
<b>SIP Trunks Enable</b>	<p>Default = On.</p> <p>This settings enables support of SIP trunks. It also requires entry of <b>SIP Trunk Channels</b> licenses.</p> <p>Enabling <b>SIP Trunks Enable</b> allows configuration of the <b>RTP Port number Range (NAT)</b> settings.</p>
<p><b>SIP Registrar Enable</b></p> <p>Default = Off.</p> <p>Used to set the system parameters for the system acting as a SIP Registrar to which SIP endpoint devices can register. Separate SIP registrars can be configured on LAN1 and LAN2. Registration of a SIP endpoint requires an available <b>IP Endpoints</b> license. SIP endpoints are also still subject to the extension capacity limits of the system.</p>	

*Table continues...*

Field	Description
<b>SIP Remote Extn Enable</b>	<p>Default = Off.</p> <p>The system can be configured to support remote SIP extensions in the case where NAT is used in the connection path. This could be the case where the IP Office is located behind a corporate NAT/Firewall router and/or the SIP phone is located behind residential NAT enable router.</p> <ul style="list-style-type: none"> <li>• This option cannot be enabled on both LAN1 and LAN2.</li> <li>• The use of this option and the interaction and configuration of external third party elements is beyond the scope this help file.</li> </ul> <p>In the case where the public IP address of the corporate router is unknown, the LAN's Network Topology settings should be used to configure a STUN Server. Enabling <b>SIP Remote Extn Enable</b> allows configuration of:</p> <ul style="list-style-type: none"> <li>• the <b>Remote UDP Port, Remote TCP Port, Remote TLS Port</b> settings</li> <li>• the <b>Port Number Range (NAT)</b> settings</li> </ul> <p>Currently, supported remote SIP extensions are B199, J100 series, K100 Series, Avaya Workplace Client, one-X Mobile iOS and one-X Mobile Android SIP clients.</p>
<b>Allowed SIP User agents</b>	<p>Default = Block blacklist only</p> <p>The drop-down menu to select which SIP devices are allowed to register with the IP Office system. Depending on the selection, IP Office allows registration of SIP User Agents specified using the <b>System &gt; VOIP &gt; Access Control Lists</b> tab. The options are:</p> <ul style="list-style-type: none"> <li>• <b>Allow All:</b> Do not block any devices based on the UI strings.</li> <li>• <b>Block Blacklist Only:</b> Block devices whose UA string is listed in the <b>SIP UA Blacklist</b>.</li> <li>• <b>Avaya Clients &amp; Whitelisted:</b> Only allow devices with an Avaya UA string or whose UA string is listed in the <b>SIP UA Whitelist</b>.</li> <li>• <b>Avaya Clients Only:</b> Only allow clients with an Avaya UA string.</li> <li>• <b>Whitelisted only:</b> Only allow devices whose UA string is listed in the <b>SIP UA Whitelist</b>.</li> </ul>
<b>Auto-create Extn/User</b>	<p>Default = Off.</p> <p>The field to set up auto creation of extensions for SIP phones registering themselves with the SIP registrar. If selected, the system displays the <b>Auto Create Extension Password</b> window prompting you to type a Password and Confirm Password. This password is used for subsequent auto creation of extensions. A message <code>SIP Auto-Create Extension/User option is active</code> is flashed next to the <b>Auto Create Extension/User</b> field till the option is cleared. This setting is not supported on systems configured to use WebLM server licensing.</p> <p>For security, any auto-create settings set to On are automatically set to Off after 24 hours.</p>

*Table continues...*



Field	Description
<b>SIP Domain Name</b>	<p>Default = Blank</p> <p>This value is used by SIP endpoints for registration with the IP Office system. SIP endpoints register with IP Office using their SIP address that consists of their phone number and IP Office SIP domain. Since IP Office does not allow calls from unauthorized entities, the SIP domain does not need to be resolvable. However, the SIP domain should be associated with FQDN (Fully Qualified Domain Name) for security purposes. The entry should match the domain suffix part of the SIP Registrar FQDN below, for example, <code>example.com</code>. If the field is left blank, registration uses the LAN 1, LAN2, or public IP address.</p> <p> <b>Note:</b></p> <p>For Avaya SIP telephones supported for resilience, the <b>SIP Domain Name</b> must be common to all systems providing resilience.</p>
<b>SIP Registrar FQDN</b>	<p>Default = Blank</p> <p>This is the SIP registrar fully qualified domain name, for example, <code>server1.example.com</code>, to which the SIP endpoint should send its registration request. This address must be resolvable by DNS to the IP address of the IP Office system or to the IP address, such as that of an Avaya SBCE, through which the SIP endpoints reach the IP Office system.</p>
<b>Challenge Expiry Time (secs)</b>	<p>Default = 10.</p> <p>The challenge expiry time is used during SIP extension registration. When a device registers, the system SIP Registrar will send a challenge back to the device and waits for an appropriate response. If the response is not received within this timeout the registration is failed.</p>
<b>Layer 4 Protocol</b>	<p>Default = TCP and UDP. This field is used to select which protocols are supported for SIP connections: TCP, UDP, or TLS.</p> <ul style="list-style-type: none"> <li>• <b>UDP Port:</b> Default = 5060. The port to use for SIP UDP support if UDP is selected as the <b>Layer 4 Protocol</b> above.</li> <li>• <b>TCP Port:</b> Default = 5060. The port to use for SIP TCP support if TCP is selected as the <b>Layer 4 Protocol</b> above.</li> <li>• <b>TLS Port:</b> Default = 5061. The port to use for SIP TLS support.</li> <li>• <b>Remote UDP Port:</b> Default = 5060. The port to use for SIP UDP support if UDP is selected as the Layer 4 Protocol for remote SIP extension.</li> <li>• <b>Remote TCP Port:</b> Default = 5060. The port to use for SIP TCP support if TCP is selected as the Layer 4 Protocol for remote SIP extension.</li> <li>• <b>Remote TLS Port:</b> Default = 5061. The port to use for SIP TLS support if TLS is selected as the Layer 4 Protocol for remote SIP extension.</li> </ul> <p> <b>Note:</b></p> <p>The E129 phone does not support UDP. In IP Office release 10 and higher, UDP support has been removed from the configuration file sent to the phone. For the E129 phone, you must enable TCP.</p>

*Table continues...*

Field	Description
<b>RTP</b>	
<b>Port Number Range</b>	<p>For each VoIP call, a receive port for incoming Real Time Protocol (RTP) traffic is selected from a defined range of possible ports, using the even numbers in that range. The Real Time Control Protocol (RTCP) traffic for the same call uses the RTP port number plus 1, that is the odd numbers. For control units and Avaya H.323 IP phones, the default port range used is 49152 to 53246. On some installations, it may be a requirement to change or restrict the port range used. It is recommended that only port numbers between 49152 and 65535 are used, that being the range defined by the Internet Assigned Numbers Authority (IANA) for dynamic usage.</p> <p> <b>Important:</b></p> <p>The minimum and maximum settings of the port range should only be adjusted after careful consideration of the customer network configuration and existing port usage. For pre-Release 8.1 systems, the gap between the minimum and maximum port values must be at least 1024. For Release 8.1 and higher, the gap between the minimum and maximum port values must be at least 254.</p>
<b>Port Range (minimum)</b>	<p>IP500 V2 default = 46750. Range = 46750 to 50750.</p> <p>Linux default = 40750. Range = 40750 to 50750</p> <p>This sets the lower limit for the RTP port numbers used by the system.</p>
<b>Port Range (maximum)</b>	<p>IP500 V2 default = 50750. Range = 46750 to 50750.</p> <p>Linux default = 50750. Range = 47000 to 50750</p> <p>This sets the upper limit for the RTP port numbers used by the system.</p>
<b>Port Number Range (NAT)</b>	
<p>These settings are available when either <b>H.323 Remote Extn Enable</b>, <b>SIP Trunks Enable</b>, or <b>SIP Remote Extn Enable</b> is set to On.</p> <p>This option is not supported if <b>System   LAN   Network Topology   Firewall/NAT Type</b> is set to <b>Symmetric Firewall</b> or <b>Open Internet</b>.</p>	
<b>Port Range (minimum)</b>	<p>IP500 V2 default = 46750. Range = 46750 to 50750.</p> <p>Linux default = 40750. Range = 40750 to 50750</p> <p>This sets the lower limit for the RTP port numbers used by the system.</p>
<b>Port Range (maximum)</b>	<p>IP500 V2 default = 50750. Range = 46750 to 50750.</p> <p>Linux default = 50750. Range = 40750 to 50750</p> <p>This sets the upper limit for the RTP port numbers used by the system.</p>

*Table continues...*

Field	Description
<b>Enable RTCP Monitor On Port 5005</b>	<p>Default = On.</p> <p>For 1600, 4600, 5600 and 9600 Series H.323 phones, the system can collect VoIP QoS (Quality of Service) data from the phones. For other phones, including non-IP phones, it can collect QoS data for calls if they use a VCM channel. The QoS data collected by the system is displayed by the System Status Application.</p> <p>This setting is mergeable. However, it only affects H.323 phones when they register with the system. Therefore, any change to this setting requires H.323 phones that have already been registered to be rebooted. Avaya H.323 phones can be remotely rebooted using the System Status Application.</p> <p>The QoS data collected includes: RTP IP Address, Codec, Connection Type, Round Trip Delay, Receive Jitter, Receive Packet Loss.</p> <p>This setting is not the same as the RTCPMON option within Avaya H.323 phone settings. The system does not support the RTCPMON option.</p>
<b>RTCP collector IP address for phones</b>	<p>Default = Blank.</p> <p>This setting is used to manually set the destination for the RTCP Monitor data described above <b>Enable RTCP Monitor On Port 5005</b> field above. This enables you to send the data collected to a third party QoS monitoring application.</p> <p>The <b>Enable RTCP Monitor On Port 5005</b> must be turned Off to enable this field. Changes to this setting requires a reboot of the phones.</p>
<b>Keepalives</b>	
<p>These settings are used to facilitate NAT traversal of RTP/RTCP packets and are applicable to all RTP/RTCP session on the network interface. You should enable these settings on interfaces connected to NAT devices if you are using SIP trunks and/or H323 and SIP remote workers.</p>	
<b>Scope</b>	<p>Default = Disabled</p> <p>Select whether the sending of keepalive packets should be disabled or sent for RTP or for both RTP and RTCP.</p>
<b>Periodic timeout</b>	<p>Default = 0 (Off). Range = 0 to 180 seconds.</p> <p>Sets how long the system will wait before sending a keepalive if no other packets of the select <b>SCOPE</b> are seen.</p>
<b>Initial keepalives</b>	<p>Default = Disabled.</p> <p>If enabled, keepalives can also been sent during the initial connection setup.</p>

*Table continues...*

Field	Description
<b>DiffServ Settings</b>	
<p>When transporting voice over low speed links it is possible for normal data packets (1500 byte packets) to prevent or delay voice packets (typically 67 or 31 bytes) from getting across the link. This can cause unacceptable speech quality. Therefore it is important that all traffic routers and switches in a network to have some form of Quality of Service mechanism (QoS). QoS routers are essential to ensure low speech latency and to maintain sufficient audible quality.</p> <p>The system applies the DiffServ settings to outgoing traffic on any SIP lines which have <b>Line   SIP Line   Transport   Use Network Topology Info</b> set to match the LAN interface.</p> <p>The system supports the DiffServ (RFC2474) QoS mechanism. This uses a Type of Service (ToS) field in the IP packet header.</p> <p>The hex and decimal entry fields for the following values are linked, the hex value being equal to the decimal multiplied by 4.</p>	
<b>DSCP (Hex)</b>	<p>Default = B8 (Hex)/46 (decimal). Range = 00 to FF (Hex)/0 to 63 (decimal)</p> <p>The DiffServ Code Point (DSCP) setting applied to VoIP calls. By default, the same setting is used for audio and video. If desired, you can configure separate values for audio and video. For correct operation, especially over WAN links, the same value should be set at both ends.</p>
<b>Video DSCP (Hex)</b>	<p>Default = B8 (Hex)/46 (decimal). Range = 00 to FF (Hex)/0 to 63 (decimal)</p> <p>The DiffServ Code Point (DSCP) setting applied to video VoIP calls. For correct operation, especially over WAN links, the same value should be set at both ends.</p>
<b>DSCP Mask (Hex)</b>	<p>Default = FC (Hex)/63 (decimal). Range = 00 to FF (Hex)/0 to 63 (decimal)</p> <p>Allows a mask to be applied to packets for the DSCP value.</p>
<b>SIG DSCP (Hex)</b>	<p>Default = 88 (Hex)/34 (decimal). Range = 00 to FF (Hex)/0 to 63 (decimal)</p> <p>This setting is used to prioritize VoIP call signaling.</p>
<b>DHCP Settings</b>	
<b>Primary Site Specific Option Number (4600/5600)</b>	<p>Default = 176. Range = 128 to 254.</p> <p>A site specific option number (SSON) is used as part of DHCP to request additional information. 176 is the default SSON used by 4600 Series and 5600 Series IP phones.</p>
<b>Secondary Site Specific Option Number (1600/9600)</b>	<p>Default = 242. Range = 128 to 254.</p> <p>Similar to the primary SSON. 242 is the default SSON used by 1600 and 9600 Series IP phones requesting installation settings via DHCP.</p>
<b>VLAN</b>	<p>Default = Not present. This option is applied to H.323 phones using the system for DHCP support. If set to <b>Disabled</b>, the L2Q value indicated to phones in the DHCP response is 2 (disabled). If set to <b>Not Present</b>, no L2Q value is included in the DHCP response.</p>
<b>1100 Voice VLAN Site Specific Option Number (SSON)</b>	<p>Default = 232.</p> <p>This is the SSON used for responses to 1100/1200 Series phones using the system for DHCP.</p>

Table continues...

Field	Description
<b>1100 Voice VLAN IDs</b>	Default = Blank.  For 1100/1200 phone being supported by DHCP, this field sets the VLAN ID that should be provided if necessary. Multiple IDs (up to 10) can be added, each separated by a + sign.

### Related links

[LAN1](#) on page 211

## Network Topology

Navigation: **System | LAN | Network Topology**

STUN (Simple Traversal of UDP through NAT) is a mechanism used to overcome the effect of NAT firewalls. The network address translation (NAT) action performed by this type of firewall can have negative effects on VoIP calls.

Test packets are sent by the system to the address of the external STUN server, those packets crossing the firewall in the process. The STUN server replies and includes copies of the packets it received in the reply. By comparing the packet sent and received, it is possible for the system to determine the type of NAT firewall and to modify future packets to overcome the effects of the firewall.

These settings are used for SIP trunk connections from the LAN, H.323 and SIP remote extensions. For further details of system SIP operation refer to the SIP Line section. The use of STUN is unnecessary if the SIP ITSP uses a Session Border Controller (SBC). Use of SIP requires entry of SIP Trunk Channels licenses.

The following fields can be completed either manually or the system can attempt to automatically discover the appropriate values. To complete the fields automatically, only the STUN Server IP Address is required. STUN operation is then tested by clicking Run STUN. If successful the remaining fields are filled with the results.

### Configuration Settings



These settings are not mergeable. Changes to these settings require a reboot of the system.

Field	Description
<b>STUN Server IP Address</b>	Default = Blank  Enter the IP address or fully qualified domain name (FQDN) of the SIP ITSP's STUN server. The system will send basic SIP messages to this destination and from data inserted into the replies can try to determine the type NAT changes being applied by any firewall between it and the ITSP.
<b>STUN Port</b>	Default = 3478.  Defines the port to which STUN requests are sent if STUN is used.

*Table continues...*

Field	Description
<b>Firewall/NAT Type</b>	<p>Default = Unknown</p> <p>The settings here reflect different types of network firewalls. The options are:</p> <ul style="list-style-type: none"> <li>• <b>Blocking Firewall</b></li> <li>• <b>Symmetric Firewall:</b> SIP packets are unchanged but ports need to be opened and kept open with keep-alives. If this type of NAT is detected or manually selected, a warning 'Communication is not possible unless the STUN server is supported on same IP address as the ITSP' will be displayed as part of the manager validation.</li> <li>• <b>Open Internet:</b> No action required. If this mode is selected, settings obtained by STUN lookups are ignored. The IP address used is that of the system LAN interface.</li> <li>• <b>Symmetric NAT:</b> A symmetric NAT is one where all requests from the same internal IP address and port, to a specific destination IP address and port, are mapped to the same external IP address and port. If the same host sends a packet with the same source address and port, but to a different destination, a different mapping is used. Furthermore, only the external host that receives a packet can send a UDP packet back to the internal host. SIP Packets need to be mapped but STUN will not provide the correct information unless the IP address on the STUN server is the same as the ITSP Host. If this type of NAT/Firewall is detected or manually selected, a warning 'Communication is not possible unless the STUN server is supported on same IP address as the ITSP' will be displayed as part of the manager validation.</li> <li>• <b>Full Cone NAT:</b> A full cone NAT is one where all requests from the same internal IP address and port are mapped to the same external IP address and port. Furthermore, any external host can send a packet to the internal host, by sending a packet to the mapped external address. SIP packets need to be mapped to NAT address and Port; any Host in the internet can call in on the open port, that is the local info in the SDP will apply to multiple ITSP Hosts. No warning will be displayed for this type of NAT because the system has sufficient information to make the connection).</li> <li>• <b>Restricted Cone NAT:</b> A restricted cone NAT is one where all requests from the same internal IP address and port are mapped to the same external IP address and port. Unlike a full cone NAT, an external host (with IP address X) can send a packet to the internal host only if the internal host had previously sent a packet to IP address X. SIP packets needs to be mapped. Responses from hosts are restricted to those that a packet has been sent to. So if multiple ITSP hosts are to be supported, a keep alive will need to be sent to each host. If this type of NAT/ Firewall is detected or manually selected, no warning will be displayed for this type of NAT.</li> <li>• <b>Port Restricted Cone NAT:</b> A port restricted cone NAT is like a restricted cone NAT, but the restriction includes port numbers. Specifically, an external host can send a packet, with source IP address X and source port P, to the internal host only if the internal host had previously sent a packet to IP address X and port P. SIP packets needs to be mapped. Keep-alives must be sent to all ports that will be the source of a packet for each ITSP host IP address. If this type of NAT/Firewall</li> </ul>

*Table continues...*

Field	Description
	<p>is detected or manually selected, no warning will be displayed for this type of NAT. However, some Port Restricted NAT's have been found to be more symmetric in behavior, creating a separate binding for each opened Port, if this is the case the manager will display a warning 'Communication is not possible unless the STUN server is supported on same IP address as the ITSP' as part of the manager validation.</p> <ul style="list-style-type: none"> <li>• <b>Static Port Block:</b> Use the RTP Port Number Range specified on the VoIP tab without STUN translation. Those ports must be fixed as open on any NAT firewall involved</li> <li>• <b>One-To-One NAT:</b> This setting supports IP Office cloud deployments where the Primary server is behind a NAT that performs IP address translation but not port mappings. All required ports must be open on the NAT.</li> </ul> <p>When set to <b>One-To-One NAT</b>, the following configuration settings are applied and cannot be edited.</p> <ul style="list-style-type: none"> <li>- The <b>LAN   Network Topology   Public Port</b> values are set to 0.</li> <li>- <b>LAN   VoIP   SIP Registrar Enable</b> remote protocol port values are set to equal their corresponding local protocol port values.</li> <li>- The <b>LAN   VoIP   RTP   Port Number Range (NAT) Minimum</b> and <b>Maximum</b> values are set to equal the corresponding <b>Port Number Range</b> values.</li> </ul> <ul style="list-style-type: none"> <li>• <b>Unknown</b></li> </ul>
<b>Binding Refresh Time (seconds)</b>	<p>Default = 0 (Never). Range = 0 to 3600 seconds.</p> <p>Having established which TCP/UDP port number to use, through either automatic or manual configuration, the system can send recurring 'SIP OPTIONS requests' to the remote proxy terminating the trunk. Those requests will keep the port open through the firewall. Requests are sent every x seconds as configured by this field.</p> <p> <b>Note:</b></p> <p>If a binding refresh time has not been set you may experience problems receiving inbound SIP calls as they are unable to get through the Firewall. In these circumstances make sure that this value has been configured.</p>
<b>Public IP Address</b>	<p>Default = 0.0.0.0 This value is either entered manually or discovered by the Run STUN process. If no address is set, the system LAN1 address is used.</p>
<b>Public Port</b>	<p>Default = 0</p> <p>The public port value for <b>UDP</b>, <b>TCP</b>, and <b>TLS</b>. For each protocol, this value is either entered manually or discovered by the Run STUN process.</p>
<b>Run STUN</b>	<p>This button tests STUN operation between the system LAN and the STUN Server IP Address set above. If successful the results are used to automatically fill the remaining fields with appropriate values discovered by the system. Before using Run STUN the SIP trunk must be configured.</p> <p>When this option is used, a  information icon is shown against the fields to indicate that the values were automatically discovered rather than manually entered.</p>

*Table continues...*

Field	Description
<b>Run STUN on startup</b>	<p>Default = Off</p> <p>This option is used in conjunction with values automatically discovered using Run STUN. When selected, the system will rerun STUN discovery whenever the system is rebooted or connection failure to the SIP server occurs.</p>

### Related links

[LAN1](#) on page 211

## DHCP Pools

Navigation: **System | LAN | DHCP Pools**

DHCP pools allows for the configuration of of IP address pools for allocation by the system when acting as a DHCP server. On an IP500 V2 system, you can configure up to 8 pools. On Server Edition Linux systems, you can configure up to 64 pools.

By default the DHCP settings (IP Address, IP Mask and Number of DHCP IP Addresses) set on the LAN Settings tab are reflected by the first pool here. For support of PPP Dial In address requests, at least one of the pools must be on the same subnet as the system's LAN. Only addresses from a pool on the same subnet as the system's own LAN address will be used for PPP Dial In.

These settings are mergeable. However, the following actions require a merge with service disruption:

- Changing the **Start Address**, **Subnet Mask** or **Default Router** value for an existing DHCP Pool of addresses.
- Decreasing **Pool Size** for an existing DHCP Pool of addresses.
- Deleting an existing DHCP Pool of addresses.

When these actions are performed, the DHCP (Server or DialIn) is re-initialized which triggers a reboot of the Avaya DHCP Clients (H.323 and SIP) in order to force the Avaya DHCP clients to renew their IP address lease and apply the new settings. For the remaining Avaya and non-Avaya DHCP clients, you must manually reboot the devices in order to force the IP Addresses lease renewal. Otherwise, the devices continue to use the allocated IP addresses until the IP addresses lease time out expires. IP address lease time out is set to three days.

The DHCP server re-initialization causes a reboot of all Avaya DHCP clients and not only of the DHCP clients that have obtained an IP Address within the modified DHCP Pool IP range. Note that IP Office supports phone reboot only for E129 and B179 SIP phone models.



Field	Description
<b>Apply to Avaya IP Phones Only</b>	<p>Default = Off.</p> <p>When set to On, the DHCP addresses are only used for requests from Avaya IP phones. Other devices connected to the system LAN will have to use static addresses or obtain their address from another DHCP server.</p> <p>In addition to the above control, Avaya IP phones will only complete DHCP against a DHCP server configured to supports a Site Specific Option Number (SSON) that matches that set on the phone. The SSON numbers supported by the system DHCP are set on the VoIP sub-tab.</p> <p>Once set to On and the configuration has been merged, you must manually reboot the non-Avaya DHCP Client devices in order to force IP addresses lease renewal and to make the settings new values effective. Otherwise the non-Avaya DHCP Client devices will continue to use the allocated IP addresses until the IP addresses lease time out expires. IP address lease time out is set to three days.</p>
<b>DHCP Pool</b>	<p>Up to 8 pools can be added. The first pool matches the IP Address, IP Mask and Number of DHCP IP Addresses on the LAN Settings sub-tab. When adding or editing pools, Manager will attempt to warn about overlaps and conflicts between pools. The options are:</p> <ul style="list-style-type: none"> <li>• <b>Start Address</b> Sets the first address in the pool.</li> <li>• <b>Subnet Mask:</b> Default = 255.255.255.0 Sets the subnet mask for addresses issued from the pool.</li> <li>• <b>Default Router:</b> Default = 0.0.0.0 For pools issuing IP addresses on the same subnet as the system LAN's, <b>0.0.0.0</b> instructs the system to determined the actual default router address to issue by matching the IP address/subnet mask being issued in the IP Routing table. This matches the default behaviour used by systems without multiple pools. For pools issuing addresses not on the same subnet as the system LAN's, the default router should be set to the correct value for devices on that subnet.</li> <li>• <b>Pool Size:</b> Default = 0 Set the number of DHCP client addresses available in the pool.</li> </ul>

### Related links

[LAN1](#) on page 211

---

## LAN2

Navigation: **System | LAN2**

These settings used to configure the system's second LAN interface. The fields available for LAN2 are the same as for LAN1 except for the following additional field.

These settings are not mergeable. Changes to these settings will require a reboot of the system.

Field	Description
Firewall	<p>Default = &lt;None&gt; (No firewall)</p> <p>Allows the selection of a system firewall to be applied to traffic routed from LAN2 to LAN1.</p>

**Related links**

[System](#) on page 203

## DNS

Navigation: **System | DNS**

DNS is a mechanism through which the URL's requested by users, such as www.avaya.com, are resolved into IP addresses. These requests are sent to a Domain Name Server (DNS) server, which converts the URL to an IP address. Typically the internet service provider (ISP) will specify the address of the DNS server their customers should use.

WINS (Windows Internet Name Service) is a similar mechanism used within a Windows network to convert PC and server names to IP addresses via a WINS server.

If the system is acting as a DHCP server, in addition to providing clients with their own IP address settings it can also provide them with their DNS and WINS settings if requested by the client.

These settings are not mergeable. Changes to these settings require a reboot of the system.

**Related links**

[System](#) on page 203

## Voicemail

Navigation: **System | Voicemail**

**Additional configuration information**

For information on configuring Voicemail Pro resiliency, see [Server Edition Resiliency](#) on page 746.

**Configuration settings**

The following settings are used to set the system's voicemail server type and location. Fields are enabled or grayed out as appropriate to the selected voicemail type. Refer to the appropriate voicemail installation manual for full details.

These settings are mergeable with the exception of **Voicemail Type** and **Voicemail IP Address**. Changes to these settings requires a reboot of the system.

Field	Description
<b>Voicemail Type</b>	<p>Defaults: Non-Server Edition = Embedded Voicemail, Primary Server = Voicemail Pro, Server Edition Secondary Server with independent voicemail or for Outbound Contact Express = Voicemail Pro, Server Edition Others: Centralized Voicemail.</p> <p>Sets the type of voicemail system being used. The options are:</p> <ul style="list-style-type: none"> <li>• <b>None:</b> No voicemail operation.</li> <li>• <b>Analog Trunk MWI:</b> Select this option to support receiving a message waiting indicator (MWI) signal from analog trunks terminating on the ATM4U-V2 card. MWI is a telephone feature that turns on a visual indicator on a telephone when there are recorded messages.</li> <li>• <b>Avaya Aura Messaging:</b> Select this option if you want to configure the system to use Avaya Aura Messaging as the central voicemail system. If you choose this option, you are still able to use Embedded Voicemail or Voicemail Pro at each branch to provide auto-attendant operation and announcements for waiting calls. When selected, access to voicemail is routed via an SM line to the numbers specified in the <b>AAM Number</b> field. The optional <b>AAM PSTN Number</b> can be configured for use when the SM Line is not in service.</li> </ul> <p>For a setup where the voicemail box numbers configured on Avaya Aura Messaging or Modular Messaging are same as the caller's DID, the short code to route the PSTN call should be such that the caller-id is withheld ( "W" in the telephone-number of the shortcode ). This is to make sure that, during rainy day - the voicemail system does not automatically go to the voicemail box of the caller based on the caller id.</p> <ul style="list-style-type: none"> <li>• <b>Call Pilot:</b> Select this option if you want to configure the system to use CallPilot over SIP as the central voicemail system. If you choose this option, you are still able to use <b>Embedded Voicemail</b> or Voicemail Pro at each branch to provide auto-attendant operation and announcements for waiting calls. When selected, access to voicemail is routed via SM line to the numbers specified in the <b>CallPilot Number</b> field.</li> </ul> <p><b>* Note:</b></p> <p>The <b>CallPilot PSTN Number</b> field and associated <b>Enable Voicemail Instructions Using DTMF</b> check box are not supported. IP Office cannot access the CallPilot system over the PSTN when the Session Manager line is down.</p> <p><b>* Note:</b></p> <p>Users can access their CallPilot voicemail by dialing the Voicemail Collect short code. Access to CallPilot voicemail from Auto Attendant cannot be enabled by setting a Normal Transfer action to point to the Voicemail Collect short code. If desired, it can be enabled by setting a Normal Transfer action to point to the CallPilot number.</p> <ul style="list-style-type: none"> <li>• <b>Centralized Voicemail</b> Select this option when using a Voicemail Pro system installed and licensed on another system in a multi-site network. The outgoing line group of the H.323 IP line connection to the system with the Voicemail Pro should be entered as the <b>Voicemail Destination</b>. In a Server Edition network this option is</li> </ul>

*Table continues...*

Field	Description
	<p>used on the Secondary Server and expansion systems to indicate that they use the Primary Server for as their voicemail server.</p> <ul style="list-style-type: none"> <li>• <b>Distributed Voicemail:</b> This option can be used when additional Voicemail Pro voicemail servers are installed in a multi-site network and configured to exchange messages with the central voicemail server using email. This option is used if this system should use one of the additional servers for its voicemail services rather than the central sever. When selected, the <b>Voicemail Destination</b> field is used for the outgoing H.323 IP line to the central system and the <b>Voicemail IP Address</b> is used for the IP address of the distributed voicemail server the system should use. This option is not supported by Server Edition systems.</li> <li>• <b>Embedded Voicemail</b> On systems with an Avaya memory card, select this option to run Embedded Voicemail which stores messages and prompts on the memory card. It also supports internal Auto Attendant configuration through the system configuration. The IP500 V2 supports 2 simultaneous Embedded Voicemail calls by default but can be licensed for up to 6. The licensed limit applies to total number of callers leaving messages, collecting messages and or using an auto attendant. This option is not supported by Server Edition systems.</li> <li>• <b>Group Voicemail</b> This option is used to support third-party voicemail systems attached by extension ports in the group specified as the <b>Voicemail Destination</b>. This option is not supported by Server Edition systems.</li> <li>• <b>Modular Messaging over SIP</b> Select this option if you want to configure the system to use Modular Messaging over SIP as the central voicemail system. If you choose this option, you are still able to use Embedded Voicemail or Voicemail Pro at each branch to provide auto-attendant operation and announcements for waiting calls. When selected, access to voicemail is routed via an SM line to the numbers specified in the <b>MM Number</b> field. The optional <b>MM PSTN Number</b> can be configured for use when the SM Line is not in service.</li> </ul> <p><b>* Note:</b></p> <p>Embedded Voicemail and Voicemail Pro are available only in Distributed branch deployments. They are not available when there are centralized users configured for a IP Office system that is deployed as either a Centralized branch or a mixed branch.</p> <p>The Embedded Voicemail option uses the Essential Edition and the Additional Voicemail Ports licenses to control the number of ports that can be used. These licenses are also used to control the number of ports on systems where Embedded Voicemail is configured to provide local Auto Attendant and announcements while the selected option for voicemail is one of the central voicemail options through the Session Manager (i.e. Avaya Aura Messaging, Modular Messaging, or CallPilot).</p> <p>Similarly, the Voicemail Pro option uses the Preferred Edition and the Incremental Voicemail Ports licenses to control the number of ports that can be used. These licenses are also used to control the number of ports on systems where Voicemail</p>

*Table continues...*

Field	Description
	<p>Pro is configured to provide local Call Flow processing while the selected option for voicemail is Avaya Aura Messaging, Modular Messaging or CallPilot.</p> <ul style="list-style-type: none"> <li>- When the system routes a call to the voicemail server it indicates the locale for which matching prompts should be provided if available. The locale sent to the voicemail server by the system is determined as show below. If the required set of prompts is not available, the voicemail will fallback to another appropriate language and finally to English (refer to the appropriate voicemail installation manual for details).</li> <li>- <b>Short Code Locale:</b> The short code locale, if set, is used if the call is routed to voicemail using the short code.</li> <li>- <b>Incoming Call Route Locale:</b> The incoming call route locale, if set, is used if caller is external.</li> <li>- <b>User Locale:</b> The user locale, if set, is used if the caller is internal.</li> <li>- <b>System Locale:</b> If no user or incoming call route locale is set, the system locale is used unless overridden by a short code locale.</li> <li>- Systems using Embedded Voicemail, if the required set of upgraded language prompts to match the locale is not present on the system SD card, Manager will display an error. The required prompt set can be uploaded from Manager using the Add/Display VM Locales option.</li> <li>• <b>Remote Audix Voicemail:</b> Select this option if using a remote Avaya Intuity Audix or MultiMessage voicemail system. Requires entry of an <b>Audix Voicemail</b> license in Licenses. This option is not supported by Server Edition systems.</li> <li>• <b>Voicemail Pro</b> Select this option when using Voicemail Pro. The IP address of the PC being used should be set as the <b>Voicemail IP Address</b>. In a Server Edition network this option is used on the Primary Server. It can also be used on the Secondary Server if the Secondary server is connected to its own voice mail server or if the Secondary Server is part of an Outbound Contact Express deployment. Use of Voicemail Pro requires licenses for the number of simultaneous calls to be supported. Licenses are not required for an Outbound Contact Express deployment.</li> </ul>
<b>Voicemail Mode</b>	<p>Default = IP Office Mode. Embedded Voicemail on IP500 V2 systems can use either <b>IP Office Mode</b> or <b>Intuity Mode</b> key presses for mailbox functions. End users should be provided with the appropriate mailbox user guide for the mode selected. You can switch between modes without losing user data, such as passwords, greetings, or messages.</p> <p>The following user guides are available from the Avaya support web site:</p> <ul style="list-style-type: none"> <li>• IP Office Essential Edition - Embedded Voicemail User Guide (Intuity Mode)</li> <li>• IP Office Essential Edition - Embedded Voicemail User Guide (IP Office Mode)</li> <li>• IP Office Voicemail Pro Mailbox User Guide (Intuity Mode)</li> <li>• IP Office Voicemail Pro Mailbox User Guide (IP Office Mode)</li> </ul>

*Table continues...*

Field	Description
<b>Voicemail Destination</b>	<p>Defaults: Non-Server Edition = Blank, Server Edition = IP trunk connection to the Primary Server.</p> <ul style="list-style-type: none"> <li>• When the <b>Voicemail Type</b> is set to <b>Remote Audix Voicemail, Centralized Voicemail</b> or <b>Distributed Voicemail</b>, this setting is used to enter the outgoing line group of the line configured for connection to the phone system hosting the central voicemail server.</li> <li>• When the <b>Voicemail Type</b> is set to <b>Group Voicemail</b>, this setting is used to specify the group whose user extensions are connected to the 3rd party voicemail system.</li> <li>• When the <b>Voicemail Type</b> is set to <b>Analogue Trunk MWI</b>, this setting is used to specify the phone number of the message center. All analogue trunks configured for <b>Analogue Trunk MWI</b> must have the same destination.</li> </ul>
<b>Voicemail IP Address</b>	<p>Defaults: Non-Server Edition = 255.255.255.255, Primary Server = Primary Server IP Address.</p> <p>This setting is used when the <b>Voicemail Type</b> is set to <b>Voicemail Pro</b> or <b>Distributed Voicemail</b>. It is the IP address of the PC running the voicemail server that the system should use for its voicemail services. If set as 255.255.255.255, the control unit broadcasts on the LAN for a response from a voicemail server. If set to a specific IP address, the system connects only to the voicemail server running at that address. If the system is fitted with an Unified Communication Module hosting Voicemail Pro, the field should be set to 169.254.0.2.</p>
<b>Backup Voicemail IP Address</b>	<p>Defaults: Primary Server = Secondary Server IP Address, All others = 0.0.0.0 (Off).</p> <p>This option is supported with Voicemail Pro.</p> <p>An additional voicemail server can be setup but left unused. If contact to the voicemail server specified by the <b>Voicemail IP Address</b> is lost, responsibility for voicemail services is temporarily transferred to this backup server address.</p>
<b>Maximum Record Time</b>	<p>Default = 120 seconds. Range = 30 to 180 seconds. This field is only available when <b>Embedded Voicemail</b> is selected as the <b>Voicemail Type</b>. The value sets the maximum record time for messages and prompts.</p>
<b>Messages Button Goes to Visual Voice</b>	<p>Default = On.</p> <p>Visual Voice allows phone users to check their voicemail mailboxes and perform action such as play, delete and forward messages through menus displayed on their phone. By default, on phones with a <b>MESSAGES</b> button, the navigation is via spoken prompts. This option allows that to be replaced by Visual Voice on phones that support Visual Voice menus. For further details see the button action.</p>
<b>Enable Outcalling</b>	<p>Default = Off (<i>Outcalling not allowed</i>).</p> <p>This setting is used to enable or disable system support for outcalling on <b>Embedded Voicemail</b> and Voicemail Pro. When not selected, all outcalling and configuration of outcalling through mailboxes is disabled. For Voicemail Pro, outcalling can also be disabled at the individual user mailbox level using the Voicemail Pro client.</p>

Table continues...

Field	Description
<b>DTMF Breakout</b>	<p>Allows system defaults to be set. These are then applied to all user mailboxes unless the users own settings differ.</p> <p>The Park &amp; Page feature is supported when the system voicemail type is configured as <b>Embedded Voicemail</b> or <b>Voicemail Pro</b>. Park &amp; Page is also supported on systems where Avaya Aura Messaging, Modular Messaging over SIP, or CallPilot (for IP Office Aura Edition with CS 1000 deployments) is configured as the central voice mail system and the local Embedded Voicemail or Voicemail Pro provides auto attendant operation. The Park &amp; Page feature allows a call to be parked while a page is made to a hunt group or extension. This feature can be configured for Breakout DTMF 0, Breakout DTMF 2, or Breakout DTMF 3.</p>
<b>Reception/Breakout (DTMF 0)</b>	<p>The number to which a caller is transferred if they press 0 while listening to the mailbox greeting rather than leaving a message (*0 on Embedded Voicemail in IP Office Mode).</p> <p>For voicemail systems set to Intuity emulation mode, the mailbox owner can also access this option when collecting their messages by dialing *0.</p> <p>If the mailbox has been reached through a Voicemail Pro call flow containing a <b>Leave Mail</b> action, the option provided when 0 is pressed are:</p> <ul style="list-style-type: none"> <li>• For IP Office mode, the call follows the <b>Leave Mail</b> action's <b>Failure</b> or <b>Success</b> results connections depending on whether the caller pressed 0 before or after the record tone.</li> <li>• For Intuity mode, pressing 0 always follows the <b>Reception/Breakout (DTMF 0)</b> setting.</li> <li>• When Park &amp; Page is selected for a DTFM breakout, the following drop-down boxes appear: <ul style="list-style-type: none"> <li>- <b>Paging Number:</b> Displays a list of hunt groups and users (extensions). Select a hunt group or extension to configure this option.</li> <li>- <b>Retries:</b> The range is 0 to 5. The default setting is 0.</li> <li>- <b>Retry Timeout</b> Provided in the format M:SS (minute:seconds). The range can be set in 15-second increments. The minimum setting is 15 seconds and the maximum setting is 5 minutes. The default setting is 15 seconds</li> </ul> </li> </ul>
<b>Breakout (DTMF 2)</b>	<p>The number to which a caller is transferred if they press 2 while listening to the mailbox greeting rather than leaving a message (*2 on Embedded Voicemail in IP Office Mode).</p>
<b>Breakout (DTMF 3)</b>	<p>The number to which a caller is transferred if they press 3 while listening to the mailbox greeting rather than leaving a message (*3 on Embedded Voicemail in IP Office Mode).</p>
<b>Voicemail Code Complexity</b> <p>Defines the requirements for the voicemail code.</p> <p>For IP Office systems that have <b>Voicemail Type</b> set to <b>Centralized</b>, the <b>Voicemail Code Complexity</b> settings must be the same as the IP Office system that is connected to Voicemail Pro.</p>	

*Table continues...*

Field	Description
<b>Enforcement</b>	Default = On.  When on, a user PIN is required. The enforcement is not forced during upgrade but after checking, it can not be cleared.
<b>Minimum Length</b>	Default = 6. Maximum 31 digits. Older configurations can continue to have 4 digits with a maximum of 20 digits.
<b>Complexity</b>	Default = On.  When on, the following complexity rules are enforced. <ul style="list-style-type: none"> <li>• The user extension number cannot be used.</li> <li>• A PIN consisting of repeated digits is not allowed (111111).</li> <li>• A PIN consisting of a sequence, forward or reverse, is not allowed (123456, 564321).</li> </ul> <p>The number of users having invalid Voicemail Code complexity is highlighted below this field in red colored text.</p>
<b>SIP Settings</b>	For Enterprise Branch deployments, these settings are used for calls made or received on a SIP line where any of the line's SIP URI fields are set to use internal data. For Embedded Voicemail and Voicemail Pro, for calls made or received on a SIP line where any of the line's SIP URI fields are set to <b>Use Internal Data</b> , that data is taken from these settings. These options are shown if the system has SIP trunks and is set to use <b>Embedded Voicemail, Voicemail Lite/Pro, Centralized Voicemail</b> or <b>Distributed Voicemail</b> .
<b>SIP Name</b>	Default = Blank on Voicemail tab/Extension number on other tabs.  The value from this field is used when the From field of the SIP URI being used for a SIP call is set to <b>Use Internal Data</b> .
<b>SIP Display Name (Alias)</b>	Default = Blank on Voicemail tab/Name on other tabs.  The value from this field is used when the Display Name field of the SIP URI being used for a SIP call is set to <b>Use Internal Data</b>
<b>Contact</b>	Default = Blank on Voicemail tab/Extension number on other tabs. The value from this field is used when the Contact field of the SIP URI being used for a SIP call is set to <b>Use Internal Data</b> .
<b>Anonymous</b>	Default = ON on Voicemail tab or OFF on other tabs. If the Local URI and Contact fields in the SIP URI are set to <b>Use Internal Data</b> , selecting this option inserts <b>Anonymous</b> into those fields rather than the SIP Name set above.

### Voicemail Language Prompts

When the system routes a call to the voicemail server it indicates the locale for which matching prompts should be provided if available. The locale sent to the voicemail server by the system is determined as show below. If the required set of prompts is not available, the voicemail will fallback to another appropriate language and finally to English (refer to the appropriate voicemail installation manual for details).

- **Short Code Locale:** The short code locale, if set, is used if the call is routed to voicemail using the short code.



- **Incoming Call Route Locale:** The incoming call route locale, if set, is used if caller is external.
- **User Locale:** The user locale, if set, is used if the caller is internal.
- **System Locale:** If no user or incoming call route locale is set, the system locale is used unless overridden by a short code locale.

Systems using Embedded Voicemail, if the required set of upgraded language prompts to match the locale is not present on the system SD card, Manager will display an error. The required prompt set can be uploaded from Manager using the Add/Display VM Locales option.

#### Related links

[System](#) on page 203

---

## Telephony

Used to set the default telephony operation of the system. Some settings shown here can be overridden for individual users through their User | Telephony tab. The settings are split into a number of sub-tabs.

#### Related links

[System](#) on page 203

[Telephony](#) on page 233

[Park and Page](#) on page 240

[Tones and Music](#) on page 241

[Ring Tones](#) on page 245

[SM](#) on page 246

[Call Log](#) on page 248

[TUI](#) on page 249

## Telephony

Navigation: **System | Telephony**

### Additional configuration information

- The Directory Overrides Barring setting allows you to control barred numbers. For additional configuration information, see [Call Barring](#) on page 659.
- The **Inhibit Off-Switch Forward/Transfer** stops any user from transferring or forwarding calls externally. For additional information, see [Off-Switch Transfer Restrictions](#) on page 731.
- For additional information regarding the **Media Connection Preservation** setting, see [Media Connection Preservation](#) on page 640.
- For additional information on ring tones, see [Ring Tones](#) on page 619.

### Configuration Settings

Used to configure a wide range of general purpose telephony settings for the whole system.

These settings are mergeable with the exception of **Companding LAW** and **Media Connection Preservation**. Changes to these settings requires a reboot of the system.

Field	Description
<b>Analog Extensions</b>	
These settings apply only to analog extension ports provided by the system. For Server Edition this field is only available on Expansion System (V2) systems	
<b>Default Outside Call Sequence</b>	<p>Default = Normal</p> <p>This setting is only used with analog extensions. It sets the ringing pattern used for incoming external calls. For details of the ring types see <b>System   Telephony   Ring Tones</b>.</p> <p>This setting can be overridden by a user's <b>User   Telephony   Call Settings</b> setting. Note that changing the pattern may cause fax and modem device extensions to not recognize and answer calls.</p>
<b>Default Inside Call Sequence</b>	<p>Default = Ring Type 1</p> <p>This setting is only used with analog extensions. It sets the ringing pattern used for incoming internal calls. For details of the ring types see <b>System   Telephony   Ring Tones</b>. This setting can be overridden by a user's <b>User   Telephony   Call Settings</b> setting.</p>
<b>Default Ring Back Sequence</b>	<p>Default = Ring Type 2</p> <p>This setting is only used with analog extensions. It sets the ringing pattern used for ringback calls such as hold return, park return, voicemail ringback, and Ring Back when Free. For details of the ring types see <b>System   Telephony   Ring Tones</b>.</p> <p>This setting can be overridden by a user's <b>User   Telephony   Call Settings</b> setting.</p>
<b>Restrict Analog Extension Ringer Voltage</b>	<p>Default = Off.</p> <p>Supported on IP500 V2 systems only. If selected, the ring voltage on analogue extension ports on the system is limited to a maximum of 40V Peak-Peak. Also when selected, the message waiting indication (MWI) settings for analog extension are limited to <b>Line Reversal A</b>, <b>Line Reversal B</b> or <b>None</b>. Any analog extension already set to another MWI setting is forced to <b>Line Reversal A</b>.</p>
<b>Dial Delay Time (secs)</b>	<p>Default = 4 (USA/Japan) or 1 (ROW). Range = 1 to 30 seconds.</p> <p>This setting sets the time the system waits following a dialed digit before it starts looking for a short code match. In situations where there are potential short codes matches but not exact match, it also sets the delay following the dialing of a digit before dialing complete is assumed.</p>
<b>Dial Delay Count</b>	<p>Default = 0 digits (USA/Japan) or 4 digits (ROW). Range = 0 to 30 digits.</p> <p>This setting sets the number of digits dialed after which the system starts looking for a short code match regardless of the <b>Dial Delay Time</b>.</p>

*Table continues...*

Field	Description
<b>Default No Answer Time (secs)</b>	<p>Default = 15 seconds. Range = 6 to 99999 seconds.</p> <p>This setting controls the amount of time before an alerting call is considered as unanswered. How the call is treated when this time expires depends on the call type.</p> <p>For calls to a user, the call follows the user's Forward on No Answer settings if enabled. If no forward is set, the call will go to voicemail if available or else continues to ring. This timer is also used to control the duration of call forwarding if the forward destination does not answer. It also controls the duration of ringback call alerting. This setting is overridden by the <b>User   Telephony   Call Settings   No Answer Time</b> setting for a particular user if different.</p> <p>For calls to hunt groups, this setting controls the time before the call is presented to the next available hunt group member. This setting is overridden by the <b>Hunt Group   Hunt Group   No Answer Time</b> setting for a particular hunt group if different.</p>
<b>Hold Timeout (secs)</b>	<p>Default = Locale specific. Range = 0 (Off) to 99999 seconds.</p> <p>This setting controls how long calls remain on hold before recalling to the user who held the call. Note that the recall only occurs if the user has no other connected call. Recalled calls will continue ringing and do not follow forwards or go to voicemail.</p>
<b>Park Timeout (secs)</b>	<p>Default = Locale specific. Range 0 (Off) to 99999 seconds.</p> <p>This setting controls how long calls remain parked before recalling to the user who parked the call. Note that the recall only occurs if the user has no other connected call. Recalled calls will continue ringing and do not follow forwards or go to voicemail.</p>
<b>Ring Delay</b>	<p>Default = 5 seconds. Range = 0 to 98 seconds. This setting is used when any of the user's programmed appearance buttons is set to Delayed ringing. Calls received on that button will initially only alert visually. Audible alerting will only occur after the ring delay has expired. This setting can be overridden by a ring delay set for an individual user (<b>User   Telephony   Multi-line Options   Ring Delay</b>).</p>

*Table continues...*

Field	Description
<b>Call Priority Promotion Time (secs)</b>	<p>Default = Disabled. Range = Disabled, 10 to 999 seconds.</p> <p>When calls are queued for a hunt group, higher priority calls are placed ahead of lower priority calls, with calls of the same priority sort by time in queue. External calls are assigned a priority (<b>1-Low, 2-Medium or 3-High</b>) by the Incoming Call Route that routed the call. Internal calls are assigned a priority of <b>1-Low</b>. This option can be used to increase the priority of a call each time it has remained queued for longer than this value. The calls priority is increased by 1 each time until it reaches 3-High.</p> <p>In situations where calls are queued, high priority calls are placed before calls of a lower priority. This has a number of effects:</p> <ul style="list-style-type: none"> <li>• Mixing calls of different priority is not recommended for destinations where Voicemail Pro is being used to provided queue ETA and queue position messages to callers since those values will no longer be accurate when a higher priority call is placed into the queue. Note also that Voicemail Pro will not allow a value already announced to an existing caller to increase.</li> <li>• If the addition of a higher priority call causes the queue length to exceed the hunt group's Queue Length Limit, the limit is temporarily raised by 1. This means that calls already queued are not rerouted by the addition of a higher priority call into the queue.</li> </ul>
<b>Default Currency</b>	<p>Default = Locale specific.</p> <p>This setting is used with ISDN Advice of Charge (AOC) services. Note that changing the currency clears all call costs stored by the system except those already logged through SMDR. The currency is displayed in the system SMDR output.</p>
<b>Default Name Priority</b>	<p>Default = Favor Trunk.</p> <p>For SIP trunks, the caller name displayed on an extension can either be that supplied by the trunk or one obtained by checking for a number match in the extension user's personal directory and the system directory. This setting determines which method is used by default. For each SIP line, this setting can be overridden by the line's own <b>Name Priority</b> setting if required. Select one of the following options:</p> <ul style="list-style-type: none"> <li>• <b>Favor Trunk:</b> Display the name provided by the trunk. For example, the trunk may be configured to provide the calling number or the name of the caller. The system should display the caller information as it is provided by the trunk. If the trunk does not provide a name, the system uses the <b>Favor Directory</b> method.</li> <li>• <b>Favor Directory:</b> Search for a number match in the extension user's personal directory and then in the system directory. The first match is used and overrides the name provided by the SIP line. If no match is found, the name provided by the line, if any, is used.</li> </ul>
<b>Media Connection Preservation</b>	<p>Default = Enabled.</p> <p>When enabled, attempts to maintain established calls despite brief network failures. Call handling features are no longer available when a call is in a preserved state. When enabled, Media Connection Preservation applies to SCN links and Avaya H.323 phones that support connection preservation.</p>

*Table continues...*

Field	Description
<b>Phone Failback</b>	<p>Default = Automatic.</p> <p>Applies to H.323 phones that support resiliency. The options are:</p> <ul style="list-style-type: none"> <li>• <b>Automatic</b></li> <li>• <b>Manual</b></li> </ul> <p>Phones are permitted to failover to the secondary gatekeeper when the IP Office Line link to the primary gatekeeper is down.</p> <p>When set to <b>Automatic</b>, if a phone's primary gatekeeper has been up for more than 10 minutes, the system causes the phone to failback if the phone is not in use. If the phone is in use, the system will reattempt failback 10 seconds after the phone ceases to be in use.</p> <p>When set to <b>Manual</b>, phones remain in failover until manually restarted or re-registered, after which the phone attempts to fail back.</p> <p> <b>Note:</b> Manual failback is not supported on SIP phones.</p>
<b>Login Code Complexity</b>	
Defines the requirements for the login code.	
<b>Enforcement</b>	<p>Default = On.</p> <p>When on, a user PIN is required.</p>
<b>Minimum Length</b>	<p>Default = 6. Maximum 15 digits.</p> <p>The number of users with login codes less than six digits is displayed below the field in red colored text.</p>
<b>Complexity</b>	<p>Default = On.</p> <p>When on, the following complexity rules are enforced.</p> <ul style="list-style-type: none"> <li>• The user extension number cannot be used.</li> <li>• A PIN consisting of repeated digits is not allowed (111111).</li> <li>• A PIN consisting of forward or backward sequence are not allowed. Examples: 123456, 654321.</li> </ul> <p>The number of users with invalid Code Complexity is highlighted below the field in red colored text.</p>
<b>Send RTCP to an RTCP Collector</b>	When the check box is selected, system RTCP reporting is enabled. For IP Office Release 10.0 and higher, in addition to having the individual phones send RTCP call quality reports, the system can also send RTCP reports for calls.
<b>Server Address</b>	This Sets the address of the third-party QoS monitoring application to which the system sends RTCP reports.
<b>UDP Port Number</b>	The destination port. The default for this field is 5005.

*Table continues...*

Field	Description
<b>RTCP reporting interval (secs)</b>	This setting sets the time interval at which the system sends RTCP reports.
<b>Companding Law</b>	<p>These settings should not normally be changed from their defaults. They should only be used where 4400 Series phones (ULAW) are installed on systems which have A-Law digital trunks.</p> <p><b>A-Law or U-Law</b>&gt; PCM (Pulse Code Modulation) is a method for encoding voice as data. In telephony, two methods of PCM encoding are widely used, A-Law and U-Law (also called Mu-Law or <math>\mu</math>-Law). Typically U-Law is used in North America and a few other locations while A-Law is used elsewhere. As well as setting the correct PCM encoding for the region, the A-Law or U-Law setting of a system when it is first started affects a wide range of regional defaults relating to line settings and other values.</p> <p>For IP500 V2 systems, the encoding default is set by the type of Feature Key installed when the system is first started. The cards are either specifically A-Law or U-Law.</p>
<b>DSS Status</b>	<p>Default = Off</p> <p>This setting affects Avaya display phones with programmable buttons. It controls whether pressing a DSS key set to another user who has a call ringing will display details of the caller. When off, no caller information is displayed.</p>
<b>Auto Hold</b>	<p>Default = On (Off for the United States locale).</p> <p>Used for users with multiple appearance buttons. When on, if a user presses another appearance button during a call, their current call is placed on hold. When off, if a users presses another appearance button during a call, their current call is disconnected.</p>
<b>Show Account Code</b>	<p>Default = On This setting controls the display and listing of system account codes.</p> <ul style="list-style-type: none"> <li>• <b>When on:</b> When entering account codes through a phone, the account code digits are shown while being dialed.</li> <li>• <b>When off:</b> When entering account codes through a phone, the account code digits are replaced by s characters on the display.</li> </ul>
<b>Inhibit Off-Switch Forward/Transfer</b>	<p>Default = On</p> <p>When enabled, this setting stops any user from transferring or forwarding calls externally.</p>
<b>Restrict Network Interconnect</b>	<p>Default = Off.</p> <p>When this option is enabled, each trunk is provided with a <b>Network Type</b> option that can be configured as either <b>Public</b> or <b>Private</b>. The system will not allow calls on a public trunk to be connected to a private trunk and vice versa, returning number unobtainable indication instead.</p> <p>Due to the nature of this feature, its use is not recommended on systems also using any of the following other system features: multi-site networks, VPNremote, application telecommuter mode.</p>

*Table continues...*

Field	Description
<b>Include location specific information</b>	<p>Default = Off.</p> <p>When set to On, this setting is available in the trunk configuration settings when <b>Network Type</b> is set to <b>Private</b>.</p> <p>Set to <b>On</b> if the PBX on the other end of the trunk is toll compliant.</p>
<b>Drop External Only Impromptu Conference</b>	<p>Default = On.</p> <p>If selected, when the last remaining internal user in a conference exits the conference, the conference is ended, regardless of whether it contains any external callers.</p> <p>If not selected, the conference is automatically ended when the last internal party or trunk that supports reliable disconnect exits the conference. The Inhibit Off-Switch Forward/Transfer option above is no longer applied to conference calls.</p>
<b>Visually Differentiate External Call</b>	<p>Default = Off.</p> <p>This setting is applied to the lamp flashing rate used for bridged appearance and call coverage appearance buttons on 1400, 1600 and 9600 Series phones and on their button modules. When selected, external calls alerting on those buttons will use a slow flash (200ms on/50ms off). If not selected or if the call is internal, normal flashing (500ms on/500ms off) is used.</p>
<b>Unsupervised Analog Trunk Disconnect Handling</b>	<p>Default = Off.</p> <p>When using analog trunks, various methods are used for trunk supervision, ie. to detect when the far end of the trunk has disconnected and so disconnect the local end of the call. Depending on the locale, the system uses Disconnect Clear signalling and or Busy Tone Detection. This setting should only be enabled if it is know that the analog trunks do not provide disconnect clear signalling or reliable busy tone. For Server Edition this field is only available on Expansion System (V2) systems. When enabled:</p> <ul style="list-style-type: none"> <li>• Disconnect Clear signalling detection is disabled. Busy tone detection remains on.</li> <li>• Unsupervised transfers and trunk-to-trunk transfers of analog trunk calls are not allowed. The <b>Allow Analog Trunk to Trunk Connect</b> setting on analog trunks (Line   Analog Options) is disabled.</li> <li>• If Voicemail Pro is being used for external call transfers, <b>Supervised Transfer</b> actions should be used in call flows rather than <b>Transfer</b> actions.</li> <li>• All systems in the network must have this setting set to match each other.</li> </ul>
<b>High Quality Conferencing</b>	<p>Default = On.</p> <p>Supports the use of the G.722 codec. IP lines and extensions using G.722 are provided with wide band audio. If <b>High Quality Conferencing</b> is enabled, when several wide band audio devices are in the same conference, the system will ensure that the audio between them remains wide band, even if the conference also contains other lines and devices using narrow band audio (analog devices, digital devices and IP devices using codecs other than G.722).</p>

*Table continues...*

Field	Description
<b>Digital/Analogue Auto Create User</b>	<p>Default = On. (IP500 V2 only. Default = Off for Server Edition/On for others)</p> <p>When enabled, an associated user is created for each digital/analogue extension created. Digital/analogue extension creation occurs on initial start up, reset of configuration, or addition of new digital/analogue expansion units or plug-in modules.</p>
<b>Directory Overrides Barring</b>	<p>Default = On.</p> <p>When enabled, barred numbers are not barred if the dialed number is in the External Directory.</p>
<b>Advertize Callee State To Internal Callers</b>	<p>Default = Off.</p> <p>When enabled, for internal calls, additional status information is communicated to the calling party.</p> <p>Not supported for SIP endpoints except for J100 Series phones (not including the J129).</p> <ul style="list-style-type: none"> <li>• When calling another internal phone and the called phone is set to Do Not Disturb or on another call, the calling phone displays “Do Not Disturb” or “On Another Call” rather than “Number Busy”.</li> <li>• On 9500 Series, 9600 Series and J100 Series, if a line appearance is programmed on a button on phone A and that line is in use on phone B, then phone A displays the name of the current user of the line along with the line number.</li> <li>• If a line appearance on a phone is in use elsewhere in the system and another extension unsuccessfully attempts to seize that line, the phone displays “In Use:&lt;name&gt;” where &lt;name&gt; is the name of the user currently using the line.</li> </ul> <p>This configuration parameter sets the system wide default. Individual users can be configured for this feature using the setting <b>User   Telephony   Call Settings   Advertize Callee State To Internal Callers</b></p>
<b>Internal Ring on Transfer</b>	<p>Default = Off.</p> <p>When enabled, the transfer enquiry calls ring with internal ring tone even if the call that is being transferred is an external call. If the user transferring the call completes the call when the call is ringing, the ring tone played to the target changes to the ring tone appropriate for the call being transferred.</p> <p>This feature is supported on phone series: 1400, 9500, 1600, 9600, and analog phones.</p> <p>This feature is not supported on SIP and H.323 DECT phones.</p>

**Related links**

[Telephony](#) on page 233

**Park and Page**

Navigation: **System | Telephony | Park and Page**

The Park and Page tab allows for simple configuration of the of the short code and the programmable button for the park and page function.



These settings are mergeable. Changes to these settings do not require a reboot of the system.

Field	Description
<b>Central Park Range</b>	<p>Default = Blank. Range = nX to nnnnnnnXX The park slot ID range definition, where n is a digit sequence from 1 to 9999999 and X represents a park slot value from 0 to 99. The Central Park Range cannot exceed 9 characters total length.</p> <p>Examples:</p> <ul style="list-style-type: none"> <li>• 1X defines range 10-19</li> <li>• 3XX defines range 300-399</li> <li>• 9876543XX defines range 987654300-987654399</li> </ul>
<b>Page Target Group List</b>	<p>Default = Blank. The list of paging group targets that are presented on supported phones if the Page action is requested after the Call Park.</p> <p>On some phones, only the first three groups can be presented as Page options (via the Softkeys on the phone). On phones that support scrolling lists, a larger list of possible Page targets can be presented.</p>

#### Related links

[Telephony](#) on page 233

## Tones and Music

Navigation: **System | Telephony | Tones and Music**

### Additional configuration information

For additional information on configuring hold music, see [Music On Hold](#) on page 620.

### Configuration settings

Used to configure the various tones and music on hold sources used by the system.

The settings are mergeable with the exception of **Disconnect Tone** and **Busy Tone Detection**. Changes to these settings requires a reboot of the system.

Deleting any of the hold music **Alternate Sources** requires a reboot.

Field	Description
<b>Conferencing Tone</b>	<p>Default = Entry &amp; Exit Tones.</p> <p>This settings controls how conference tones are used. The options are:</p> <ul style="list-style-type: none"> <li>• <b>Entry &amp; Exit Tones:</b> A single tone is heard when a new party joins a conference and double-tone is heard when a party leaves the conference.</li> <li>• <b>Repeating Tone:</b> A conference tone is heard every 10 seconds by all conference parties.</li> </ul> <p>Note that no conference tones are played in a conference initiated by an Outbound Contact Express agent.</p>

*Table continues...*

Field	Description
<b>Disconnect Tone</b>	<p>Default = Default (Use locale setting).</p> <p>For digital and IP phones, when the system detects that the far end of a call has disconnected, it can make the near end either go idle or play disconnect tone. By default, the chosen behavior depends on the system locale. This field can be used to override the locale's default action and force either disconnect tone or go idle. The options are:</p> <ul style="list-style-type: none"> <li>• <b>Default:</b> Use the system locale specific action for disconnected calls.</li> <li>• <b>On:</b> Play disconnect tone when far end disconnection is detected.</li> <li>• <b>Off:</b> Go idle when far end disconnection is detected.</li> </ul>
<b>Busy Tone Detection</b>	<p>Default = Off. Enables or disables the use of busy tone detection for call clearing. This is a system wide setting.</p>
<b>CLI Type</b>	<p>This field is used to set the CLI detection used for incoming analogue trunks. Note that the CLI Type field is shown for locales other than <b>Customize</b>. For the <b>Customize</b> locale, it is set through the <b>System   System</b> form. The options are:</p> <ul style="list-style-type: none"> <li>• <b>DTMF</b></li> <li>• <b>FSK V23</b></li> <li>• <b>FSK BELL202</b></li> </ul>
<b>Local Dial Tone</b>	<p>Default = On</p> <p>For all normal operation this setting should be left enabled as it allows the system to provide dial tone to users (essential for MSN working).</p>
<b>Local Busy Tone</b>	<p>Default = Off</p> <p>This setting should only be used when the local exchange gives a busy signal via Q.931 but does not provide busy tone.</p>
<b>Beep on Listen</b>	<p>Default = On</p> <p>This setting controls whether call parties hear a repeating tone when their call is monitored by another party using the Call Listen feature.</p> <p> <b>Warning:</b></p> <p>The use of features to listen to a call without the other call parties being aware of that monitoring may be subject to local laws and regulations. Before enabling the feature you must ensure that you have complied with all applicable local laws and regulations. Failure to do so may result in severe penalties.</p>
<b>GSM Silence Suppression</b>	<p>Default = Off.</p> <p>This setting should only be selected if voice quality problems are experienced with calls to voicemail or while recording calls. When on, the system signals silence by generating silence data packets in periods when the voicemail system is not playing prompts. Note that use of this option may cause some timeout routing options in voicemail to no longer work.</p>

*Table continues...*

Field	Description
<b>Analogue Trunk VAD</b>	<p>Default = Off.</p> <p>Select this option to enable Voice Activity Detection (VAD) for analog trunks terminating on the ATM4U-V2 card. VAD functionality provides a Call Answer signal triggered by voice activity. This signal can be used for:</p> <ul style="list-style-type: none"> <li>• Mobile Twinning</li> <li>• SMDR</li> <li>• Call Forwarding</li> <li>• Call Display</li> <li>• Mobile Call Control</li> <li>• Transfer Ringing Call</li> <li>• TAPI</li> <li>• Trunk to Trunk Call</li> </ul>
<b>Busy Tone Detection</b>	<p>Default = System Frequency (Tone defined by system locale) Allows configuration of the system's busy tone detection settings on lines that do not provide reliable disconnect signalling. In that case, the system will use tone disconnect clearing to disconnect such lines after 6 seconds of continuous tone. The default tone (frequency and on/off cadence) detection used is defined by the system locale. The settings should not be adjusted unless advised by Avaya Technical Support. Changes to this setting require a reboot rather than a merge when the new configuration is sent to the system. .For Server Edition this field is only available on Expansion System (V2) systems.</p>

*Table continues...*

Field	Description
<p><b>Hold Music</b></p>	<p>This section is used to define the source for the system's music on hold source. You must ensure that any MOH source you use complies with copyright, performing rights and other local and national legal requirements.</p> <p>Server Edition deployments support centralized music on hold, where the Primary Server streams music to the Secondary Server and all expansion servers.</p> <p>The WAV file properties must be:</p> <ul style="list-style-type: none"> <li>• PCM</li> <li>• 8kHz 16-bit</li> <li>• mono</li> <li>• maximum length 90 seconds (30 seconds on non-IP500 V2 systems, 600 seconds on Linux based systems)</li> </ul> <p>If the file downloaded is in the incorrect format, it will be discarded from memory after the download.</p> <p> <b>Caution:</b></p> <p>Copying files in the incorrect format directly into the <code>opt/ipoffice/system/primary</code> directory can disable the music on hold function.</p> <p>The first WAV file, for the system source, must be called <code>HoldMusic.wav</code>. Alternate source WAV files:</p> <ul style="list-style-type: none"> <li>• can be up to 27 IA5 characters</li> <li>• cannot contain spaces</li> <li>• any extension is allowed</li> <li>• case sensitive</li> </ul>
<p><b>System Source</b></p>	<p>Default = WAV File.</p> <p>Selects the default hold music source for most uses of music on hold. Note that changes to the <b>System Source</b> requires a reboot. The options are:</p> <ul style="list-style-type: none"> <li>• <b>WAV:</b> Use the WAV file <b>HoldMusic.wav</b>. This file is loaded via TFTP. Note that on Linux systems, the file name is case sensitive.</li> <li>• <b>WAV (restart):</b> Identical to WAV except that for each new listener, the file plays from the beginning. Not supported on IP500 V2 systems. Cannot be used as a centralized source.</li> <li>• <b>External:</b> Applicable to IP500 V2 systems. Use the audio source connected to the back of the control unit.</li> <li>• <b>Tone:</b> The use of a double beep tone (425Hz, 0.2/0.2/0.2/3.4 seconds on/off) can be selected as the system source. The hold music tone is automatically used if the system source is set to <b>WAV File</b> but the <code>HoldMusic.wav</code> file has not yet been successfully downloaded.</li> </ul>

*Table continues...*

Field	Description
<b>Alternate Sources</b>	<p>This is just a summary, for more details see <a href="#">Alternate Source</a> on page 622. The available options depends on the system type. On IP500 V2 systems, up to 3 additional sources can be specified. On Linux systems, up to 31 alternate sources can be specified. Note that adding and changing a source can be done using a merge but deleting a source requires a reboot.</p> <ul style="list-style-type: none"> <li>• <b>Number:</b> Assigned automatically by the system.</li> <li>• <b>Name:</b> Up to 31 characters This field is used to associate a name with the alternate source. That name is then used in the Hold Music Source field on Incoming Call Routes and Hunt Groups.</li> <li>• <b>Source:</b> Up to 31 characters. Defines the source for the music on hold.</li> </ul> <p>The options are listed below with a brief description. For more information, see <a href="#">Alternate Source</a> on page 622.</p> <ul style="list-style-type: none"> <li>- <b>WAV:</b> To specify a wav file, enter <b>WAV:</b> followed by the file name.</li> <li>- <b>XTN:</b> Any analog extension. Not applicable to Linux systems.</li> <li>- <b>WAVRST:</b> To specify a wav file, enter <b>WAVRST:</b> followed by the file name. Playback is started every time from the beginning. Not applicable to IP500 V2 systems.</li> <li>- <b>WAVDIR:</b> Multiple WAV file source. The WAV files must be stored in the directory <code>/disk/tones/mohwavdir</code> (file manager access) or <code>/opt/ipoffice/tones/mohwavdir/</code> (SSH access). Playback resumes from where it left off the last time. Not applicable to IP500 V2 systems.</li> <li>- <b>WAVDIRRST:</b> As per <b>WAVDIR</b> above, however playback is always started from the beginning. Not applicable to IP500 V2 systems.</li> <li>- <b>USB:</b> Supports multiple USB inputs. Enter <code>USB:&lt;number&gt;</code>. Not applicable to IP500 V2 systems.</li> <li>- <b>LINE:</b> In Server Edition networks, setting the Secondary Server and Expansion Server <b>Alternate Source</b> to <b>Line</b> allows the server to receive streamed audio from a source on the Primary Server. On the Secondary Server and Expansion Server, enter <code>Line:x,y</code> where <b>x</b> is the line number to the Primary Server and <b>y</b> is the MOH source number on the Primary Server.</li> </ul>

**Related links**

[Telephony](#) on page 233

**Ring Tones**

Navigation: [System](#) | [Telephony](#) | [Ring Tones](#)

**Additional configuration information**

For additional ring tone configuration information, see [Ring Tones](#) on page 619

## Configuration settings

Used to configure distinct ring tones for groups and incoming call routes. Ring tone override features are only supported on 1400 Series, 9500 Series and J100 Series (except J129) phones.

These settings are mergeable. Changes to these settings do not require a reboot of the system.

Field	Description
<b>Available Ring Tones</b>	In this table, the <b>Number</b> , <b>Name</b> , and <b>Source</b> values are system supplied. The <b>Name</b> value is used to create a ring tone plan.
<b>Ring Tone Plan</b>	<p>Use this table to specify available ring tones. Ring tones in this table can be applied to hunt groups and incoming call routes and by short codes.</p> <ul style="list-style-type: none"> <li>• <b>Number:</b> System supplied. The <b>Number</b> can be used in a short code by adding r(x) to the <b>Telephone Number</b> field, where x = 1 to 8 and specifies which ring tone plan to use.</li> <li>• <b>Name:</b> A descriptive name for where this ring tone is used. For example, the name of a hunt group. Each name in the table must be unique. Once configured in this table, ring tone names can be selected from the <b>Ring Tone Override</b> field at: <ul style="list-style-type: none"> <li>- <b>Group   Group</b></li> <li>- <b>Incoming Call Route   Standard</b></li> </ul> </li> <li>• <b>Ring Tone:</b> The list of ring tone names from the <b>Available Ring Tones</b> table.</li> </ul>

### Related links

[Telephony](#) on page 233

## SM

Navigation: **System | Telephony | SM**

Used to configure settings that apply to both SM lines.

These settings are not mergeable. Changes to these settings require a reboot of the system.

Field	Description
<b>Short Form Dialing Length</b>	<p>Default = 0. Range = 0 to 14.</p> <p>This number specifies the short-form dialing length for all Centralized users and Groups. Configuration of this field allows IP Office to treat the last N digits (where N is the number entered in this field) of each Centralized user's extension number as an alias to that user's extension number. For example, if a Centralized user's extension number is 5381111 and the Short Form Dialing Length is 4, the system will match calls to 1111 with this extension. When 1111 is dialed by another user on the system, entered from the autoattendant, or comes from the ICR, then in sunny-day that call will be sent to Session Manager with the number converted to 5381111 and in rainy-day it will target the extension 5381111 locally.</p>

*Table continues...*

Field	Description
<b>Branch Prefix</b>	<p>Default = Blank. Maximum range = 15 digits.</p> <p>This number is used to identify the IP Office system within the Avaya Aura® network. The branch prefix of each IP Office system must be unique and must not overlap. For example 85, 861 and 862 are okay, but 86 and 861 overlap. On calls routed via an SM Line, the branch prefix is added to the caller's extension number. You have the option to leave the Branch Prefix field blank. If you do not configure the branch prefix, the IP Office user extensions must be defined with the full enterprise number.</p>
<b>Local Number Length</b>	<p>Default = Blank (Off). Range = Blank or 3 to 9 in deployments with IP Office users and blank or 3 to 15 in deployments with only centralized users.</p> <p>This field sets the default length for extension numbers for extensions, users, and hunt groups added to the IP Office configuration. Entry of an extension number of a different length will cause an error warning by Manager.</p> <p>The number of digits entered in the <b>Branch Prefix</b> field plus the value entered in the <b>Local Number Length</b> field must not exceed 15 digits. You have the option to leave the <b>Local Number Length</b> field blank.</p>
<b>Proactive Monitoring</b>	<p>Default = 60 seconds. Range = 60 seconds to 100000 seconds.</p> <p>The Enterprise Branch system sends regular SIP OPTIONS messages to the SM line in order to check the status of line. This setting controls the frequency of the messages when the SM line is currently in service. Centralized SIP phones use their own settings.</p>
<b>Monitoring Retries</b>	<p>Default = 1. Range = 0 to 5.</p> <p>The number of times the Enterprise Branch system retries sending an OPTIONS request to Session Manager before the SM Line is marked out-of-service.</p>
<b>Reactive Monitoring</b>	<p>Default 60 seconds. Range = 10 to 3600 seconds.</p> <p>The Enterprise Branch system sends regular SIP OPTIONS messages to the SM line in order to check the status of line. This setting controls the frequency of the messages when the SM line is currently out of service. Centralized SIP phones use their own settings.</p>
<b>Failback Policy</b>	<p>Default = Auto.</p> <p>This field allows the administrator to choose between an automatic or manual failback policy on the IP Office. In deployments with Centralized phones, this field must be set consistently with the Failback Policy of the phones, which is configured via the Session Manager global settings in System Manager. The options are:</p> <ul style="list-style-type: none"> <li>• <b>Auto:</b> IP Office automatically brings the SM Line to 'In Service' status as soon as it detects via the Reactive Monitoring that the Session Manager is reachable</li> <li>• <b>Manual:</b> When an SM line is in "Out of Service" state, IP Office does not bring it back to "In Service" status based on automatic detection. IP Office keeps the SM Line in "Out of Service" state until the administrator manually initiates Failback of IP Office from Session Manager.</li> </ul>

**Related links**

[Telephony](#) on page 233

**Call Log**

Navigation: **System | Telephony | Call Log**

IP Office can store a centralized call log for you. The centralized call log contains up to 60 call records for your calls (Server Edition) or 30 call records (IP500 V2). Each new call record replaces the oldest previous record when it reaches the limit.

On Avaya phones with a fixed **Call Log** or **History** button (1400, 1600, 9500, 9600, J100 Series), that button can be used display your centralized call log. You can use the call log to make calls or to store contacts as a personal speed dial. You can also edit the call log to remove records. The same call log is also used if the user logs into one-X Portal.

**\* Note:**

Avaya Workplace Client also now uses the centralized call log.

The centralized call log moves with you if you log on and off from different phones and / or Avaya Workplace Client. This includes hot desking within a network.

The missed call count is updated per user and not per call when a centralized call log is enabled. The missed call count is the sum of all the missed calls from a user, even if some of those missed calls have been reviewed in the call history screen already.

The user's call log records are stored by the system that is their home system, that is, the one on which they are configured. When the user is logged in on another system, new call log records are sent to the user's home system, but using the time and date on the system where the user is logged in.

These settings are mergeable. Changes to these settings do not require a reboot of the system.

Field	Description									
<b>Default Centralized Call Log On</b>	<p>Default = On.</p> <p>When selected, each user is defaulted to have the system store a call log of their calls. This call log is accessible on the phone when the user is using a phone with a <b>Call Log</b> or <b>History</b> button. The use of centralized call logging can be enabled/disabled on a per user basis using the setting <b>User   Telephony   Call Log   Centralized Call Log</b>.</p>									
<b>Log Missed Calls Answered at Coverage</b>	<p>Default = Off.</p> <p>This setting controls how calls to a user, that are answered by a covering user should be logged in the centralized call log. This option applies for calls answered elsewhere (covered) by pickup, call coverage (call coverage buttons or coverage group), bridged appearance button, user BLF, voicemail, etc.</p>									
	<table border="1"> <thead> <tr> <th>Setting</th> <th>Targeted User</th> <th>Covering User</th> </tr> </thead> <tbody> <tr> <td>Off</td> <td>Nothing</td> <td>Answered Call</td> </tr> <tr> <td>On</td> <td>Missed Call</td> <td>Answered Call</td> </tr> </tbody> </table>	Setting	Targeted User	Covering User	Off	Nothing	Answered Call	On	Missed Call	Answered Call
	Setting	Targeted User	Covering User							
	Off	Nothing	Answered Call							
On	Missed Call	Answered Call								

*Table continues...*



Field	Description
<b>Log Missed Hunt Group Calls</b>	<p>Default = Off. By default, hunt group calls are not included in any user's centralized call log unless answered by the user. If this option is selected, a separate call log is kept for each hunt group of calls that are not answered by anyone. It includes hunt group calls that go to voicemail.</p> <p>If missed hunt group calls are also being logged, the system stores up to 10 call records for each hunt group. When this limit is reached, new call records replace the oldest record.</p> <p>Within the user call log settings (<b>User   Telephony   Call Log</b>), the list of hunt groups allows selection of which hunt groups' missed call records should be displayed as part of the user's centralized call log.</p>

### Related links

[Telephony](#) on page 233

## TUI

Navigation: **System | Telephony | TUI**

Used to configure system wide telephony user interface (TUI) options for 1400, 1600, 9500, 9600 and J100 Series phones (except the J129).

Use these settings to define the default phone display when feature menus are disabled. Note that for new users, the default phone display options are set to the system default values.

Feature menus can be disabled in one of two ways.

- Set **System | Telephony | TUI | Features Menu** to **Off**. Set **User | Telephony | TUI | User Setting** to **Same as System**.
- On **User | Telephony | TUI**, set **User Setting** to **Custom** and set **Features Menu** to **Off**.

### Configuration settings

These settings are mergeable. Changes to these settings do not require a reboot of the system.

Phone Type	Variable	Description
1400 1600	Display Name Preference	<p>Defines the default value of the User's Features &gt; Phone User &gt; Phone Screen Settings &gt; Display Name setting.</p> <p>Default = Off</p> <p>When enabled, displays the user name.</p>
9500 9608 9611	Column View Preference	<p>Defines the default value of the User's Features &gt; Phone User &gt; Phone Screen Settings &gt; Display Mode setting.</p> <p>Default = Dual</p> <p>Column view can be Single or Dual.</p>

*Table continues...*

Phone Type	Variable	Description
9621 9641	Quick Touch Panel Lines	<p>Defines the default value of the User's Features &gt; Phone User &gt; Phone Screen Settings &gt; Quick Touch Lines setting.</p> <p>Default = Optimize</p> <p>Sets the Quick Touch Panel number. The options are 1, 2, and Optimize. When set to Optimize:</p> <ul style="list-style-type: none"> <li>• 9621 = 1</li> <li>• 9641 = 2</li> </ul>

Field	Description
Time Format	<p>Default = Locale Defined.</p> <p>Set the system time format display. The default time format is defined by the <b>Locale</b> setting. You can override the default and set the time format to a 12- hour or 24-hour clock.</p>

**Features Menu Controls**

Features Menu	<p>Default = On</p> <p>When set to on, you can select to turn individual menus and features on users phone's on or off. The system level settings can be overridden at the individual user settings level if required for particular users. The following feature menus are listed:</p> <ul style="list-style-type: none"> <li>• <b>Basic Call Functions:</b> If selected, users can access menu options for call pickup, park, unpark and transfer to mobile functions.</li> <li>• <b>Advanced Call Functions:</b> If selected, users can access the menu options for do not disturb, account code, withhold number and internal auto-answer functions. Note, the <b>Account Code</b> menu is only shown if the system has been configured with accounts codes.</li> <li>• <b>Forwarding:</b> If selected, users the phone's menus for forwarding and follow me functions.</li> <li>• <b>Hot Desk Functions:</b> If selected, users can access the menu options for logging in and out.</li> <li>• <b>Passcode Change:</b> If selected, users can change their login code (security credentials) through the phone menus..</li> <li>• <b>Phone Lock:</b> If selected, users can access the menu options for locking the phone and for setting it to automatically lock.</li> <li>• <b>Self Administration:</b> If selected, users can access the phone's <b>Self-Administration</b> menu options.</li> <li>• <b>Voicemail Controls:</b> If set, users can access the <b>Visual Voice</b> option through the phone's <b>Features</b> menu.</li> </ul>
---------------	-------------------------------------------------------------------------------------------------------------------------------------------------------------------------------------------------------------------------------------------------------------------------------------------------------------------------------------------------------------------------------------------------------------------------------------------------------------------------------------------------------------------------------------------------------------------------------------------------------------------------------------------------------------------------------------------------------------------------------------------------------------------------------------------------------------------------------------------------------------------------------------------------------------------------------------------------------------------------------------------------------------------------------------------------------------------------------------------------------------------------------------------------------------------------------------------------------------------------------------------------------------------------------------------------------------------------------------------------------------------------------------------------------------------------------------------------------------------------------------------------------------------------------------------------------

*Table continues...*

Field	Description
<b>SIP Phone Options</b>	
<b>Application for Vantage</b>	<p>Default = Equinox on Vantage</p> <p>Select the application to be used on Avaya Vantage™. The system supports Avaya Vantage™ phones running either Avaya Vantage™ Connect or Avaya Workplace Client applications as the dialer application. This field sets which application is indicated in the auto-generated <code>K1xxSupgrade.txt</code> file the system provides to Avaya Vantage™ phones. If a mix of dialer applications is required, a static <code>K1xxSupgrade.txt</code> file needs to be used. The options on the interface are:</p> <ul style="list-style-type: none"> <li>• <b>Equinox on Vantage:</b> Select the option to use the Avaya Workplace Client client on Avaya Vantage™ device.</li> <li>• <b>Vantage Basic/Connect:</b> Select the option to use the Avaya Vantage™ Connect or Avaya Vantage™ Basic applications on Avaya Vantage™ device.</li> </ul> <p> <b>Note:</b></p> <p>This setting is not available for Avaya Vantage™ 3.0 version and above.</p>

**Related links**

[Telephony](#) on page 233

---

## Directory Services

Navigation: **System | Directory Services**

**Related links**

[System](#) on page 203

[LDAP](#) on page 251

[HTTP](#) on page 254

## LDAP

Navigation: **System | Directory Services | LDAP**

**Additional configuration information**

For additional configuration information, see [Centralized System Directory](#) on page 604.

**Configuration settings**

The system supports LDAP Version 2. LDAP (Lightweight Directory Access Protocol) is a software protocol for enabling anyone to locate organizations, individuals, and other resources such as files and devices in a network, whether on the Internet or on a corporate intranet. LDAP is a "lightweight" (smaller amount of code) version of DAP (Directory Access Protocol), which is part of X.500, a standard for directory services in a network. LDAP is lighter because in its initial version, it did not include security features.

The system supports the import of directory records from one system to another using HTTP. That includes using HTTP to import records that another system has learnt using LDAP. HTTP import,

which is simpler to configure, can be used to relay LDAP records with LDAP configured on just one system.

LDAP records can contain several telephone numbers. Each will be treated as a separate directory record when imported into the system directory.

In a network, a directory tells you where in the network something is located. On TCP/IP networks, including the Internet, the Domain Name System (DNS) is the directory system used to relate the domain name to a specific network address. However, you may not know the domain name. LDAP allows you to search for an individual without knowing where they're located (although additional information will help with the search).

An LDAP directory is organized in a simple "tree" hierarchy consisting of the following levels:

- The "root" directory (the starting place or the source of the tree), which branches out to
- Countries, each of which branches out to
- Organizations, which branch out to
- Organizational units (divisions, departments, and so forth), which branches out to (includes an entry for)
- Individuals (which includes people, files, and shared resources such as printers)

An LDAP directory can be distributed among many servers. Each server can have a replicated version of the total directory that is synchronized periodically. An LDAP server is called a Directory System Agent (DSA). An LDAP server that receives a request from a user takes responsibility for the request, passing it to other DSA's as necessary, but ensuring a single coordinated response for the user.

LDAP Directory Synchronization allows the telephone number Directory held in the Control Unit to be synchronized with the information on an LDAP server. The feature can be configured to interoperate with any server that supports LDAP Version 2.

These settings are mergeable. Changes to these settings do not require a reboot of the system.

Field	Description
<b>LDAP Enabled</b>	Default = Off  This option turns LDAP support on or off. The system uses LDAP Version 2. If the server being queried is an LDAP Version 3 server, support for LDAP Version 2 requests may need to be enabled on that server (all LDAP Version 3 servers support LDAP Version 2 but do not necessarily have it enabled by default).
<b>User Name</b>	Default = Blank  Enter the user name to authenticate connection with the LDAP database. To determine the domain-name of a particular Windows 2000 user look on the "Account" tab of the user's properties under "Active Directory Users and Computers". Note that this means that the user name required is not necessarily the same as the name of the Active Directory record. There should be a built-in account in Active Directory for anonymous Internet access, with prefix "IUSR_" and suffix server_name (whatever was chosen at the Windows 2000 installation). Thus, for example, the user name entered in this field might be: IUSR_CORPSERV@example.com

*Table continues...*

Field	Description
<b>Password</b>	<p>Default = Blank</p> <p>Enter the password to be used to authenticate connection with the LDAP database. Enter the password that has been configured under Active Directory for the above user. Alternatively an Active Directory object may be made available for anonymous read access. This is configured on the server as follows.</p> <p>In "Active Directory Users and Computers" enable "Advanced Features" under the "View" menu. Open the properties of the object to be published and select the "Security" tab. Click "Add" and select "ANONYMOUS LOGON", click "Add", click "OK", click "Advanced" and select "ANONYMOUS LOGON", click "View/Edit", change "Apply onto" to "This object and all child objects", click "OK", "OK", "OK".</p> <p>Once this has been done on the server, any record can be made in the User Name field in the System configuration form (however this field cannot be left blank) and the Password field left blank. Other non-Active Directory LDAP servers may allow totally anonymous access, in which case neither User Name nor Password need be configured.</p>
<b>Server IP Address</b>	<p>Default = Blank</p> <p>Enter the IP address of the server storing the database.</p>
<b>Server Port</b>	<p>Default = 389</p> <p>This setting is used to indicate the listening port on the LDAP server.</p>
<b>Authentication Method</b>	<p>Default = Simple</p> <p>Select the authentication method to be used. The options are:</p> <ul style="list-style-type: none"> <li>• <b>Simple</b>: clear text authentication</li> <li>• <b>Kerberos</b>: Not used.</li> </ul>
<b>Resync Interval (secs)</b>	<p>Default = 3600 seconds. Range = 60 to 99999 seconds.</p> <p>The frequency at which the system should resynchronize the directory with the server. This value also affects some aspects of the internal operation.</p> <p>The LDAP search inquiry contains a field specifying a time limit for the search operation and this is set to 1/16th of the resync interval. So by default a server should terminate a search request if it has not completed within 225 seconds (3600/16).</p> <p>The client end will terminate the LDAP operation if the TCP connection has been up for more than 1/8th of the resync interval (default 450 seconds). This time is also the interval at which a change in state of the "LDAP Enabled" configuration item is checked.</p>

*Table continues...*

Field	Description
<b>Search Base/Search Filter</b>	<p>Default = Blank These 2 fields are used together to refine the extraction of directory records. Basically the Base specifies the point in the tree to start searching and the Filter specifies which objects under the base are of interest. The search base is a distinguished name in string form (as defined in RFC1779).</p> <p>The Filter deals with the attributes of the objects found under the Base and has its format defined in RFC2254 (except that extensible matching is not supported). If the Search Filter field is left blank the filter defaults to "(objectClass=*)", this will match all objects under the Search Base. The following are some examples applicable to an Active Directory database.</p> <ul style="list-style-type: none"> <li>• To get all the user phone numbers in a domain:            Search Base: cn=users,dc=acme,dc=com            Search Filter: (telephonenumber=*)</li> <li>• To restrict the search to a particular Organizational Unit (eg office) and get cell phone numbers also:            Search Base: ou=holmdel,DC=example,DC=com            Search Filter: ( (telephonenumber=*)(mobile=*))</li> <li>• To get the members of distribution list "group1":            Search Base: cn=users,dc=example,dc=com            Search Filter:            (&amp;(memberof=cn=group1,cn=users,dc=example,dc=com)            (telephonenumber=*))</li> </ul>
<b>Number Attributes</b>	<p>: Default = see below</p> <p>Enter the number attributes the server should return for each record that matches the Search Base and Search Filter. Other records could be ipPhone, otherIpPhone, facsimileTelephoneNumber, otherfacsimileTelephone Number, pager or otherPager. The attribute names are not case sensitive. Other LDAP servers may use different attributes.</p> <p>By default the record is "telephoneNumber,otherTelephone,homePhone=H,otherHomePhone=H,mobile=M,otherMobile=M", as used by Windows 2000 Server Active Directory for Contacts.</p> <p>The optional "=string" sub-fields define how that type of number is tagged in the directory. Thus, for example, a cell phone number would appear in the directory as: John Birbeck M 7325551234</p>

**Related links**

[Directory Services](#) on page 251

**HTTP**

Navigation: **System | Directory Services | HTTP**

## Additional configuration information

For additional configuration information, see [Centralized System Directory](#) on page 604.

## Configuration settings

The system can use HTTP to import the directory records held by another system. Note that support for HTTP can be disabled. The setting **System | System | Avaya HTTP Clients Only** can restrict a system from responding to HTTP requests. The system's **Unsecured Interface** security settings also included controls for HTTP access (**HTTP Directory Read** and **HTTP Directory Write**).

For Server Edition, on Secondary Server, Expansion System (L) and Expansion System (V2) systems, the HTTP settings are automatically defaulted to obtain the system directory from the Primary Server.

These settings are mergeable. Changes to these settings do not require a reboot of the system.

Field	Description
<b>Directory Type</b>	<p>Default = None (No HTTP import)/IP Office SCN on Server Edition.</p> <p>Set whether HTTP import should be used and the method of importation. The options are:</p> <ul style="list-style-type: none"> <li>• <b>None</b>: Do not use HTTP import.</li> <li>• <b>IP Office</b>: Import from the system at the IP address set in the <b>Source</b> field.</li> <li>• <b>IP Office SCN</b>: Import from a system in a multi-site network. The <b>Source</b> field is used to select the <b>Outgoing Line</b> ID that matches the H.323 line to the remote system.</li> </ul>
<b>Source</b>	<p>Default = Blank/9999 on Server Edition.</p> <p>The form of this field changes according to the <b>Directory Type</b> selection above. For <b>IP Office</b> this field requires the IP address of the other system. For IP Office SCN, the outgoing group ID of the IP Office line to the remote system is used.</p>
<b>List</b>	<p>Default = All.</p> <p>This field sets what types of directory record should be imported. The options are:</p> <ul style="list-style-type: none"> <li>• <b>All</b>: Import the full set of directory records from the remote system.</li> <li>• <b>Config Only</b>: Import just directory records that are part of the remote system's configuration. Note that these will be treated as imported records and will not be added to the local systems own configuration records.</li> <li>• <b>LDAP Only</b>: Import just directory records that the remote system has obtained as the result of its own LDAP import. This allows LDAP directory records to be relayed from one system to another.</li> <li>• <b>HTTP Only</b>: Import just directory records that the remote system has obtained as the result of its own HTTP import. This allows HTTP directory records to be relayed from one system to another.</li> </ul>
<b>URI</b>	<p>Default = /system/dir/complete_dir_list?sdiat=true</p> <p>This field is for information only and cannot be adjusted. The path shown changes to match the <b>List</b> setting above.</p>

*Table continues...*

Field	Description
<b>Resync Interval (secs)</b>	Default = 3600 seconds. Set how often the system should request an updated import. When a new import is received, all previously imported records are discarded and the newly imported records are processed.
<b>HTTPS Enabled</b>	Default = On. Turns HTTPS support on or off for directory record import.
<b>Port Number</b>	Default = 443. The port used for the Directory import. When <b>HTTPS Enabled</b> is set to On, the default value is 443. When <b>HTTPS Enabled</b> is set to Off, the default value is 80.

**Related links**

[Directory Services](#) on page 251

## System Events

Navigation: **System | System Events**

The system supports a number of methods by which events occurring on the system can be reported. These are in addition to the real-time and historical reports available through the System Status Application (SSA).

**Related links**

[System](#) on page 203

[Configuration](#) on page 256

[Alarms](#) on page 257

## Configuration

Navigation: **System | System Events | Configuration**

This form is used for general configuration related to system alarms.

### Configuration Settings

These settings are not mergeable. Changes to these settings require a reboot of the system.

Field	Description
<b>SNMP Agent Configuration</b>	
<b>SNMP Enabled</b>	Default = Off. Enables support for SNMP. This option is not required if using SMTP or Syslog.
<b>Community (Read-only)</b>	Default = Blank. The SNMP community name to which the system belongs.

*Table continues...*



Field	Description												
<b>SNMP Port</b>	Default = 161. Range = 161, or 1024 to 65535. The port on which the system listens for SNMP polling.												
<b>Device ID</b>	This is a text field used to add additional information to alarms. If an SSL VPN is configured, Avaya recommends that the Device ID match an SSL VPN service Account Name. Each SSL VPN service account name has an associated SSL VPN tunnel IP address. Having the displayed Device ID match an SSL VPN service account name helps identify a particular SSL VPN tunnel IP address to use for remotely managing IP Office.												
<b>Contact</b>	This is a text field used to add additional information to alarms.												
<b>Location</b>	This is a text field used to add additional information to alarms.												
<b>QoS Parameters</b>													
<p>These parameters are used if the setting <b>System   LAN1   VoIP   Enable RTCP Monitor on Port 5005</b> is set to On. They are used as alarm thresholds for the QoS data collected by the system for calls made by Avaya H.323 phones and for phones using VCM channels. If a monitored call exceeds any of the threshold an alarm is sent to the System Status application. Quality of Service alarms can also be sent from the system using Alarms.</p> <ul style="list-style-type: none"> <li>• The alarm occurs at the end of a call. If a call is held or parked and then retrieved, an alarm can occur for each segment of the call that exceeded a threshold.</li> <li>• Where a call is between two extensions on the system, it is possible that both extensions will generate an alarm for the call.</li> <li>• An alarm will not be triggered for the QoS parameters recorded during the first 5 seconds of a call.</li> </ul>													
<b>Round Trip Delay (msec)</b>	<p>Default = 350.</p> <p>Less than 160ms is high quality. Less than 350ms is good quality. Any higher delay will be noticeable by those involved in the call. Note that, depending on the compression codec being used, some delay stems from the signal processing and cannot be removed: G.711 = 40ms, G.723a = 160ms, G.729 = 80ms.</p>												
<b>Jitter (msec)</b>	<p>Default =20.</p> <p>Jitter is a measure of the variance in the time for different voice packets in the same call to reach the destination. Excessive jitter will become audible as echo.</p>												
<b>Packet Loss (%)</b>	<p>Default = 3.0.</p> <p>Excessive packet loss will be audible as clipped words and may also cause call setup delays.</p> <table border="1"> <thead> <tr> <th></th> <th>Good Quality</th> <th>High Quality</th> </tr> </thead> <tbody> <tr> <td><b>Round Trip Delay</b></td> <td>&lt; 350ms</td> <td>&lt; 160ms</td> </tr> <tr> <td><b>Jitter</b></td> <td>&lt; 20ms</td> <td>&lt; 20ms</td> </tr> <tr> <td><b>Packet Loss</b></td> <td>&lt; 3%</td> <td>&lt; 1%</td> </tr> </tbody> </table>		Good Quality	High Quality	<b>Round Trip Delay</b>	< 350ms	< 160ms	<b>Jitter</b>	< 20ms	< 20ms	<b>Packet Loss</b>	< 3%	< 1%
	Good Quality	High Quality											
<b>Round Trip Delay</b>	< 350ms	< 160ms											
<b>Jitter</b>	< 20ms	< 20ms											
<b>Packet Loss</b>	< 3%	< 1%											

## Related links

[System Events](#) on page 256

## Alarms

Navigation: [System](#) | [System Events](#) | [Alarms](#)

These settings are not mergeable. Changes to these settings require a reboot of the system.

This form is used to configure what can cause alarms to be sent using the different alarm methods.

- Up to 5 alarm traps can be configured for use with the SNMP settings on the **System | System Events | Configuration** tab.
- Up to 3 email alarms can be configured for sending using the systems **System | SMTP** settings. The email destination is set as part of the alarm configuration below.
- Up to 2 alarms can be configured for sending to a Syslog destination that is included in the alarm settings.

### Configuration Settings

Field	Description
<b>New Alarm</b>	This area is used to show and edit the alarm.
<b>Destination</b>	
To use SNMP or Email the appropriate settings must be configured on the Configuration sub-tab. Note that the Destination type is grayed out if the maximum number of configurable alarms destinations of that type has been reached. Up to 5 alarm destinations can be configured for SNMP, 3 for SMTP email, and 2 for Syslog	
<b>Trap</b>	<p>If selected, the details required in addition to the selected Events are:</p> <ul style="list-style-type: none"> <li>• <b>Server Address:</b> Default = Blank. The IP address or fully qualified domain name (FQDN) of the SNMP server to which trap information is sent.</li> <li>• <b>Port:</b> Default = 162. Range = 0 to 65535. The SNMP transmit port.</li> <li>• <b>Community:</b> Default = Blank The SNMP community for the transmitted traps. Must be matched by the receiving SNMP server.</li> <li>• <b>Format:</b> Default = IP Office. The options are:                             <ul style="list-style-type: none"> <li>- <b>IP Office</b> SNMP event alarms format in accordance with IP Office.</li> <li>- <b>SMGR</b> SNMP event alarms format in accordance with SMGR.</li> </ul> </li> </ul>
<b>Syslog</b>	<p>If selected, the details required in addition to the selected Events are:</p> <ul style="list-style-type: none"> <li>• <b>IP Address:</b> Default = Blank. The IP address of the Syslog server to which trap information is sent.</li> <li>• <b>Port:</b> Default = 514. Range = 0 to 65535. The Syslog destination port.</li> <li>• <b>Protocol:</b> Default = UDP. Select UDP or TCP.</li> <li>• <b>Format:</b> Default = Enterprise. The options are:                             <ul style="list-style-type: none"> <li>- <b>Enterprise</b> Syslog event alarms format in accordance with Enterprise.</li> <li>- <b>IP Office</b> Syslog event alarms format in accordance with IP Office.</li> </ul> </li> </ul>
<b>Email</b>	<p>If selected, the details required in addition to the selected Events are:</p> <p><b>Email:</b> The destination email address.</p>

*Table continues...*

Field	Description
<b>Minimum Security Level</b>	<p>Default = Warnings.</p> <p>The options are:</p> <ul style="list-style-type: none"> <li>• <b>Warnings:</b> All events, from Warnings to Critical, are sent.</li> <li>• <b>Minor:</b> Minor, major, and critical events are sent. Warnings are not sent.</li> <li>• <b>Major:</b> Major and critical events are sent. Warnings and minor events will not be sent.</li> <li>• <b>Critical:</b> Only critical events are sent.</li> </ul>
<b>Events</b>	<p>Default = None</p> <p>Sets which types of system events should be collected and sent. The table below lists the alarms associated with each type of event. Text in italics in the messages is replaced with the appropriate data. Items in [] brackets are included in the message if appropriate. The subject line of SMTP email alarms takes the form "System name: IP address - System Alarm".</p>

Type	Events	Event State	Message
<b>Entity</b>	<b>Application</b>	Voicemail operation	The Voicemail server is now operational.
		Voicemail Failure	The Voicemail server is down.
		Voicemail Event - storage OK	The Voicemail server storage is OK.
		Voicemail Event - storage nearly full	The Voicemail server storage is nearly full.
		Voicemail Event - storage full	storage full The Voicemail server storage is full.
	<b>Service</b>	Feature license missing	Attempt to use a feature for which no license is installed. License Type: <name>
		All licenses in use	The following licenses are all in use. License Type: <name>
		Clock source changed	8kHz clock source changed. Details will be provided.
		Logon failed	Logon failure reason will be provided.
		No free channels available	No free channels were available. Outgoing group ID: <number>
		Hold music file failure	Failed to load Hold Music source file.
		All resources in use	The following system resources are all in use: <resource type> will be provided.

*Table continues...*

Type	Events	Event State	Message
		OEM card slot error	System running secondary software or error description with OEM card will be provided.
		Network interconnect failure	Details of the network interconnection failure will be provided.
		SIP message too large	SIP message Rx error - too large - ignored.
	<b>Contact Flash Card</b>	Change	The PC card in <i>name</i> has changed.
	<b>Expansion Module</b>	Operational	Expansion module <i>name</i> link is up.
		Failure	Expansion module <i>name</i> link is down.
		Error	Expansion module <i>name</i> link has a link error.
		Change	Expansion module <i>name</i> link has changed.
	<b>Trunk</b>	Operational	Trunk number (name) [on expansion module number] is now operational.
		Failure	Trunk number (name) [on expansion module number] is down.
	<b>Trunk</b>	Trunk seize failure	Seize failure: Channel [number] or Port [number].
		Incoming call outgoing trunk failure	Incoming call outgoing trunk: Channel [number] or Port [number].
		CLI not delivered	CLI not delivered: Channel [number] or Port [number].
		DDI incomplete	DDI incomplete. Expected Number of digits: .
		LOS	LOS
		OOS	OOS
		Red Alarm	Red Alarm
		Blue Alarm	Blue Alarm
		Yellow Alarm	Yellow Alarm
IP connection failure		IP connection failure. IP Trunk Line Number: <number> or Remote end IP address: <IP address>	

*Table continues...*

Type	Events	Event State	Message
		Small Community Network invalid connection	Small Community Network invalid connection. IP trunk line number: <number> or remote end IP address: <IP address>
	<b>Link</b>	Device changed	Device changed. Home Extension Number: .
		LDAP server communication failure	LDAP server communication failure
		Resource down	Link/resource down. Module type, number and name will be provided.
		SMTP server communication failure	SMTP server communication failure
		Voicemail Pro connection failure	Voicemail Pro connection failure
		Dialer connection failure	The Dialer connection has been lost.
	<b>VCM</b>	Operational	VCM module <i>name</i> is now operational.
		Failure	VCM module <i>name</i> has failed.
<b>Memory Card</b>	<b>Invalid Card</b>		
	<b>Free Capacity</b>		
<b>Generic</b>	<b>Generic</b>	Non-primary location boot alarm	System running backup software.
		Invalid SD Card	Incompatible or Invalid (System or Optional) SD Card fitted.
		Network link failure	Network Interface <i>name</i> (ip address) has been disconnected.
		Network link operational	Network Interface <i>name</i> (ip address) has been connected.
		System warm start	System has been restarted (warm start).
		System cold start	System has restarted from power fail (cold start).
		SNMP Invalid community	Invalid community specified in SNMP request.
<b>License</b>	<b>License Server</b>	Server Operational	The license server is now operational.
		Server failure	The license server is no longer operational.
	<b>License Key Failure</b>	License Key Failure	

Table continues...

Type	Events	Event State	Message
Loopback	Loopback	Near end line loopback	Trunk number ( <i>name</i> ) [on expansion module <i>number</i> ] is in near end loopback.
		Near end payload loopback	Trunk number ( <i>name</i> ) [on expansion module <i>number</i> ] is in near end loopback with payload.
		Loopback off	Trunk number ( <i>name</i> ) [on expansion module <i>number</i> ] has no loopback.
Phone Change	Phone Change	Phone has been unplugged	The phone with id <i>n</i> has been removed from extension <i>extension</i> ( <i>unit</i> , port <i>number</i> ).
		Phone has been plugged in	The phone with type <i>type</i> ( <i>id number</i> ) has been plugged in for extension <i>extension</i> ( <i>unit</i> , port <i>number</i> ).
Quality of Service	QoS Monitoring	If Enable RTCP Monitor on Port 5005 is selected, any monitored calls that exceeds the set QoS Parameters causes an alarm.	
Syslog	Basic Audit	Events as written to the system Audit Trail. Available on Syslog output only.	
	Extended Audit	Configuration change information. Each message contains one configuration or security settings object attribute change, and optionally the previous and new values.	
	System Monitor	If selected, System monitor traces are packed into Syslog traces.	
System	Configuration	CCR group agent is not targeted.  * <b>Note:</b> CCR is not supported in IP Office release 9.1 and later.	CCR Group agent not targeted as it is not an CCR Agent. Group: <name> Agents: <name1, ....., name n>.
		Small Community Network dial plan conflict	Small Community Network dial plan conflict
		No incoming call route for call	The following line had no Incoming Call Route for a call. Line: <number> or Line Group ID: <number>.
		Installed hardware failure	Installed hardware failure details will be provided.
	System Shutdown		
	Running Backup		

Table continues...

Type	Events	Event State	Message
	Emergency Calls	Emergency call successful	Successful Emergency Call   Emergency call! Location: <i>location</i> Dialled: <i>dialled number</i> Called: <i>number</i> sent on the line CallerID: <i>ID</i> Usr: <i>user</i> Extn: <i>extension</i>
		Emergency call failed	Failed Emergency Call   Emergency <i>call!</i> Location: <i>location</i> Dialled: <i>dialled</i> <i>number</i> FailCause: <i>cause</i> Usr: <i>user</i> Extn: <i>extension</i>

## Alarm Types

Note the following.

- **Voicemail Pro Storage Alarms:** The alarm threshold is adjustable through the Voicemail Pro client.
- **Embedded Voicemail Storage Alarms:** A disk full alarm is generated when the Embedded Voicemail memory card reaches 90% full. In addition a critical space alarm is generated at 99% full and an OK alarm is generated when the disk space returns to below 90% full.
- **Loopback:** This type of alarm is only available for systems with a United States locale.

The list of IP Office alarms is available on the Admin CD in the folder \snmp\_mibs\IPOffice.

## Related links

[System Events](#) on page 256

---

## SMTP

Navigation: **System | SMTP**

These settings are not mergeable. Changes to these settings require a reboot of the system.

### Configuration Settings

SMTP can be used as the method of sending system alarms. The email destination is set as part of the email alarms configured in **System | System Events | Alarms**.

SMTP can be used with Embedded Voicemail for Voicemail Email. The voicemail destination is set by the user's Voicemail Email address.

Field	Description
<b>Server Address</b>	Default = Blank  This field sets the IP address of the SMTP server being used to forward SNMP alarms sent by email.

*Table continues...*

Field	Description
<b>Port</b>	Default = 25. Range = 0 to 65534. This field set the destination port on the SMTP server.
<b>Email From Address</b>	Default = Blank This field set the sender address to be used with mailed alarms. Depending of the authentication requirements of the SMTP server this may need to be a valid email address hosted by that server. Otherwise the SMTP email server may need to be configured to support SMTP relay.
<b>Use STARTTLS</b>	Default = Off. (Release 9.0.3). Select this field to enable TLS/SSL encryption. Encryption allows voicemail-to-email integration with hosted email providers that only permit SMTP over a secure transport.
<b>Server Requires Authentication</b>	Default = Off This field should be selected if the SMTP server being used requires authentication to allow the sending of emails. When selected, the User Name and Password fields become available
<b>User Name</b>	Default = Blank This field sets the user name to be used for SMTP server authentication.
<b>Password</b>	Default = Blank This field sets the password to be used for SMTP server authentication.
<b>Use Challenge Response Authentication (CRAM-MD5)</b>	Default = Off. This field should be selected if the SMTP uses CRAM-MD5.

**Related links**

[System](#) on page 203

## System | SMDR

Navigation: **System | SMDR**

The system can be configured to output SMDR (Station Message Detail Reporting) records for each completed call.

These settings are mergeable. Changes to these settings do not require a reboot of the system.



Field	Description
<b>Output</b>	<p>Default = No Output.</p> <p>Select the type of call record that the system should create. The options are:</p> <ul style="list-style-type: none"> <li>• <b>No Output</b> – Do not generate SMDR records.</li> <li>• <b>SMDR Only</b> – Generate SMDR records and send those records using the settings below.</li> </ul>
<b>SMDR: Station Message Detail Recorder Communications</b>	
<p>This fields are available when SMDR is selected as the output. For information on SMDR record details, see the SMDR appendix.</p>	
<b>IP Address</b>	<p>Default = 0.0.0.0 (Listen).</p> <p>The destination IP address for SMDR records. Each time a new record is generated, the system will attempt to send the record to the address specified.</p> <ul style="list-style-type: none"> <li>• The address 0.0.0.0 puts the system into listen mode. Using an application such as HyperTerminal or Putty, a TCP/IP connection to the system's IP address and specified TCP port will collect any new and or buffered records.</li> <li>• Any other address puts the system into send mode. Each time a new record is generated, the system attempts to send the record to the specified address and port using a TCP/IP connection. If the connection is not successful, the record is buffered (see below) until a successful connection occurs for a subsequent new record.</li> </ul>
<b>TCP Port</b>	<p>Default = 0.</p> <p>The IP port for sending or collecting SMDR records.</p>
<b>Records to Buffer</b>	<p>Default = 500. Range = 10 to 3000.</p> <p>The system buffers new records when there is not TCP/IP connection. It can buffer up to 3000 SMDR records.</p> <p>If the cache is full, the system discards the oldest record each time a new record is added.</p>
<b>Call Splitting for Diverts</b>	<p>Default = Off.</p> <p>When enabled, for calls forwarded off-switch using an external trunk, the SMDR produces separate initial call and forwarded call records:</p> <ul style="list-style-type: none"> <li>• The two sets of records have the same <b>Call ID</b>.</li> <li>• The <b>Call Start Time</b> fields of the forwarded call records are reset from the moment of forwarding on the external trunk.</li> </ul> <p>This applies for:</p> <ul style="list-style-type: none"> <li>• Calls forwarded by forward unconditional, forward on no answer, forward on busy, DND or mobile twinning.</li> <li>• Calls forwarded off-switch by an incoming call route.</li> </ul>

**Related links**

[System](#) on page 203

## VCM

Navigation: **System | VCM**

This form allows adjustment of the operation of any Voice Compression Modules (VCM's) installed in a control unit.

Calls to and from IP devices can require conversion to the audio codec format being used by the IP device. For systems this conversion is done by voice compression channels. These support the common IP audio codecs G.711, G.723 and G.729a. For details of how to add voice compression resources to a system, refer to the IP Office Installation Manual.

These settings should only be adjusted under the guidance of Avaya support.

These settings are mergeable. Changes to these settings do not require a reboot of the system.

### When are Voice Compression Channels Used

**IP Device to Non-IP Device:** These calls require a voice compression channel for the duration of the call. If no channel is available, busy indication is returned to the caller.

**IP Device to IP Device:** Call progress tones (for example dial tone, secondary dial tone, etc) do not require voice compression channels with the following exceptions:

- Short code confirmation, ARS camp on and account code entry tones require a voice compression channel.
- Devices using G.723 require a voice compression channel for all tones except call waiting.

When a call is connected:

- If the IP devices use the same audio codec no voice compression channel is used.
- If the devices use differing audio codecs, a voice compression channel is required for each.

**Non-IP Device to Non-IP Device:** No voice compression channels are required.

**Music on Hold:** This is provided from the system's TDM bus and therefore requires a voice compression channel when played to an IP device.

**Conference Resources and IP Devices:** Conferencing resources are managed by the conference chip which is on the system's TDM bus. Therefore, a voice compression channel is required for each IP device involved in a conference. This includes services that use conference resources such as call listen, intrusion and silent monitoring. They also apply to call recording.

**Page Calls to IP Device:** Page calls require 1 voice compression channel per audio codec being used by any IP devices involved. The system only uses G.729a for page calls, therefore only requiring one channel but also only supporting pages to G.729a capable devices.

**Voicemail Services and IP Devices:** Calls to the system voicemail servers are treated as data calls from the TDM bus. Therefore calls from an IP device to voicemail require a voice compression channel.

**Fax Calls:** These are voice calls but with a slightly wider frequency range than spoken voice calls. The system only supports fax across IP between systems with the Fax Transport option selected.

**SIP Calls:**

- **SIP Line Call to/from Non-IP Devices:** Voice compression channel required.
- **Outgoing SIP Line Call from IP Device:** No voice compression channel required.
- **Incoming SIP Line Call to IP Device:** Voice compression channel reserved until call connected.

**T38 Fax Calls:** The system supports T38 fax on SIP trunks and SIP extensions. Each T38 fax call uses a VCM channel.

- Within a multi-site network, an T38 fax call can be converted to a call across across an H.323 line between systems using the **Fax Transport Support** protocol. This conversion uses 2 VCM channels.
- In order use T38 Fax connection, the **Equipment Classification** of an analog extension connected to a fax machine can be set **Fax Machine**. Additionally, the short code feature **Dial Fax** is available.

**Measuring Channel Usability**

The System Status Application can be used to display voice compression channel usage. Within the Resources section it displays the number of channel in use. It also displays how often there have been insufficient channels available and the last time such an event occurred.

Field	Description
<b>Echo Return Loss (dB)</b>	<p>Default = 6dB. IP500 VCM, IP500 VCM V2 and IP500 Combination Cards. This control allows adjustment of expected echo loss that should be used for the echo cancellation process.</p> <p>Echoes are typically generated by impedance mismatches when a signal is converted from one circuit type to another, most notably from analog to IP. To resolve this issue, an estimated echo signal can be created from one output and then subtracted from the input to hopefully remove any echo of the output.</p> <p>The options are:</p> <ul style="list-style-type: none"> <li>• <b>0dB</b></li> <li>• <b>3dB</b></li> <li>• <b>6dB</b></li> <li>• <b>9dB</b></li> </ul>

*Table continues...*

Field	Description
<b>Nonlinear Processor Mode</b>	<p>Default = Adaptive. I</p> <p>A low level of comfort noise is required on digital lines during periods where there would normally be just silence. This is necessary to reassure users that the call is still connected. These controls allow adjustment of the comfort noise generated by the nonlinear processor (NLP) component of the VCM. The options are:</p> <ul style="list-style-type: none"> <li>• <b>Adaptive:</b> Adaptive means the comfort noise generated by the NLP will try to match background noise.</li> <li>• <b>Silence:</b> Silence means the NLP will not generate comfort noise at all</li> <li>• <b>Disabled:</b> Nonlinear processing is not applied, in which case some residual echo may be heard.</li> </ul>
<b>NLP Comfort Noise Attenuation</b>	<p>Default = -9dB.</p> <p>The options are:</p> <ul style="list-style-type: none"> <li>• <b>-3dB</b></li> <li>• <b>-6dB</b></li> <li>• <b>-9dB</b></li> </ul>
<b>NLP Comfort Noise Ceiling</b>	<p>Default = -30dB.</p> <p>The options are:</p> <ul style="list-style-type: none"> <li>• <b>-30dB</b></li> <li>• <b>-55dB</b></li> </ul>
<b>Modem</b>	
<p>For Fax relay, these settings allow adjustment of the TDM side operation applied to fax calls using VCM channels.</p>	
<b>Tx Level (dB)</b>	Default = -9dB. Range = 0 to -13dB.
<b>CD Threshold</b>	Default = -43dB, Options = -26dB, -31dB or -43dB.
<b>No Activity Timeout (secs)</b>	Default = 30 seconds. Range = 10 to 600 seconds.

**Related links**

[System](#) on page 203

---

## Integrated Contact Reporter

Navigation: System | Contact Center | Integrated Contact Reporter

Integrated Contact Reporter is a simple Contact Center application that involves five to twenty five agents and up to five supervisors. The application collects and displays information on the current status of hunt groups and users that have been configured for Integrated Contact Reporter operation.

These settings are mergeable. Changes to these settings do not require a reboot of the system.

**\* Note:**

Integrated Contact Reporter is not supported in IP Office Release 11.0.

Field	Description
<b>Busy Not Available Reason Codes</b>	
Agents who indicate that they are in a 'busy not available' state can be prompt to also indicate the reason for being in that state. This menu allows descriptions for the possible reasons to be entered. The descriptions are then used in menus from which the Agent's make selections when setting themselves into busy not available state and in reports on Agent status.	
<b>Code/Reason</b>	Rows 1 to 8 can be used to contain descriptions of up to 31 characters each. Rows <b>0</b> and <b>9</b> are fixed as <b>Unsupported</b> and <b>Busy Not Available</b> .
<b>Default After Call Work Time (seconds)</b>	Default = 10. Range = 10 to 999 seconds. If an agent goes into the After Call Work (ACW) state, either automatically or manually, this field sets the duration of that state after which it is automatically cleared. This duration can be overridden by the Agent's own setting (User   Telephony   Supervisor Settings   After Call Work Time). During ACW state, hunt group calls are not presented to the user.

### Related links

[System](#) on page 203

## VoIP

Navigation: **System | VoIP**



This tab is used to set the codecs available for use with all IP (H.323 and SIP) lines and extensions and the default order of codec preference.

- Avaya H.323 telephones do not support G.723 and will ignore it if selected.
- For systems with H.323 lines and extensions, one of the G.711 codecs must be selected and used.
- G.723 and G.729b are not supported by Linux based systems.
- The number of channels provided by an IP500 VCM 32 or IP500 VCM 64 card, up to a maximum of 32 or 64 respectively, depends on the actual codecs being used. This also applies to IP500 VCM 32 V2 and IP500 VCM 64 V2 cards. The following table assumes that all calls using the VCM use the same codec.

Codec	IP500 VCM 32 V2	IP500 VCM 64 V2
<b>G.711</b>	32	64
<b>G.729a</b>	30	60
<b>G.723</b>	22	44
<b>G.722</b>	30	60

Paging from an IP device uses the preferred codec of that device. It is the system administrator's responsibility to ensure all the target phones in the paging group support that codec.

These settings are not mergeable. Changes to these settings require a reboot of the system.

Field	Description
<b>Ignore DTMF Mismatch For Phones</b>	<p>Default = On.</p> <p>When set to On, the following settings are visible and configurable:</p> <ul style="list-style-type: none"> <li>• <b>Extension   H.323 Extension   VoIP   Requires DTMF</b></li> <li>• <b>Extension   SIP Extension   VoIP   Requires DTMF</b></li> </ul> <p>When set to On, during media checks, the system ignores DTMF checks if the call is between two VoIP phones and the extension setting <b>Requires DTMF</b> is set to <b>Off</b>. The two phones can be located on different systems in a Server Edition or SCN deployment.</p> <p> <b>Note:</b></p> <p>Direct media may still not be possible if other settings, such as codecs, NAT settings, or security settings, are mismatched.</p>
<b>Allow Direct Media Within NAT Location</b>	<p>Default = Off.</p> <p>When set to On, the system allows direct media between devices that reside behind the same NAT. Devices are behind the same NAT if their public IP addresses are the same.</p> <p> <b>Note:</b></p> <p>Direct media may still not be possible if other settings, such as codecs, NAT settings, or security settings, are mismatched.</p> <p>The default behavior is to allow direct media between all types of devices (H323 and SIP remote workers and IP Office Lines behind a NAT). In the case of routers that have H323 or SIP ALG, it can be desirable to allow direct media only between certain categories of devices. This can be configured by adding the NoUser Source Number MEDIA_NAT_DM_INTERNAL. For information, see <b>User   Source Numbers</b>.</p>
<b>RFC2833 Default Payload</b>	<p>Default = 101. Range = 96 - 127.</p> <p>This field specifies the default value for RFC2833 dynamic payload negotiation. Service providers that do not support dynamic payload negotiation may require a fixed value.</p>

*Table continues...*

Field	Description
<b>Available Codecs</b>	<p>This list shows the codecs supported by the system and those selected as usable. Those codecs selected in this list are then available for use in other codec lists shown in the configuration settings. For example the adjacent <b>Default Selection</b> list and the individual custom selection list on IP lines and extensions.</p> <p> <b>Warning:</b></p> <p>Removing a codec from this list automatically removes it from the codec lists of any individual lines and extensions that are using it.</p> <p>The supported codecs (in default preference order) are: <b>G.711 A-Law</b>, <b>G.711 U-Law</b>, <b>G.722</b>, <b>G.729</b> and <b>G.723.1</b>. The default order for G.711 codecs will vary to match the system's default companding setting. <b>G.723.1</b> and <b>G.729b</b> are not supported on Linux based systems.</p>
<b>Default Codec Selection</b>	<p>By default, all IP (H.323 and SIP) lines and extensions added to the system have their <b>Codec Selection</b> setting set to <b>System Default</b>. That setting matches the codec selections made in this list. The buttons between the two lists can be used to move codecs between the <b>Unused</b> and the <b>Selected</b> parts of the list and to change the order of the codecs in the selected codecs list.</p>

#### Related links

[System](#) on page 203

## VoIP Security

Navigation: **System | VoIP Security**

Use to set system level media security settings. These settings apply to all lines and extensions on which SRTP is supported and which have their **Media Security** settings configured to be **Same as System**. Individual lines and extensions have media security settings that can override system level settings.

Simultaneous SIP extensions that do not have physical extensions in the configuration use the system security settings.

SM lines and all centralized user extensions must have uniform media security settings.

These settings are not mergeable. Changes to these settings require a reboot of the system.

Name	Description
<b>Default Extension Password</b>	<p>Default = Existing default extension password</p> <p>The field provides you with option to view and edit the existing default extension password. The default extension password is set up during IP Office installation either by the administrator or is randomly generated by the system. The system generated random password is of 10 digits. Use the Eye icon to see the existing default password. The password must be between 9 to 13 digits. The feature is not available in IP Office Basic Edition systems.</p>

*Table continues...*

## Configuration Mode Field Descriptions

Name	Description
<b>Confirm Default Extension Password</b>	If you are changing the default extension password, type the new default password.

*Table continues...*



Name	Description
<b>Media Security</b>	<p>Default = Disabled.</p> <p>Secure RTP (SRTP) can be used between IP devices to add additional security. These settings control whether SRTP is used for this system and the settings used for the SRTP. The options are:</p> <ul style="list-style-type: none"> <li>• <b>Same as System:</b> Matches the system setting at <b>System   VoIP Security</b>.</li> <li>• <b>Disabled:</b> Media security is not required. All media sessions (audio, video, and data) will be enforced to use RTP only.</li> <li>• <b>Preferred:</b> Media security is preferred. Attempt to use secure media first and if unsuccessful, fall back to non-secure media.</li> <li>• <b>Enforced:</b> Media security is required. All media sessions (audio, video, and data) will be enforced to use SRTP only.</li> </ul> <p> <b>Warning:</b></p> <p style="padding-left: 40px;">Selecting <b>Enforced</b> on a line or extension that does not support media security will result in media setup failures.</p> <p>If media security is enabled (<b>Enforced</b> or <b>Preferred</b>), it is recommended that you enable a matching level of security using <b>System   LAN   VoIP   H.323 Signalling over TLS</b>.</p> <p>The endpoints that support Secure RTP are:</p> <ul style="list-style-type: none"> <li>• IP Office Line</li> <li>• SIP Line</li> <li>• Avaya H.323 phones: <ul style="list-style-type: none"> <li>- 9608</li> <li>- 9611</li> <li>- 9621</li> <li>- 9641</li> </ul> </li> <li>• Avaya SIP phones: <ul style="list-style-type: none"> <li>- 9608, 9611, 9621, 9641 (in Centralized Branch environments)</li> <li>- 1100/1200 Series</li> <li>- Avaya B179</li> <li>- Avaya B199</li> <li>- E129 SIP Deskphone</li> <li>- Avaya J100 Series IP Phones</li> <li>- H175</li> <li>- Avaya Vantage™</li> <li>- Avaya Scopia® XT Series</li> </ul> </li> </ul>

*Table continues...*

Name	Description
	<ul style="list-style-type: none"> <li>• Avaya Workplace Client for Windows and iPad</li> <li>• one-X Mobile Preferred for IP Office on iOS and Android</li> <li>• Third party SIP extensions that support SRTP</li> </ul>
<b>Media Security Options</b>	<p>Not displayed if <b>Media Security</b> is set to <b>Disabled</b>. The options are:</p> <ul style="list-style-type: none"> <li>• <b>Encryptions:</b> Default = RTP This setting allows selection of which parts of a media session should be protected using encryption. The default is to encrypt just the RTP stream (the speech).</li> <li>• <b>Authentication:</b> Default = RTP and RTCP This setting allows selection of which parts of the media session should be protected using authentication.</li> <li>• <b>Replay Protection SRTP Window Size:</b> Default = 64. Currently not adjustable.</li> <li>• <b>Crypto Suites:</b> Default = SRTP_AES_CM_128_SHA1_80. There is also the option to select SRTP_AES_CM_128_SHA1_32.</li> </ul>
<b>Strict SIPS</b>	<p>(Enterprise Branch deployments) Default = Off.</p> <p>This option provides a system-wide configuration for call restrictions based on SIPS URI.</p> <p>When this option is off, calls are not rejected due to SIPS. A call is sent according to the configuration of the outgoing trunk or line that it is routed to, regardless of the way the call came in, even if the call came in as a SIP invite with SIPS URI and is being sent with a SIP URI onto a non-secure SIP trunk.</p> <p>When this option is on, an incoming SIP invite with SIPS URI if targeted to a SIP trunk (SM line or SIP line) is rejected if the target trunk is not configured with SIPS in the URI Type field.</p> <p> <b>Note:</b> Strict SIPS is not supported with 9600 Series and J100 Series SIP Feature phones.</p>

**Related links**

[System](#) on page 203

---

## Access Control Lists

Navigation: **System | VoIP**

Name	Description
<b>SIP UA Blacklist</b>	<p>The field to add SIP User Agent (UA) strings. The strings listed here are used to block the registration of SIP devices when the system's Allowed SIP User Agents setting is set to Block Blacklist only. Use the Add button to add a <b>Blacklist Entry Name</b> to the list.</p>

*Table continues...*

Name	Description
<b>SIP UA Whitelist</b>	The field to add SIP UA Whitelist strings. SIP User Agent (UA) strings listed here are used to allow the registration of SIP devices when the system's Allowed SIP User Agents setting is set to Avaya Clients & Whitelisted or Whitelisted Only. Use the Add button to add a <b>Whitelist Entry Name</b> to the list.
<b>IP Whitelist</b>	The system can automatically blacklist traffic from an IP address based on too many failed registration attempts from that address. This list can be used to create a list of addresses which should not be blacklisted. This may be useful when there are multiple devices registering from behind the same single public IP address, a scenario where there may be a higher incidence of unintended registration failures during initial setup. Use the Add button to add a <b>IP Address Entry Value</b> to the list.

### Related links

[System](#) on page 203

## Dialer

Navigation: **System | Dialer**

Use to configure the functions required for an Outbound Contact Express deployment.

These settings are mergeable. However, changes to the **Operation** field or to the **Trunk Range / IP Office** table require a reboot.

It is recommended that you do not change the mergeable settings while the system is in use.

Field	Description
<b>Operation</b>	Default = Off.  On the primary IP Office Server Edition server, set this field to <b>Primary</b> . For all other IP Office servers, set this field to <b>Child</b> . When set to <b>Off</b> or <b>Child</b> , no other fields are displayed.
<b>Record Mode</b>	Default = Off  Defines the automatic call recording function on VMPro. The options are: <ul style="list-style-type: none"> <li>• <b>Whole Call</b>: The entire call is recorded.</li> <li>• <b>Agent Connected</b>: Recording starts once the conversation begins.</li> <li>• <b>Off</b></li> </ul>
<b>Record Controls</b>	: Default = Full Defines what functions an agent can perform from WebAgent or from the handset. The options are: <ul style="list-style-type: none"> <li>• <b>Full</b></li> <li>• <b>Pause</b></li> <li>• <b>Off</b></li> </ul>

*Table continues...*

Field	Description																								
<b>Record Mode and Record Controls</b>	<p><b>Record Mode</b> and <b>Record Controls</b> are related. The combined configuration settings are listed below.</p> <p>Note that stopping and starting the recording creates multiple recording files. Pausing and resuming the recording keeps the recording in a single file.</p>																								
	<table border="1"> <thead> <tr> <th>Record Mode</th> <th>Record Controls</th> <th>Result</th> </tr> </thead> <tbody> <tr> <td>Off</td> <td>Off</td> <td>Calls are not recorded.</td> </tr> <tr> <td>Agent Connected</td> <td>Off</td> <td>All calls are always recorded from the time the agent joins the call.</td> </tr> <tr> <td>Agent Connected</td> <td>Pause</td> <td>All calls are always recorded but the Agent can pause and resume recording.</td> </tr> <tr> <td>Agent Connected</td> <td>Full</td> <td>All calls are always recorded from the time the Agent joins the call. Agent has full control on when calls get recorded.</td> </tr> <tr> <td>Whole Call</td> <td>Off</td> <td>All calls are always recorded from the time the customer answers.</td> </tr> <tr> <td>Whole Call</td> <td>Pause</td> <td>All calls are always recorded from the time the customer answers but the Agent can pause and resume the recording.</td> </tr> <tr> <td>Whole Call</td> <td>Full</td> <td>Call recording starts before the agent is connected. All calls are always recorded but the Agent can pause and resume the recording.</td> </tr> </tbody> </table>	Record Mode	Record Controls	Result	Off	Off	Calls are not recorded.	Agent Connected	Off	All calls are always recorded from the time the agent joins the call.	Agent Connected	Pause	All calls are always recorded but the Agent can pause and resume recording.	Agent Connected	Full	All calls are always recorded from the time the Agent joins the call. Agent has full control on when calls get recorded.	Whole Call	Off	All calls are always recorded from the time the customer answers.	Whole Call	Pause	All calls are always recorded from the time the customer answers but the Agent can pause and resume the recording.	Whole Call	Full	Call recording starts before the agent is connected. All calls are always recorded but the Agent can pause and resume the recording.
	Record Mode	Record Controls	Result																						
	Off	Off	Calls are not recorded.																						
	Agent Connected	Off	All calls are always recorded from the time the agent joins the call.																						
	Agent Connected	Pause	All calls are always recorded but the Agent can pause and resume recording.																						
	Agent Connected	Full	All calls are always recorded from the time the Agent joins the call. Agent has full control on when calls get recorded.																						
	Whole Call	Off	All calls are always recorded from the time the customer answers.																						
	Whole Call	Pause	All calls are always recorded from the time the customer answers but the Agent can pause and resume the recording.																						
Whole Call	Full	Call recording starts before the agent is connected. All calls are always recorded but the Agent can pause and resume the recording.																							
<b>Agent Call Back Time</b>	<p>Default = 60. Range = 30 - 300.</p> <p>The number of seconds an agent has to make a manual call after a customer hang up. Used when a customer wants to be called on a different number.</p>																								
<b>Remote Agent Display Text</b>	<p>Default = Blank. Maximum length = 33.</p> <p>Specify the text string displayed on the remote agent extension if that extension supports displays and the protocol allows it to be transmitted.</p>																								
<b>Remote Agent Confirmation Voice Prompt</b>	<p>Default = Blank. Maximum length = 31.</p> <p>Specify the Call Flow Entry point name used to play a greeting to the remote agent when they log in. The actual Entry Point is added as a Modules Entry point using the VMPro Client. The entry point cannot be added as a short code, user or group entry point.</p>																								

*Table continues...*

Field	Description
<b>Remote Agent First Extension Number</b>	Default = 0. The first extension number allocated to a remote agent. It must not conflict with the existing dialing plan. If the range contains existing user extensions, they are used when assigning extensions to remote users.
<b>Remote Agent Number of Extensions</b>	Default = 0. Maximum = 500. The range of extensions starting from the one above. A user is created for every extension. If the field is edited and the number of extensions is reduced, the number of remote agents that can log in is reduced to the new setting. However, reducing the range does not automatically delete previously created users. Users can only be deleted manually.
<b>Use Custom Hold Treatment</b>	Default = unchecked. Defines system behavior when a call is placed on hold. When unchecked the the system <b>Hold Music</b> setting is used for the system's music on hold source. When checked, the music on hold source is VMPro.
<b>Record while on Hold</b>	Default = unchecked. When the <b>Use Custom Hold Treatment</b> box is checked, the <b>Record while on Hold</b> setting can be enabled. When unchecked, recording is paused when the call is on hold. When checked, recording continues when the call is on hold.
<b>Trunk Range / IP Office</b>	The number of trunks used by Outbound Contact Express. The default entry is <b>Trunk Range: 1-250</b> for the Primary ( <b>Local</b> ) server. 250 is the maximum number of trunks configured on a single server. Use this table to define the number of trunks managed by the Primary and Secondary systems. The trunk range must match the line numbers used by the Proactive Contact Dialer. Enter only one range per server.

### Related links

[System](#) on page 203

## Contact Center

Navigation: **System | Contact Center**

The Contact Center tab contains the user information required by IP Office to synchronize account information with an Avaya Contact Center Select (ACCS) system. The information is synchronized using the Contact Center Management Application (CCMA). These settings are only used for the deployment of an ACCS system.

This tab is visible on the Server Edition Primary Server and Standard Mode IP500 V2 systems.

These settings are mergeable. Changes to these settings do not require a reboot of the system.

Field	Description
<b>Contact Center Application</b>	Default = None. The options are: <ul style="list-style-type: none"> <li>• Avaya Contact Center Select</li> <li>• Avaya IP Office Contact Center</li> <li>• Integrated Contact Reporter (not supported in IP Office Release 11.0)</li> </ul>

*Table continues...*

Field	Description
<b>Synchronize to this System</b>	Default = Off. When set to On, the CCMA fields below are enabled.
<b>CCMA Address</b>	Default = Blank Address of the Contact Center Management Application system.
<b>CCMA Username</b>	Default = Blank User name on the Contact Center Management Application system.
<b>CCMA Password</b>	Default = Blank Password on the Contact Center Management Application system.
<b>Default After Call Work Time</b>	Applicable for Integrated Contact Reporter Default = 10 seconds, Minimum = 10 seconds, Maximum = 999 seconds The default time set for After Call Work (ACW). If configured, ACW begins at the end of a call. Hunt group calls are not sent to the agent during ACW.  * <b>Note:</b> Integrated Contact Reporter is not supported in IP Office Release 11.0.
<b>Busy Not Available Reason Codes</b>	Applicable for Integrated Contact Reporter Default = 2 codes Maximum = 9 codes The reasons for 0 and 9 are assigned by default and cannot be modified. You can configure the rest. Use the configure icon to add Busy Not Available reasons and assign them to the available codes.  * <b>Note:</b> Integrated Contact Reporter is not supported in IP Office Release 11.0.

**Related links**

[System](#) on page 203

---

## Avaya Cloud Services

Navigation: **System > Avaya Cloud Services**

The **Avaya Cloud Services** tab contains configuration settings for user information synchronization with Avaya Spaces server. IP Office users created for Avaya Workplace Client must be synchronized with the Avaya Spaces server before using Avaya Workplace Client in a cloud environment. User synchronization can be done manually or automatically.

\* **Note:**

Avaya Cloud Account Authorization works only on TLS transport type.

**Related links**

[System](#) on page 203

# Line

The line settings shown in the system configuration will change according to the types of trunk cards installed in the control unit or added using external expansion modules.

**⚠ Warning:**

**Changing Trunk Cards** Changing the trunk card installed in an control unit will result in line settings for both the previous trunk card and the currently installed trunk card. In order to change the trunk card type in a particular card slot, the configuration must be defaulted. This does not apply if replacing an existing card with one of a higher capacity or fitting a trunk card into a previously unused slot.

**Trunk Incoming Call Routing**

Each trunk type can be categorized as either an external trunk or internal trunk. The trunk type affects how the system routes calls received on that trunk and the routing of calls to the trunk.

	External Trunks	Internal Trunks
<b>Trunk Types</b>	<b>Analog trunks</b> <b>T1 Robbed Bit</b> <b>E1R2</b> <b>ISDN BRI (excluding So)</b> <b>ISDN PRI T1</b> <b>ISDN PRI E1</b> <b>SIP</b>	<b>QSIG (T1, E1 or H.323)</b> <b>BRI So</b> <b>H.323</b> <b>SCN</b> <b>SES</b> <b>IP Office Line</b>
<b>Incoming Calls Routed by</b>	All incoming calls are routed by comparison of call details for matches within the system Incoming Call Routes. Line short codes are not used.	Incoming calls are routed by looking for a match to the incoming digits in the following order: <ul style="list-style-type: none"> <li>• Extension number.</li> <li>• Trunk short codes (excluding ? short code).</li> <li>• System short codes (excluding ? short code).</li> <li>• Trunk ? short code.</li> <li>• System ? short code.</li> </ul>

## Line Groups

Each system trunk (or in some cases individual trunk channels) can be configured with an **Incoming Group ID** and an **Outgoing Group ID**. These group IDs are used as follows:

- Incoming Call Routes For incoming calls on external trunks, the Incoming Group ID of the trunk is one of the factors used to match the call to one of the configured incoming call routes.
- Short Codes - Routing Outgoing Calls For dialing which matches a short code set to a **Dial** feature, the short codes **Line Group ID** can indicate either an ARS form or to use a trunk from set to the same **Outgoing Group ID**. If the call is routed to an ARS form, the short codes in the ARS form will specify the trunks to use by matching **Outgoing Group ID**.

## Removing Unused Trunks

In cases where a trunk card is installed but the trunk is not physically connected, it is important to ensure that the trunk is disabled in the configuration. This can be done on most trunks using by setting the line's **Admin** setting to **Out of Service**.

This is especially important with analog trunks. Failure to do this may cause the system to attempt to present outgoing calls to that trunk. Similarly, where the number of channels subscribed is less than those supportable by the trunk type, the unsubscribed channels should be disabled.

## Clock Quality

Calls between systems using digital trunks (for example E1, E1R2, T1 PRI and BRI) require an common clock signal. The system will try to obtain this clock signal from an exchange through one of its digital trunks. This is done by setting the Clock Quality setting of that Line to Network. If there are multiple trunks to public exchanges, another trunk can be set as Fallback should the primary clock signal fail. Other trunks should be set as Unsuitable.

## Related links

[Configuration Mode Field Descriptions](#) on page 197

[Analog Line](#) on page 280

[BRI Line](#) on page 289

[PRI Trunks](#) on page 294

[S0 Line](#) on page 325

[H.323 Line](#) on page 328

[IP DECT Line](#) on page 334

[SIP Line](#) on page 339

[SIP DECT Line](#) on page 373

[SM Line](#) on page 375

[IP Office Line](#) on page 384

---

## Analog Line

Analog trunks can be provided within the systems in the following ways. In all cases the physical ports are labeled as Analog. For full details of installation refer to the IP Office Installation manual.



**Using ICLID:** The system can route incoming calls using the ICLID received with the call. However ICLID is not sent instantaneously. On analog trunks set to Loop Start ICLID, there will be a short delay while the system waits for any ICLID digits before it can determine where to present the call.

**Line Status:** Analog line do not indicate call status other than whether the line is free or in use. Some system features, for example retrieving unanswered forwards and making twinned calls make use of the call status indicated by digital lines. This is not possible with analog lines. Once an analog line has been seized, the system has to assume that the call is connected and treats it as having been answered.

**Dialing Complete:** The majority of North-American telephony services use en-bloc dialing. Therefore the use of a ; is recommended at the end of all dialing short codes that use an N. This is also recommended for all dialing where secondary dial tone short codes are being used.

**Ground Start:** This type of analog trunk is only supported through the Analog Trunk external expansion module.

### Related links

[Line](#) on page 279

[Line Settings](#) on page 281

[Analog Options](#) on page 283

## Line Settings

Navigation: [Line](#) | [Analog Line](#) | [Line Settings](#)

### Configuration Settings

These settings are mergeable with the exception of the **Network Type** setting. Changes to this setting will require a reboot of the system.

Field	Description
<b>Line Number</b>	This parameter is not configurable, it is allocated by the system.
<b>Card/Module</b>	Indicates the card slot or expansion module being used for the trunk device providing the line. For IP500 V2 control units: 1 to 4 match the slots on the front of the control unit from left to right. Expansion modules are numbered from 5 upwards, for example trunks on the module in Expansion Port 1 are shown as 5.
<b>Port</b>	Indicates the port on the Card/Module above to which the configuration settings relate.

*Table continues...*

Field	Description
<b>Network Type</b>	<p>Default = Public.</p> <p>This option is available if <b>System   Telephony   Telephony   Restrict Network Interconnect</b> is enabled. It allows the trunk to be set as either <b>Public</b> or <b>Private</b>. The system will return number busy indication to any attempt to connect a call on a <b>Private</b> trunk to a <b>Public</b> trunk or vice versa. This restriction includes transfers, forwarding and conference calls.</p> <p>Due to the nature of this feature, its use is not recommended on systems also using any of the following other system features: multi-site networks, VPNremote, application telecommuter mode.</p>
<b>Telephone Number</b>	Used to remember the external telephone number of this line to assist with loop-back testing. For information only.
<b>Incoming Group ID</b>	Default = 0, Range 0 to 99999. The Incoming Group ID to which a line belongs is used to match it to incoming call routes in the system configuration. The matching incoming call route is then used to route incoming calls. The same ID can be used for multiple lines.
<b>Outgoing Group ID</b>	<p>Default = 1. Range 0 to 99999.</p> <p>Short codes that specify a number to dial can specify the line group to be used. The system will then seize a line from those available with a matching Outgoing Group ID.</p> <p>In a Server Edition/Select network, the <b>Outgoing Group ID</b> used for lines to a system must be unique within the network. The same ID cannot be used in the configuration of any lines to another server system in the network.</p> <p><b>Reserved Group ID Numbers:</b></p> <ul style="list-style-type: none"> <li>• <b>90000 - 99999</b> Reserved for system use (not enforced).</li> <li>• <b>99999 and 99998</b> In a Server Edition/Select network, reserved for the IP Office lines to the primary and secondary server respectively.</li> <li>• <b>99001 to 99148</b> In a Server Edition/Select network, reserved for the IP Office lines from the primary and secondary servers to each expansion system in the network.</li> <li>• <b>0</b> In a Server Edition/Select network, the ID 0 cannot be used.</li> <li>• <b>98888</b> For IP Office deployed in an Enterprise Branch environment, reserved for the SM line.</li> </ul>
<b>Outgoing Channels</b>	Default = 1 (not changeable)
<b>Voice Channels</b>	Default = 1 (not changeable)
<b>Prefix</b>	<p>Default = Blank</p> <p>Enter the number to prefix to all incoming numbers for callback. This is useful if all users must dial a prefix to access an outside line. The prefix is automatically placed in front of all incoming numbers so that users can dial the number back.</p> <p>For outgoing calls: The system does not strip the prefix, therefore any prefixes not suitable for external line presentation should be stripped using short codes.</p>

*Table continues...*

Field	Description
<b>Line Appearance ID</b>	Default = Auto-assigned. Range = 2 to 9 digits. Allows a number to be assigned to the line to identify it. On phones that support call appearance buttons, a Line Appearance button with the same number will show the status of the line and can be used to answer calls on the line. The line appearance ID must be unique and not match any extension number.
<b>Admin</b>	Default = In Service.  This field allows a trunk to be taken out of service if required for maintenance or if the trunk is not connected.

### Related links

[Analog Line](#) on page 280

## Analog Options

Navigation: [Line](#) | [Analog Line](#) | [Analog Options](#)

Covers analog line specific settings. The system wide setting **System | Telephony | Tones & Music | CLI Type** is used for to set the incoming CLI detection method for all analogue trunks.

The **Allow Analog Trunk to Trunk Connect** setting is mergeable. The remaining settings are not mergeable. Changes to these settings will require a reboot of the system.

Field	Description
<b>Channel</b>	Set by the system. Shown for information only.
<b>Trunk Type</b>	Default = Loop Start  Sets the analog line type. The options are: <ul style="list-style-type: none"> <li>• <b>Ground Start:</b> Ground Start is only supported on trunks provided by the Analog Trunk 16 expansion module. It requires that the module and the control unit are grounded. Refer to the IP Office installation manual.</li> <li>• <b>Loop Start</b></li> <li>• <b>Loop Start ICLID:</b> As the system can use ICLID to route incoming calls, on analog Loop Start ICLID trunks there is a few seconds delay while ICLID is received before the call routing can be determined.</li> </ul>
<b>Signaling Type</b>	Default = DTMF Dialing  Sets the signaling method used on the line. The options are: <ul style="list-style-type: none"> <li>• <b>DTMF Dialing</b></li> <li>• <b>Pulse Dialing</b></li> </ul>

*Table continues...*

Field	Description
<b>Direction</b>	<p>Default = Both Directions</p> <p>Sets the allowed direction of operation of the line. The options are:</p> <ul style="list-style-type: none"> <li>• <b>Incoming</b></li> <li>• <b>Outgoing</b></li> <li>• <b>Both Directions</b></li> </ul>
<b>Flash Pulse Width</b>	<p>Default = 0. Range = 0 to 2550ms.</p> <p>Set the time interval for the flash pulse width.</p>
<b>Await Dial Tone</b>	<p>Default = 0. Range = 0 to 25500ms.</p> <p>Sets how long the system should wait before dialing out.</p>
<b>Echo Cancellation</b>	<p>Default = 16ms.</p> <p>The echo cancellation should only be adjusted as high as required to remove echo problems. Setting it to a higher value than necessary can cause other distortions. Not used with external expansion module trunks. The options are (milliseconds):</p> <ul style="list-style-type: none"> <li>• <b>Off</b></li> <li>• <b>8</b></li> <li>• <b>16</b></li> <li>• <b>32</b></li> <li>• <b>64</b></li> <li>• <b>128</b></li> </ul>
<b>Echo Reduction</b>	<p>Default = On. (ATM4Uv2 card only)</p> <p>Used when impedance matching is not required but echo reduction is.</p>
<b>Mains Hum Filter</b>	<p>Default = Off.</p> <p>If mains hum interference on the lines is detected or suspected, this settings can be used to attempt to remove that interference. Useable with ATM16 trunks and IP500 ATM4U trunks. The options are:</p> <ul style="list-style-type: none"> <li>• <b>Off</b></li> <li>• <b>50Hz</b></li> <li>• <b>60Hz</b></li> </ul>
<b>Impedance</b>	<p>Set the impedance used for the line. This field is only available for system locales where the default value can be changed.</p> <p>The value used for <b>Default</b> is set by the setting <b>System   System   Locale</b>. For information, see <i>Avaya IP Office™ Platform Locale Settings</i>.</p> <p>The following values are used for <b>Automatic Impedance Matching</b>: 600+2150nF, 600, 900+2150nF, 900, 220+820  115nF, 370+620  310nF, 270+750  150nF, 320+1050  230nF, 350+1000  210nF, 800+100  210nF.</p>

Table continues...

Field	Description
<b>Quiet Line</b>	This field is only available for certain system locales (see above). The setting may be required to compensate for signal loss on long lines.
<b>Digits to break dial tone</b>	<p>Default = 2. Range = Up to 3 digits.</p> <p>During automatic impedance testing (see below), once the system has seized a line, it dials this digit or digits to the line. In some cases it may be necessary to use a different digit or digits. For example, if analog trunk go via another PBX system or Centrex, it will be necessary to use the external trunk dialing prefix of the remote system plus another digit, for example 92.</p>
<b>Automatic</b>	<p>Default = Yes. (ATM4Uv2 card only)</p> <p>When set to <b>Yes</b>, the <b>Default</b> value is used. The value used for <b>Default</b> is set by the system <b>Locale</b>.</p> <p>When set to <b>No</b>, the <b>Impedance</b> value can be manually selected from the list of possible values:</p> <p>600</p> <p>900 270+(750R    150nF) and 275R + (780R    150nF)</p> <p>220+(820R    120nF) and 220R+ (82R    115nF)</p> <p>370+(620R    310nF)</p> <p>320+(1050R    230nF)</p> <p>370+(820R    110nF)</p> <p>275+(780R    115nF)</p> <p>120+(820R    110nF)</p> <p>350+(1000R    210nF)</p> <p>200+(680R    100nF)</p> <p>600+2.16µF</p> <p>900+1µF</p> <p>900+2.16µF</p> <p>600+1µF Global Impedance</p>

*Table continues...*

Field	Description
<p><b>Automatic Balance Impedance Match</b></p>	<p>These controls can be used to test the impedance of a line and to then display the best match resulting from the test. Testing should be performed with the line connected but the system otherwise idle. To start testing click <b>Start</b>. The system will then send a series of signals to the line and monitor the response, repeating this at each possible impedance setting. Testing can be stopped at any time by clicking <b>Stop</b>. When testing is complete, Manager will display the best match and ask whether that match should be used for the line. If <b>Yes</b> is selected, Manager will also ask whether the match should be applied to all other analog lines provided by the same analog trunk card or module.</p> <p>Note that on the Analog Trunk Module (ATM16), there are four control devices, each supporting four channels. The impedance is set by the control device for all four channels under its control. Consequently, the impedance match tool only functions on lines 1, 5, 9, and 13.</p> <p>Before testing, ensure that the following system settings are correctly set:</p> <ul style="list-style-type: none"> <li>• <b>System   System   Locale</b></li> <li>• <b>System   Telephony   Telephony   Companding Law</b></li> </ul> <p>If either needs to be changed, make the required change and save the setting to the system before proceeding with impedance matching.</p> <p>Due to hardware differences, the impedance matching result will vary slightly depending on which type of trunk card or expansion module is being used.</p> <p><b>Automatic Balance Impedance Matching, Quiet Line and Digits to break dial tone</b> are available for the Bahrain, Egypt, French Canadian, India, Kuwait, Morocco, Oman, Pakistan, Qatar, Saudi Arabia, South Africa, Turkey, United Arab Emirates, United States and Customize locales.</p>
<p><b>Allow Analog Trunk to Trunk Connect</b></p>	<p>Default = Not selected (Off). When not enabled, users cannot transfer or forward external calls back off-switch using an analog trunk if the call was originally made or received on another analog trunk. This prevents transfers to trunks that do not support disconnect clear.</p> <p>If the setting <b>System   Telephony   Telephony   Unsupervised Analog Trunk Disconnect Handling</b> is enabled, this setting is greyed out and trunk to trunk connections to any analog trunks are not allowed.</p>
<p><b>BCC</b></p>	<p>Default = Not selected [Brazil locale only]</p> <p>A collect call is a call at the receiver's expense and by his permission. If supported by the line provider, BCC (Block Collect Call) can be used to bar collect calls.</p>

*Table continues...*

Field	Description
<b>Secondary Dial Tone</b>	<p>Default = Off</p> <p>Configures the use of secondary dial tone on analog lines. This is a different mechanism from secondary dial tone using short codes. This method is used mainly within the Russian locale. When selected, the options are:</p> <ul style="list-style-type: none"> <li>• <b>Await time:</b> Default = 3000ms. Range = 0 to 25500ms. Used when secondary dial tone (above) is selected. Sets the delay.</li> <li>• <b>After n Digits:</b> Default = 1. Range = 0 to 10. Sets where in the dialing string, the delay for secondary dial tone, should occur.</li> <li>• <b>Matching Digit:</b> Default =8. Range = 0 to 9. The digit which, when first matched in the dialing string, will cause secondary dial tone delay.</li> </ul>
<b>Long CLI Line</b>	<p>Default = Off</p> <p>The CLI signal on some analog lines can become degraded and is not then correctly detected. If you are sure that CLI is being provided but not detected, selecting this option may resolve the problem.</p>
<b>Modem Enabled</b>	<p>Default = Off</p> <p>The first analog trunk in a control unit can be set to modem operation (V32 with V42 error correction). This allows the trunk to answer incoming modem calls and be used for system maintenance. When on, the trunk can only be used for analog modem calls. The default system short code *9000* can be used to toggle this setting.</p> <p>For the IP500 ATM4U-V2 Trunk Card Modem, it is not required to switch the card's modem port on/off. The trunk card's V32 modem function can be accessed simply by routing a modem call to the RAS service's extension number. The modem call does not have to use the first analog trunk, instead the port remains available for voice calls.</p>
<b>MWI Standard</b>	<p>Default = None.</p> <p>This setting is only displayed for ATM4U-V2 cards.</p> <p>When <b>System   Voicemail   Voicemail Type</b> is set to <b>Analogue MWI</b>, change this setting to <b>Bellcore FSKBellcore FSK</b>.</p>
<b>Pulse Dialing</b>	<p>These settings are used for pulse dialing.</p> <ul style="list-style-type: none"> <li>• <b>Mark:</b> Default = 40ms. Range = 0 to 255. Interval when DTMF signal is kept active during transmission of DTMF signals.</li> <li>• <b>Space:</b> Default = 60ms. Range = 0 to 255. Interval of silence between DTMF signal transmissions.</li> <li>• <b>Inter-Digit Pause:</b> Default = 500ms. Range = 0 to 2550ms. Sets the pause between digits transmitted to the line.</li> </ul>

*Table continues...*

Field	Description
<b>Ring Detection</b>	<p>These settings are used for ring detection.</p> <ul style="list-style-type: none"> <li>• <b>Ring Persistency:</b> Default = Set according to system locale. Range = 0 to 2550ms. The minimum duration of signal required to be recognized.</li> <li>• <b>Ring Off Maximum:</b> Default = Set according to system locale. Range = 0 to 25500ms. The time required before signaling is regarded as ended.</li> </ul>
<b>Disconnect Clear</b>	<p>Disconnect clear (also known as 'Line Break' or 'Reliable Disconnect') is a method used to signal from the line provider that the call has cleared. The system also uses 'Tone Disconnect', which clears an analog call after 6 seconds of continuous tone, configured through the Busy Tone Detection (<b>System   Telephony   Tones &amp; Music</b>) settings.</p> <ul style="list-style-type: none"> <li>• <b>Enable:</b> Default = On Enables the use of disconnect clear.</li> <li>• <b>Units:</b> Default = 500ms. Range = 0 to 2550ms. This time must be less than the actual disconnect time period used by the line provider by at least 150ms.</li> </ul> <p>If the setting <b>System   Telephony   Telephony   Unsupervised Analog Trunk Disconnect Handling</b> is enabled, this setting is greyed out and disconnect clear disabled.</p>
<b>DTMF</b>	<p>These settings are used for DTMF dialing.</p> <ul style="list-style-type: none"> <li>• <b>On:</b> Default = 80ms. Range = 0 to 255ms. The width of the on pulses generated during DTMF dialing.</li> <li>• <b>Off:</b> Default = 80ms. Range = 0 to 255ms. The width of the off pulses generated during DTMF dialing.</li> </ul>
<b>BCC Flash Pulse Width</b>	<p>[Brazil locale only] Default = 100 (1000ms). Range = 0 to 255. Sets the BCC (Block collect call) flash pulse width.</p>
<b>Gains</b>	<p>These settings are used to adjust the perceived volume on all calls.</p> <ul style="list-style-type: none"> <li>• <b>A   D:</b> Default = 0dB. Range = -10.0dB to +6.0dB in 0.5dB steps. Sets the analog to digital gain applied to the signal received from the trunk by the system. To conform with the Receive Objective Loudness Rating at distances greater than 2.7km from the central office, on analog trunks a receive gain of 1.5dB must be set.</li> <li>• <b>D   A:</b> Default = 0dB. Range = -10.0dB to +6.0dB in 0.5dB steps. Sets the digital to analog gain applied to the signal from the system to the trunk.</li> <li>• <b>Voice Recording:</b> Default = Low Used to adjust the volume level of calls recorded by voicemail. The options are: <ul style="list-style-type: none"> <li>- <b>Low</b></li> <li>- <b>Medium</b></li> <li>- <b>High</b></li> </ul> </li> </ul>

**Related links**

[Analog Line](#) on page 280



---

## BRI Line

BRI trunks are provided by the installation of a BRI trunk card into the control unit. The cards are available in different variants with either 2 or 4 physical ports. Each port supports 2 B-channels for calls. For full details of installation refer to the IP Office Installation manual.

### Point-to-Point or Multipoint

BRI lines can be used in either Point-to-Point or Point-to-Multipoint mode. Point-to-Point lines are used when only one device terminates a line in a customer's office. Point-to-Multipoint lines are used when more than one device may be used on the line at the customer's premises. There are major benefits in using Point-to-Point lines:-

- The exchange knows when the line/terminal equipment is down/dead, thus it will not offer calls down that line. If the lines are Point-to-Multipoint, calls are always offered down the line and fail if there is no response from the terminal equipment. So if you have two Point-to-Multipoint lines and one is faulty 50% of incoming calls fail.
- You get a green LED on the Control Unit when the line is connected. With Point-to-Multipoint lines some exchanges will drop layer 1/2 signals when the line is idle for a period.
- The timing clock is locked to the exchange. If layer 1/2 signals disappear on a line then the Control Unit will switch to another line, however this may result in some audible click when the switchover occurs.

The system's default Terminal Equipment Identifier (TEI) will normally allow it to work on Point-to-Point or Point-to-Multipoint lines. However if you intend to connect multiple devices simultaneously to an BRI line, then the TEI should be set to 127. With a TEI of 127, the control unit will ask the exchange to allocate a TEI for operation.

#### Note:

When connected to some manufactures equipment, which provides an S0 interface (BRI), a defaulted Control Unit will not bring up the ISDN line. Configuring the Control Unit to a TEI of 127 for that line will usually resolve this.

#### Related links

[Line](#) on page 279

[BRI Line](#) on page 289

[Channels](#) on page 294

## BRI Line

Navigation: [Line](#) | **BRI Line**

The following settings are not mergeable. Changes to these settings will require a reboot of the system.

- **Line Sub Type**
- **Network Type**
- **TEI**

- **Add 'Not-end-to-end ISDN' Information Element**
- **Progress Replacement**
- **Clock Quality**
- **Force Number Plan to ISDN**

Decreasing the **Number of Channels** setting requires a a “merge with service disruption”. When the configuration file is sent to the system, active calls on the deleted channels are cleared.

The remaining settings are mergeable.

Field	Description
<b>Card/Module</b>	Indicates the card slot or expansion module being used for the trunk device providing the line.  For IP500 V2 control units: 1 to 4 match the slots on the front of the control unit from left to right. Expansion modules are numbered from 5 upwards, for example trunks on the module in Expansion Port 1 are shown as 5.
<b>Port</b>	Indicates the port on the Card/Module above to which the configuration settings relate.
<b>Line Number</b>	This parameter is not configurable; it is allocated by the system.
<b>Admin</b>	Default = In Service.  This field allows a trunk to be taken out of service if required for maintenance or if the trunk is not connected.
<b>Line Sub Type</b>	Default = <b>NTT</b> for Japan/ <b>ETSI</b> for other locales.  Select to match the particular line type provided by the line provider. IP500 BRI daughter cards can be configured for <b>S-Bus</b> (So) operation for connection to ISDN terminal devices. Note that this requires the addition of terminating resistors at both the system and remote ends, and the use of a suitable cross-over cable. For full details refer to the Deploying Avaya IP Office Platform IP500 V2 manual.
<b>Network Type</b>	Default = Public.  This option is available if <b>System   Telephony   Telephony   Restrict Network Interconnect</b> is enabled. It allows the trunk to be set as either <b>Public</b> or <b>Private</b> . The system will return number busy indication to any attempt to connect a call on a <b>Private</b> trunk to a <b>Public</b> trunk or vice versa. This restriction includes transfers, forwarding and conference calls.  Due to the nature of this feature, its use is not recommended on systems also using any of the following other system features: multi-site networks, VPNremote, application telecommuter mode.
<b>Telephone Number</b>	Used to remember the external telephone number of this line to assist with loop-back testing. For information only.
<b>Incoming Group ID</b>	Default = 0, Range 0 to 99999.  The Incoming Group ID to which a line belongs is used to match it to incoming call routes in the system configuration. The matching incoming call route is then used to route incoming calls. The same ID can be used for multiple lines.

*Table continues...*

Field	Description
<b>Outgoing Group ID</b>	<p>Default = 1. Range 0 to 99999.</p> <p>Short codes that specify a number to dial can specify the line group to be used. The system will then seize a line from those available with a matching Outgoing Group ID.</p> <p>In a Server Edition/Select network, the <b>Outgoing Group ID</b> used for lines to a system must be unique within the network. The same ID cannot be used in the configuration of any lines to another server system in the network.</p> <p><b>Reserved Group ID Numbers:</b></p> <ul style="list-style-type: none"> <li>• <b>90000 - 99999</b> Reserved for system use (not enforced).</li> <li>• <b>99999 and 99998</b> In a Server Edition/Select network, reserved for the IP Office lines to the primary and secondary server respectively.</li> <li>• <b>99001 to 99148</b> In a Server Edition/Select network, reserved for the IP Office lines from the primary and secondary servers to each expansion system in the network.</li> <li>• <b>0</b> In a Server Edition/Select network, the ID 0 cannot be used.</li> <li>• <b>98888</b> For IP Office deployed in an Enterprise Branch environment, reserved for the SM line.</li> </ul>
<b>Prefix</b>	<p>Default = Blank. The prefix is used in the following ways:</p> <ul style="list-style-type: none"> <li>• <b>For incoming calls:</b> The ISDN messaging tags indicates the call type (National, International or Unknown). If the call type is unknown, then the number in the Prefix field is added to the ICLID.</li> <li>• <b>For outgoing calls:</b> The prefix is not stripped, therefore any prefixes not suitable for external line presentation should be stripped using short codes.</li> </ul>
<b>National Prefix</b>	<p>Default = 0</p> <p>This indicates the digits to be prefixed to a incoming national call. When a number is presented from ISDN as a "national number" this prefix is added. For example 1923000000 is converted to 01923000000.</p>
<b>International Prefix</b>	<p>Default = 00</p> <p>This indicates the digits to be prefixed to an incoming international call. When a number is presented from ISDN as an "international number" this prefix is added. For example 441923000000 is converted to 00441923000000.</p>
<b>TEI</b>	<p>Default = 0 The Terminal Equipment Identifier. Used to identify each device connected to a particular ISDN line. For Point-to-Point lines this is 0. It can also be 0 on a Point to Multipoint line, however if multiple devices are sharing a Point-to-Multipoint line it should be set to 127 which results in the exchange allocating the TEI's to be used.</p>
<b>Number of Channels</b>	<p>Default = 2. Range = 0 to 2.</p> <p>Defines the number of operational channels that are available on this line.</p>

*Table continues...*

Field	Description
<b>Outgoing Channels</b>	<p>Default = 2. Range = 0 to 2.</p> <p>This defines the number of channels available, on this line, for outgoing calls. This should normally be the same as Number of Channels field, but can be reduced to ensure incoming calls cannot be blocked by outgoing calls.</p>
<b>Voice Channels</b>	<p>Default = 2. Range = 0 to 2.</p> <p>The number of channels available for voice use.</p>
<b>Data Channels</b>	<p>Default = 2. Range = 0 to 2.</p> <p>The number of channels available for data use. If left blank, the value is 0.</p>
<b>Clock Quality</b>	<p>Default = Network</p> <p>Refer to the IP Office Installation Manual for full details. This option sets whether the system should try to take its clock source for call synchronization and signalling from this line. Preference should always be given to using the clock source from a central office exchange if available by setting at least one exchange line to <b>Network</b>.</p> <ul style="list-style-type: none"> <li>• If multiple lines are set as <b>Network</b>, the order in which those lines are used is described in the IP Office Installation Manual. If additional lines are available, <b>Fallback</b> can be used to specify a clock source to use should the <b>Network</b> source not be available.</li> <li>• Lines from which the clock source should not be taken should be set as <b>Unsuitable</b>.</li> <li>• If no clock source is available, the system uses its own internal 8KHz clock source.</li> <li>• In scenarios where several systems are network via digital trunk lines, care must be taken to ensure that all the systems use the same clock source. The current source being used by a system is reported within the System Status Application.</li> </ul>
<b>Add 'Not-end-to-end ISDN' Information Element</b>	<p>Default = Never*. Sets whether the optional 'Not end-to-end ISDN' information element should be added to outgoing calls on the line. The options are <b>Never</b>, <b>Always</b> or <b>POTS</b> (only if the call was originated by an analog extension). *The default is <b>Never</b> except for the following locales; for Italy the default is <b>POTS</b>, for New Zealand the default is <b>Always</b>.</p>

*Table continues...*

Field	Description
<b>Progress Replacement</b>	<p>Default = None.</p> <p>Progress messages are defined in the Q.931 ISDN connection control signaling protocol. Generally, if a progress message is sent, the caller does not get connected and so typically does not accrue call costs.</p> <p>Not all ISDN lines support Q.931 Progress messages. Use this setting to configure alternative signaling to the ISDN line for internally generated Progress messages. The options are:</p> <ul style="list-style-type: none"> <li>• <b>Alerting:</b> Map to Q.931 Alerting. The call is not connected. The caller does not hear the message and typically does not accrue call costs.</li> <li>• <b>Connect:</b> Map to Q.931 Connect. The caller hears the message and typically will accrue call costs.</li> </ul>
<b>Supports Partial Rerouting</b>	<p>Default = Off.</p> <p>Partial rerouting (PR) is an ISDN feature. It is supported on external (non-network and QSIG) ISDN exchange calls. When an external call is transferred to another external number, the transfer is performed by the ISDN exchange and the channels to the system are freed. Use of this service may need to be requested from the line provider and may incur a charge.</p>
<b>Force Number Plan to ISDN</b>	<p>Default = Off.</p> <p>This option is only configurable when <b>Support Partial Rerouting</b> is also enabled. When selected, the plan/type parameter for Partial Rerouting is changed from <b>Unknown/Unknown</b> to <b>ISDN/Unknown</b>.</p>
<b>Send Redirecting Number</b>	<p>Default = Off.</p> <p>This option can be used on ISDN trunks where the redirecting service is supported by the trunk provider. Where supported, on twinned calls the caller ID of the original call is passed through to the twinning destination. This option is only used for twinned calls.</p>
<b>Support Call Tracing</b>	<p>Default = Off. The system supports the triggering of malicious caller ID (MCID) tracing at the ISDN exchange. Use of this feature requires liaison with the ISDN service provider and the appropriate legal authorities to whom the call trace will be passed. The user will also need to be enabled for call tracing and be provider with either a short code or programmable button to activate MCID call trace. Refer to Malicious Call Tracing in the Telephone Features section for full details.</p>
<b>Active CCBS Support</b>	<p>Default = Off.</p> <p>Call completion to a busy subscriber (CCBS). It allows automatic callback to be used on outgoing ISDN calls when the destination is busy. This feature can only be used on point-to-point trunks. Use of this service may need to be requested from the line provider and may incur a charge.</p>
<b>Passive CCBS</b>	<p>Default = Off.</p>

*Table continues...*

Field	Description
<b>Cost Per Charging Unit</b>	The information is provided in the form of charge units. This setting is used to enter the call cost per charging unit set by the line provider. The values are 1/10,000th of a currency unit. For example if the call cost per unit is £1.07, a value of 10700 should be set on the line. Refer to Advice of Charge.
<b>Send original calling party for forwarded and twinning calls</b>	Default = Off. Use the original calling party ID when forwarding calls or routing twinned calls. This setting applies to BRI lines with subtype ETSI.
<b>Originator number for forwarded and twinning calls</b>	Default = blank. The number used as the calling party ID when forwarding calls or routing twinned calls. This field is grayed out when the <b>Send original calling party for forwarded and twinning calls</b> setting is enabled. This setting applies to BRI lines with subtype ETSI.

**Related links**

[BRI Line](#) on page 289

## Channels

Navigation: **Line | BRI Line | Channels**

This tab allows settings for individual channels within the trunk to be adjusted. To edit a channel either double-click on it or click the channel and then select **Edit**.

To edit multiple channels at the same time, select the required channels using Ctrl or Shift and then click **Edit**. When editing multiple channels, fields that must be unique such as **Line Appearance ID** are not shown.

These settings are mergeable. Changes to these settings do not require a system reboot.

Field	Description
<b>Line Appearance ID</b>	Default = Auto-assigned. Range = 2 to 9 digits. Used for configuring Line Appearances with button programming. The line appearance ID must be unique and not match any extension number. Line appearance is not supported for trunks set to QSIG operation and is not recommended for trunks be used for DID.

**Related links**

[BRI Line](#) on page 289

## PRI Trunks

PRI trunks are provided by the installation of a PRI trunk card into the control unit. avThe IP500 PRI-U trunk card can be configured (see below) to one of those line types. The cards are also available with either 1 or 2 physical ports. The number of B-channels supported by each physical port depends on the line type of the card.

- **E1**: 30 B-channels and 1 D-channel per port.

- **T1**: 24 B-channels per port.
- **US PRI**: 23 B-channels and 1 D-channel per port.
- **E1-R2**: 30 B-channels and 1 D-channel per port.

### IP500 PRI-U Trunk Card Line Type

The IP500 PRI-U card can be configured to support either E1, T1 or E1-R2 PRI line types. To select the line type required, right-click on the line in the group or navigation pane and select **Change Universal PRI Card Line Type**.

The control unit supports 8 B-channels on each IP500 PRI-U card fitted. Additional B-channels up to the full capacity of IP500 PRI-U ports installed require licenses added to the configuration. D-channels are not affected by licensing.

For ETSI and QSIG trunks, license instances are consumed by the number of calls in progress on B-channels.

For T1, E1R2 and ETSI CHI trunks, licenses instances are consumed by the channels set as in service.

#### Related links

- [Line](#) on page 279
- [E1 Line](#) on page 295
- [E1 R2 Line](#) on page 304
- [T1 Line](#) on page 310
- [T1 PRI Line](#) on page 315

## E1 Line

#### Related links

- [PRI Trunks](#) on page 294
- [E1 PRI Line](#) on page 295
- [E1 Short Codes](#) on page 302
- [E1 PRI Channels](#) on page 302

### E1 PRI Line

Navigation: [Line](#) | **E1 PRI Line**

The following settings are not mergeable. Changes to these settings require a system reboot.

- **Line Sub Type**
- **Network Type**
- **TEI**
- **Channel Allocation**
- **CRC Checking**
- **Clock Quality**
- **Add 'Not-end-to-end ISDN' Information Element**
- **Progress Replacement**

- **Force Number Plan to ISDN**
- **Line Signalling**

Decreasing the **Number of Channels** setting requires a a “merge with service disruption”. When the configuration file is sent to the system, active calls on the deleted channels are cleared.

The remaining settings are mergeable.

Field	Description
<b>Line Number</b>	This parameter is not configurable; it is allocated by the system.
<b>Line Sub Type</b>	Select to match the particular line type provided by the line provider. The options are: <ul style="list-style-type: none"> <li>• <b>ETSI</b></li> <li>• <b>ETSI CHI</b></li> <li>• <b>QSIG A</b></li> <li>• <b>QSIG B</b></li> </ul> <p><b>ETSI CHI</b> is used to send the channel allocation ID (CHI) in the call setup signalling. This is a request to use a particular B-channel rather than use any B-channel allocated by the central office exchange.</p> <p>QSIG trunks are not supported on IP500 V2 systems without IP500 Voice Networking licenses.</p>
<b>Card/Module</b>	Indicates the card slot or expansion module being used for the trunk device providing the line. <p>For IP500 V2 control units: 1 to 4 match the slots on the front of the control unit from left to right. Expansion modules are numbered from 5 upwards, for example trunks on the module in Expansion Port 1 are shown as 5.</p>
<b>Port</b>	Indicates the port on the Card/Module above to which the configuration settings relate.
<b>Network Type</b>	Default = Public. <p>This option is available if <b>System   Telephony   Telephony   Restrict Network Interconnect</b> is enabled. It allows the trunk to be set as either <b>Public</b> or <b>Private</b>. The system will return number busy indication to any attempt to connect a call on a <b>Private</b> trunk to a <b>Public</b> trunk or vice versa. This restriction includes transfers, forwarding and conference calls.</p> <p>Due to the nature of this feature, its use is not recommended on systems also using any of the following other system features: multi-site networks, VPNremote, application telecommuter mode.</p>
<b>Telephone Number</b>	Used to remember the external telephone number of this line to assist with loop-back testing. For information only.

*Table continues...*



Field	Description
<b>Channel Allocation</b>	<p>Default = 30 1.</p> <p>For lines set to <b>ETSI CHI</b>, this option allows the system to select the default order in which channels should be used for outgoing calls. Typically this is set as the opposite of the default order in which the central office exchange uses channels for incoming calls.</p> <p>For lines set to the <b>Line Sub Type</b> of <b>ETSI CHI</b>, the <b>Incoming Group ID</b> is set as part of the individual channel settings.</p>
<b>Incoming Group ID</b>	<p>Default = 0, Range 0 to 99999.</p> <p>The Incoming Group ID to which a line belongs is used to match it to incoming call routes in the system configuration. The matching incoming call route is then used to route incoming calls. The same ID can be used for multiple lines.</p>
<b>Outgoing Group ID</b>	<p>Default = 1. Range 0 to 99999.</p> <p>Short codes that specify a number to dial can specify the line group to be used. The system will then seize a line from those available with a matching Outgoing Group ID.</p> <p>In a Server Edition/Select network, the <b>Outgoing Group ID</b> used for lines to a system must be unique within the network. The same ID cannot be used in the configuration of any lines to another server system in the network.</p> <p><b>Reserved Group ID Numbers:</b></p> <ul style="list-style-type: none"> <li>• <b>90000 - 99999</b> Reserved for system use (not enforced).</li> <li>• <b>99999 and 99998</b> In a Server Edition/Select network, reserved for the IP Office lines to the primary and secondary server respectively.</li> <li>• <b>99001 to 99148</b> In a Server Edition/Select network, reserved for the IP Office lines from the primary and secondary servers to each expansion system in the network.</li> <li>• <b>0</b> In a Server Edition/Select network, the ID 0 cannot be used.</li> <li>• <b>98888</b> For IP Office deployed in an Enterprise Branch environment, reserved for the SM line.</li> </ul>
<b>Prefix</b>	<p>Default = Blank.</p> <p>The prefix is used in the following ways:</p> <ul style="list-style-type: none"> <li>• <b>For incoming calls</b> The ISDN messaging tags indicates the call type (National, International or Unknown). If the call type is unknown, then the number in the Prefix field is added to the ICLID.</li> <li>• <b>For outgoing calls</b> The prefix is not stripped, therefore any prefixes not suitable for external line presentation should be stripped using short codes.</li> </ul>
<b>National Prefix</b>	<p>Default = 0</p> <p>This indicates the digits to be prefixed to a incoming national call. When a number is presented from ISDN as a "national number" this prefix is added. For example 1923000000 is converted to 01923000000.</p>

*Table continues...*

Field	Description
<b>International Prefix</b>	<p>Default = 00</p> <p>This indicates the digits to be prefixed to an incoming international call. When a number is presented from ISDN as an "international number" this prefix is added. For example 441923000000 is converted to 00441923000000.</p>
<b>TEI</b>	<p>Default = 0 The</p> <p>Terminal Equipment Identifier. Used to identify each Control Unit connected to a particular ISDN line. For Point to Point lines this is typically (always) 0. It can also be 0 on a Point to Multi-Point line, however if multiple devices are sharing a Point to Multi-Point line it should be set to 127 which results in the exchange deciding on the TEI's to be used.</p>
<b>Number of Channels</b>	<p>Defines the number of operational channels that are available on this line. Up to 30 for E1 PRI, 23 for T1 PRI.</p>
<b>Outgoing Channels</b>	<p>This defines the number of channels available, on this line, for outgoing calls. This should normally be the same as <b>Number of Channels</b> field, but can be reduced to ensure incoming calls cannot be blocked by outgoing calls. Only available when the <b>Line Sub Type</b> is set to <b>ETSI</b>.</p>
<b>Voice Channels</b>	<p>The number of channels available for voice use. Only available when the <b>Line Sub Type</b> is set to <b>ETSI</b>.</p>
<b>Data Channels</b>	<p>The number of channels available for data use. Only available when the <b>Line Sub Type</b> is set to <b>ETSI</b>.</p>
<b>CRC Checking</b>	<p>Default = On</p> <p>Switches CRC on or off.</p>
<b>Line Signalling</b>	<p>Default = CPE This option is not used for lines where the <b>Line SubType</b> is set to <b>QSIG</b>. Select either <b>CPE</b> (customer premises equipment) or <b>CO</b> (central office). The <b>CO</b> feature is intended to be used primarily as a testing aid. It allows PRI lines to be tested in a back-to-back configuration, using crossover cables.</p> <p>The CO feature operates on this line type by modifying the way in which incoming calls are disconnected for system configuration in Brazil and Argentina. In these locales, the CO setting uses Forced-Release instead of Clear-Back to disconnect incoming calls. The Brazilian Double-Seizure mechanism, used to police Collect calls, is also disabled in CO mode.</p>

*Table continues...*

Field	Description
<b>Clock Quality</b>	<p>Default = Network</p> <p>Refer to the IP Office Installation Manual for full details. This option sets whether the system should try to take its clock source for call synchronization and signalling from this line. Preference should always be given to using the clock source from a central office exchange if available by setting at least one exchange line to <b>Network</b>.</p> <ul style="list-style-type: none"> <li>• If multiple lines are set as <b>Network</b>, the order in which those lines are used is described in the IP Office Installation Manual. If additional lines are available, <b>Fallback</b> can be used to specify a clock source to use should the <b>Network</b> source not be available.</li> <li>• Lines from which the clock source should not be taken should be set as <b>Unsuitable</b>.</li> <li>• If no clock source is available, the system uses its own internal 8KHz clock source.</li> <li>• In scenarios where several systems are network via digital trunk lines, care must be taken to ensure that all the systems use the same clock source. The current source being used by a system is reported within the System Status Application.</li> </ul>
<b>Add 'Not-end-to-end ISDN' Information Element</b>	<p>Default = Never</p> <p>Sets whether the optional 'Not end-to-end ISDN' information element should be added to outgoing calls on the line. The options are:</p> <ul style="list-style-type: none"> <li>• <b>Never</b></li> <li>• <b>Always</b></li> <li>• <b>POTS</b>(only if the call was originated by an analog extension).</li> </ul> <p>The default is <b>Never</b> except for the following locales; for Italy the default is <b>POTS</b>, for New Zealand the default is <b>Always</b>.</p>
<b>Progress Replacement</b>	<p>Default = None.</p> <p>Progress messages are defined in the Q.931 ISDN connection control signaling protocol. Generally, If a progress message is sent, the caller does not get connected and so typically does not accrue call costs.</p> <p>Not all ISDN lines support Q.931 Progress messages. Use this setting to configure alternative signaling to the ISDN line for internally generated Progress messages. The options are:</p> <ul style="list-style-type: none"> <li>• <b>Alerting</b>: Map to Q.931 Alerting. The call is not connected. The caller does not hear the message and typically does not accrue call costs.</li> <li>• <b>Connect</b>: Map to Q.931 Connect. The caller hears the message and typically will accrue call costs.</li> </ul>

*Table continues...*

Field	Description
<b>Supports Partial Rerouting</b>	<p>Default = Off.</p> <p>Partial rerouting (PR) is an ISDN feature. It is supported on external (non-network and QSIG) ISDN exchange calls. When an external call is transferred to another external number, the transfer is performed by the ISDN exchange and the channels to the system are freed. Use of this service may need to be requested from the line provider and may incur a charge.</p>
<b>Force Number Plan to ISDN</b>	<p>Default = Off.</p> <p>This option is only configurable when <b>Support Partial Rerouting</b> is also enabled. When selected, the plan/type parameter for Partial Rerouting is changed from <b>Unknown/Unknown</b> to <b>ISDN/Unknown</b>.</p>
<b>Send Redirecting Number</b>	<p>Default = Off.</p> <p>This option can be used on ISDN trunks where the redirecting service is supported by the trunk provider. Where supported, on twinned calls the caller ID of the original call is passed through to the twinning destination. This option is only used for twinned calls.</p>
<b>Support Call Tracing</b>	<p>Default = Off.</p> <p>The system supports the triggering of malicious caller ID (MCID) tracing at the ISDN exchange. Use of this feature requires liaison with the ISDN service provider and the appropriate legal authorities to whom the call trace will be passed. The user will also need to be enabled for call tracing and be provider with either a short code or programmable button to activate MCID call trace. Refer to Malicious Call Tracing in the Telephone Features section for full details.</p>
<b>Active CCBS Support</b>	<p>Default = Off.</p> <p>Call completion to a busy subscriber (CCBS). It allows automatic callback to be used on outgoing ISDN calls when the destination is busy. This feature can only be used on point-to-point trunks. Use of this service may need to be requested from the line provider and may incur a charge.</p>
<b>Passive CCBS</b>	<p>Default = Off.</p>
<b>Cost Per Charging Unit</b>	<p>Advice of charge (AOC) information can be display on T3/T3IP phones and output in SMDR. The information is provided in the form of charge units. This setting is used to enter the call cost per charging unit set by the line provider. The values are 1/10,000th of a currency unit. For example if the call cost per unit is £1.07, a value of 10700 should be set on the line. Refer to Advice of Charge.</p>
<b>Admin</b>	<p>Default = In Service.</p> <p>This field allows a trunk to be taken out of service if required for maintenance or if the trunk is not connected.</p>

*Table continues...*

Field	Description
<b>Send original calling party for forwarded and twinning calls</b>	<p>Default = Off.</p> <p>Use the original calling party ID when forwarding calls or routing twinned calls.</p> <p>This setting applies to the following ISDN lines:</p> <ul style="list-style-type: none"> <li>• PRI24 with subtypes: <ul style="list-style-type: none"> <li>- PRI</li> <li>- QSIGA</li> <li>- QSIGB</li> <li>- ETSI</li> <li>- ETSI CHI</li> </ul> </li> <li>• PRI30 with subtypes <ul style="list-style-type: none"> <li>- QSIGA</li> <li>- QSIGB</li> <li>- ETSI</li> <li>- ETSI CHI</li> </ul> </li> </ul>
<b>Originator number for forwarded and twinning calls</b>	<p>Default = blank.</p> <p>The number used as the calling party ID when forwarding calls or routing twinned calls. This field is grayed out when the <b>Send original calling party for forwarded and twinning calls</b> setting is enabled.</p> <p>This setting applies to the following ISDN lines:</p> <ul style="list-style-type: none"> <li>• PRI24 with subtypes: <ul style="list-style-type: none"> <li>- PRI</li> <li>- QSIGA</li> <li>- QSIGB</li> <li>- ETSI</li> <li>- ETSI CHI</li> </ul> </li> <li>• PRI30 with subtypes <ul style="list-style-type: none"> <li>- QSIGA</li> <li>- QSIGB</li> <li>- ETSI</li> <li>- ETSI CHI</li> </ul> </li> </ul>

The following fields are shown for a US T1 trunk card set to ETSI or QSIG operation. These cards have the same settings E1 PRI trunk cards set to ETSI or QSIG but only support 23 channels.

These settings are not mergeable. Changing these settings requires a system reboot.

Field	Description
<b>CSU Operation</b>	Check this field to enable the T1 line to respond to loop-back requests from the line.
<b>Haul Length</b>	Default = 0-115 feet Sets the line length to a specific distance.
<b>Channel Unit</b>	Default = Foreign Exchange This field should be set to match the channel signaling equipment provided by the Central Office. The options are Foreign Exchange, Special Access or Normal.

**Related links**

[E1 Line](#) on page 295

**E1 Short Codes**

Navigation: **Line | E1 Short Codes**

For some types of line, Line short codes can be applied to any digits received with incoming calls.

The line Short Code tab is shown for the following trunk types which are treated as internal or private trunks: **QSIG** (T1, E1, H.323), **BRI S0**, **H.323**, **SCN**, **IP Office**. Incoming calls on those types of trunk are not routed using **Incoming Call Route** settings. Instead the digits received with incoming calls are checked for a match as follows:

Extension number (including remote numbers in a multi-site network).

- Line short codes (excluding ? short code).
- System short codes (excluding ? short code).
- Line ? short code.
- System ? short code.

Short codes can be added and edited using the **Add**, **Remove** and **Edit** buttons. Alternatively you can right-click on the list of existing short code to add and edit short codes.

Changes to these settings do not require a reboot of the system.

**Related links**

[E1 Line](#) on page 295

**E1 PRI Channels**

Navigation: **Line | E1 PRI Channels**

This tab allows settings for individual channels within the trunk to be adjusted. To edit a channel either double-click on it or click the channel and then select **Edit**.

To edit multiple channels at the same time, select the required channels using Ctrl or Shift and then click **Edit**. When editing multiple channels, fields that must be unique such as **Line Appearance ID** are not shown.

The following settings are mergeable:

- **Line Appearance ID** (ETSI, ETSI CHI)
- **Admin** (ETSI CHI)

- **Incoming Group ID** (ETSI CHI)
- **Outgoing Group ID** (ETSI CHI)

The remaining settings are not mergeable. Changes to these settings require a system reboot.

Field	Description
<b>Line Appearance ID</b>	<p>Default = Auto-assigned. Range = 2 to 9 digits.</p> <p>Used for configuring Line Appearances with button programming. The line appearance ID must be unique and not match any extension number. Line appearance is not supported for trunks set to QSIG operation and is not recommended for trunks be used for DID.</p> <p>If the trunk <b>Line Sub Type</b> is set to <b>ETSI CHI</b>, outgoing line appearance calls must use the corresponding channel.</p>

The following additional fields are shown for lines where the **Line Sub Type** is set to **ETSI CHI**.

Field	Description
<b>Incoming Group ID</b>	<p>Default = 0, Range 0 to 99999. The Incoming Group ID to which a line belongs is used to match it to incoming call routes in the system configuration. The matching incoming call route is then used to route incoming calls. The same ID can be used for multiple lines.</p>
<b>Outgoing Group ID</b>	<p>Default = 1. Range 0 to 99999.</p> <p>Short codes that specify a number to dial can specify the line group to be used. The system will then seize a line from those available with a matching Outgoing Group ID.</p> <p>In a Server Edition/Select network, the <b>Outgoing Group ID</b> used for lines to a system must be unique within the network. The same ID cannot be used in the configuration of any lines to another server system in the network.</p> <p><b>Reserved Group ID Numbers:</b></p> <ul style="list-style-type: none"> <li>• <b>90000 - 99999</b> Reserved for system use (not enforced).</li> <li>• <b>99999 and 99998</b> In a Server Edition/Select network, reserved for the IP Office lines to the primary and secondary server respectively.</li> <li>• <b>99001 to 99148</b> In a Server Edition/Select network, reserved for the IP Office lines from the primary and secondary servers to each expansion system in the network.</li> <li>• <b>0</b> In a Server Edition/Select network, the ID 0 cannot be used.</li> <li>• <b>98888</b> For IP Office deployed in an Enterprise Branch environment, reserved for the SM line.</li> </ul>

*Table continues...*

Field	Description
<b>Direction</b>	Default = Bothways The direction of calls on the channel. The options are: <ul style="list-style-type: none"> <li>• <b>Incoming</b></li> <li>• <b>Outgoing</b></li> <li>• <b>Bothways</b></li> </ul>
<b>Bearer</b>	Default = Any The type of traffic carried by the channel. The options are: <ul style="list-style-type: none"> <li>• <b>Voice</b></li> <li>• <b>Data</b></li> <li>• <b>Any</b></li> </ul>
<b>Admin</b>	Default = Out of Service. This field can be used to indicate whether the channel is in use or not. On trunks where only a limited number of channels have been requested from the trunk provider (known as sub-equipped trunks), those channels not provided should be set as <b>Out of Service</b> . For channels that are available but are temporarily not being used select <b>Maintenance</b> .
<b>Tx Gain</b>	Default = 0dB. Range = -10dBb to +5dB. The transmit gain in dB.
<b>Rx Gain</b>	Default = 0dB. Range = -10dBb to +5dB. The receive gain in dB.

**Related links**

[E1 Line](#) on page 295

**E1 R2 Line**

Navigation: [Line](#) | [E1–R2 Line](#)

**Related links**

[PRI Trunks](#) on page 294

[E1-R2 Options](#) on page 304

[E1-R2 Channels](#) on page 306

[E1 R2 MFC Group](#) on page 308

[E1-R2 Advanced](#) on page 308

**E1-R2 Options**

Navigation: [Line](#) | [E1–R2 Options](#)

Changing the **Admin** setting is mergeable. The remaining settings are not mergeable. Changes to these settings will require a reboot of the system.



Field	Description
<b>Card/Module</b>	<p>Indicates the card slot or expansion module being used for the trunk device providing the line.</p> <p>For IP500 V2 control units: 1 to 4 match the slots on the front of the control unit from left to right. Expansion modules are numbered from 5 upwards, for example trunks on the module in Expansion Port 1 are shown as 5.</p>
<b>Port</b>	Indicates the port on the Card/Module above to which the configuration settings relate.
<b>Network Type</b>	<p>Default = Public.</p> <p>This option is available if <b>System   Telephony   Telephony   Restrict Network Interconnect</b> is enabled. It allows the trunk to be set as either <b>Public</b> or <b>Private</b>. The system will return number busy indication to any attempt to connect a call on a <b>Private</b> trunk to a <b>Public</b> trunk or vice versa. This restriction includes transfers, forwarding and conference calls.</p> <p>Due to the nature of this feature, its use is not recommended on systems also using any of the following other system features: multi-site networks, VPNremote, application telecommuter mode.</p>
<b>Line Number</b>	Allocated by the system.
<b>Line SubType</b>	<p>Default = E1-R2</p> <p>The options are:</p> <ul style="list-style-type: none"> <li>• <b>E1-R2</b></li> <li>• <b>ETSI</b></li> <li>• <b>QSIGA</b></li> <li>• <b>QSIGB</b></li> </ul> <p>QSIG trunks are not supported on IP500 V2 systems without IP500 Voice Networking licenses.</p>
<b>Channel Allocation</b>	<p>Default = 30   1</p> <p>The order, <b>30   1</b> or <b>1   30</b>, in which channels are used.</p>
<b>Country (Locale)</b>	<p>Default = Mexico. Select the locale that matches the area of usage. Note that changing the locale will return the MFC Group settings to the defaults for the selected locale. Currently supported locales are:</p> <ul style="list-style-type: none"> <li>• <b>Argentina</b></li> <li>• <b>Brazil</b></li> <li>• <b>China</b></li> <li>• <b>India</b></li> <li>• <b>Korea</b></li> <li>• <b>Mexico</b></li> <li>• <b>None</b></li> </ul>

*Table continues...*

Field	Description
<b>Admin</b>	<p>Default = In Service.</p> <p>This field allows a trunk to be taken out of service if required for maintenance or if the trunk is not connected.</p> <p>The table at the base of the form displays the settings for the individual channels provided by the line. For details of the channel settings see the E1-R2 Channel form.</p> <p>To edit a channel, either double-click on it or right-click and select <b>Edit</b>. This will display the Edit Channel dialog box. To edit multiple channels at the same time select the channels whilst pressing the Shift or Ctrl key. Then right-click and select <b>Edit</b>.</p>

**Related links**

[E1 R2 Line](#) on page 304

**E1-R2 Channels**

Navigation: **Line | E1–R2 Channels**

The channel settings are split into two sub-tabs, **E1R2 Edit Channel** and **Timers**.

The **Timers** tab displays the various timers provided for E1-R2 channels. These should only be adjusted when required to match the line provider's settings.

This tab allows settings for individual channels within the trunk to be adjusted. To edit a channel, select the required channel or channels and click **Edit**.

The following settings are mergeable:

- **Incoming Group ID**
- **Outgoing Group ID**
- **Admin**

The remaining settings are not mergeable. Changes to these settings require a system reboot.

Field	Descriptions
<b>Channel</b>	The channel or channels being edited.
<b>Incoming Group ID</b>	<p>Default = 0, Range 0 to 99999.</p> <p>The Incoming Group ID to which a line belongs is used to match it to incoming call routes in the system configuration. The matching incoming call route is then used to route incoming calls. The same ID can be used for multiple lines.</p>

*Table continues...*

Field	Descriptions
<b>Outgoing Group ID</b>	<p>Default = 1. Range 0 to 99999.</p> <p>Short codes that specify a number to dial can specify the line group to be used. The system will then seize a line from those available with a matching Outgoing Group ID.</p> <p>In a Server Edition/Select network, the <b>Outgoing Group ID</b> used for lines to a system must be unique within the network. The same ID cannot be used in the configuration of any lines to another server system in the network.</p> <p><b>Reserved Group ID Numbers:</b></p> <ul style="list-style-type: none"> <li>• <b>90000 - 99999</b> Reserved for system use (not enforced).</li> <li>• <b>99999 and 99998</b> In a Server Edition/Select network, reserved for the IP Office lines to the primary and secondary server respectively.</li> <li>• <b>99001 to 99148</b> In a Server Edition/Select network, reserved for the IP Office lines from the primary and secondary servers to each expansion system in the network.</li> <li>• <b>0</b> In a Server Edition/Select network, the ID 0 cannot be used.</li> <li>• <b>98888</b> For IP Office deployed in an Enterprise Branch environment, reserved for the SM line.</li> </ul>
<b>Direction</b>	<p>Default = Both Directions</p> <p>The direction of calls on the channel. The options are:</p> <ul style="list-style-type: none"> <li>• <b>Incoming</b></li> <li>• <b>Outgoing</b></li> <li>• <b>Both Directions</b></li> </ul>
<b>Bearer</b>	<p>Default = Any</p> <p>The type of traffic carried by the channel. The options are:</p> <ul style="list-style-type: none"> <li>• <b>Voice</b></li> <li>• <b>Data</b></li> <li>• <b>Any</b></li> </ul>
<b>Admin</b>	<p>Default = Out of Service.</p> <p>This field can be used to indicate whether the channel is in use or not. On trunks where only a limited number of channels have been requested from the trunk provider (known as sub-equipped trunks), those channels not provided should be set as <b>Out of Service</b>. For channels that are available but are temporarily not being used select <b>Maintenance</b>.</p>

*Table continues...*

Field	Descriptions
<b>Line Signaling Type</b>	<p>Default = R2 Loop Start</p> <p>The signaling type used by the channel. Current supported options are:</p> <ul style="list-style-type: none"> <li>• <b>R2 Loop Start</b></li> <li>• <b>R2 DID</b></li> <li>• <b>R2 DOD</b></li> <li>• <b>R2 DIOD</b></li> <li>• <b>Tie Immediate Start</b></li> <li>• <b>Tie Wink Start</b></li> <li>• <b>Tie Delay Dial</b></li> <li>• <b>Tie Automatic</b></li> <li>• <b>WAN Service</b></li> <li>• <b>Out of Service</b></li> </ul>
<b>Dial Type</b>	<p>Default = MFC Dialing</p> <p>The type of dialing supported by the channel. The options are:, or .</p> <ul style="list-style-type: none"> <li>• <b>MFC Dialing</b></li> <li>• <b>Pulse Dialing</b></li> <li>• <b>DTMF Dialing</b></li> </ul>

**Related links**

[E1 R2 Line](#) on page 304

**E1 R2 MFC Group**

Navigation: **Line | E1–R2 MFC Group**

These settings are not mergeable. Changes to these settings will require a reboot of the system.

These tabs show the parameter assigned to each signal in an MFC group. The defaults are set according to the Country (Locale) on the Line tab. All the values can be returned to default by the **Default All** button on the **Advanced** tab.

These settings are not mergeable. Changes to these settings will require a reboot of the system.

To change a setting either double-click on it or right-click and select **Edit**.

**Related links**

[E1 R2 Line](#) on page 304

**E1-R2 Advanced**

Navigation: **Line | E1R2 Advanced**

These settings are not mergeable. Changes to these settings will require a reboot of the system.

Field	Description
<b>Zero Suppression</b>	Default = HDB3 Selects the method of zero suppression used (HDB3 or AMI).
<b>Clock Quality</b>	Default = Network Refer to the IP Office Installation Manual for full details. This option sets whether the system should try to take its clock source for call synchronization and signalling from this line. Preference should always be given to using the clock source from a central office exchange if available by setting at least one exchange line to <b>Network</b> . <ul style="list-style-type: none"> <li>• If multiple lines are set as <b>Network</b>, the order in which those lines are used is described in the IP Office Installation Manual. If additional lines are available, <b>Fallback</b> can be used to specify a clock source to use should the <b>Network</b> source not be available.</li> <li>• Lines from which the clock source should not be taken should be set as <b>Unsuitable</b>.</li> <li>• If no clock source is available, the system uses its own internal 8KHz clock source.</li> <li>• In scenarios where several systems are network via digital trunk lines, care must be taken to ensure that all the systems use the same clock source. The current source being used by a system is reported within the System Status Application.</li> </ul>
<b>Line Signaling</b>	Default = CPE The options are: <ul style="list-style-type: none"> <li>• <b>CPE</b></li> <li>• <b>CO</b></li> <li>• <b>CO</b></li> </ul> <p>The feature is intended to be used primarily as a testing aid. It allows T1 and E1 lines to be tested in a back-to-back configuration, using crossover (QSIG) cables.</p> <p>The CO feature operates by modifying the way in which incoming calls are disconnected for system configuration in Brazil and Argentina. In these locales, the CO setting uses Forced-Release instead of Clear-Back to disconnect incoming calls. The Brazilian Double-Seizure mechanism used to police Collect calls, is also disabled in CO mode.</p>
<b>Incoming Routing Digits</b>	Default = 4 Sets the number of incoming digits used for incoming call routing.
<b>CRC Checking</b>	Default = On Switches CRC on or off.
<b>Default All Group Settings</b>	Default the MFC Group tab settings.
<b>Line Signaling Timers</b>	To edit one of these timers, either double-click on the timer or right-click on a timer and select the action required.

### Related links

[E1 R2 Line](#) on page 304

## T1 Line

### Related links

[PRI Trunks](#) on page 294

[US T1 Line](#) on page 310

[T1 Channels](#) on page 312

### US T1 Line

Navigation: [Line](#) | [US T1 Line](#)

The following settings are mergeable:

- **Admin**
- **Prefix**

The remaining settings are not mergeable. Changes to these settings require a system reboot.

Field	Description
<b>Line Number</b>	Allocated by the system.
<b>Card/Module</b>	Indicates the card slot or expansion module being used for the trunk device providing the line.  For IP500 V2 control units: 1 to 4 match the slots on the front of the control unit from left to right. Expansion modules are numbered from 5 upwards, for example trunks on the module in Expansion Port 1 are shown as 5.
<b>Port</b>	Indicates the port on the Card/Module above to which the configuration settings relate.
<b>Network Type</b>	Default = Public.  This option is available if <b>System   Telephony   Telephony   Restrict Network Interconnect</b> is enabled. It allows the trunk to be set as either <b>Public</b> or <b>Private</b> . The system will return number busy indication to any attempt to connect a call on a <b>Private</b> trunk to a <b>Public</b> trunk or vice versa. This restriction includes transfers, forwarding and conference calls.  Due to the nature of this feature, its use is not recommended on systems also using any of the following other system features: multi-site networks, VPNremote, application telecommuter mode.
<b>Line Sub Type</b>	Default = T1  Set to T1 for a T1 line.
<b>Channel Allocation</b>	Default = 24   1  The order, 24 to 1 or 1 to 24, in which channels are used.
<b>Prefix</b>	Default = Blank  Enter the number to prefix to all incoming numbers for callback. This is useful if all users must dial a prefix to access an outside line. The prefix is automatically placed in front of all incoming numbers so that users can dial the number back.

*Table continues...*

Field	Description
<b>Framing</b>	<p>Default = ESF</p> <p>Selects the type of signal framing used. The options are:</p> <ul style="list-style-type: none"> <li>• <b>ESF</b></li> <li>• <b>D4</b></li> </ul>
<b>Zero Suppression</b>	<p>Default = B8ZS</p> <p>Selects the method of zero suppression used. The options are:</p> <ul style="list-style-type: none"> <li>• <b>B8ZS</b></li> <li>• <b>AMI ZCS</b></li> </ul>
<b>Clock Quality</b>	<p>Default = Network</p> <p>Refer to the IP Office Installation Manual for full details. This option sets whether the system should try to take its clock source for call synchronization and signalling from this line. Preference should always be given to using the clock source from a central office exchange if available by setting at least one exchange line to <b>Network</b>.</p> <ul style="list-style-type: none"> <li>• If multiple lines are set as <b>Network</b>, the order in which those lines are used is described in the IP Office Installation Manual. If additional lines are available, <b>Fallback</b> can be used to specify a clock source to use should the <b>Network</b> source not be available.</li> <li>• Lines from which the clock source should not be taken should be set as <b>Unsuitable</b>.</li> <li>• If no clock source is available, the system uses its own internal 8KHz clock source.</li> <li>• In scenarios where several systems are network via digital trunk lines, care must be taken to ensure that all the systems use the same clock source. The current source being used by a system is reported within the System Status Application.</li> </ul>
<b>Haul Length</b>	<p>Default = 0-115 feet.</p> <p>Sets the line length to a specific distance.</p>
<b>Channel Unit</b>	<p>Default = Foreign Exchange</p> <p>This field should be set to match the channel signaling equipment provided by the Central Office. The options are:</p> <ul style="list-style-type: none"> <li>• <b>Foreign Exchange</b></li> <li>• <b>Special Access</b></li> <li>• <b>Normal</b></li> </ul>
<b>CRC Checking</b>	<p>Default = On</p> <p>Turns CRC on or off.</p>

*Table continues...*

Field	Description
<b>Line Signaling</b>	<p>Default = CPE</p> <p>This field affects T1 channels set to Loop-Start or Ground-Start. The field can be set to either CPE (Customer Premises Equipment) or CO (Central Office). This field should normally be left at its default of CPE. The setting CO is normally only used in lab back-to-back testing.</p>
<b>Incoming Routing Digits</b>	<p>Default=0 (present call immediately)</p> <p>Sets the number of routing digits expected on incoming calls. This allows the line to present the call to the system once the expected digits have been received rather than waiting for the digits timeout to expire. This field only affects T1 line channels set to E&amp;M Tie, E&amp;M DID, E&amp;M Switched 56K and Direct Inward Dial.</p>
<b>CSU Operation</b>	<p>Enable this field to enable the T1 line to respond to loop-back requests from the line.</p>
<b>Enhanced Called Party Number</b>	<p>Default = Off</p> <p>This option is not supported for systems set to the United States locale. Normally the dialed number length is limited to 15 digits. Selecting this option increases the allowed dialed number length to 30 digits.</p>
<b>Admin</b>	<p>Default = In Service.</p> <p>This field allows a trunk to be taken out of service if required for maintenance or if the trunk is not connected.</p>

**Related links**

[T1 Line](#) on page 310

**T1 Channels**

Navigation: **Line | T1 Channels**

The settings for each channel can be edited. Users have the option of editing individual channels by double-clicking on the channel or selecting and editing multiple channels at the same time. Note that the Line Appearance ID cannot be updated when editing multiple channels.

When editing a channel or channels, the settings available are displayed on two sub-tabs; T1 Edit Channel and Timers.

The following settings are mergeable:

- **Incoming Group ID**
- **Outgoing Group ID**
- **Line Appearance ID**
- **Admin**

The remaining settings are not mergeable. Changes to these settings require a system reboot.



Field	Description
<b>Channel</b>	Allocated by the system.
<b>Incoming Group ID</b>	<p>Default = 0, Range 0 to 99999.</p> <p>The Incoming Group ID to which a line belongs is used to match it to incoming call routes in the system configuration. The matching incoming call route is then used to route incoming calls. The same ID can be used for multiple lines.</p>
<b>Outgoing Group ID</b>	<p>Default = 1. Range 0 to 99999.</p> <p>Short codes that specify a number to dial can specify the line group to be used. The system will then seize a line from those available with a matching Outgoing Group ID.</p> <p>In a Server Edition/Select network, the <b>Outgoing Group ID</b> used for lines to a system must be unique within the network. The same ID cannot be used in the configuration of any lines to another server system in the network.</p> <p><b>Reserved Group ID Numbers:</b></p> <ul style="list-style-type: none"> <li>• <b>90000 - 99999</b> Reserved for system use (not enforced).</li> <li>• <b>99999 and 99998</b> In a Server Edition/Select network, reserved for the IP Office lines to the primary and secondary server respectively.</li> <li>• <b>99001 to 99148</b> In a Server Edition/Select network, reserved for the IP Office lines from the primary and secondary servers to each expansion system in the network.</li> <li>• <b>0</b> In a Server Edition/Select network, the ID 0 cannot be used.</li> <li>• <b>98888</b> For IP Office deployed in an Enterprise Branch environment, reserved for the SM line.</li> </ul>
<b>Line Appearance ID</b>	<p>Default = Auto-assigned. Range = 2 to 9 digits.</p> <p>Used for configuring Line Appearances with button programming. The line appearance ID must be unique and not match any extension number. Line appearance is not supported for trunks set to QSIG operation and is not recommended for trunks be used for DID.</p>
<b>Direction</b>	<p>Default = Bothway</p> <p>The direction of calls on the channel. The options are:</p> <ul style="list-style-type: none"> <li>• <b>Incoming</b></li> <li>• <b>Outgoing</b></li> <li>• <b>Bothway</b></li> </ul>
<b>Bearer</b>	<p>Default = Any</p> <p>The type of traffic carried by the channel. The options are:</p> <ul style="list-style-type: none"> <li>• <b>Voice</b></li> <li>• <b>Data</b></li> <li>• <b>Any</b></li> </ul>

*Table continues...*

Field	Description
<b>Admin</b>	<p>Default = In Service.</p> <p>This field allows a trunk to be taken out of service if required for maintenance or if the trunk is not connected.</p>
<b>Type</b>	<p>Default = Loop-Start.</p> <p>The T1 emulates the following connections:</p> <ul style="list-style-type: none"> <li>• <b>Ground-Start</b></li> <li>• <b>Loop-Start</b></li> <li>• <b>E&amp;M - TIE</b></li> <li>• <b>E&amp;M - DID</b></li> <li>• <b>E&amp;M Switched 56K</b></li> <li>• <b>Direct Inward Dial</b></li> <li>• <b>Clear Channel 64K</b></li> </ul> <p>Trunks set to <b>E&amp;M - DID</b> will only accept incoming calls.</p> <p>If <b>E&amp;M - TIE</b> is selected and the <b>Outgoing Trunk Type</b> is set to <b>Automatic</b>, no secondary dial tone is provided for outgoing calls on this line/trunk.</p>
<b>Dial Type</b>	<p>Default = DTMF Dial</p> <p>Select the dialing method required. The options are:</p> <ul style="list-style-type: none"> <li>• <b>DTMF Dial</b></li> <li>• <b>Pulse Dial</b></li> </ul>
<b>Incoming Trunk Type</b>	<p>Default = Wink-Start</p> <p>Used for E&amp;M types only. The handshake method for incoming calls. The options are:</p> <ul style="list-style-type: none"> <li>• <b>Automatic</b></li> <li>• <b>Immediate</b></li> <li>• <b>Delay Dial</b></li> <li>• <b>Wink-Start</b></li> </ul>
<b>Outgoing Trunk Type</b>	<p>Default = Wink-Start</p> <p>Used for E&amp;M types only. The handshake method for outgoing calls. The options are:</p> <ul style="list-style-type: none"> <li>• <b>Automatic</b></li> <li>• <b>Immediate</b></li> <li>• <b>Delay Dial</b></li> <li>• <b>Wink-Start</b></li> </ul> <p>If the line Type is set to <b>E&amp;M-TIE</b> and the <b>Outgoing Trunk Type</b> is set to <b>Automatic</b>, no secondary dial tone is provided for outgoing calls on this line/trunk.</p>

*Table continues...*

Field	Description
<b>Tx Gain</b>	Default = 0dB. The transmit gain in dB.
<b>Rx Gain</b>	Default = 0dB. The receive gain in dB.
<b>Admin</b>	Default = In Service. This field allows a trunk to be taken out of service if required for maintenance or if the trunk is not connected.

## Timer Settings

This sub-tab allows various timers relating to operation of an individual channel to be adjusted. These should only be adjusted to match the requirements of the line provider. The following is a list of the default values. To reset a value, click on the current value and then right click and select from the default, minimize and maximize options displayed.

**Incoming Automatic Delay:** 410.

**Silent Interval:** 1100.

**Incoming Wink Delay:** 100.

**Outgoing Seizure:** 10.

**Wink Signal:** 200.

**Wink Start:** 5000.

**Incoming Dial Guard:** 50.

**Wink Validated:** 80.

**First Incoming Digit:** 15000.

**Wink End:** 350.

**Incoming Inter Digit:** 5000.

**Delay End:** 5000.

**Maximum Inter Digit:** 300.

**Outgoing Dial Guard:** 590.

**Flash Hook Detect:** 240.

**Outgoing IMM Dial Guard:** 1500.

**Incoming Disconnect:** 300.

**Outgoing Pulse Dial Break:** 60.

**Incoming Disconnect Guard:** 800.

**Outgoing Pulse Dial Make:** 40.

**Disconnected Signal Error:** 240000.

**Outgoing Pulse Dial Inter Digit:** 720.

**Outgoing Disconnect:** 300.

**Outgoing Pulse Dial Pause:** 1500.

**Outgoing Disconnect Guard:** 800.

**Flash Hook Generation:** 500.

**Ring Verify Duration:** 220.

**Outgoing End of Dial:** 1000.

**Ring Abandon:** 6300.

**Answer Supervision:** 300.

**Ping Verify:** 600.

**Incoming Confirm:** 20.

**Long Ring Time:** 1100.

### Related links

[T1 Line](#) on page 310

## T1 PRI Line

### Related links

[PRI Trunks](#) on page 294

[T1 ISDN](#) on page 316

[T1 ISDN Channels](#) on page 320

[T1 ISDN TNS](#) on page 322

[T1 ISDN Special](#) on page 323

[Call By Call \(US PRI\)](#) on page 324

## T1 ISDN

Navigation: **Line | T1 ISDN Line**

The following settings are mergeable:

- **Prefix**
- **Send Redirecting Number**
- **Admin**
- **Send original calling party for forwarded and twinning calls**
- **Originator number for forwarded and twinning calls**

The remaining settings are not mergeable. Changes to these settings require a system reboot.

Variable	Description
<b>Line Number</b>	Allocated by the system.
<b>Card/Module</b>	Indicates the card slot or expansion module being used for the trunk device providing the line.  For IP500 V2 control units: 1 to 4 match the slots on the front of the control unit from left to right. Expansion modules are numbered from 5 upwards, for example trunks on the module in Expansion Port 1 are shown as 5.
<b>Port</b>	Indicates the port on the Card/Module above to which the configuration settings relate.
<b>Network Type</b>	Default = Public.  This option is available if <b>System   Telephony   Telephony   Restrict Network Interconnect</b> is enabled. It allows the trunk to be set as either <b>Public</b> or <b>Private</b> . The system will return number busy indication to any attempt to connect a call on a <b>Private</b> trunk to a <b>Public</b> trunk or vice versa. This restriction includes transfers, forwarding and conference calls.  Due to the nature of this feature, its use is not recommended on systems also using any of the following other system features: multi-site networks, VPNremote, application telecommuter mode.
<b>Line Sub Type</b>	: Default = PRI  Set to <b>PRI</b> . If set to T1 see Line Form (T1). If set to <b>ETSI, ETSI CHI, QSIG A</b> or <b>QSIG B</b> see Line (E1).  QSIG trunks are not supported on IP500 V2 systems without IP500 Voice Networking licenses.

*Table continues...*

Variable	Description
<b>Channel Allocation</b>	Default = 23   1 The order, 23 to 1 or 1 to 23, in which channels are used.
<b>Switch Type</b>	Default = NI2 The options are <ul style="list-style-type: none"> <li>• <b>4ESS</b></li> <li>• <b>5ESS</b></li> <li>• <b>DMS100</b></li> <li>• <b>NI2</b></li> </ul>
<b>Provider</b>	Default = Local Telco Select the PSTN service provider ( <b>AT&amp;T</b> , <b>Sprint</b> , <b>WorldCom</b> or <b>Local Telco</b> ).
<b>Prefix</b>	Default = Blank Enter the number to prefix to all incoming numbers for callback. This is useful if all users must dial a prefix to access an outside line. The prefix is automatically placed in front of all incoming numbers so that users can dial the number back.
<b>Add 'Not-end-to-end ISDN' Information Element</b>	Default = Never*. Sets whether the optional 'Not end-to-end ISDN' information element should be added to outgoing calls on the line. The options are <ul style="list-style-type: none"> <li>• <b>Never</b></li> <li>• <b>Always</b></li> <li>• <b>POTS</b> (only if the call was originated by an analog extension)</li> </ul> <p>*The default is <b>Never</b> except for the following locales; for Italy the default is <b>POTS</b>, for New Zealand the default is <b>Always</b>.</p>
<b>Progress Replacement</b>	Default = None. Progress messages are defined in the Q.931 ISDN connection control signaling protocol. Generally, If a progress message is sent, the caller does not get connected and so typically does not accrue call costs. Not all ISDN lines support Q.931 Progress messages. Use this setting to configure alternative signaling to the ISDN line for internally generated Progress messages. The options are: <ul style="list-style-type: none"> <li>• <b>Alerting</b>: Map to Q.931 Alerting. The call is not connected. The caller does not hear the message and typically does not accrue call costs.</li> <li>• <b>Connect</b>: Map to Q.931 Connect. The caller hears the message and typically will accrue call costs.</li> </ul>

*Table continues...*

Variable	Description
<b>Send Redirecting Number</b>	<p>Default = Off.</p> <p>This option can be used on ISDN trunks where the redirecting service is supported by the trunk provider. Where supported, on twinned calls the caller ID of the original call is passed through to the twinning destination. This option is only used for twinned calls.</p>
<b>Send Names</b>	<p>This option is available when the <b>Switch Type</b> above is set to <b>DMS100</b>. If set, names are sent in the display field. The <b>Z</b> shortcode character can be used to specify the name to be used.</p>
<b>Names Length</b>	<p>Set the allowable length for names, up to 15 characters, when <b>Send Names</b> is set above.</p>
<b>Test Number</b>	<p>Used to remember the external telephone number of this line to assist with loop-back testing. For information only.</p>
<b>Framing</b>	<p>Default = ESF</p> <p>Selects the type of signal framing used (ESF or D4).</p>
<b>Zero Suppression</b>	<p>Default = B8ZS</p> <p>Selects the method of zero suppression used (B8ZS or AMI ZCS).</p>
<b>Clock Quality</b>	<p>Default = Network</p> <p>Refer to the IP Office Installation Manual for full details. This option sets whether the system should try to take its clock source for call synchronization and signalling from this line. Preference should always be given to using the clock source from a central office exchange if available by setting at least one exchange line to <b>Network</b>.</p> <ul style="list-style-type: none"> <li>• If multiple lines are set as <b>Network</b>, the order in which those lines are used is described in the IP Office Installation Manual. If additional lines are available, <b>Fallback</b> can be used to specify a clock source to use should the <b>Network</b> source not be available.</li> <li>• Lines from which the clock source should not be taken should be set as <b>Unsuitable</b>.</li> <li>• If no clock source is available, the system uses its own internal 8KHz clock source.</li> <li>• In scenarios where several systems are network via digital trunk lines, care must be taken to ensure that all the systems use the same clock source. The current source being used by a system is reported within the System Status Application.</li> </ul>
<b>CSU Operation</b>	<p>Tick this field to enable the T1 line to respond to loop-back requests from the line.</p>
<b>Haul Length</b>	<p>Default = 0-115 feet</p> <p>Sets the line length to a specific distance.</p>

*Table continues...*

Variable	Description
<b>Channel Unit</b>	Default = Foreign Exchange This field should be set to match the channel signaling equipment provided by the Central Office. The options are <ul style="list-style-type: none"> <li>• <b>Foreign Exchange</b></li> <li>• <b>Special Access</b></li> <li>• <b>Normal</b></li> </ul>
<b>CRC Checking</b>	Default = On Turns CRC on or off.
<b>Line Signaling</b>	The field can be set to either <b>CPE</b> (Customer Premises Equipment) or <b>CO</b> (Central Office). This field should normally be left at its default of <b>CPE</b> . The setting <b>CO</b> is normally only used in lab back-to-back testing.
<b>Incoming Routing Digits</b>	Default=0 (present call immediately) Sets the number of routing digits expected on incoming calls. This allows the line to present the call to the system once the expected digits have been received rather than waiting for the digits timeout to expire. This field only affects T1 line channels set to <b>E&amp;M Tie</b> , <b>E&amp;M DID</b> , <b>E&amp;M Switched 56K</b> and <b>Direct Inward Dial</b> .
<b>Admin</b>	Default = In Service. This field allows a trunk to be taken out of service if required for maintenance or if the trunk is not connected.
<b>Send original calling party for forwarded and twinning calls</b>	Default = Off. Use the original calling party ID when forwarding calls or routing twinned calls. This setting applies to the following ISDN lines: <ul style="list-style-type: none"> <li>• PRI24 with subtypes:               <ul style="list-style-type: none"> <li>- PRI</li> <li>- QSIGA</li> <li>- QSIGB</li> <li>- ETSI</li> <li>- ETSI CHI</li> </ul> </li> <li>• PRI30 with subtypes               <ul style="list-style-type: none"> <li>- QSIGA</li> <li>- QSIGB</li> <li>- ETSI</li> <li>- ETSI CHI</li> </ul> </li> </ul>

*Table continues...*

Variable	Description
<b>Originator number for forwarded and twinning calls</b>	<p>Default = blank.</p> <p>The number used as the calling party ID when forwarding calls or routing twinned calls. This field is grayed out when the <b>Send original calling party for forwarded and twinning calls</b> setting is enabled.</p> <p>This setting applies to the following ISDN lines:</p> <ul style="list-style-type: none"> <li>• PRI24 with subtypes: <ul style="list-style-type: none"> <li>- PRI</li> <li>- QSIGA</li> <li>- QSIGB</li> <li>- ETSI</li> <li>- ETSI CHI</li> </ul> </li> <li>• PRI30 with subtypes <ul style="list-style-type: none"> <li>- QSIGA</li> <li>- QSIGB</li> <li>- ETSI</li> <li>- ETSI CHI</li> </ul> </li> </ul>

**Related links**

[T1 PRI Line](#) on page 315

**T1 ISDN Channels**

Navigation: **Line | T1 ISDN Channels**

This tab allows settings for individual channels within the trunk to be adjusted. This tab is not available for trunks sets to ETSI or QSIG mode.

The following settings are mergeable:

- **Incoming Group ID**
- **Outgoing Group ID**
- **Line Appearance ID**
- **Admin**

The remaining settings are not mergeable. Changes to these settings require a system reboot.

Field	Description
<b>Channel</b>	Allocated by the system.

*Table continues...*



Field	Description
<b>Incoming Group ID</b>	<p>Default = 0, Range 0 to 99999.</p> <p>The Incoming Group ID to which a line belongs is used to match it to incoming call routes in the system configuration. The matching incoming call route is then used to route incoming calls. The same ID can be used for multiple lines.</p>
<b>Outgoing Group ID</b>	<p>Default = 1. Range 0 to 99999.</p> <p>Short codes that specify a number to dial can specify the line group to be used. The system will then seize a line from those available with a matching Outgoing Group ID.</p> <p>In a Server Edition/Select network, the <b>Outgoing Group ID</b> used for lines to a system must be unique within the network. The same ID cannot be used in the configuration of any lines to another server system in the network.</p> <p><b>Reserved Group ID Numbers:</b></p> <ul style="list-style-type: none"> <li>• <b>90000 - 99999</b> Reserved for system use (not enforced).</li> <li>• <b>99999 and 99998</b> In a Server Edition/Select network, reserved for the IP Office lines to the primary and secondary server respectively.</li> <li>• <b>99001 to 99148</b> In a Server Edition/Select network, reserved for the IP Office lines from the primary and secondary servers to each expansion system in the network.</li> <li>• <b>0</b> In a Server Edition/Select network, the ID 0 cannot be used.</li> <li>• <b>98888</b> For IP Office deployed in an Enterprise Branch environment, reserved for the SM line.</li> </ul>
<b>Line Appearance ID</b>	<p>Default = Auto-assigned. Range = 2 to 9 digits.</p> <p>Used for configuring Line Appearances with button programming. The line appearance ID must be unique and not match any extension number.</p>
<b>Direction</b>	<p>Default = Both Directions</p> <p>The direction of calls on the channel. The options are:</p> <ul style="list-style-type: none"> <li>• <b>Incoming</b></li> <li>• <b>Outgoing</b></li> <li>• <b>Both Directions</b></li> </ul>
<b>Bearer</b>	<p>Default = Any</p> <p>The type of traffic carried by the channel. The options are:</p> <ul style="list-style-type: none"> <li>• <b>Voice</b></li> <li>• <b>Data</b></li> <li>• <b>Any</b></li> </ul>

*Table continues...*

Field	Description
<b>Service</b>	<p>Default = None.</p> <p>If the line provider is set to AT&amp;T, select the type of service provided by the channel. The options are:</p> <ul style="list-style-type: none"> <li>• <b>Call by Call</b></li> <li>• <b>SDN (inc GSDN)</b></li> <li>• <b>MegaCom 800</b></li> <li>• <b>MegaCom</b></li> <li>• <b>Wats</b></li> <li>• <b>Accunet</b></li> <li>• <b>ILDS</b></li> <li>• <b>I800</b></li> <li>• <b>ETN</b></li> <li>• <b>Private Line</b></li> <li>• <b>AT&amp;T Multiquest</b></li> </ul> <p>For other providers, the service options are <b>None</b> or <b>No Service</b>.</p>
<b>Admin</b>	<p>Default = Out of Service</p> <p>Used to indicate the channel status. The options are:</p> <ul style="list-style-type: none"> <li>• <b>In Service</b></li> <li>• <b>Out of Service</b></li> <li>• <b>Maintenance</b></li> </ul>
<b>Tx Gain</b>	<p>Default = 0dB</p> <p>The transmit gain in dB</p>
<b>Rx Gain</b>	<p>Default = 0dB</p> <p>The receive gain in dB.</p>

**Related links**

[T1 PRI Line](#) on page 315

**T1 ISDN TNS**

Navigation: [Line](#) | **T1 ISDN TNS**

This tab is shown when the line Provider is set to AT&T. It allows the entry of the Network Selection settings. These are prefixes for alternative long distance carriers. When a number dialed matches an entry in the table, that pattern is stripped from the number before being sent out. This table is used to set field in the TNS (Transit Network Selection) information element for 4ESS and 5ESS exchanges. It is also used to set fields in the NSF information element.

These settings are not mergeable. Changes to these settings will require a reboot of the system.

Field	Description
<b>TNS Code</b>	The pattern for the alternate long distance carrier. For example: The pattern 10XXX is added to this tab. If 10288 is dialed, 10 is removed and 288 is placed in the TNS and NSF information.

### Related links

[T1 PRI Line](#) on page 315

## T1 ISDN Special

Navigation: **Line | T1 ISDN Special**

This tab is shown when the line Provider is set to AT&T. This table is used to set additional fields in the NSF information element after initial number parsing by the TNS tab. These are used to indicate the services required by the call. If the channel is set to Call by Call, then further parsing is done using the records in the Call by Call tab.

These settings are not mergeable. Changes to these settings will require a reboot of the system.

Field	Description
<b>Short code</b>	The number which results from the application of the rules specified in the User or System Short code tables and the Network Selection table and the Call-by-call table to the number dialed by the user.
<b>Number</b>	The number to be dialed to line.
<b>Special</b>	Default = No Operator. The options are: <ul style="list-style-type: none"> <li>• <b>No Operator</b></li> <li>• <b>Local Operator</b></li> <li>• <b>Presubscribed Operator</b></li> </ul>
<b>Plan</b>	Default = National. The options are: <ul style="list-style-type: none"> <li>• <b>National</b></li> <li>• <b>International</b></li> </ul>

Typical values are:

Short Code	Number	Service
<b>011N</b>	N	No Operator, International
<b>010N</b>	N	Local Operator, International
<b>01N</b>	N	Local Operator, National
<b>00N</b>	N	Presubscribed Operator, National
<b>0N</b>	N	Presubscribed Operator, National
<b>1N</b>	1N	No operator, National

**Related links**

[T1 PRI Line](#) on page 315

**Call By Call (US PRI)**

Navigation: **Line | T1 ISDN Call by Call**

This tab is shown when the line Provider is set to AT&T. Settings in this tab are only used when calls are routed via a channel which has its **Service** set to **Call by Call**.

It allows short codes to be created to route calls to a different services according to the number dialed. Call By Call reduces the costs and maximizes the use of facilities. Call By Call chooses the optimal service for a particular call by including the Bearer capability in the routing decision. This is particularly useful when there are limited resources.

These settings are not mergeable. Changes to these settings will require a reboot of the system.

Field	Description
<b>Short Code</b>	The number which results from the application of the rules specified in the User or System Short code tables and the Network Selection table to the number dialed by the user.
<b>Number</b>	The number to be dialed to line.
<b>Bearer</b>	Default = Any The type of traffic carried by the channel. The options are: <ul style="list-style-type: none"> <li>• <b>Voice</b></li> <li>• <b>Data</b></li> <li>• <b>Any</b></li> </ul>
<b>Service</b>	Default = AT&T The service required by the call. The options are: <ul style="list-style-type: none"> <li>• <b>Call by Call</b></li> <li>• <b>SDN (inc GSDN)</b></li> <li>• <b>MegaCom 800</b></li> <li>• <b>MegaCom</b></li> <li>• <b>Wats</b></li> <li>• <b>Accunet</b></li> <li>• <b>ILDS</b></li> <li>• <b>I800</b></li> <li>• <b>ETN</b></li> <li>• <b>Private Line</b></li> <li>• <b>AT&amp;T Multiquest</b></li> </ul>

**Related links**

[T1 PRI Line](#) on page 315

## S0 Line



These settings are used for S0 ports provided by an S08 expansion module connected a control unit. For full details of installation refer to the IP Office Installation manual.

Though displayed as lines, these BRI ports are used for connection of ISDN2 devices such as video conferencing units or ISDN PC cards.

Calls received on IP, S0 and QSIG trunks do not use incoming call routes. Routing for these is based on incoming number received as if dialed on-switch. Line short codes on those trunks can be used to modify the incoming digits.

### Related links

[Line](#) on page 279

[S0 Line](#) on page 325

[S0 Short Codes](#) on page 327

[Line | S0 Channels](#) on page 328

## S0 Line

Navigation: [Line](#) | [S0 Line](#)

The following settings are not mergeable. Changes to these settings require a system reboot.

- **Line Sub Type**
- **Network Type**

The remaining settings are mergeable.

Field	Description
<b>Line Number</b>	This parameter is not configurable. It is allocated by the system.
<b>Card/Module</b>	Indicates the card slot or expansion module being used for the trunk device providing the line.  For IP500 V2 control units: 1 to 4 match the slots on the front of the control unit from left to right. Expansion modules are numbered from 5 upwards, for example trunks on the module in Expansion Port 1 are shown as 5.
<b>Port</b>	Indicates the port on the Card/Module above to which the configuration settings relate.
<b>Line Sub Type</b>	Default = ETSI Select to match the particular line type provided by the line provider.

*Table continues...*

Field	Description
<b>Network Type</b>	<p>Default = Public.</p> <p>This option is available if <b>Restrict Network Interconnect (System   Telephony   Telephony)</b> is enabled. It allows the trunk to be set as either <b>Public</b> or <b>Private</b>. The system will return number busy indication to any attempt to connect a call on a <b>Private</b> trunk to a <b>Public</b> trunk or vice versa. This restriction includes transfers, forwarding and conference calls.</p> <p>Due to the nature of this feature, its use is not recommended on systems also using any of the following other system features: multi-site networks, VPNremote, application telecommuter mode.</p>
<b>Telephone Number</b>	Used to remember the telephone number of this line. For information only.
<b>Prefix</b>	<p>Default = Blank.</p> <p>The prefix is used in the following ways:</p> <ul style="list-style-type: none"> <li>• <b>For incoming calls</b> The ISDN messaging tags indicates the call type (National, International or Unknown). If the call type is unknown, then the number in the Prefix field is added to the ICLID.</li> <li>• <b>For outgoing calls</b> The prefix is not stripped, therefore any prefixes not suitable for external line presentation should be stripped using short codes.</li> </ul>
<b>National Prefix</b>	<p>Default = 0</p> <p>This indicates the digits to be prefixed to a incoming national call. When a number is presented from ISDN as a "national number" this prefix is added. For example 1923000000 is converted to 01923000000.</p>
<b>International Prefix</b>	<p>Default = 00</p> <p>This indicates the digits to be prefixed to an incoming international call. When a number is presented from ISDN as an "international number" this prefix is added. For example 441923000000 is converted to 00441923000000.</p>
<b>Incoming Group ID</b>	<p>Default = 0, Range 0 to 99999.</p> <p>The Incoming Group ID to which a line belongs is used to match it to incoming call routes in the system configuration. The matching incoming call route is then used to route incoming calls. The same ID can be used for multiple lines.</p>

*Table continues...*

Field	Description
<b>Outgoing Group ID</b>	<p>Default = 1. Range 0 to 99999.</p> <p>Short codes that specify a number to dial can specify the line group to be used. The system will then seize a line from those available with a matching Outgoing Group ID.</p> <p>In a Server Edition/Select network, the <b>Outgoing Group ID</b> used for lines to a system must be unique within the network. The same ID cannot be used in the configuration of any lines to another server system in the network.</p> <p><b>Reserved Group ID Numbers:</b></p> <ul style="list-style-type: none"> <li>• <b>90000 - 99999</b> Reserved for system use (not enforced).</li> <li>• <b>99999 and 99998</b> In a Server Edition/Select network, reserved for the IP Office lines to the primary and secondary server respectively.</li> <li>• <b>99001 to 99148</b> In a Server Edition/Select network, reserved for the IP Office lines from the primary and secondary servers to each expansion system in the network.</li> <li>• <b>0</b> In a Server Edition/Select network, the ID 0 cannot be used.</li> <li>• <b>98888</b> For IP Office deployed in an Enterprise Branch environment, reserved for the SM line.</li> </ul>
<b>TEI</b>	<p>Default = 0</p> <p>Not used. The Control Unit will ignore any entry.</p>
<b>Number of Channels</b>	<p>Default = 2</p> <p>Defines the number of operational channels that are available on this line. 2 for BRI and up to 30 for PRI - depending upon the number of channels subscribed.</p>
<b>Outgoing Channels</b>	<p>Default = 2</p> <p>This defines the number of channels available, on this line, for outgoing calls. This should normally be the same as Number of Channels field, but can be reduced to ensure incoming calls cannot be blocked by outgoing calls.</p>
<b>Voice Channels</b>	<p>Default = 2</p> <p>The number of channels available for voice use.</p>
<b>Data Channels</b>	<p>Default = 2</p> <p>The number of channels available for data use. If left blank the value is 0.</p>

### Related links

[S0 Line](#) on page 325

## S0 Short Codes

Navigation: [Line](#) | [S0 Line](#) | [Short Codes](#)

For BRI S0 lines , these settings are mergeable.

For some types of line, Line short codes can be applied to any digits received with incoming calls.

The line Short Code tab is shown for the following trunk types which are treated as internal or private trunks: **QSIG** (T1, E1, H.323), **BRI S0**, **H.323**, **SCN**, **IP Office**. Incoming calls on those

types of trunk are not routed using **Incoming Call Route** settings. Instead the digits received with incoming calls are checked for a match as follows:

Extension number (including remote numbers in a multi-site network).

- Line short codes (excluding ? short code).
- System short codes (excluding ? short code).
- Line ? short code.
- System ? short code.

Short codes can be added and edited using the **Add**, **Remove** and **Edit** buttons. Alternatively you can right-click on the list of existing short code to add and edit short codes.

#### Related links

[S0 Line](#) on page 325

## Line | S0 Channels

Navigation: **Line | S0 Line | Channels**

For S0 channels this form is not used.

#### Related links

[S0 Line](#) on page 325

---

## H.323 Line

These lines are added manually. They allow voice calls to be routed over data links within the system. They are therefore dependent on the IP data routing between the system and the destination having being configured and tested.

Calls received on IP, S0 and QSIG trunks do not use incoming call routes. Routing for these is based on incoming number received as if dialed on-switch. Line short codes on those trunks can be used to modify the incoming digits.

### Network Assessments

Not all data connections are suitable for voice traffic. A network assessment is required for internal network connections. For external network connections a service level agreement is required from the service provider. Avaya cannot control or be held accountable for the suitability of a data connection for carrying voice traffic.

QSIG trunks are not supported on IP500 V2 systems without IP500 Voice Networking licenses.

This type of configuration record can be saved as a template and new records created from a template. See [Working with Templates](#) on page 600.

#### Related links

[Line](#) on page 279

[VoIP Line](#) on page 329

[Short Codes](#) on page 331

[VoIP Settings](#) on page 331



## VoIP Line

Navigation: [Line](#) | [H.323 Line](#) | [VoIP Line](#)

### Configuration Settings

These settings are mergeable. Changes to these settings does not require a reboot of the system.

Field	Description
<b>Line Number</b>	Default = Auto-filled. Range = 1 to 249 (IP500 V2)/349 (Server Edition). Enter the line number that you wish. Note that this must be unique. On IP500 V2 systems, line numbers 1 to 16 are reserved for internal hardware.
<b>Telephone Number</b>	Used to remember the telephone number of this line. For information only.
<b>Network Type</b>	Default = Public.  This option is available if <b>System   Telephony   Telephony   Restrict Network Interconnect</b> is enabled. It allows the trunk to be set as either <b>Public</b> or <b>Private</b> . The system will return number busy indication to any attempt to connect a call on a <b>Private</b> trunk to a <b>Public</b> trunk or vice versa. This restriction includes transfers, forwarding and conference calls.  Due to the nature of this feature, its use is not recommended on systems also using any of the following other system features: multi-site networks, VPNremote, application telecommuter mode.
<b>Prefix</b>	Default = Blank.  The prefix is used in the following ways: <ul style="list-style-type: none"> <li>• <b>For incoming calls</b> The ISDN messaging tags indicates the call type (National, International or Unknown). If the call type is unknown, then the number in the Prefix field is added to the ICLID.</li> <li>• <b>For outgoing calls</b> The prefix is not stripped, therefore any prefixes not suitable for external line presentation should be stripped using short codes.</li> </ul>
<b>National Prefix</b>	Default = 0  This indicates the digits to be prefixed to a incoming national call. When a number is presented from ISDN as a "national number" this prefix is added. For example 1923000000 is converted to 01923000000.
<b>International Prefix</b>	Default = 00  This indicates the digits to be prefixed to an incoming international call. When a number is presented from ISDN as an "international number" this prefix is added. For example 441923000000 is converted to 00441923000000.

*Table continues...*

Field	Description
<b>Location</b>	<p>Default = Cloud.</p> <p>Specify a location to associate the extension with a physical location. Associating an extension with a location:</p> <ul style="list-style-type: none"> <li>• Allows emergency services to identify the source of an emergency call.</li> <li>• Allows you to configure call admission control settings for the location.</li> </ul> <p>The drop down list contains all locations that have been defined on <b>Location   Location</b>.</p>
<b>Description</b>	<p>Default = Blank. Maximum 31 characters.</p> <p>Use this field to enter a description of this configuration.</p>
<b>Send original calling party for forwarded and twinning calls</b>	<p>Default = Off.</p> <p>Use the original calling party ID when forwarding calls or routing twinned calls.</p>
<b>Outgoing Group ID</b>	<p>Default = 1. Range 0 to 99999.</p> <p>Short codes that specify a number to dial can specify the line group to be used. The system will then seize a line from those available with a matching Outgoing Group ID.</p> <p>In a Server Edition/Select network, the <b>Outgoing Group ID</b> used for lines to a system must be unique within the network. The same ID cannot be used in the configuration of any lines to another server system in the network.</p> <p><b>Reserved Group ID Numbers:</b></p> <ul style="list-style-type: none"> <li>• <b>90000 - 99999</b> Reserved for system use (not enforced).</li> <li>• <b>99999 and 99998</b> In a Server Edition/Select network, reserved for the IP Office lines to the primary and secondary server respectively.</li> <li>• <b>99001 to 99148</b> In a Server Edition/Select network, reserved for the IP Office lines from the primary and secondary servers to each expansion system in the network.</li> <li>• <b>0</b> In a Server Edition/Select network, the ID 0 cannot be used.</li> <li>• <b>98888</b> For IP Office deployed in an Enterprise Branch environment, reserved for the SM line.</li> </ul>
<b>Number of Channels</b>	<p>Default = 20, Range 1 to 250.</p> <p>Defines the number of operational channels that are available on this line.</p>
<b>Outgoing Channels</b>	<p>Default = 20, Range 0 to 250.</p> <p>This defines the number of channels available, on this line, for outgoing calls. This should normally be the same as Number of Channels field, but can be reduced to ensure incoming calls cannot be blocked by outgoing calls.</p>

*Table continues...*

Field	Description
TEI	<p>Default = 0. Range = 0 to 127.</p> <p>The Terminal Equipment Identifier. Used to identify each Control Unit connected to a particular ISDN line. For Point to Point lines this is typically (always) 0. It can also be 0 on a Point to Multi-Point line, however if multiple devices are actually sharing a Point to Multi-Point line it should be set to 127 which will result in the exchange deciding on the TEI's to be used by this Control Unit.</p>

### Related links

[H.323 Line](#) on page 328

## Short Codes

Navigation: [Line](#) | [H.323 Line](#) | [Short Codes](#)

For some types of line, Line short codes can be applied to any digits received with incoming calls.

The line Short Code tab is shown for the following trunk types which are treated as internal or private trunks: **QSIG** (T1, E1, H.323), **BRI S0**, **H.323**, **SCN**, **IP Office**. Incoming calls on those types of trunk are not routed using **Incoming Call Route** settings. Instead the digits received with incoming calls are checked for a match as follows:

Extension number (including remote numbers in a multi-site network).

- Line short codes (excluding ? short code).
- System short codes (excluding ? short code).
- Line ? short code.
- System ? short code.

Short codes can be added and edited using the **Add**, **Remove** and **Edit** buttons. Alternatively you can right-click on the list of existing short code to add and edit short codes.

Changes to these settings do not require a reboot of the system.

### Related links

[H.323 Line](#) on page 328

## VoIP Settings

Navigation: [Line](#) | [H.323 Line](#) | [VoIP Settings](#)

This form is used to configure the VoIP setting applied to calls on the H.323 line.

### Configuration Settings

These settings are mergeable. Changes to these settings does not require a reboot of the system.

Field	Description
Gateway IP Address	<p>Default = Blank</p> <p>Enter the IP address of the gateway device at the remote end.</p>

*Table continues...*

Field	Description
<b>Port</b>	<p>Default = 1720</p> <p>The H.323 line is identified by the IP Address:Port value. Specifying a unique port value for this IP address allows multiple lines to use the same IP address.</p>
<b>Codec Selection</b>	<p>Default = System Default</p> <p>This field defines the codec or codecs offered during call setup. The available codecs in default preference order are:</p> <ul style="list-style-type: none"> <li>• <b>G.711 A-Law</b></li> <li>• <b>G.711 U-LAW</b></li> <li>• <b>G.729</b></li> <li>• <b>G.723.1</b></li> </ul> <p>Note that the default order for G.711 codecs varies to match the system's default companding setting. <b>G.723.1</b> is not supported on Linux based systems.</p> <p>The <b>G.722 64K</b> codec is also supported on IP500 V2 systems with IP500 VCM, IP500 VCM V2 or IP500 Combo cards. For Server Edition, it is supported on Primary Server, Secondary Server and Expansion System (L) systems and on Expansion System (V2) systems fitted with IP500 VCM, IP500 VCM V2 or IP500 Combo.</p> <p>The codecs available in this form are set through the codec list on <b>System   VoIP</b>.</p> <p>Within a network of systems, it is strongly recommended that all the systems and the lines connecting those systems use the same codecs.</p> <p>The options are:</p> <ul style="list-style-type: none"> <li>• <b>System Default</b> This is the default setting. When selected, the codec list below matches the codecs set in the system wide list.</li> <li>• <b>Custom</b> This option allows specific configuration of the codec preferences to be different from the system list. When <b>Custom</b> is selected, the list can be used to select which codecs are in the <b>Unused</b> list and in the <b>Selected</b> list and to change the order of the selected codecs.</li> </ul>
<b>Supplementary Services</b>	<p>Default = H450.</p> <p>Selects the supplementary service signaling method for use across the H.323 trunk. The remote end of the trunk must support the same option. The options are:</p> <ul style="list-style-type: none"> <li>• <b>None</b>: No supplementary services are supported.</li> <li>• <b>H450</b>: Use for H.323 lines connected to another PBX or device that uses H450.</li> <li>• <b>QSIG</b>: Use for H.323 lines connected to another PBX or device that uses QSIG.</li> </ul>
<b>Call Initiation Timeout</b>	<p>Default = 4 seconds. Range = 1 to 99 seconds.</p> <p>This option sets how long the system should wait for a response to its attempt to initiate a call before following the alternate routes set in an ARS form.</p>

*Table continues...*

Field	Description
<b>VoIP Silence Suppression</b>	<p>Default = Off.</p> <p>When selected, this option will detect periods of silence on any call over the line and will not send any data during those silent periods. This feature is not used on IP lines using <b>G.711</b> between systems. On trunk's between networked systems, the same setting should be set at both ends.</p>
<b>Enable FastStart for non-Avaya IP Phones</b>	<p>Default = Off</p> <p>A fast connection procedure. Reduces the number of messages that need to be exchanged before an audio channel is created.</p>
<b>Fax Transport Support</b>	<p>Default = Off</p> <p>This option is only supported on trunks with their <b>Supplementary Services</b> set to <b>IP Office SCN</b> or <b>IP Office Small Community Network - Fallback</b>. Fax relay is supported across H.323 multi-site network lines with <b>Fax Transport Support</b> selected. This will use 2 VCM channels in each of the systems. Fax relay is only supported on IP500 V2 systems with IP500 VCM, IP500 VCM V2 and or IP500 Combo cards. Fax relay is not supported on Server Edition Linux servers.</p>
<b>Local Tones</b>	<p>Default = Off</p> <p>When selected, the tones are generated by the local system to which the phone is registered. This option should not be used with lines being used for a multi-site network.</p>
<b>DTMF Support</b>	<p>Default = Out of Band</p> <p>DTMF tones can be sent to the remote end either as DTMF tones within the calls audio path (<b>In Band</b>) or a separate signals (<b>Out of Band</b>). Out of Band is recommended for compression modes such as G.729 and G.723 compression modes where DTMF in the voice stream could become distorted.</p>
<b>Allow Direct Media Path</b>	<p>Default = On</p> <p>This settings controls whether IP calls must be routed via the system or can be routed alternatively if possible within the network structure.</p> <ul style="list-style-type: none"> <li>• If enabled, IP calls can take routes other than through the system, removing the need for system resources such as voice compression channels. Both ends of the calls must support Direct Media and have compatible VoIP settings such as matching codec, etc. If otherwise, the call will remain routed via the system. Enabling this option may cause some vendors problems with changing the media path mid call.</li> <li>• If disabled, the call is routed via the system. In that case, RTP relay support may still allow calls between devices using the same audio codec to not require a voice compression channel.</li> </ul>

*Table continues...*

Field	Description
<b>Progress Ends Overlap Send</b>	Default = Off. Some telephony equipment, primarily AT&T switches, over IP trunks send a H.323 Progress rather than H.323 Proceeding message to signal that they have recognized the digits sent in overlap state. By default the system expects an H.323 Proceeding message. This option is not available by default. If required, the value <b>ProgressEndsOverlapSend</b> must be entered into the Source Numbers tab of the NoUser user.
<b>Default Name From Display IE</b>	Default = Off. When set, the Display IE is used as the default source for the name.

**Related links**

[H.323 Line](#) on page 328

## IP DECT Line

This type of line can be manually added. They are used to route voice calls over an IP data connection to an Avaya IP DECT system. Only one IP DECT line can be added to a system. Refer to the IP DECT R4 Installation manual for full details.

Currently, only one IP DECT line is supported on a system.

This type of configuration record can be saved as a template and new records created from a template. See [Working with Templates](#) on page 600.

**Related links**

[Line](#) on page 279

[Line | IP DECT Line](#) on page 334

[Gateway](#) on page 335

[VoIP](#) on page 337

## Line | IP DECT Line

Navigation: [Line | IP DECT Line | Line](#)

When creating an IP DECT line, these settings are mergeable. You can also remove an IP DECT line without rebooting. Changing an IP DECT line that has been imported into the configuration is not mergeable.

Field	Description
<b>Line Number</b>	This number is allocated by the system and is not adjustable.
<b>Associated Extensions</b>	Lists all the DECT extensions associated with the IP DECT line.
<b>Description</b>	Default = Blank. Maximum 31 characters. Use this field to enter a description of this configuration.

## Related links

[IP DECT Line](#) on page 334

## Gateway

Navigation: [Line](#) | [IP DECT Line](#) | [Gateway](#)

This form is used to configure aspects of information exchange between the IP Office and IP DECT systems.

When creating an IP DECT line, these settings are mergeable. You can also remove an IP DECT line without rebooting. Changing an IP DECT line that has been imported into the configuration is not mergeable.

Field	Description
<b>Auto-Create Extension</b>	<p>Default = Off.</p> <p>If enabled, subscription of a handset with the DECT system causes the auto-creation of a matching numbered extension within the system configuration if one does not already exist. This setting is not supported on systems configured to use WebLM server licensing.</p> <p>For security, auto-create is automatically disabled after 24 hours.</p>
<b>Auto-Create User</b>	<p>Default = Off.</p> <p>This option is only usable if <b>Auto-Create Extension</b> is also enabled. If enabled, subscription of a handset with the DECT system causes the auto-creation of a matching user within the system configuration if one does not already exist.</p> <p>For security, any auto-create settings set to On are automatically set to Off after 24 hours.</p>
<b>Enable DHCP Support</b>	<p>Default = Off</p> <p>This option is not supported for use with Avaya IP DECT R4. The IP DECT base stations require DHCP and TFTP support. Enable this option if the system is being used to provide that support, using IP addresses from its DHCP range (LAN1 or LAN2) and its TFTP server setting. If not enabled, alternate DHCP and TFTP options must be provided during the IP DECT installation.</p> <ul style="list-style-type: none"> <li>• If it is desired to use the system for DHCP support of the ADMM and IP DECT base stations only, the system address range should be set to match that number of addresses. Those addresses are then taken during the system restart and will not be available for other DHCP responses following the restart.</li> <li>• For larger IP DECT installations, the use of a non-embedded TFTP software option other than Manager is recommended.</li> </ul>
<b>Boot File</b>	<p>Default = ADMM_RFP_1_0_0.tftp. Range = Up to 31 characters.</p> <p>The name and path of the ADMM software file. The path is relative to the TFTP server root directory.</p>
<b>ADMM MAC Address</b>	<p>Default = 00:00:00:00:00:00</p> <p>This field must be used to indicate the MAC address of the IP DECT base station that should load the ADMM software file and then act as the IP DECT system's ADMM. The address is entered in hexadecimal format using comma, dash, colon or period separators.</p>

*Table continues...*

Field	Description
<b>VLAN ID</b>	<p>Default = Blank. Range = 0 to 4095.</p> <p>If VLAN is being used by the IP DECT network, this field sets the VLAN address assigned to the base stations by the system if Enable DHCP Support is selected.</p> <ul style="list-style-type: none"> <li>• The system itself does not apply or use VLAN marking. It is assumed that the addition of VLAN marking and routing of VLAN traffic is performed by other switches within the customer network.</li> <li>• An ID of zero is not recommended for normal VLAN operation.</li> <li>• When blank, no VLAN option is sent to the IP DECT base station.</li> </ul>
<b>Base Station Address List</b>	<p>Default = Empty</p> <p>This box is used to list the MAC addresses of the IP DECT base stations, other than the base station being used as the ADMM and entered in the ADMM MAC Address field. Right-click on the list to select Add or Delete. or use the Insert and Delete keys. The addresses are entered in hexadecimal format using comma, dash, colon or period separators.</p>
<b>Enable Provisioning</b>	
<p>This option can be used with DECT R4 systems. It allows the setting of several values in the system configuration that previously needed to be set separately in the master base stations configuration. For full details refer to the DECT R4 Installation manual. The use of provisioning requires the system security settings to include an <b>IPDECT Group</b>.</p>	
<b>SARI/PARK</b>	<p>Default = 0</p> <p>Enter the PARK (Portable Access Rights Key) license key of the DECT R4 system. DECT handset users enter this key when subscribing to the DECT system.</p>
<b>Subscriptions</b>	<p>Default = Disabled</p> <p>Select the method of subscription supported for handsets subscribing to the DECT R4 system. The options are:</p> <ul style="list-style-type: none"> <li>• <b>Disabled:</b> Disables subscription of handsets.</li> <li>• <b>Auto-Create:</b> Allow anonymous subscription of handsets. Once subscribed, the handset is assigned a temporary extension number. That extension number can be confirmed by dialing *#. A new extension number can be specified by dialing &lt;Extension Number&gt;*&lt;Login Code&gt;#. The <b>Auto-Create Extension</b> and <b>Auto-Create User</b> settings above should also be enabled. While configured to this mode, Manager will not allow the manual addition of new IP DECT extensions.</li> <li>• <b>Preconfigured:</b> Allow subscription only against existing IP DECT extensions records in the system configuration. The handset IPEI number is used to match the subscribing handset to a system extension.</li> </ul>
<b>Authentication Code</b>	<p>Default = Blank.</p> <p>Set an authentication code that DECT handset users should enter when subscribing to the DECT system.</p>

Table continues...



Field	Description
<b>Enable Resiliency</b>	<p>Default = Off.</p> <p>Enables resiliency on the IP DECT Line. To configure resiliency, you must also configure an IP Office Line with <b>Backs up my IP Dect Phones</b> set to <b>On</b>.</p>
<b>Status Enquiry Period</b>	<p>Default = 30 seconds.</p> <p>The period between successive verifications on the H.323 channel. The smaller the interval, the faster the IP DECT system recognizes that IP Office is down.</p>
<b>Prioritize Primary</b>	<p>Default = Off.</p> <p>Only available when <b>Enable Provisioning</b> is set to <b>On</b>.</p> <p>Set to <b>On</b> for automatic fail-over recovery. When on, the IP DECT system switches automatically from the backup IP Office to the "primary" IP Office.</p> <p>Note that the IP DECT system does not switch back automatically from the backup IP Office to the primary. The IP DECT system must be manually switched using Web Manager.</p>
<b>Supervision Timeout</b>	<p>Default = 120 seconds.</p> <p>Only available when <b>Enable Provisioning</b> is set to <b>On</b>.</p> <p>The period of time the IP DECT system will wait between attempts to switch from the backup IP Office to its "primary" IP Office.</p>

### Related links

[IP DECT Line](#) on page 334

## VoIP

Navigation: **Line | IP DECT Line | VoIP**

Used to configure the VoIP setting applied to calls on the IP DECT line.

When creating an IP DECT line, these settings are mergeable. You can also remove an IP DECT line without rebooting. Changing an IP DECT line that has been imported into the configuration is not mergeable.

Field	Description
<b>Gateway IP Address</b>	<p>Default = Blank.</p> <p>Enter the IP address of the gateway device at the remote end. This address must not be shared by any other IP line (H.323, SIP, SES or IP DECT).</p>
<b>Standby IP Address</b>	<p>Default = Blank.</p> <p>IP Address of the Standby Master IP Base Station or the second Mirror Base Station. When the primary Mirror Base Station or Master Base Station is offline the second Mirror or the Standby Master will take over and the system will use this IP address.</p>

*Table continues...*

Field	Description
<p><b>Codec Selection</b></p>	<p>Default = System Default</p> <p>This field defines the codec or codecs offered during call setup. The available codecs in default preference order are:</p> <ul style="list-style-type: none"> <li>• <b>G.711 A-Law</b></li> <li>• <b>G.711 U-LAW</b></li> <li>• <b>G.729</b></li> <li>• <b>G.723.1</b></li> </ul> <p>Note that the default order for G.711 codecs varies to match the system's default companding setting. <b>G.723.1</b> is not supported on Linux based systems.</p> <p>The <b>G.722 64K</b> codec is also supported on IP500 V2 systems with IP500 VCM, IP500 VCM V2 or IP500 Combo cards. For Server Edition, it is supported on Primary Server, Secondary Server and Expansion System (L) systems and on Expansion System (V2) systems fitted with IP500 VCM, IP500 VCM V2 or IP500 Combo.</p> <p>The codecs available in this form are set through the codec list on <b>System   VoIP</b>.</p> <p>Within a network of systems, it is strongly recommended that all the systems and the lines connecting those systems use the same codecs.</p> <p>The options are:</p> <ul style="list-style-type: none"> <li>• <b>System Default</b> This is the default setting. When selected, the codec list below matches the codecs set in the system wide list.</li> <li>• <b>Custom</b> This option allows specific configuration of the codec preferences to be different from the system list. When <b>Custom</b> is selected, the list can be used to select which codecs are in the <b>Unused</b> list and in the <b>Selected</b> list and to change the order of the selected codecs.</li> </ul>
<p><b>TDM   IP Gain</b></p>	<p>Default = Default (0dB). Range = -31dB to +31dB.</p> <p>Allows adjustment of the gain on audio from the system TDM interface to the IP connection. This field is not shown on Linux based platforms.</p>
<p><b>IP   TDM Gain</b></p>	<p>Default = Default (0dB). Range = -31dB to +31dB.</p> <p>Allows adjustment of the gain on audio from the IP connection to the system TDM interface. This field is not shown on Linux based platforms.</p>
<p><b>VoIP Silence Suppression</b></p>	<p>Default = Off.</p> <p>When selected, this option will detect periods of silence on any call over the line and will not send any data during those silent periods. This feature is not used on IP lines using <b>G.711</b> between systems. On trunk's between networked systems, the same setting should be set at both ends.</p>

*Table continues...*

Field	Description
<b>Allow Direct Media Path</b>	<p>Default = On</p> <p>This settings controls whether IP calls must be routed via the system or can be routed alternatively if possible within the network structure.</p> <ul style="list-style-type: none"> <li>• If enabled, IP calls can take routes other than through the system, removing the need for system resources such as voice compression channels. Both ends of the calls must support Direct Media and have compatible VoIP settings such as matching codec, etc. If otherwise, the call will remain routed via the system. Enabling this option may cause some vendors problems with changing the media path mid call.</li> <li>• If disabled, the call is routed via the system. In that case, RTP relay support may still allow calls between devices using the same audio codec to not require a voice compression channel.</li> </ul>

### Related links

[IP DECT Line](#) on page 334

---

## SIP Line

IP Office supports SIP voice calls through the addition of SIP lines to the system configuration. This approach allows users with non-SIP phones to make and receive SIP calls.

Deleting a SIP line requires a “merge with service disruption”. When the configuration file is sent to the system, the SIP trunk is restarted and all calls on the line are dropped.

This type of configuration record can be saved as a template and new records created from a template. See [Working with Templates](#) on page 600.

### Related links

[Line](#) on page 279

[SIP Line](#) on page 339

[Transport](#) on page 343

[Call Details](#) on page 348

[VoIP](#) on page 360

[T38 Fax](#) on page 365

[SIP Credentials](#) on page 366

[SIP Advanced](#) on page 367

[Engineering](#) on page 372

## SIP Line

Navigation: [Line](#) | [SIP Line](#) | [SIP Line](#)

## Configuration Settings

These settings are mergeable with the exception of the **Line Number** setting. Changing the **Line Number** setting requires a “merge with service disruption”. When the configuration file is sent to the system, the SIP trunk is restarted and all calls on the line are dropped.

Field	Description
<b>Line Number</b>	<p>Default = Auto-filled. Range = 1 to 249 (<i>IP500 V2</i>)/349 (<i>Server Edition</i>).</p> <p>Enter the line number that you wish. Note that this must be unique. On IP500 V2 systems, line numbers 1 to 16 are reserved for internal hardware.</p>
<b>ITSP Domain Name</b>	<p>Default = Blank.</p> <p>This field is used to specify the default host part of the SIP URI in the From, To, and R-URI fields for outgoing calls. For example, in the SIP URI <code>name@example.com</code>, the host part of the URI is <code>example.com</code>. When empty, the default host is provided by the <b>SIP Line   SIP Transport   ITSP Proxy Address</b> field value. If multiple addresses are defined in the <b>ITSP Proxy Address</b> field, then this field must be defined.</p> <p>For the user making the call, the user part of the From SIP URI is determined by the settings of the SIP URI channel record being used to route the call (see <b>SIP Line   SIP URI   Local URI</b>). This will use one of the following:</p> <ul style="list-style-type: none"> <li>• a specific name entered in Local URI field of the channel record.</li> <li>• or specify using the primary or secondary authentication name set for the line below.</li> <li>• or specify using the SIP Name set for the user making the call (<b>User   SIP   SIP Name</b>).</li> </ul> <p>For the destination of the call, the user part of the To and R-URI fields are determined by dial short codes of the form <code>9N/N"@example.com</code> where N is the user part of the SIP URI and <code>"@example.com</code> is optional and can be used to override the host part of the To and R-URI.</p>
<b>Local Domain Name</b>	<p>Default = Blank.</p> <p>An IP address or SIP domain name as required by the service provider.</p> <p>When configured, the <b>Local Domain Name</b> value is used in</p> <ul style="list-style-type: none"> <li>• the <b>From</b> and <b>Contact</b> headers</li> <li>• the <b>PAI header</b>, when the setting <b>Line   SIP Line   Advanced   Use Domain for PAI</b> is checked</li> <li>• the <b>Diversion</b> header</li> </ul> <p>If both the <b>ITSP Domain Name</b> and the <b>Local Domain Name</b> are configured, then <b>Local Domain</b> takes precedence.</p> <p><b>Local Domain Name</b> is not used in the <b>Remote Party ID</b> header.</p>

*Table continues...*

Field	Description
<b>URI</b>	<p>Default = SIP.</p> <p>When SIP or SIPS is selected in the drop-down box, the SIP URI format is used (for example, name@example.com).</p> <p>When <b>Tel</b> is selected in the drop-down box, the Tel URI format is used (for example, +1-425-555-4567). This affects the From field of outgoing calls. The To field for outgoing calls will always use the format specified by the short codes used for outgoing call routing. Recommendation: When SIP Secured URI is required, the URI Type should be set to SIPS. SIPS can be used only when Layer 4 Protocol is set to TLS.</p>
<b>Location</b>	<p>Default = Cloud.</p> <p>Specify a location to associate the line with a physical location. Associating a line with a location:</p> <ul style="list-style-type: none"> <li>• Allows emergency services to identify the source of an emergency call.</li> <li>• Allows you to configure call admission control settings for the location.</li> </ul> <p>The drop down list contains all locations that have been defined in the <b>System   Location</b> form.</p>
<b>Prefix</b>	<p>Default = Blank.</p> <p>This prefix is removed from the called number on outgoing calls if present.</p>
<b>National Prefix</b>	<p>Default = 0.</p> <p>This prefix is added to calls identified as not being international.</p>
<b>International Prefix</b>	<p>Default = 00.</p> <p>This prefix is added to calls identified as not being national.</p>
<b>Country Code</b>	<p>Default = Blank.</p> <p>Set to match the local country code of the system location.</p>
<b>Name Priority</b>	<p>Default = System Default.</p> <p>For SIP trunks, the caller name displayed on an extension can either be that supplied by the trunk or one obtained by checking for a number match in the extension user's personal directory and the system directory. This setting determines which method is used by the line. The options are:</p> <ul style="list-style-type: none"> <li>• <b>System Default:</b> Use the system setting <b>System   Telephony   Telephony   Default Name Priority</b>.</li> <li>• <b>Favor Trunk:</b> Display the name provided by the trunk. For example, the trunk may be configured to provide the calling number or the name of the caller. The system should display the caller information as it is provided by the trunk. If the trunk does not provide a name, the system uses the <b>Favor Directory</b> method.</li> <li>• <b>Favor Directory:</b> Search for a number match in the extension user's personal directory and then in the system directory. The first match is used and overrides the name provided by the SIP line. If no match is found, the name provided by the line, if any, is used.</li> </ul>

*Table continues...*

Field	Description
<b>Description</b>	<p>Default = Blank. Maximum 31 characters.</p> <p>Use this field to enter a description of this configuration.</p>
<b>Network Type</b>	<p>Default = Public.</p> <p>This option is available if <b>System   Telephony   Telephony   Restrict Network Interconnect</b> is enabled. It allows the trunk to be set as either <b>Public</b> or <b>Private</b>. The system will return number busy indication to any attempt to connect a call on a <b>Private</b> trunk to a <b>Public</b> trunk or vice versa. This restriction includes transfers, forwarding and conference calls.</p> <p>Due to the nature of this feature, its use is not recommended on systems also using any of the following other system features: multi-site networks, VPNremote, application telecommuter mode.</p>
<b>In Service</b>	<p>Default = On.</p> <p>When this field is not selected, the SIP trunk is unregistered and not available to incoming and outgoing calls.</p>
<b>Check OOS</b>	<p>Default = On.</p> <p>If enabled, the system will regularly check if the trunk is in service using the methods listed below. Checking that SIP trunks are in service ensures that outgoing call routing is not delayed waiting for response on a SIP trunk that is not currently usable.</p> <p>For UDP and TCP trunks, OPTIONS message are regularly sent. If no reply to an OPTIONS message is received the trunk is taken out of service.</p> <p>For trunks using DNS, if the IP address is not resolved or the DNS resolution has expired, the trunk is taken out of service.</p>
<b>Session Timers</b>	
<b>Refresh Method</b>	<p>Default = Auto.</p> <p>The options are:</p> <ul style="list-style-type: none"> <li>• <b>Auto</b></li> <li>• <b>Reinvite</b></li> <li>• <b>Update</b></li> </ul> <p>When <b>Auto</b> is selected, if UPDATE is in the Allow: header from the far SIP endpoint, then it is used. Otherwise INVITE is used.</p>
<b>Timer (seconds)</b>	<p>Default = On Demand. Range = 90 to 64800</p> <p>This field specifies the session expiry time. At the half way point of the expiry time, a session refresh message is sent. When set to <b>On Demand</b>, IP Office will not send a session refresh message but will respond to them.</p>

*Table continues...*

Field	Description
<b>Redirect and Transfer</b>	<p>Redirection and blind transfer are configured separately. By default, they are disabled.</p> <p>A supervised transfer occurs when a consultation call is made and the REFER contains a Replaces: header indicating the CallID of another call leg which the REFERing agent has already initiated with the REFER target.</p> <p><b>* Note:</b> Do not change these settings unless directed to by the SIP service provider.</p>
<b>Incoming Supervised REFER</b>	<p>Default = Auto.</p> <p>Determines if IP Office will accept a REFER being sent by the far end. The options are:</p> <ul style="list-style-type: none"> <li>• <b>Always:</b> Always accepted.</li> <li>• <b>Auto:</b> If the far end does not advertise REFER support in the Allow: header of the OPTIONS responses, then IP Office will reject a REFER from that endpoint.</li> <li>• <b>Never:</b> Never accepted.</li> </ul>
<b>Outgoing Supervised REFER</b>	<p>Default = Auto.</p> <p>Determines if IP Office will attempt to use the REFER mechanism to transfer a party to a call leg which IP Office has already initiated so that it can include the CallID in a Replaces: header. The options are:</p> <ul style="list-style-type: none"> <li>• <b>Always:</b> Always use REFER.</li> <li>• <b>Auto:</b> Use the Allow: header of the OPTIONS response to determine if the endpoint supports REFER.</li> <li>• <b>Never:</b> Never use REFER.</li> </ul>
<b>Send 302 Moved Temporarily</b>	<p>Default = Off.</p> <p>A SIP response code used for redirecting an unanswered incoming call. It is a response to the INVITE, and cannot be used after the 200 OK has been sent as a response to the INVITE.</p>
<b>Outgoing Blind REFER</b>	<p>Default = Off.</p> <p>When enabled, a user, voicemail system or IVR can transfer a call by sending a REFER to an endpoint that has not set up a second call. In this case, there is no Replaces: header because there is no CallID to replace the current one. This directs the far end to perform the transfer by initiating the new call and release the current call with IP Office.</p>

### Related links

[SIP Line](#) on page 339

## Transport

Navigation: [Line](#) | [SIP Line](#) | [Transport](#)

## Behavior during Service unavailable

A proxy server is considered Active once the system has received a response to an INVITE, REGISTER or OPTIONS.

In the case of the proxy server responding with 503 - Service Unavailable, it should be considered Active - In Maintenance. In this case, the following should occur:

If the response 503 - Service Unavailable was in response to an INVITE request:

- If calls are tied to registrations (**Calls Route via Registrar** enabled) and there are other proxies available, the tied registrations should issue an Un-REGISTER and try to REGISTER with a different proxy. The call should fail with cause = Temporary Fail.
- If calls are not tied, the INVITE should be immediately tried to a different proxy.

If the response 503 - Service Unavailable was in response to a REGISTER request:

- If there are other proxies available, this registration only should issue an Un-REGISTER and try to REGISTER with a different proxy.
- If **Explicit DNS Server(s)** are configured, a DNS request should be sent out to see whether the proxy server has disappeared from those being offered.

An Active-InMaintenance proxy server should not be used for a new transactions (INVITE or REGISTER) until:

- There is a change in DNS responses indicating the proxy has become active.
- The configuration does not leave any better option available. In this case, there should be a throttle so that no more than 5 failures (without successes) in 1 minute should be allowed.
- A configuration merge has occurred where the ITSP Proxy Address has been changed.
- 10 minutes has expired.

## Behavior during Not Responding

A proxy server that is not-responding (UDP) is indicated when 3 requests are sent and no replies are received. This would normally occur during a single INVITE transaction.

Consideration should be given whether this is caused by a local network fault or is caused by the Proxy being out of service. Since it is likely to be local, no action should be taken unless traffic is received from an alternative proxy while this proxy is actually not responding. The state should be "Possibly non responding".

If explicit DNS servers are configured, a DNS request should be sent out to see whether this Proxy server has disappeared from those being offered.

If possible, an alternative proxy should be stimulated simultaneously with stimulating the suspect server.

The server should be considered non-responding if it is persistently non-responding while other proxies are responding or if it is non-responding and has disappeared from the DNS advertisement.

While in the "possibly not responding" state, it would be better to send an INVITE to an alternative proxy while simultaneously sending any appropriate message to this proxy. This will help to resolve whether it is really not responding rather than there being local network problems. However, there is no requirement to blacklist the proxy.



Once in the "definitely not responding" state:

- If there are other proxies available: this registration only issues an Un-REGISTER, and try to REGISTER with a different proxy. Calls do not automatically clear.
- If a SIP message is received from it, the state should immediately go "Active".
- This proxy should be blacklisted unless there are no better options available. While blacklisted, only one transaction per 10 minutes is allowed.
- Even if not blacklisted, there should be a throttle so that no more than 5 failures (without successes) in 1 minute should be allowed.

### **Configuration settings**

The **ITSP Proxy Address** and **Calls Route via Registrar** settings are mergeable. Changing the remaining settings requires a "merge with service disruption". When the configuration file is sent to the system, the SIP trunk is restarted and all calls on the line are dropped.

Field	Description
<p><b>ITSP Proxy Address</b></p>	<p>Default = Blank</p> <p>This is the SIP Proxy address used for outgoing SIP calls. The address can be specified in the following ways:</p> <ul style="list-style-type: none"> <li>• If left blank, the ITSP Domain Name is used and is resolved by DNS resolution in the same way as if a DNS address had been specified as below.</li> <li>• An IP address.</li> <li>• A list of up to 4 IP addresses, with each address separated by a comma or space.                             <ul style="list-style-type: none"> <li>- The addresses can include an indication of the relative call weighting of each address compared to the others. This is done by adding a <b>w N</b> suffix to the address where <b>N</b> is the weighting value. For example, in the list 213.74.81.102w3 213.74.81.100w2, the weighting values assigns 1.5 times the weight of calls to the first address. The default weight if not specified is 1. A weight of 0 can be used to disable an address. Weight is only applied to outgoing calls.</li> </ul> </li> </ul> <p>If there is more than one proxy defined, and no weight indication, then calls are only sent to the first in the list until there is a failure at which point the next proxy is used.</p> <ul style="list-style-type: none"> <li>- If the <b>Calls Route via Registrar</b> setting below is enabled, the weighting is applied to registrations rather than calls.</li> </ul> <ul style="list-style-type: none"> <li>• A DNS address, for example sbc.example.com.                             <ul style="list-style-type: none"> <li>- The DNS response may return multiple proxy addresses (RFC 3263). If that is the case, the system will resolve the address to use based on priority, TTL and weighting information included with each address.</li> <li>- A load balancing suffix can be added to specify that multiple proxy results should be returned if possible, for example sbc.example.com(N). where <b>N</b> is the required number of addresses from 1 to 4.</li> </ul> </li> </ul> <p>This field is mergeable. However, no more than 4 IP Addresses should be in use at any time. So, if the combined new and old address settings exceed 4, the new addresses are only phased into use as transactions in progress on the previous addresses are completed.</p>
<p><b>Network Configuration</b></p>	

*Table continues...*

Field	Description
<b>Layer 4 Protocol</b>	<p>Default = UDP.</p> <p>The options are:</p> <ul style="list-style-type: none"> <li>• <b>TCP</b></li> <li>• <b>UDP</b></li> <li>• <b>TLS</b></li> <li>• <b>Auto</b></li> </ul> <p>TLS connections support the following ciphers:</p> <ul style="list-style-type: none"> <li>• TLS_RSA_WITH_AES_128_CBC_SHA</li> <li>• TLS_RSA_WITH_AES_256_CBC_SHA</li> <li>• TLS_DHE_RSA_WITH_AES_128_CBC_SHA</li> <li>• TLS_DHE_RSA_WITH_AES_256_CBC_SHA</li> </ul>
<b>Use Network Topology Info</b>	<p>Default = None.</p> <p>This field associates the SIP line with the LAN interface <b>System   LAN   Network Topology</b> settings. It also applies the <b>System   LAN   VoIP   DiffServ Settings</b> to the outgoing traffic on the SIP line. If <b>None</b> is selected, STUN lookup is not applied and routing is determined by the system's routing tables.</p> <p>If no STUN server address is set for the interface, then the <b>System   LAN   Network Topology   Binding Refresh Time</b> is ignored by SIP Lines when calculating the periodic OPTIONS timing unless the <b>Firewall/NAT Type</b> is set to <b>Open Internet</b>.</p>
<b>Send Port</b>	When Network Configuration is set to TLS, the default setting is 5061. When Network Configuration is set to TCP or UDP, the default setting is 5060.
<b>Listen Port</b>	When Network Configuration is set to TLS, the default setting is 5061. When Network Configuration is set to TCP or UDP, the default setting is 5060.
<b>Explicit DNS Server(s)</b>	<p>Default = 0.0.0.0 (Off)</p> <p>If specific DNS servers should be used for SIP trunk operation rather than the general DNS server specified or obtained for the system, the server addresses can be specified here. If exported or imported as part of a trunk template.</p>
<b>Calls Route via Registrar</b>	<p>Default = On</p> <p>If selected, all calls are routed via the same proxy as used for registration. If multiple ITSP proxy addresses have been specified, there is no load balancing of registrations.</p>
<b>Separate Registrar</b>	<p>Default = Blank</p> <p>This field allows the SIP registrar address to be specified if it is different from that of the SIP proxy. The address can be specified as an IP address or DNS name.</p>

#### Related links

[SIP Line](#) on page 339

## Call Details

Navigation: [Line](#) | [SIP Line](#) | [Call Details](#)

### SIP URI

Having set up the SIP trunk to the SIP ITSP, the SIP URI's registered with that ITSP are entered on this tab. A SIP URI (Uniform Resource Identifier) is similar to an internet email address and represents the source or destination for SIP connection. The URI consists of two parts, the user part (name) and the host part (example.com).

SIP URI records are used to describe content of SIP headers when working with various ITSPs, since they use these SIP headers for various purposes and match them to IP Office interpretation of these headers. For incoming calls, headers in the SIP message must match the headers described in the appropriate URI. For outgoing calls, IP Office internal displays and calling or called numbers are mapped to appropriate headers in a way provider expects them to be formatted.

If the **Auto** setting is used in the SIP trunk's **Local URI**, **Contact** and **Display** fields, that SIP trunk will accept any incoming SIP call. The incoming call routing is still performed by the system incoming call routes based on matching the values received with the call or the URI's incoming group setting. On outgoing calls, **Auto** passes the calling and called party numbers from IP Office call unchanged to the SIP provider. The **Auto** setting has replaced the wildcard \* used in previous releases.

For outgoing calls using this SIP URI, all valid short code CLI manipulations are used (transforming calling party number to ISDN will be ignored). For a full list of valid CLI manipulations, see "Telephone Number Field Characters" in the chapter "Short Code Overview". For example, character 'i' is not supported since it sets calling party number plan to isdn and number type to national.

For the system, each SIP URI acts as a set of trunk channels. Outgoing calls can then be routed to the required URI by short codes that match that URI's **Outgoing Group** setting. Incoming calls can be routed by incoming call routes that match the URI's **Incoming Group** setting.

Note that the system supports only up to 150 URI records on a SIP line.

### SIP Line Appearances

Using this feature, Line appearances can be configured on phones that support Line appearances. Several Line appearances can be associated with one SIP Line, specified by an ITSP. The buttons can be used to make or receive calls. ITSPs specify how many calls can be made or received using a particular SIP number.

If a SIP number can be used to make "n" number of calls, the system allocates "n" system wide unique line appearances for that number. All phones that wish to use the Line Appearance to make or receive calls must have a line appearance button configured to point to that Line ID. A SIP number can be accessed through the Line Appearance to make calls, answer calls, or conference with other users already on the call. Lamps on the button indicate whether the number is in use.

In case a sip number can be used to make or receive three calls, system can be configured to associate that number with three Line Appearance IDs. For simplicity purposes, Line Appearance IDs should be consecutive (for example 700, 701, 702...). The direction of call allocation can also be configured. The preferred way of configuring for outgoing calls and incoming calls are reverse

of each other to avoid confusion. For example, if the outgoing calls are allocated from 700->702, the incoming calls are allocated from 702->700.

SIP line appearances are supported on all phones that support line appearances. They are not supported over SCN or in resiliency.

### Related links

[SIP Line](#) on page 339

[SIP URI](#) on page 349

[SIP Line Appearances](#) on page 356

### SIP URI

Name	Description
<b>URI</b>	This field is for information only and cannot be edited. It shows the IP address of the system LAN interface with which the SIP trunk is associated.
<b>Incoming Group</b>	Default = 0, Range 0 to 99999.  The Incoming Group ID to which a line belongs is used to match it to incoming call routes in the system configuration. The matching incoming call route is then used to route incoming calls. The same ID can be used for multiple lines.
<b>Outgoing Group</b>	Default = Previous external line + 1, Range 0 to 99999.  Short codes that specify a number to dial can also specify the line group to be used. The system will then seize a line from those with the matching Outgoing Group ID.  In a Server Edition network, the <b>Outgoing Group ID</b> used must be unique within the network. The same ID cannot be used in the configuration of any lines on another server system in the network. For non-Server Edition deployments, the same ID can be used for multiple lines.  <b>Reserved Group ID Numbers:</b> <ul style="list-style-type: none"> <li>• <b>90000 - 99999</b> Reserved for system use (not enforced).</li> <li>• <b>99999 and 99998</b> In a Server Edition network, reserved for the IP Office lines to the Primary Server and Secondary Server respectively.</li> <li>• <b>99901 to 99930</b> In a Server Edition network, reserved for the IP Office lines from the Primary Server to each expansion system in the network.</li> <li>• <b>0</b> In a Server Edition network, the ID 0 cannot be used.</li> <li>• <b>98888</b> For IP Office deployed in an Enterprise Branch environment, reserved for the SM line.</li> </ul>
<b>Max Sessions</b>	Default =10 This field sets the maximum number of simultaneous calls that can use the URI before the system returns busy to any further calls. For capacity information, see <i>Deploying Avaya IP Office™ Platform Server Edition</i> .
<b>Credentials</b>	Default = 0:<None>  This field is used to select from a list of the account credentials configured on the line's <b>SIP Credentials</b> tab.

*Table continues...*

Name	Description
<b>Local URI:</b>	<p>This field sets the 'From' field for outgoing SIP calls using this URI.</p> <ul style="list-style-type: none"> <li>• <b>Display:</b> This field sets the Name value for outgoing SIP calls using this URI.</li> <li>• <b>Content:</b> This field sets the Content of SIP headers for outgoing SIP calls using this URI. The values you type in the Content field are also reflected in the Display field.</li> <li>• <b>Outgoing Calls:</b> Default = Caller. You can select any one of the following options: <ul style="list-style-type: none"> <li>- Caller</li> <li>- Explicit</li> <li>- None</li> </ul> </li> <li>• <b>Forwarding/Twinning:</b> Default = Caller. This column sets the source used for the system's SIP URIs with incoming calls that it then redirects as outgoing calls. For example, calls it forwards or twins for users. You can select any one of the following options: <ul style="list-style-type: none"> <li>- Caller: Use the name and number of the user or device forwarding the call.</li> <li>- Explicit: Use the values manually typed in the <b>Display</b> and <b>Content</b> columns.</li> <li>- Original Caller: Use the name and number details of the original caller who is now being forwarded. Note that use of this value form some headers such as P-Asserted-ID and P-Preferred-ID may not be supported if the line provider requires the caller information to be present in that header for billing purposes.</li> </ul> </li> <li>• <b>Incoming Calls:</b> Default = Called. This column sets the source for the value used to match incoming calls from the line provider. You can select any one of the following options: <ul style="list-style-type: none"> <li>- Called: Use the automatically determined settings appropriate to the call destination.</li> <li>- Explicit: Use the values manually typed in the <b>Display</b> and <b>Content</b> columns as intended destination.</li> <li>- None: Do not send the header.</li> </ul> </li> </ul>

*Table continues...*

Name	Description
<b>Contact</b>	<p>This field sets the From field for outgoing SIP calls using this URI.</p> <ul style="list-style-type: none"> <li>• <b>Display:</b> This configurable field sets the Name value for outgoing SIP calls using this URI.</li> <li>• <b>Content:</b> This configurable field sets the Content of SIP headers for outgoing SIP calls using this URI. The values you type in the Content field are also reflected in the Display field.</li> <li>• <b>Outgoing Calls:</b> Default = Caller. You can select any one of the following options: <ul style="list-style-type: none"> <li>- Caller</li> <li>- Explicit</li> <li>- None</li> </ul> </li> <li>• <b>Forwarding/Twinning:</b> Default = Caller. This field can be used to set an originator number for forwarded and twinned calls. You can select any one of the following options: <ul style="list-style-type: none"> <li>- Caller</li> <li>- Explicit</li> <li>- Original Caller</li> </ul> </li> <li>• <b>Incoming Calls:</b> Default = Called. You can select any one of the following options: <ul style="list-style-type: none"> <li>- Called</li> <li>- Explicit</li> <li>- None</li> </ul> </li> </ul>

*Table continues...*

Name	Description
<b>P. Asserted ID</b>	<p>Default = Disabled</p> <p>When selected, identity information is provided in the P Asserted Identity header of SIP messages. You can enable P-Asserted-Identity (PAI) headers to assert the identity of users in outgoing SIP requests or response messages.</p> <ul style="list-style-type: none"> <li>• <b>Display:</b> This configurable field sets the Name value for outgoing SIP calls using this URI.</li> <li>• <b>Content:</b> This configurable field sets the Content of SIP headers for outgoing SIP calls using this URI. The values you type in the Content field are also reflected in the Display field.</li> <li>• <b>Outgoing Calls:</b> Default = Caller. You can select any one of the following options: <ul style="list-style-type: none"> <li>- Caller</li> <li>- Explicit</li> <li>- None</li> </ul> </li> <li>• <b>Forwarding/Twinning:</b> Default = Original Caller. This field can be used to set an originator number for forwarded and twinned calls. You can select any one of the following options: <ul style="list-style-type: none"> <li>- Caller</li> <li>- Explicit</li> <li>- Original Caller</li> </ul> </li> <li>• <b>Incoming Calls:</b> Default = Called. You can select any one of the following options: <ul style="list-style-type: none"> <li>- Called</li> <li>- Explicit</li> <li>- None</li> </ul> </li> </ul>

*Table continues...*



Name	Description
<b>P Preferred ID:</b>	<p>Default = Disabled</p> <p>When selected, identity information is provided in the P Preferred Identity header of SIP messages.</p> <ul style="list-style-type: none"> <li>• <b>Display:</b> This configurable field sets the Name field for outgoing SIP calls using this URI.</li> <li>• <b>Content:</b> This configurable field sets the Content of SIP headers for outgoing SIP calls using this URI. The values you type in the Content field are also reflected in the Display field.</li> <li>• <b>Outgoing Calls:</b> Default = Caller. You can select any one of the following options: <ul style="list-style-type: none"> <li>- Called</li> <li>- Explicit</li> <li>- None</li> </ul> </li> <li>• <b>Forwarding/Twinning:</b> Default = Original Caller <p>This field can be used to set an originator number for forwarded and twinned calls. You can select any one of the following options:</p> <ul style="list-style-type: none"> <li>- Caller</li> <li>- Explicit</li> <li>- None</li> <li>- Original Caller</li> </ul> </li> <li>• <b>Incoming Calls:</b> Default = Called. You can select any one of the following options: <ul style="list-style-type: none"> <li>- Called</li> <li>- Explicit</li> <li>- None</li> </ul> </li> </ul>

*Table continues...*

Name	Description
<b>Diversion Header</b>	<p>Default = Disabled</p> <p>When selected, information from the Diversion Header is provided in the SIP messages.</p> <ul style="list-style-type: none"> <li>• <b>Display:</b> This configurable field sets the Name field for outgoing SIP calls using this URI.</li> <li>• <b>Content:</b> This configurable field sets the Content of SIP headers for outgoing SIP calls using this URI. The values you type in the Content field are also reflected in the Display field.</li> <li>• <b>Outgoing Calls:</b> Default = Caller. You can select any one of the following options: <ul style="list-style-type: none"> <li>- Caller</li> <li>- Explicit</li> <li>- None</li> </ul> </li> <li>• <b>Forwarding/Twinning:</b> Default = Caller. This field can be used to set an originator number for forwarded and twinned calls. You can select any one of the following options: <ul style="list-style-type: none"> <li>- Caller</li> <li>- Explicit</li> <li>- None</li> <li>- Original Caller</li> </ul> </li> <li>• <b>Incoming Calls:</b> Default = None.</li> </ul>

*Table continues...*

Name	Description
<b>Remote Party ID</b>	<p>Default = Disabled</p> <p>When selected, it sets up the Remote Party ID header. the Diversion header for outgoing SIP calls using this URI.</p> <ul style="list-style-type: none"> <li>• <b>Display:</b> This configurable field sets the Name value for outgoing SIP calls using this URI.</li> <li>• <b>Content:</b> This configurable field sets the Content of SIP headers for outgoing SIP calls using this URI. The values you type in the Content field are also reflected in the Display field.</li> <li>• <b>Outgoing Calls:</b> Default = Caller. You can select any one of the following options: <ul style="list-style-type: none"> <li>- Caller</li> <li>- Explicit</li> <li>- None</li> </ul> </li> <li>• <b>Forwarding/Twinning:</b> Default = Original Caller. This field can be used to set an originator number for forwarded and twinned calls. You can select any one of the following options: <ul style="list-style-type: none"> <li>- Caller</li> <li>- Explicit</li> <li>- None</li> <li>- Original Caller</li> </ul> </li> <li>• <b>Incoming Calls:</b> Default = Called. You can select any one of the following options: <ul style="list-style-type: none"> <li>- Called</li> <li>- Explicit</li> <li>- None</li> </ul> </li> </ul>

Display and Content fields are configurable for each SIP header separately. The value can either be entered manually or one of the following options can be selected:

- **Auto:** Use the number that IP Office is using to make the call as the From field. The number will be aligned with IP Office internal numbering schema.
- **Use Internal Data:** Use the value **User | SIP | Display Name (Alias)** for the user making the call.

The system can also use

- **Group | SIP | SIP Display Name (Alias)** for a group
- **System | Voicemail | SIP Display Name (Alias)** for voicemail

If you have selected a Credential value other than None, the following options become available in the drop-down list for you to select:

- **Credentials User Name:** Use the value **Line | SIP Line | SIP Credentials | User Name** for the user making the call.

- Credentials Authentication Name: Use the value **Line | SIP Line | SIP Credentials | Authentication Name**.
- Credentials Contact: Use the value **Line | SIP Line | SIP Credentials | Contact**.

**Related links**

[Call Details](#) on page 348

**SIP Line Appearances**

Name	Description
<b>SIP Line Appearances</b>	Default = Disabled  When enabled, the content of the pane is displayed at the bottom half of the page. You can use the Add, Edit, and Delete options to configure SIP Line Appearances parameters. If you disable the SIP Line Appearances check box and save the configuration, all the configured values are lost.
<b>Incoming Group</b>	Default = 0, Range 0 to 99999.  The Incoming Group ID to which a line belongs is used to match it to incoming call routes in the system configuration. The matching incoming call route is then used to route incoming calls. The same ID can be used for multiple lines.
<b>Outgoing Group</b>	Default = Previous external line + 1, Range 0 to 99999.  Short codes that specify a number to dial can also specify the line group to be used. The system will then seize a line from those with the matching Outgoing Group ID.  In a Server Edition network, the <b>Outgoing Group ID</b> used must be unique within the network. The same ID cannot be used in the configuration of any lines on another server system in the network. For non-Server Edition deployments, the same ID can be used for multiple lines.  <b>Reserved Group ID Numbers:</b> <ul style="list-style-type: none"> <li>• <b>90000 - 99999</b> Reserved for system use (not enforced).</li> <li>• <b>99999 and 99998</b> In a Server Edition network, reserved for the IP Office lines to the Primary Server and Secondary Server respectively.</li> <li>• <b>99901 to 99930</b> In a Server Edition network, reserved for the IP Office lines from the Primary Server to each expansion system in the network.</li> <li>• <b>0</b> In a Server Edition network, the ID 0 cannot be used.</li> <li>• <b>98888</b> For IP Office deployed in an Enterprise Branch environment, reserved for the SM line.</li> </ul>
<b>Credentials</b>	Default = 0:<None>  This field is used to select from a list of the account credentials configured on the line's <b>SIP Credentials</b> tab.
<b>Max Sessions</b>	Default =10 This field sets the maximum number of simultaneous calls that can use the URI before the system returns busy to any further calls. For capacity information, see <i>Deploying Avaya IP Office™ Platform Server Edition</i> .

*Table continues...*

Name	Description
<b>Incoming Sessions</b>	Default = 3 The number of Incoming call sessions. The range varies from 0 to Max Sessions. If you change the Max Sessions, the number of Incoming sessions are automatically updated to reflect the change.
<b>Outgoing Sessions</b>	Default = 3 The number of Outgoing call sessions. The range varies from 0 to Max Sessions. If you change the Max Sessions, the number of Outgoing sessions are automatically updated to reflect the change.
<b>Line Appearance ID</b>	Default = 701 The Line Appearance ID is a representation of the SIP trunk line on the IP Office system. The indicator corresponding to the Line Appearance indicates the activities on the line.
<b>Incoming ID</b>	The ID on which the Incoming call activities are indicated. The range of the IDs are from maximum to minimum and changes when the Max Sessions values are updated.
<b>Outgoing ID</b>	The ID on which the Outgoing call activities are indicated. This is a read-only field. The range of the IDs are from minimum to maximum and changes when the Max Sessions values are updated.
<b>Local URI</b>	This field sets the 'From' field for outgoing SIP calls using this SIP Line. <ul style="list-style-type: none"> <li>• <b>Display:</b> This configurable field sets the Name value for outgoing SIP calls using this SIP Line.</li> <li>• <b>Content:</b> This field sets the Content of SIP headers for outgoing SIP calls using this SIP Line. The values you type in the Content field are also reflected in the Display field.</li> <li>• <b>Outgoing Calls:</b> Default = Explicit.</li> <li>• <b>Incoming Calls:</b> Default = Explicit.</li> </ul>

*Table continues...*

Name	Description
<b>Contact</b>	<p>This field sets the From field for outgoing SIP calls using this SIP Line.</p> <ul style="list-style-type: none"> <li>• <b>Display:</b> This configurable field sets the Name value for outgoing SIP calls using this SIP Line.</li> <li>• <b>Content:</b> This field sets the Content of SIP headers for outgoing SIP calls using this SIP Line. The values you type in the Content field are also reflected in the Display field.</li> <li>• <b>Outgoing Calls:</b> Default = Explicit. You can select any one of the following options: <ul style="list-style-type: none"> <li>- Explicit</li> <li>- None</li> </ul> </li> <li>• <b>Incoming Calls:</b> Default = Explicit. You can select any one of the following options: <ul style="list-style-type: none"> <li>- Explicit</li> <li>- None</li> </ul> </li> </ul>
<b>P Asserted ID</b>	<p>Default = Disabled</p> <p>When selected, identity information is provided in the P Asserted Identity header of SIP messages. You can enable P-Asserted-Identity (PAI) headers to assert the identity of users in outgoing SIP requests or response messages.</p> <p> <b>Note:</b></p> <p>You can enter the wildcard character “*”. Entering this value populates the SIP PAI header with the caller information available to IP Office.</p> <ul style="list-style-type: none"> <li>• <b>Display:</b> This configurable field sets the Name value for outgoing SIP calls using this SIP Line.</li> <li>• <b>Content:</b> This field sets the Content of SIP headers for outgoing SIP calls using this SIP Line. The values you type in the Content field are also reflected in the Display field.</li> <li>• <b>Outgoing Calls:</b> Default = Explicit. You can select any one of the following options: <ul style="list-style-type: none"> <li>- Explicit</li> <li>- None</li> </ul> </li> <li>• <b>Incoming Calls:</b> Default = Explicit. You can select any one of the following options: <ul style="list-style-type: none"> <li>- Explicit</li> <li>- None</li> </ul> </li> </ul>

*Table continues...*

Name	Description
<b>P Preferred ID</b>	<p>Default = Disabled</p> <p>When selected, identity information is provided in the P Preferred Identity header of SIP messages.</p> <ul style="list-style-type: none"> <li>• <b>Display:</b> This configurable field sets the Name value for outgoing SIP calls using this SIP Line.</li> <li>• <b>Content:</b> This field sets the Content of SIP headers for outgoing SIP calls using this SIP Line. The values you type in the Content field are also reflected in the Display field.</li> <li>• <b>Outgoing Calls:</b> Default = Explicit. You can select any one of the following options: <ul style="list-style-type: none"> <li>- Explicit</li> <li>- None</li> </ul> </li> <li>• <b>Incoming Calls:</b> Default = Explicit. You can select any one of the following options: <ul style="list-style-type: none"> <li>- Explicit</li> <li>- None</li> </ul> </li> </ul>
<b>Diversion Header</b>	<p>Default = Disabled</p> <p>When selected, information from the Diversion Header is provided in the SIP messages.</p> <ul style="list-style-type: none"> <li>• <b>Display:</b> This configurable field sets the Name value for outgoing SIP calls using this SIP Line.</li> <li>• <b>Content:</b> This field sets the Content of SIP headers for outgoing SIP calls using this SIP Line. The values you type in the Content field are also reflected in the Display field.</li> <li>• <b>Outgoing Calls:</b> Default = Explicit. You can select any one of the following options: <ul style="list-style-type: none"> <li>- Explicit</li> <li>- None</li> </ul> </li> <li>• <b>Incoming Calls:</b> Default = None.</li> </ul>

*Table continues...*

Name	Description
<b>Remote Party ID</b>	<p>Default = Disabled</p> <p>When selected, it sets up the Remote Party ID header. the Diversion header for outgoing SIP calls using this URI.</p> <p>.</p> <ul style="list-style-type: none"> <li>• <b>Display:</b> This configurable field sets the Name value for outgoing SIP calls using this SIP Line.</li> <li>• <b>Content:</b> This field sets the Content of SIP headers for outgoing SIP calls using this SIP Line. The values you type in the Content field are also reflected in the Display field.</li> <li>• <b>Outgoing Calls:</b> Default = Explicit. You can select any one of the following options: <ul style="list-style-type: none"> <li>- Explicit</li> <li>- None</li> </ul> </li> <li>• <b>Incoming Calls:</b> Default = Explicit. You can select any one of the following options: <ul style="list-style-type: none"> <li>- Explicit</li> <li>- None</li> </ul> </li> </ul>

Display and Content fields are configurable for each SIP header separately. The value can either be entered manually or one of the following options can be selected:

- **Auto:** Use the number that IP Office is using to make the call as the From field. The number will be aligned with IP Office internal numbering schema.
- **Use Internal Data:** Use the value **User | SIP | Display Name (Alias)** for the user making the call.

The system can also use

- **Group | SIP | SIP Display Name (Alias)** for a group
- **System | Voicemail | SIP Display Name (Alias)** for voicemail

If you have selected a Credential value other than None, the following options become available in the drop-down list for you to select:

- **Credentials User Name:** Use the value **Line | SIP Line | SIP Credentials | User Name** for the user making the call.
- **Credentials Authentication Name:** Use the value **Line | SIP Line | SIP Credentials | Authentication Name**.
- **Credentials Contact:** Use the value **Line | SIP Line | SIP Credentials | Contact**.

**Related links**

[Call Details](#) on page 348

**VoIP**

Navigation: **Line | SIP Line | VoIP**



This form is used to configure the VoIP settings applied to calls on the SIP trunk.

## Configuration Settings

These settings are mergeable. Changes to these settings do not require a reboot of the system.

Field	Description
<b>Codec Selection</b>	<p>Default = System Default</p> <p>This field defines the codec or codecs offered during call setup. The available codecs in default preference order are:</p> <ul style="list-style-type: none"> <li>• <b>G.711 A-Law</b></li> <li>• <b>G.711 U-LAW</b></li> <li>• <b>G.729</b></li> <li>• <b>G.723.1</b></li> </ul> <p>Note that the default order for G.711 codecs varies to match the system's default companding setting. <b>G.723.1</b> is not supported on Linux based systems.</p> <p>The <b>G.722 64K</b> codec is also supported on IP500 V2 systems with IP500 VCM, IP500 VCM V2 or IP500 Combo cards. For Server Edition, it is supported on Primary Server, Secondary Server and Expansion System (L) systems and on Expansion System (V2) systems fitted with IP500 VCM, IP500 VCM V2 or IP500 Combo.</p> <p>The codecs available in this form are set through the codec list on <b>System   VoIP</b>.</p> <p>Within a network of systems, it is strongly recommended that all the systems and the lines connecting those systems use the same codecs.</p> <p>The options are:</p> <ul style="list-style-type: none"> <li>• <b>System Default</b> This is the default setting. When selected, the codec list below matches the codecs set in the system wide list.</li> <li>• <b>Custom</b> This option allows specific configuration of the codec preferences to be different from the system list. When <b>Custom</b> is selected, the list can be used to select which codecs are in the <b>Unused</b> list and in the <b>Selected</b> list and to change the order of the selected codecs.</li> </ul>

*Table continues...*

Field	Description
<p><b>Fax Transport Support</b></p>	<p>Default = Off.</p> <p>This option is only available if <b>Re-Invite Supported</b> is selected.</p> <p>IP500 V2 systems can terminate T38 fax calls. IP Office Linux systems can route the calls between trunks/terminals with compatible fax types. If the media is routed by IP Office between trunks/terminals with incompatible fax types or if fax is terminated by IP Office, IP Office will detect fax tones and renegotiate the call as needed.</p> <p>This setting must be configured based on what is supported by the SIP ATA. The options are:</p> <ul style="list-style-type: none"> <li>• <b>None</b> Select this option if fax is not supported by the line provider.</li> <li>• <b>G.711</b> G.711 is used for the sending and receiving of faxes.</li> <li>• <b>T38</b> T38 is used for the sending and receiving of faxes.</li> <li>• <b>T38 Fallback</b> When you enable this option, T38 is used for sending and receiving faxes on a SIP line. If the called destination does not support T38, the system will send a re-invite to change the transport method to G.711.</li> </ul>
<p><b>DTMF Support</b></p>	<p>Default = RFC2833.</p> <p>This setting is used to select the method by which DTMF key presses are signalled to the remote end. The options are:</p> <ul style="list-style-type: none"> <li>• <b>In Band:</b> Send DTMF digits as part of the audio path.</li> <li>• <b>RFC2833:</b> Send DTMF digits using a separate audio stream from the voice path. Note that use of RFC2833 is negotiated with the remote end of the call. If not agreed or not supported, the line reverts to using in band signalling.</li> <li>• <b>Info:</b> Send the DTMF digits in SIP INFO packets.</li> </ul>
<p><b>Media Security</b></p>	<p>Default = Disabled.</p> <p>These setting control whether SRTP is used for this line and the settings used for the SRTP. The options are:</p> <ul style="list-style-type: none"> <li>• <b>Same as System:</b> Matches the system setting at <b>System   VoIP Security</b>.</li> <li>• <b>Disabled:</b> Media security is not required. All media sessions (audio, video, and data) will be enforced to use RTP only.</li> <li>• <b>Preferred:</b> Media security is preferred. Attempt to use secure media first and if unsuccessful, fall back to non-secure media.</li> <li>• <b>Enforced:</b> Media security is required. All media sessions (audio, video, and data) will be enforced to use SRTP only.</li> </ul> <p> <b>Warning:</b></p> <p>Selecting <b>Enforced</b> on a line or extension that does not support media security will result in media setup failures.</p>

*Table continues...*

Field	Description
<b>Advanced Media Security Options</b>	<p>Not displayed if <b>Media Security</b> is set to <b>Disabled</b>. The options are:</p> <ul style="list-style-type: none"> <li>• <b>Same as System:</b> Use the same settings as the system setting configured on <b>System   VoIP Security</b>.</li> <li>• <b>Encryptions:</b> Default = RTP This setting allows selection of which parts of a media session should be protected using encryption. The default is to encrypt just the RTP stream (the speech).</li> <li>• <b>Authentication:</b> Default = RTP and RTCP This setting allows selection of which parts of the media session should be protected using authentication.</li> <li>• <b>Replay Protection SRTP Window Size:</b> Default = 64. Currently not adjustable.</li> <li>• <b>Crypto Suites:</b> Default = SRTP_AES_CM_128_SHA1_80. There is also the option to select SRTP_AES_CM_128_SHA1_32.</li> </ul>
<b>VoIP Silence Suppression</b>	<p>Default = Off</p> <p>When selected, this option will detect periods of silence on any call over the line and will not send any data during those silent periods. This feature is not used on IP lines using <b>G.711</b> between systems. On trunks between networked systems, the same setting should be set at both ends.</p>
<b>Local Hold Music</b>	<p>Default = Off.</p> <p>When enabled, if the far end puts the call on HOLD, the system plays music received from far end (SIP Line) to the other end. RTCP reports are sent towards SIP Line. When disabled, the system plays local music to the other endpoint and no RTCP packets are sent to SIP trunk.</p>
<b>Re-Invite Supported</b>	<p>Default = Off.</p> <p>When enabled, <b>Re-Invite</b> can be used during a session to change the characteristics of the session. For example when the target of an incoming call or a transfer does not support the codec originally negotiated on the trunk. Requires the ITSP to also support <b>Re-Invite</b>. This setting must be enabled for video support.</p>
<b>Codec Lockdown</b>	<p>Default = Off.</p> <p>Supports RFC 3264 Section 10.2 when <b>RE-Invite Supported</b> is enabled. In response to a SIP offer with a list of codecs supported, some SIP user agents supply a SDP answer that also lists multiple codecs. This means that the user agent may switch to any of those codecs during the session without further negotiation. The system does not support multiple concurrent codecs for a session, so loss of speech path will occur if the codec is changed during the session. If codec lockdown is enabled, when the system receives an SDP answer with more than one codec from the list of offered codecs, it sends an extra re-INVITE using just a single codec from the list and resubmits a new SDP offer with just the single chosen codec.</p>

*Table continues...*

Field	Description
<b>Allow Direct Media Path</b>	<p>Default = On</p> <p>This settings controls whether IP calls must be routed via the system or can be routed alternatively if possible within the network structure.</p> <ul style="list-style-type: none"> <li>• If enabled, IP calls can take routes other than through the system, removing the need for system resources such as voice compression channels. Both ends of the calls must support Direct Media and have compatible VoIP settings such as matching codec, etc. If otherwise, the call will remain routed via the system. Enabling this option may cause some vendors problems with changing the media path mid call.</li> <li>• If disabled, the call is routed via the system. In that case, RTP relay support may still allow calls between devices using the same audio codec to not require a voice compression channel.</li> </ul>
<b>PRACK/100rel Supported</b>	<p>Default = Off.</p> <p>When selected, supports Provisional Reliable Acknowledgement (PRACK) on SIP trunks. Enable this parameter when you want to ensure that provisional responses, such as announcement messages, have been delivered. Provisional responses provide information on the progress of the request that is in process. For example, while a cell phone call is being connected, there may be a delay while the cell phone is located; an announcement such as “please wait while we attempt to reach the subscriber” provides provisional information to the caller while the request is in process. PRACK, which is defined in RFC 3262, provides a mechanism to ensure the delivery of these provisional responses.</p>
<b>Force direct media with phones</b>	<p>Default = On</p> <p>The setting is only available when the trunk’s <b>Re-invite Supported</b> and <b>Allow Direct Media Path</b> settings are enabled and its DTMF Support option is set to <b>RFC2833/RFC4733</b>. It also requires the H.323 IP extension involved in the call to also have <b>Allow Direct Media Path</b> enabled. This feature is only supported with Avaya H.323 IP telephones. For calls where the Avaya H.323 IP extension using the trunk is doing so as a direct media call, this feature allows digits pressed on the extension to be detected and the call changed to an indirect media call so that RFC2833 DTMF can be sent. The call remains as an indirect media call for 15 seconds after the last digit before reverting back to being a direct media call.</p>
<b>G.711 Fax ECAN</b>	<p>Default = Off</p> <p>This setting is only available on IP500 V2 systems when <b>Fax Transport Support</b> is set to <b>G.711</b> or <b>T.38 Fallback</b>. When IP Office detects a fax call, the IP Office negotiates to G.711 (if not already in G.711) and reconfigures the connection with echo cancellation (ECAN) based on the 'G.711 Fax ECAN field. This can be used to avoid an ECAN mismatch with the SIP trunk service provider. Also for fax calls, the connection’s NLP is disabled, a fixed jitter buffer is set and silence suppression is disabled.</p>

**Related links**

[SIP Line](#) on page 339

## T38 Fax

Navigation: [Line](#) | [SIP Line](#) | [T38 Fax](#)

The settings are available only on IP500 V2 since it can terminate T38 fax. On the **VoIP** settings for the line type, **Fax Transport Support** must be set to **T38** or **T38 Fallback**.

These settings are mergeable.

Field	Description
<b>Use Default Values</b>	Default = On. If selected, all the fields are set to their default values and greyed out.
<b>T38 Fax Version</b>	Default = 3. During fax relay, the two gateways will negotiate to use the highest version which they both support. The options are: <ul style="list-style-type: none"> <li>• 0</li> <li>• 1</li> <li>• 2</li> <li>• 3</li> </ul>
<b>Transport</b>	Default = UDPTL (fixed). Only <b>UDPTL</b> is supported. <b>TCP</b> and <b>RTP</b> transport are not supported. For <b>UDPTL</b> , redundancy error correction is supported. Forward Error Correction (FEC) is not supported.
<b>Redundancy</b> Redundancy sends additional fax packets in order to increase the reliability. However increased redundancy increases the bandwidth required for the fax transport.	
<b>Low Speed</b>	Default = 0 (No redundancy). Range = 0 to 5. Sets the number of redundant T38 fax packets that should be sent for low speed V.21 T.30 fax transmissions.
<b>High Speed</b>	Default = 0 (No redundancy). Range = 0 to 5. Sets the number of redundant T38 fax packets that should be sent for V.17, V.27 and V.28 fax transmissions.
<b>TCF Method</b>	Default = Trans TCF. TCF = Training Check Frame.
<b>Max Bit Rate (bps)</b>	Default = 14400. Lower rates can be selected if the current rate is not supported by the fax equipment or is found to not be reliable.
<b>EFlag Start Timer (msecs)</b>	Default = 2600.
<b>EFlag Stop Timer (msecs)</b>	Default = 2300.

*Table continues...*

Field	Description
<b>Tx Network Timeout (secs)</b>	Default = 150.
<b>Scan Line Fix-up</b>	Default = On.
<b>TFOP Enhancement</b>	Default = On.
<b>Disable T30 ECM</b>	Default = Off. When selected, disabled the T.30 Error Correction Mode used for fax transmission.
<b>Disable EFlags For First DIS</b>	Default = Off.
<b>Disable T30 MR Compression</b>	Default = Off.
<b>NSF Override</b>	Default = Off. If selected, the NSF (Non-Standard Facility) information sent by the T38 device can be overridden using the values in the fields below. <b>Country Code:</b> Default = 0. <b>Vendor Code:</b> Default = 0.

**Related links**

[SIP Line](#) on page 339

**SIP Credentials**

Navigation: [Line](#) | [SIP Line](#) | [SIP Credentials](#)

Used to enter the ITSP username and password for the SIP account with the ITSP. If you have several SIP accounts going to the same ITSP IP address or domain name, you can enter up to 30 sets of ITSP account names and passwords on this tab.

Use the **Add**, **Remove**, and **Edit** buttons to manage the set of credentials for the SIP trunk accounts. The settings for each account are listed below.

**Configuration Settings**

These settings are mergeable. Changes to these settings do not require a reboot of the system.

Field	Descriptions
<b>Index</b>	This number is assigned automatically and cannot be edited. If the <b>From</b> field on the SIP URI being used for the call is set to <b>Use Authentication Name</b> , the registration field of the SIP URI will indicate the index number of the SIP credentials to use for calls by that SIP URI.
<b>User Name</b>	This name must be unique and is used to identify the trunk. The name can include the domain if necessary.

*Table continues...*

Field	Descriptions
<b>Authentication Name</b>	Default = Blank.  This field can be blank but must be completed if a <b>Password</b> is also specified. This value is provided by the SIP ITSP. Depending on the settings on the Local URI tab associated with the SIP call, it may also be used as the user part of the SIP URI. The name can include the domain if necessary.
<b>Contact</b>	Default = Blank.  This field is used to enter a contact and can include the domain if necessary.
<b>Password</b>	Default = Blank.  This value is provided by the SIP ITSP. If a password is specified, the matching <b>Authentication Name</b> must also be set.
<b>Expiry</b>	Default = 60 minutes.  This setting defines how often registration with the SIP ITSP is required following any previous registration.
<b>Registration Required</b>	Default = On.  If selected, the fields above are used for registration when making calls. If exported or imported as part of a trunk template.

### Related links

[SIP Line](#) on page 339

## SIP Advanced

Navigation: [Line](#) | [SIP Line](#) | [SIP Advanced](#)

### Additional configuration information

For additional information regarding the **Media Connection Preservation** setting, see [Media Connection Preservation](#) on page 640.

### Configuration settings

These settings are mergable, with the exception of the **Media Connection Preservation** setting. Changing the **Media Connection Preservation** setting requires a “merge with service disruption”. When the configuration file is sent to the system, the SIP trunk is restarted and all calls on the line are dropped.

Field	Description
<b>Addressing</b>	

*Table continues...*

Field	Description
<b>Association Method</b>	<p>Default = By Source IP Address.</p> <p>This setting sets the method by which a SIP line is associated with an incoming SIP request.</p> <p>The match criteria used for each line can be varied. The search for a line match for an incoming request is done against each line in turn using each lines Association Method. The order of line matching uses the configured <b>Line Number</b> settings until a match occurs. If no match occurs the request is ignored. This method allows multiple SIP lines with the same address settings. This may be necessary for scenarios where it may be required to support multiple SIP lines to the same ITSP. For example when the same ITSP supports different call plans on separate lines or where all outgoing SIP lines are routed from the system via an additional on-site system. The options are:</p> <ul style="list-style-type: none"> <li>• <b>By Source IP Address:</b> This option uses the source IP address and port of the incoming request for association. The match is against the configured remote end of the SIP line, using either an IP address/port or the resolution of a fully qualified domain name.</li> <li>• <b>"From" header hostpart against ITSP domain:</b> This option uses the host part of the From header in the incoming SIP request for association. The match is against the <b>ITSP Domain Name</b> above.</li> <li>• <b>R-URI hostpart against ITSP domain:</b> This option uses the host part of the Request-URI header in the incoming SIP request for association. The match is against the <b>ITSP Domain Name</b> above.</li> <li>• <b>"To" header hostpart against ITSP domain:</b> This option uses the host part of the To header in the incoming SIP request for association. The match is against the <b>ITSP Domain Name</b> above.</li> <li>• <b>"From" header hostpart against DNS-resolved ITSP domain:</b> This option uses the host part of the FROM header in the incoming SIP request for association. The match is found by comparing the FROM header against a list of IP addresses resulting from resolution of the <b>ITSP Domain Name</b> above or, if set, the <b>Line   SIP Line   Transport   ITSP Proxy Address</b> setting.</li> <li>• <b>"Via" header hostpart against DNS-resolved ITSP domain:</b> This option uses the host part of the VIA header in the incoming SIP request for association. The match is found by comparing the VIA header against a list of IP addresses resulting from resolution of the <b>ITSP Domain Name</b> above or, if set, the <b>Line   SIP Line   Transport   ITSP Proxy Address</b> setting.</li> <li>• <b>"From" header hostpart against ITSP proxy:</b> This option uses the host part of the "From" header in the incoming SIP request for association. The match is against the <b>Line   SIP Line   Transport   ITSP Proxy Address</b> setting.</li> <li>• <b>"To" header hostpart against ITSP proxy:</b> This option uses the host part of the From header in the incoming SIP request for association. The match is against the <b>Line   SIP Line   Transport   ITSP Proxy Address</b> setting.</li> </ul>

*Table continues...*



Field	Description
	<ul style="list-style-type: none"> <li>• <b>R-URI hostpart against ITSP proxy:</b> This option uses the host part of the Request-URI in the incoming SIP request for association. The match is against the <b>Line   SIP Line   Transport   ITSP Proxy Address</b> setting.</li> </ul>
<b>Call Routing Method</b>	<p>Default = Request URI.</p> <p>This field allows selection of which incoming SIP information should be used for incoming number matching by the system's incoming call routes. The options are to match either the <b>Request URI</b> or the <b>To Header</b> element provided with the incoming call.</p>
<b>Use P-Called-Party</b>	<p>Default = Off.</p> <p>When enabled, IP Office reads the <code>P-Called-Party ID</code> header if present in the SIP message and routes the incoming SIP calls based on it. The feature can be enabled on public SIP trunk interfaces. The configuration should be present in SIP Trunks templates. If not present, will be treated as disabled. If the feature is enabled and the header is not present in the SIP message, IP Office uses the header configured in the Call Routing method for Incoming Call Route.</p>
<b>Suppress DNS SRV Lookups</b>	<p>Default = Off.</p> <p>Controls whether to send SRV queries for this endpoint, or just NAPTR and A record queries.</p>
<b>Identity</b>	
<b>Use Phone Context</b>	<p>Default = Off.</p> <p>When set to On, signals SIP enabled PBXs that the call routing identifier is a telephone number.</p>
<b>Add user=phone</b>	<p>Default = Off.</p> <p>This setting is available when <b>Use Phone Context</b> is set to On.</p> <p>This setting adds the SIP parameter <b>user</b> with value <b>phone</b> to the From and To SIP headers in outgoing calls.</p>
<b>Use + for International</b>	<p>Default = Off.</p> <p>When set to On, outgoing international calls use E.164/International format with a '+' followed by the country code and then the directory number.</p>
<b>Use PAI for Privacy</b>	<p>Default = Off.</p> <p>When set to On, if the caller ID is withheld, the SIP message From: header is made anonymous, and the caller's identity, for admission control, billing, and emergency services, is inserted into the P-Asserted-Identity header. This mechanism should only be used in a trusted network and must be stripped out of the SIP message before it is forwarded outside the trusted domain.</p>
<b>Use Domain for PAI</b>	<p>Default = Off.</p> <p>When set to Off, the DNS resolved IP address of the ITSP Proxy is used for the host part in the P-Asserted-Identity header. When set to On, the the Domain for PAI is used.</p>

*Table continues...*

Field	Description
<b>Caller ID FROM Header</b>	Default = Off. Incoming calls can include caller ID information in both the From field and in the PAI fields. When this option is selected, the caller ID information in the From field is used rather than that in the PAI fields.
<b>Send From In Clear</b>	Default = Off. When selected, the user ID of the caller is included in the From field. This applies even if the caller has selected to be or is configured to be anonymous, though their anonymous state is honored in other fields used to display the caller identity.
<b>Cache Auth Credentials</b>	Default = On. When set to On, allows the credentials challenge and response from a registration transaction to be automatically inserted into later SIP messages without waiting for a subsequent challenge.
<b>Add UUI header</b>	Default — Off. When set to On, the User-to-User Information (UUI) is passed in SIP headers to applications.
<b>Add UUI header to redirected calls</b>	Default — Off. When set to On, the UUI is passed in SIP headers for calls that are redirected, for example, forwarded calls, twinned calls. This field can be modified only if the <b>Add UUI header</b> is set to On.
<b>User-Agent and Server Headers</b>	Default = Blank (Use system type and software level). The value set in this field is used as the User-Agent and Server value included in SIP request headers made by this line. If the field is blank, the type of IP Office system and its software level used. Setting a unique value can be useful in call diagnostics when the system has multiple SIP trunks.
<b>Send Location Info</b>	Default = Never. The options are: <ul style="list-style-type: none"> <li>• <b>Never</b>: Do not send location information.</li> <li>• <b>Emergency Calls</b>: When set to <b>Emergency Calls</b>, the location defined at <b>Location   Address</b> is sent as part of the INVITE message when emergency calls are made.</li> </ul>
<b>Media</b>	
<b>Allow Empty INVITE</b>	Default = Off. When set to On, allows 3pcc devices to initiate calls to IP Office by sending an INVITE without SDP.
<b>Send Empty re-INVITE</b>	Default = Off. This option is only available if <b>Line   SIP Line   VoIP   Re-Invite Supported</b> is selected. If set to On, when connecting a call between two endpoints, IP Office sends an INVITE without SDP in order to solicit the full media capabilities of both parties.

*Table continues...*

Field	Description
<b>Allow To Tag Change</b>	Default = Off. When set to On, allows the IP Office to change media parameters when connecting a call to a different party than that which was advertised in the media parameters of provisional responses, such as 183 Session Progress.
<b>P-Early-Media Support</b>	Default = None. The options are: <ul style="list-style-type: none"> <li>• <b>None:</b> IP Office will not advertise support of this SIP header and will always take incoming early media into account regardless of presence of this header</li> <li>• <b>Receive:</b> IP Office will advertise support of this SIP header and will discard incoming early media unless this header is present in the sip message.</li> <li>• <b>All:</b> IP Office will advertise support of this sip header, will discard incoming early media unless this header is present in the sip message and will include this sip header when providing early media.</li> </ul>
<b>Send SilenceSupp=off</b>	Default = Off. Used for the G711 codec. When checked, the silence suppression off attribute is sent in SDP on this trunk.
<b>Force Early Direct Media</b>	Default = Off. When set to On, allows the direct connection of early media streams to IP endpoints rather than anchoring it at the IP Office.
<b>Media Connection Preservation</b>	Default = Disabled. When enabled, allows established calls to continue despite brief network failures. Call handling features are no longer available when a call is in a preserved state. Preservation on public SIP trunks is not supported until tested with a specific service provider.
<b>Indicate HOLD</b>	Default = Off. When enabled, the system sends a HOLD INVITE to the SIP trunk endpoint.
<b>Call Control</b>	
<b>Call Initiation Timeout (s)</b>	Default = 4 seconds. Range = 1 to 99 seconds. Sets how long the system should wait for a response to its attempt to initiate a call before following the alternate routes set in an ARS form.
<b>Call Queuing Timeout (m)</b>	Default = 5 minutes. For incoming calls, how many minutes to wait before dropping a call that has been queued waiting for a free VCM resource, or has remained in the unanswered state. For outgoing calls, how many minutes to wait for the call to be answered after receiving a provisional response.

*Table continues...*

Field	Description
<b>Service Busy Response</b>	<p>Default = 486 - Busy Here (503 - Service Unavailable for the France2 locale).</p> <p>For calls that result in a busy response from IP Office, this setting determines the response code. The options are:</p> <ul style="list-style-type: none"> <li>• <b>486 - Busy Here</b></li> <li>• <b>503 - Service Unavailable</b></li> </ul>
<b>on No User Responding Send</b>	<p>Default = 408-Request Timeout.</p> <p>Specifies the cause to be used when releasing incoming calls from SIP trunks, when the cause of releasing is that user did not respond. The options are 408-Request Timeout or 480 Temporarily Unavailable.</p>
<b>Action on CAC Location Limit</b>	<p>Default = Allow Voicemail</p> <p>When set to <b>Allow Voicemail</b>, the call is allowed to go to a user's voicemail when the user's location call limit has been reached. When set to <b>Reject Call</b>, the call is rejected with the failure response code configured in the <b>Service Busy Response</b> field.</p>
<b>Suppress Q.850 Reason Header</b>	<p>Default = Off.</p> <p>When SIP calls are released by sending BYE and CANCEL, a release reason header is added to the message. When set to On, the Q.850 reason header is not included.</p>
<b>Emulate NOTIFY for REFER</b>	<p>Default = Off.</p> <p>Use for SIP providers that do not send NOTIFY messages. When set to On, after IP Office issues a REFER, and the provider responds with 202 ACCEPTED, IP Office will assume the transfer is complete and issue a BYE.</p>
<b>No REFER if using Diversion</b>	<p>Default = Off.</p> <p>When enabled, REFER is not sent on the trunk if the forwarding was done with 'Send Caller ID = Diversion Header'. Applies to Forwards and Twinning.</p>

**Related links**

[SIP Line](#) on page 339

**Engineering**

Navigation: [Line](#) | [SIP Line](#) | [Engineering](#)

This page is used to enter values that apply special features to the SIP line. These are entered using the **Add**, **Edit** and **Remove** buttons.

These settings are mergeable. Changes to these settings do not require a reboot of the system.

**Related links**

[SIP Line](#) on page 339

## SIP DECT Line

A SIP DECT line can be manually added. SIP DECT lines are used to manage D100 Base Station operation.

### Related links

[Line](#) on page 279

[SIP DECT Base](#) on page 373

[VoIP](#) on page 374

## SIP DECT Base

Navigation: [Line](#) | [SIP DECT Line](#) | [SIP DECT Base](#)

Currently, IP Office supports four D100 Base Stations.

These settings are not mergeable. Changes to these settings requires a reboot of the system.

Field	Description
<b>Line Number</b>	Default = Blank. A unique line number associated with the SIP DECT Base Station. <b>Associated Extensions</b> are other extensions that can log into the base station.
<b>Base Name</b>	Default = Blank. Maximum 16 characters.  A name assigned to the base station. Each base station provisioned on the IP Office must have a unique name. The field cannot be blank. The format is an alphanumeric string with no special characters.
<b>Base MAC Address</b>	Default = Blank.  The MAC Address of the base station. If only one base station is provisioned, the field can remain at the default value. If multiple base stations are provisioned, the MAC address for each base station must be entered.
<b>Configure Base IP</b>	
<b>Configure Base IP</b>	Default = Off.  Set to <b>On</b> to configure IP address attributes for the base station. When enabled, the Configure Base IP settings are displayed.
<b>DHCP Client</b>	Default = On.  When enabled, specifies that the base station operates as a DHCP client. When enabled, not other IP address attributes can be configured.
<b>IP Address</b>	Default = Blank.  The IP address of the base station. The IP address must be on the same subnet as one of the LAN interfaces.
<b>IP Mask</b>	Default = Blank.  IP address mask.

*Table continues...*

Field	Description
<b>IP Gateway</b>	Default = Blank. The default gateway address
<b>Provisioning Server</b>	Default = IP Office interface address. The server address from where the Base Station configuration files can be retrieved.
<b>Description</b>	Default = Blank. Maximum 31 characters. Use this field to enter a description of this configuration.

**Related links**

[SIP DECT Line](#) on page 373

**VoIP**

Navigation: **Line | SIP DECT Line | VoIP**

This form is used to configure the VoIP setting applied to calls on the SIP DECT line.

These settings are not mergeable. Changes to these settings requires a reboot of the system.

Field	Description
<b>IP Address</b>	Default = Blank. The IP address of the SIP DECT extension.
<b>Codec Selection</b>	Default = Custom This field defines the codec or codecs offered during call setup. The codecs available to be used are set through <b>System   VoIP</b> . The Custom option allows specific configuration of the codec preferences to be different from the system <b>Default Selection</b> list. When <b>Custom</b> is selected, the list can be used to select which codecs are in the <b>Unused</b> list and in the <b>Selected</b> list and to change the order of the selected codecs. The D100 Base Station supports only G711 codecs.
<b>TDM   IP Gain</b>	Default = Default (0dB). Range = -31dB to +31dB. Allows adjustment of the gain on audio from the system TDM interface to the IP connection. This field is not shown on Linux based platforms.
<b>IP   TDM Gain</b>	Default = Default (0dB). Range = -31dB to +31dB. Allows adjustment of the gain on audio from the IP connection to the system TDM interface. This field is not shown on Linux based platforms.
<b>DTMF Support</b>	Default =RFC2833 The D100 Base Station supports only RFC2833.

*Table continues...*

Field	Description
<b>VoIP Silence Suppression</b>	Default = Off  When selected, this option will detect periods of silence on any call over the line and will not send any data during those silent periods. This feature is not used on IP lines using <b>G.711</b> between systems. On trunk's between networked systems, the same setting should be set at both ends.
<b>Local Hold Music</b>	Default = Off
<b>Allow Direct Media Path</b>	Default = On  This settings controls whether IP calls must be routed via the system or can be routed alternately if possible within the network structure. <ul style="list-style-type: none"> <li>• If enabled, IP calls can take routes other than through the system. This removes the need for a voice compression channel. Both ends of the calls must support Direct Media and be using the same protocol (H.323 or SIP). Enabling this option may cause some vendors problems with changing the media path mid call.</li> <li>• If disabled or not supported at on one end of the call, the call is routed via the system. RTP relay support allows calls between devices using the same audio codec to not require a voice compression channel.</li> </ul>
<b>RE-Invite Supported</b>	Default = Off.  When enabled, Re-Invite can be used during a session to change the characteristics of the session. For example when the target of an incoming call or a transfer does not support the codec originally negotiated on the trunk. Requires the ITSP to also support <b>Re-Invite</b> .

#### Related links

[SIP DECT Line](#) on page 373

## SM Line

This type of line is used to create a SIP connection between an IP Office and an Avaya Aura® Session Manager. The other end of the SIP connection must be configured on the Session Manager as a SIP Entity Link.

An SM Line can only be added to IP Office system Standard Mode or Server Edition configurations. It is typically used in IP Office Standard mode in Enterprise Branch deployments connected to the Avaya Aura® network. For more details about IP Office Enterprise Branch deployments refer to *Deploying Avaya IP Office™ Platform as an Enterprise Branch with Avaya Aura® Session Manager*.

An SM Line can also be used in IP Office Server Edition to connect to an Avaya Aura® Session Manager. Through the SM Line, IP Office Server Edition supports interoperability with Avaya Aura® Session Manager. It also supports interoperability, via the Avaya Aura® Session Manager, with Avaya Aura® Communication Manager systems and with CS 1000 systems. Note that IP Office Server Edition is not used as an enterprise branch product and does not support some of the IP Office enterprise branch functionality, such as management by Avaya Aura® System Manager, WebLM licensing, Centralized Users or voicemail over the SM Line.

If the Avaya Aura® network has multiple Avaya Aura® Session Managers to provide redundancy, two SM lines can be added, one configured for each Avaya Aura® Session Manager.

**Related links**

[Line](#) on page 279

[Session Manager](#) on page 376

[VoIP](#) on page 378

[T38 Fax](#) on page 383

**Session Manager**

Navigation: [Line](#) | [SM Line](#) | [Session Manager](#)

**Additional configuration information**

For additional information regarding the **Media Connection Preservation** setting, see [Media Connection Preservation](#) on page 640.

**Configuration settings**

These settings are not mergeable. Changes to these settings require a reboot of the system.

Changing the **In Service** setting to **Disabled** (out of service) requires a system reboot. However, changing the **In Service** setting to **Enabled** is mergeable. Configuration changes made while the line is out of service are also mergeable.

Field	Description
<p><b>Line Number</b></p>	<p>Default = Auto-filled. Range = 1 to 249 (IP500 V2)/349 (Server Edition).</p> <p>Enter the line number that you wish. Note that this must be unique. On IP500 V2 systems, line numbers 1 to 16 are reserved for internal hardware.</p> <ul style="list-style-type: none"> <li> <p><b>Session Manager line prioritization:</b> Up to two Session Manager lines can be configured. The two Session Manager lines are prioritized based on the line number. The lower line number is considered the primary Session Manager line. For example, if the first Session Manager line is configured as line number 17 and the second Session Manager line is configured as line 18, then line number 17 is considered the primary Session Manager line. If you want to designate the second Session Manager line (line 18 in this example) as the primary Session Manager line, you must change one or both of the line numbers so that the second Session Manager line is configured with a lower number than the current primary line.</p> </li> <li> <p><b>Session Manager line redundancy:</b> Based on the priority of the Session Manager lines designated by the line number, the active line to which the IP Office sends all calls will always be the highest priority Session Manager line in service. That is, if the primary Session Manager line is in service, it will be the active line for sending calls. If the connection to the primary Session Manager line is lost, causing the IP Office to switch to the secondary Session Manager line, then when the primary line comes back up later, the IP Office reverts back to the primary Session Manager line.</p> </li> </ul>

*Table continues...*



Field	Description
<b>In Service</b>	<p>Default = Enabled</p> <p>This option can be used to administratively disable the SM Line. It does not reflect the dynamic state of the line. If an SM Line is administratively disabled it is not equivalent to being in the dynamic out of service state.</p>
<b>SM Domain Name</b>	<p>This should match a SIP domain defined in the Session Manager system's SIP Domains table. Unless there are reasons to do otherwise, all the Enterprise Branch systems in the Avaya Aura<sup>®</sup> network can share the same domain.</p>
<b>SM Address</b>	<p>Enter the IP address of the Session Manager the line should use in the Avaya Aura network. The same Session Manager should be used for the matching <b>Entity Link</b> record in the Avaya Aura<sup>®</sup> configuration.</p>
<b>Outgoing Group ID</b>	<p>Default = 98888</p> <p>This value is not changeable. However note the value as it is used in Enterprise Branch short codes used to route calls to the Session Manager.</p>
<b>Prefix</b>	<p>Default = Blank</p> <p>This prefix will be added to any source number received with incoming calls.</p>
<b>Max Calls</b>	<p>Default = 10</p> <p>Sets the number of simultaneous calls allowed between the Enterprise Branch and Session Manager using this connection. Each call will use one of the available licenses that are shared by all SIP trunks configured in the system.</p>
<b>Network Type</b>	<p>Default = Public.</p> <p>This option is available if <b>System   Telephony   Telephony   Restrict Network Interconnect</b> is enabled. It allows the trunk to be set as either <b>Public</b> or <b>Private</b>. The system will return number busy indication to any attempt to connect a call on a <b>Private</b> trunk to a <b>Public</b> trunk or vice versa. This restriction includes transfers, forwarding and conference calls.</p> <p>Due to the nature of this feature, its use is not recommended on systems also using any of the following other system features: multi-site networks, VPNremote, application telecommuter mode.</p>
<b>Include location specific information</b>	<p>Default = Off.</p> <p>Enabled when <b>Network Type</b> is set to <b>Private</b>. Set to <b>On</b> if the PBX on the other end of the trunk is toll compliant.</p>
<b>URI Type</b>	<p>Default = SIP.</p> <p>When <b>SIP</b> or <b>SIPS</b> is selected in the drop-down box, the SIP URI format is used (for example, name@example.com). This affects the <b>From</b> field of outgoing calls. The <b>To</b> field for outgoing calls will always use the format specified by the short codes used for outgoing call routing. Recommendation: When SIP Secured URI is required, the URI Type should be set to <b>SIPS</b>. <b>SIPS</b> can be used only when Layer 4 Protocol is set to TLS.</p>

*Table continues...*

Field	Description
<b>Media Connection Preservation</b>	<p>Default = Enabled.</p> <p>When enabled, attempts to maintain established calls despite brief network failures. Call handling features are no longer available when a call is in a preserved state. When enabled, Media Connection Preservation applies to Avaya H.323 phones that support connection preservation.</p>
<b>Location</b>	<p>Default = Cloud.</p> <p>Specify a location to associate the extension with a physical location. Associating an extension with a location:</p> <ul style="list-style-type: none"> <li>• Allows emergency services to identify the source of an emergency call.</li> <li>• Allows you to configure call admission control settings for the location.</li> </ul> <p>The drop down list contains all locations that have been defined in the <b>Location</b> form.</p>
<b>Network Configuration</b>	
<p>TLS connections support the following ciphers:</p> <ul style="list-style-type: none"> <li>• TLS_RSA_WITH_AES_128_CBC_SHA</li> <li>• TLS_RSA_WITH_AES_256_CBC_SHA</li> <li>• TLS_DHE_RSA_WITH_AES_128_CBC_SHA</li> <li>• TLS_DHE_RSA_WITH_AES_256_CBC_SHA</li> </ul>	
<b>Layer 4 Protocol</b>	Default = TCP.
<b>Send Port</b>	When Network Configuration is set to TLS, the default setting is 5061. When Network Configuration is set to TCP, the default setting is 5060.
<b>Listen Port</b>	When Network Configuration is set to TLS, the default setting is 5061. When Network Configuration is set to TCP, the default setting is 5060.
<b>Session Timer</b>	<p>Default = 1200. Range = 90 to 64800</p> <p>This field specifies the session expiry time. At the half way point of the expiry time, a session refresh message is sent. Setting the field to <b>On Demand</b> disables the session timer.</p> <p>Communication Manager supports SIP session refresh via UPDATE in Communication Manger release 6.2 SP1 and later. If using an earlier release of Communication Manager, then the <b>Session Timer</b> parameter must be set to <b>On Demand</b>.</p>
<b>Description</b>	<p>Default = Blank. Maximum 31 characters.</p> <p>Use this field to enter a description of this configuration.</p>

**Related links**

[SM Line](#) on page 375

**VoIP**

Navigation: [Line](#) | [SM Line](#) | [VoIP](#)

These settings are mergeable. Changes to these settings do not require a reboot of the system.

These settings can be edited online. Changes to these settings do not require a reboot of the system.

Field	Description
<b>Codec Selection</b>	<p>Default = System Default</p> <p>This field defines the codec or codecs offered during call setup. The available codecs in default preference order are:</p> <ul style="list-style-type: none"> <li>• <b>G.711 A-Law</b></li> <li>• <b>G.711 U-LAW</b></li> <li>• <b>G.729</b></li> <li>• <b>G.723.1</b></li> </ul> <p>Note that the default order for G.711 codecs varies to match the system's default companding setting. <b>G.723.1</b> is not supported on Linux based systems.</p> <p>The <b>G.722 64K</b> codec is also supported on IP500 V2 systems with IP500 VCM, IP500 VCM V2 or IP500 Combo cards. For Server Edition, it is supported on Primary Server, Secondary Server and Expansion System (L) systems and on Expansion System (V2) systems fitted with IP500 VCM, IP500 VCM V2 or IP500 Combo.</p> <p>The codecs available in this form are set through the codec list on <b>System   VoIP</b>.</p> <p>Within a network of systems, it is strongly recommended that all the systems and the lines connecting those systems use the same codecs.</p> <p>The options are:</p> <ul style="list-style-type: none"> <li>• <b>System Default</b> This is the default setting. When selected, the codec list below matches the codecs set in the system wide list.</li> <li>• <b>Custom</b> This option allows specific configuration of the codec preferences to be different from the system list. When <b>Custom</b> is selected, the list can be used to select which codecs are in the <b>Unused</b> list and in the <b>Selected</b> list and to change the order of the selected codecs.</li> </ul>

*Table continues...*

Field	Description
<b>Fax Transport Support</b>	<p>Default = None.</p> <p>This option is only available if <b>Re-Invite Supported</b> is selected. When enabled, the system performs fax tone detection on calls routed via the line and, if fax tone is detected, renegotiates the call codec as configured below. The SIP line provider must support the selected fax method and Re-Invite. The system must have available VCM resources using an IP500 VCM, IP500 VCM V2 or IP500 Combo base card.</p> <p>For systems in a network, fax relay is supported for fax calls between the systems.</p> <p>The options are:</p> <ul style="list-style-type: none"> <li>• <b>None</b> Select this option if fax is not supported by the line provider.</li> <li>• <b>G.711</b> G.711 is used for the sending and receiving of faxes.</li> <li>• <b>T38</b> T38 is used for the sending and receiving of faxes. This option is not supported by Linux based systems.</li> <li>• <b>T38 Fallback</b> When you enable this option, T38 is used for sending and receiving faxes on a SIP line. If the called destination does not support T38, the system will send a re-invite to change the transport method to G.711. This option is not supported on Linux based systems.</li> </ul>
<b>Call Initiation Timeout</b>	<p>Default = 4 seconds. Range = 1 to 99 seconds.</p> <p>This option sets how long the system should wait for a response to its attempt to initiate a call before following the alternate routes set in an ARS form.</p>
<b>DTMF Support</b>	<p>Default = RFC2833.</p> <p>This setting is used to select the method by which DTMF key presses are signalled to the remote end. The options are:</p> <ul style="list-style-type: none"> <li>• <b>In Band</b></li> <li>• <b>RFC2833</b></li> <li>• <b>Info</b></li> </ul>

*Table continues...*

Field	Description
<b>Media Security</b>	<p>Default = Same as System.</p> <p>These setting control whether SRTP is used for this line and the settings used for the SRTP. The options are:</p> <ul style="list-style-type: none"> <li>• <b>Same as System:</b> Matches the system setting at <b>System   VoIP Security</b>.</li> <li>• <b>Disabled:</b> Media security is not required. All media sessions (audio, video, and data) will be enforced to use RTP only.</li> <li>• <b>Preferred:</b> Media security is preferred. Attempt to use secure media first and if unsuccessful, fall back to non-secure media.</li> <li>• <b>Enforced:</b> Media security is required. All media sessions (audio, video, and data) will be enforced to use SRTP only.</li> </ul> <p> <b>Warning:</b></p> <p>Selecting <b>Enforced</b> on a line or extension that does not support media security will result in media setup failures.</p>
<b>Advanced Media Security Options</b>	<p>Not displayed if <b>Media Security</b> is set to <b>Disabled</b>. The options are:</p> <ul style="list-style-type: none"> <li>• <b>Same as System:</b> Use the same settings as the system setting configured on <b>System   VoIP Security</b>.</li> <li>• <b>Encryptions:</b> Default = RTP This setting allows selection of which parts of a media session should be protected using encryption. The default is to encrypt just the RTP stream (the speech).</li> <li>• <b>Authentication:</b> Default = RTP and RTCP This setting allows selection of which parts of the media session should be protected using authentication.</li> <li>• <b>Replay Protection SRTP Window Size:</b> Default = 64. Currently not adjustable.</li> <li>• <b>Crypto Suites:</b> Default = SRTP_AES_CM_128_SHA1_80. There is also the option to select SRTP_AES_CM_128_SHA1_32.</li> </ul>
<b>VoIP Silence Suppression</b>	<p>Default = Off.</p> <p>When selected, this option will detect periods of silence on any call over the line and will not send any data during those silent periods. This feature is not used on IP lines using <b>G.711</b> between systems. On trunk's between networked systems, the same setting should be set at both ends.</p>

*Table continues...*

Field	Description
<b>Allow Direct Media Path</b>	<p>Default = On</p> <p>This settings controls whether IP calls must be routed via the system or can be routed alternatively if possible within the network structure.</p> <ul style="list-style-type: none"> <li>• If enabled, IP calls can take routes other than through the system, removing the need for system resources such as voice compression channels. Both ends of the calls must support Direct Media and have compatible VoIP settings such as matching codec, etc. If otherwise, the call will remain routed via the system. Enabling this option may cause some vendors problems with changing the media path mid call.</li> <li>• If disabled, the call is routed via the system. In that case, RTP relay support may still allow calls between devices using the same audio codec to not require a voice compression channel.</li> </ul>
<b>Re-Invite Supported</b>	<p>Default = On.</p> <p>When enabled, Re-Invite can be used during a session to change the characteristics of the session. For example when the target of an incoming call or a transfer does not support the codec originally negotiated on the trunk. Requires the ITSP to also support <b>Re-Invite</b>.</p>
<b>Codec Lockdown</b>	<p>Default = Off.</p> <p>Supports RFC 3264 Section 10.2 when <b>RE-Invite Supported</b> is enabled. In response to a SIP offer with a list of codecs supported, some SIP user agents supply a SDP answer that also lists multiple codecs. This means that the user agent may switch to any of those codecs during the session without further negotiation. The system does not support multiple concurrent codecs for a session, so loss of speech path will occur if the codec is changed during the session. If codec lockdown is enabled, when the system receives an SDP answer with more than one codec from the list of offered codecs, it sends an extra re-INVITE using just a single codec from the list and resubmits a new SDP offer with just the single chosen codec.</p>
<b>Force direct media with phones</b>	<p>Default = On</p> <p>The setting is only available when the trunk's <b>Re-invite Supported</b> and <b>Allow Direct Media Path</b> settings are enabled and its DTMF Support option is set to <b>RFC2833/RFC4733</b>. It also requires the H.323 IP extension involved in the call to also have <b>Allow Direct Media Path</b> enabled. This feature is only supported with Avaya H.323 IP telephones. For calls where the Avaya H.323 IP extension using the trunk is doing so as a direct media call, this feature allows digits pressed on the extension to be detected and the call changed to an indirect media call so that RFC2833 DTMF can be sent. The call remains as an indirect media call for 15 seconds after the last digit before reverting back to being a direct media call.</p>

*Table continues...*

Field	Description
<b>G.711 Fax ECAN</b>	<p>Default = Off</p> <p>This setting is only available on IP500 V2 systems when <b>Fax Transport Support</b> is set to <b>G.711</b> or <b>T.38 Fallback</b>. When IP Office detects a fax call, the IP Office negotiates to G.711 (if not already in G.711) and reconfigures the connection with echo cancellation (ECAN) based on the 'G.711 Fax ECAN field. This can be used to avoid an ECAN mismatch with the SIP trunk service provider. Also for fax calls, the connection's NLP is disabled, a fixed jitter buffer is set and silence suppression is disabled.</p>

### Related links

[SM Line](#) on page 375

## T38 Fax

Navigation: [Line](#) | [SM Line](#) | [T38 Fax](#)

The settings are available only on IP500 V2 since it can terminate T38 fax. On the **VoIP** settings for the line type, **Fax Transport Support** must be set to **T38** or **T38 Fallback**.

These settings are mergeable.

Field	Description
<b>Use Default Values</b>	<p>Default = On.</p> <p>If selected, all the fields are set to their default values and greyed out.</p>
<b>T38 Fax Version</b>	<p>Default = 3.</p> <p>During fax relay, the two gateways will negotiate to use the highest version which they both support. The options are:</p> <ul style="list-style-type: none"> <li>• 0</li> <li>• 1</li> <li>• 2</li> <li>• 3</li> </ul>
<b>Transport</b>	<p>Default = UDPTL (fixed).</p> <p>Only <b>UDPTL</b> is supported. <b>TCP</b> and <b>RTP</b> transport are not supported. For <b>UDPTL</b>, redundancy error correction is supported. Forward Error Correction (FEC) is not supported.</p>
<b>Redundancy</b>	
<p>Redundancy sends additional fax packets in order to increase the reliability. However increased redundancy increases the bandwidth required for the fax transport.</p>	
<b>Low Speed</b>	<p>Default = 0 (No redundancy). Range = 0 to 5.</p> <p>Sets the number of redundant T38 fax packets that should be sent for low speed V.21 T.30 fax transmissions.</p>

*Table continues...*

Field	Description
<b>High Speed</b>	Default = 0 (No redundancy). Range = 0 to 5. Sets the number of redundant T38 fax packets that should be sent for V.17, V.27 and V.28 fax transmissions.
<b>TCF Method</b>	Default = Trans TCF. TCF = Training Check Frame.
<b>Max Bit Rate (bps)</b>	Default = 14400. Lower rates can be selected if the current rate is not supported by the fax equipment or is found to not be reliable.
<b>EFlag Start Timer (msecs)</b>	Default = 2600.
<b>EFlag Stop Timer (msecs)</b>	Default = 2300.
<b>Tx Network Timeout (secs)</b>	Default = 150.
<b>Scan Line Fix-up</b>	Default = On.
<b>TFOP Enhancement</b>	Default = On.
<b>Disable T30 ECM</b>	Default = Off. When selected, disabled the T.30 Error Correction Mode used for fax transmission.
<b>Disable EFlags For First DIS</b>	Default = Off.
<b>Disable T30 MR Compression</b>	Default = Off.
<b>NSF Override</b>	Default = Off. If selected, the NSF (Non-Standard Facility) information sent by the T38 device can be overridden using the values in the fields below. <b>Country Code:</b> Default = 0. <b>Vendor Code:</b> Default = 0.

**Related links**

[SM Line](#) on page 375

---

## IP Office Line

This line type is used to connect two IP Office systems.

In previous releases, connecting two IP Office systems was achieved using H.323 Lines configured with **Supplementary Services** set to **IP Office SCN**. In the current release, the IP Office line type is used to connect IP Office systems. Separating out the IP Office line type from



the H.323 line type allows for the logical grouping of features and functions available when connecting two IP Office systems, including IP Office systems connected through the cloud.

**\* Note:**

Setting an IP Office line with **Transport Type = Proprietary** and **Networking Level = SCN** will interwork with a previous release system configured with an H.323 SCN line.

**Related links**

[Line](#) on page 279

[Line](#) on page 385

[Short Codes](#) on page 390

[VoIP Settings](#) on page 390

[T38 Fax](#) on page 393

**Line**

Navigation: [Line](#) | [IP Office Line](#) | [Line](#)

**Additional configuration information**

For information on the **SCN Resiliency Options**, see [Server Edition Resiliency](#) on page 746.

**Configuration Settings**

These settings are mergeable. Changes to these settings do not require a reboot of the system.

Field	Description
<b>Line Number</b>	Default = Auto-filled. Range = 1 to 249 ( <i>IP500 V2</i> )/349 ( <i>Server Edition</i> ). Enter the line number that you wish. Note that this must be unique. On IP500 V2 systems, line numbers 1 to 16 are reserved for internal hardware.
<b>Transport Type</b>	Default = Proprietary. The options are <ul style="list-style-type: none"> <li>• <b>Proprietary</b>: The default connection type when connecting two IP Office systems.</li> <li>• <b>WebSocket Client / WebSocket Server</b>: A WebSocket connection is an HTTP / HTTPS initiated TCP pipe through which Call signalling and Network Signaling is tunneled. This transport type is used to connect IP Office systems through the cloud. Selecting one of the WebSocket options enables the <b>Security</b> field and the <b>Password</b> fields.</li> </ul>
<b>Networking Level</b>	Default = SCN. The options are <ul style="list-style-type: none"> <li>• <b>None</b>: No supplementary services are supported.</li> <li>• <b>SCN</b>: This option is used to link IP Office system within a multi-site network. The systems within a multi-site network automatically exchange information about users and extensions, allowing remote users to be called without any additional configuration on the local system.</li> </ul>

*Table continues...*

Field	Description
<b>Security</b>	<p>Default = Unsecured.</p> <p>The Security field is available when <b>Transport Type</b> is set to <b>WebSocket Client</b> or <b>WebSocket Server</b>.</p> <p>The options are</p> <ul style="list-style-type: none"> <li>• <b>Unsecured</b> : The connection uses HTTP/TCP.</li> <li>• <b>Medium</b>: The connection uses HTTPS/TLS.</li> <li>• <b>High</b>: The connection uses HTTPS/TLS. The server certificate store must contain the client identity certificate.</li> </ul>
<b>Network Type</b>	<p>Default = Public.</p> <p>This option is available if <b>System   Telephony   Telephony   Restrict Network Interconnect</b> is enabled. It allows the trunk to be set as either <b>Public</b> or <b>Private</b>. The system will return number busy indication to any attempt to connect a call on a <b>Private</b> trunk to a <b>Public</b> trunk or vice versa. This restriction includes transfers, forwarding and conference calls.</p> <p>Due to the nature of this feature, its use is not recommended on systems also using any of the following other system features: multi-site networks, VPNremote, application telecommuter mode.</p>
<b>Include location specific information</b>	<p>Default = Off.</p> <p>Enabled when <b>Network Type</b> is set to <b>Private</b>. Set to <b>On</b> if the PBX on the other end of the trunk is toll compliant.</p>
<b>Telephone Number</b>	<p>Default = Blank.</p> <p>Used to remember the telephone number of this line. For information only.</p>
<b>Prefix</b>	<p>Default = Blank.</p> <p>The prefix is used in the following ways:</p> <ul style="list-style-type: none"> <li>• <b>For incoming calls</b> The ISDN messaging tags indicates the call type (National, International or Unknown). If the call type is unknown, then the number in the Prefix field is added to the ICLID.</li> <li>• <b>For outgoing calls</b> The prefix is not stripped, therefore any prefixes not suitable for external line presentation should be stripped using short codes.</li> </ul>

*Table continues...*

Field	Description
<b>Outgoing Group ID</b>	<p>Default = 1. Range 0 to 99999.</p> <p>Short codes that specify a number to dial can specify the line group to be used. The system will then seize a line from those available with a matching Outgoing Group ID.</p> <p>In a Server Edition/Select network, the <b>Outgoing Group ID</b> used for lines to a system must be unique within the network. The same ID cannot be used in the configuration of any lines to another server system in the network.</p> <p><b>Reserved Group ID Numbers:</b></p> <ul style="list-style-type: none"> <li>• <b>90000 - 99999</b> Reserved for system use (not enforced).</li> <li>• <b>99999 and 99998</b> In a Server Edition/Select network, reserved for the IP Office lines to the primary and secondary server respectively.</li> <li>• <b>99001 to 99148</b> In a Server Edition/Select network, reserved for the IP Office lines from the primary and secondary servers to each expansion system in the network.</li> <li>• <b>0</b> In a Server Edition/Select network, the ID 0 cannot be used.</li> <li>• <b>98888</b> For IP Office deployed in an Enterprise Branch environment, reserved for the SM line.</li> </ul>
<b>Number of Channels</b>	<p>Default = 20. Range 1 to 250; 1 to 500 for Select systems.</p> <p>Defines the number of operational channels that are available on this line.</p>
<b>Outgoing Channels</b>	<p>Default = 20, Range 0 to 250; 0 to 500 for Select systems.</p> <p>This defines the number of channels available, on this line, for outgoing calls. This should normally be the same as Number of Channels field, but can be reduced to ensure incoming calls cannot be blocked by outgoing calls.</p>
<b>Gateway</b>	
<b>Address</b>	<p>Default = Blank.</p> <p>Enter the IP address of the gateway device at the remote end. This address must not be shared by any other IP line (H.323, SIP, SES or IP DECT).</p>
<b>Location</b>	<p>Default = Cloud.</p> <p>Specify a location to associate the extension with a physical location. Associating an extension with a location:</p> <ul style="list-style-type: none"> <li>• Allows emergency services to identify the source of an emergency call.</li> <li>• Allows you to configure call admission control settings for the location.</li> </ul> <p>The drop down list contains all locations that have been defined on <b>Location   Location</b>.</p>

*Table continues...*

Field	Description
<p><b>Password</b></p> <p><b>Confirm Password</b></p>	<p>Default = Blank.</p> <p>The <b>Password</b> field is enabled when <b>Transport Type</b> is set to <b>WebSocket Server</b> or <b>WebSocket Client</b>.</p> <p>WebSockets are bi-directional HTTP or HTTPS communication pipes initiated from a client to a server. They permit clients behind local a firewall to traverse the internet to a server by using well known ports and protocols. A matching password must be set at each end of the line.</p>
<p><b>Port</b></p>	<p>When <b>Transport Type</b> is set to <b>Proprietary</b>, the default port is 1720 and cannot be changed.</p> <p>When <b>Transport Type</b> is set to <b>WebSocket Client</b>, the default port is 80.</p> <p>The <b>Port</b> field is not available when <b>Transport Type</b> is set to <b>WebSocket Server</b>. The HTTP and HTTPS receive ports are defined at the system level in the security settings <b>System Details</b> tab.</p>
<p><b>SCN Resiliency Options</b></p> <p>These options are only available when the <b>Networking Level</b> option is set to <b>SCN</b>. The intention of this feature is to attempt to maintain a minimal level of operation while problems with the local system are resolved.</p>	
<p><b>Supports Resiliency</b></p>	<p>Default = Off.</p> <p>These fields are available when <b>Networking Level</b> is set to <b>SCN</b>. When selected, all the available options are defaulted to <b>On</b>. When resiliency support is enabled on an IP Office Line in systems having IP extensions and the resilient systems do not have the corresponding H.323 or SIP registrars enabled, the IP Office system displays the error message -</p> <p>System is configured to support resiliency. Registration of IP extensions in failover requires the corresponding registrar to be enabled.</p>
<p><b>Backs up my IP Phones</b></p>	<p>Default = Off.</p> <p>When selected, the local system shares information about the registered phones and users on those phones with the backup system. If the local system is no longer visible to the phones, the phones will reregister with the backup system. When phones have registered with the backup system, they show an <b>R</b> on their display.</p> <p>Note that while IP Office line settings are mergeable, changed to this setting require the IP phones to be restarted in order to become aware of the change in their failover destination.</p> <p>If the setting <b>System   Telephony   Telephony   Phone Failback</b> is set to <b>Automatic</b>, and the phone's primary server has been up for more than 10 minutes, the backup system causes idle phones to perform a failback recovery to the original system.</p> <p>If using resilience backup to support Avaya IP phones, <b>Auto-create Extn</b> and <b>Auto-create User</b> should not be left enabled after initial configuration or any subsequent addition of new extensions and users. Leaving auto-create options enabled on a system that is a failover target may cause duplicate extension/user records on the multi-site network under multiple failure scenarios.</p>

*Table continues...*

Field	Description
<b>Backs up my Hunt Groups</b>	<p>Default = Off.</p> <p>This option is available only on the IP Office Line connecting the Server Edition Primary server to the Server Edition Secondary server.</p> <p>When selected, any hunt groups the local system is advertising to the network are advertised from the backup system when fallback is required. The trigger for this occurring is phones registered with the local system registering with the backup system, ie. <b>Backs up my IP Phones</b> above must also be enabled.</p> <p>When used, the only hunt group members that will be available are as follows:</p> <ul style="list-style-type: none"> <li>• If the group was a distributed hunt group, those members who were remote members on other systems are still visible within the network.</li> <li>• Any local members who have hot desked to another system still visible within the network.</li> </ul> <p>When the local system becomes visible to the backup system again, the groups will return to be advertised from the local system.</p>
<b>Backs up my Voicemail</b>	<p>Default = Off.</p> <p>This option can be used if the local system is hosting the Voicemail Pro server being used by the network. If selected, when the local system is no longer visible to the voicemail server, the backup system acts as host for the voicemail server. In a Server Edition network, this option is only available on the H.323 trunk from the Primary Server to the Secondary Server. It is assumed to be on and is automatically set by the Resilience Administration tool.</p> <p>The option requires the backup system to have licenses for the Voicemail Pro features that are required to operate during any fallback period.</p>
<b>Backs up my IP DECT Phones</b>	<p>Default = Off.</p> <p>This option is used for Avaya IP DECT phones registered with the system. When selected, it will share information about the registered phones and users on those phones with the backup system.</p> <p>If the local system is no longer visible to the phones, the phones will reregister with the backup system. The users who were currently on those phones will appear on the backup system as if they had hot desked. Note that when the local system is restored to the network, the phones will not automatically re-register with it. A phone reset via either a phone power cycle or using the System Status Application is required. When phones have registered with the backup system, they will show an <b>R</b> on their display.</p> <p> <b>Note:</b></p> <p>Only one IP Office Line can have this configuration parameter set to On.</p>

*Table continues...*

Field	Description
<b>Backs up my one-X Portal</b>	<p>Default = Off.</p> <p>This option is available on Server Edition Select deployments and only on the IP Office Line connecting the Server Edition Primary server to the Server Edition Secondary server.</p> <p>When set to On, this setting enables one-X Portal resiliency and turns on the backup one-X Portal on the Server Edition Secondary server.</p>
<b>Description</b>	<p>Default = Blank. Maximum 31 characters.</p> <p>Use this field to enter a description of this configuration.</p>

**Related links**

[IP Office Line](#) on page 384

**Short Codes**

Navigation: **Line | IP Office Line | Short Codes**

Incoming calls on IP Office Lines are not routed using Incoming Call Route settings.

Short codes can be added and edited using the **Add**, **Remove** and **Edit** buttons. Alternatively you can right-click on the list of existing short code to add and edit short codes.

These settings are not mergeable. Changes to these settings require a reboot of the system.

**Related links**

[IP Office Line](#) on page 384

**VoIP Settings**

Navigation: **Line | IP Office Line | VoIP Settings**

**Configuration Settings**

These settings are mergeable. Changes to these settings do not require a reboot of the system.

Field	Description
<b>Codec Selection</b>	<p>Default = System Default</p> <p>This field defines the codec or codecs offered during call setup. The available codecs in default preference order are:</p> <ul style="list-style-type: none"> <li>• <b>G.711 A-Law</b></li> <li>• <b>G.711 U-LAW</b></li> <li>• <b>G.729</b></li> <li>• <b>G.723.1</b></li> </ul> <p>Note that the default order for G.711 codecs varies to match the system's default companding setting. <b>G.723.1</b> is not supported on Linux based systems.</p> <p>The <b>G.722 64K</b> codec is also supported on IP500 V2 systems with IP500 VCM, IP500 VCM V2 or IP500 Combo cards. For Server Edition, it is supported on Primary Server, Secondary Server and Expansion System (L) systems and on Expansion System (V2) systems fitted with IP500 VCM, IP500 VCM V2 or IP500 Combo.</p> <p>The codecs available in this form are set through the codec list on <b>System   VoIP</b>.</p> <p>Within a network of systems, it is strongly recommended that all the systems and the lines connecting those systems use the same codecs.</p> <p>The options are:</p> <ul style="list-style-type: none"> <li>• <b>System Default</b> This is the default setting. When selected, the codec list below matches the codecs set in the system wide list.</li> <li>• <b>Custom</b> This option allows specific configuration of the codec preferences to be different from the system list. When <b>Custom</b> is selected, the list can be used to select which codecs are in the <b>Unused</b> list and in the <b>Selected</b> list and to change the order of the selected codecs.</li> </ul>

*Table continues...*

Field	Description
<b>Fax Transport Support</b>	<p>Default = None.</p> <p>IP500 V2 systems can terminate T38 fax calls. IP Office Linux systems can route the calls between trunks/terminals with compatible fax types. If the media is routed by IP Office between trunks/terminals with incompatible fax types or if fax is terminated by IP Office, IP Office will detect fax tones and renegotiate the call as needed.</p> <p>The options are:</p> <ul style="list-style-type: none"> <li>• <b>None</b> Select this option if fax is not supported by the line provider.</li> <li>• <b>Fax Relay</b> On IP Office Lines, fax relay is supported across multi-site network lines with <b>Fax Transport Support</b> selected. This will use 2 VCM channels in each of the systems. Fax relay is only supported on IP500 V2 systems with IP500 VCM, IP500 VCM V2 and or IP500 Combo cards. Not supported on Server Edition.</li> <li>• <b>G.711</b> G.711 is used for the sending and receiving of faxes.</li> <li>• <b>T38</b> T38 is used for the sending and receiving of faxes.</li> <li>• <b>T38 Fallback</b> When you enable this option, T38 is used for sending and receiving faxes. If the called destination does not support T38, the system will renegotiate to change the transport method to G.711.</li> </ul>
<b>Call Initiation Timeouts</b>	<p>Default = 4. Range = 1 to 99 seconds.</p> <p>This option sets how long the system should wait for a response to its attempt to initiate a call before following the alternate routes set in an ARS form.</p>
<b>Media Security</b>	<p>Default = Same as System.</p> <p>Secure RTP (SRTP) can be used between IP Offices to add additional security. These settings control whether SRTP is used for this line and the settings used for the SRTP. The options are:</p> <ul style="list-style-type: none"> <li>• <b>Same as System:</b> Matches the system setting at <b>System   VoIP Security</b>.</li> <li>• <b>Disabled:</b> Media security is not required. All media sessions (audio, video, and data) will be enforced to use RTP only.</li> <li>• <b>Preferred:</b> Media security is preferred. Attempt to use secure media first and if unsuccessful, fall back to non-secure media.</li> <li>• <b>Enforced:</b> Media security is required. All media sessions (audio, video, and data) will be enforced to use SRTP only.</li> </ul> <p> <b>Warning:</b> Selecting <b>Enforced</b> on a line or extension that does not support media security will result in media setup failures.</p>

*Table continues...*



Field	Description
<b>Advanced Media Security Options</b>	<p>Not displayed if <b>Media Security</b> is set to <b>Disabled</b>. The options are:</p> <ul style="list-style-type: none"> <li>• <b>Same as System:</b> Use the same settings as the system setting configured on <b>System   VoIP Security</b>.</li> <li>• <b>Encryptions:</b> Default = RTP This setting allows selection of which parts of a media session should be protected using encryption. The default is to encrypt just the RTP stream (the speech).</li> <li>• <b>Authentication:</b> Default = RTP and RTCP This setting allows selection of which parts of the media session should be protected using authentication.</li> <li>• <b>Replay Protection SRTP Window Size:</b> Default = 64. Currently not adjustable.</li> <li>• <b>Crypto Suites:</b> Default = SRTP_AES_CM_128_SHA1_80. There is also the option to select SRTP_AES_CM_128_SHA1_32.</li> </ul>
<b>VoIP Silence Suppression</b>	<p>Default = Off</p> <p>When selected, this option will detect periods of silence on any call over the line and will not send any data during those silent periods. This feature is not used on IP lines using <b>G.711</b> between systems. On trunk's between networked systems, the same setting should be set at both ends.</p>
<b>Out Of Band DTMF</b>	<p>Default = On.</p> <p>Out of Band DTMF is set to on and cannot be changed.</p>
<b>Allow Direct Media Path</b>	<p>Default = On</p> <p>This settings controls whether IP calls must be routed via the system or can be routed alternatively if possible within the network structure.</p> <ul style="list-style-type: none"> <li>• If enabled, IP calls can take routes other than through the system, removing the need for system resources such as voice compression channels. Both ends of the calls must support Direct Media and have compatible VoIP settings such as matching codec, etc. If otherwise, the call will remain routed via the system. Enabling this option may cause some vendors problems with changing the media path mid call.</li> <li>• If disabled, the call is routed via the system. In that case, RTP relay support may still allow calls between devices using the same audio codec to not require a voice compression channel.</li> </ul>

### Related links

[IP Office Line](#) on page 384

## T38 Fax

Navigation: [Line](#) | [IP Office Line](#) | [T38 Fax](#)

The settings are available only on IP500 V2 since it can terminate T38 fax. On the **VoIP** settings for the line type, **Fax Transport Support** must be set to **T38** or **T38 Fallback**.

These settings are mergeable.

Field	Description
<b>Use Default Values</b>	Default = On. If selected, all the fields are set to their default values and greyed out.
<b>T38 Fax Version</b>	Default = 3. During fax relay, the two gateways will negotiate to use the highest version which they both support. The options are: <ul style="list-style-type: none"> <li>• 0</li> <li>• 1</li> <li>• 2</li> <li>• 3</li> </ul>
<b>Transport</b>	Default = UDPTL (fixed). Only <b>UDPTL</b> is supported. <b>TCP</b> and <b>RTP</b> transport are not supported. For <b>UDPTL</b> , redundancy error correction is supported. Forward Error Correction (FEC) is not supported.
<b>Redundancy</b> Redundancy sends additional fax packets in order to increase the reliability. However increased redundancy increases the bandwidth required for the fax transport.	
<b>Low Speed</b>	Default = 0 (No redundancy). Range = 0 to 5. Sets the number of redundant T38 fax packets that should be sent for low speed V.21 T.30 fax transmissions.
<b>High Speed</b>	Default = 0 (No redundancy). Range = 0 to 5. Sets the number of redundant T38 fax packets that should be sent for V.17, V.27 and V.28 fax transmissions.
<b>TCF Method</b>	Default = Trans TCF. TCF = Training Check Frame.
<b>Max Bit Rate (bps)</b>	Default = 14400. Lower rates can be selected if the current rate is not supported by the fax equipment or is found to not be reliable.
<b>EFlag Start Timer (msecs)</b>	Default = 2600.
<b>EFlag Stop Timer (msecs)</b>	Default = 2300.
<b>Tx Network Timeout (secs)</b>	Default = 150.
<b>Scan Line Fix-up</b>	Default = On.
<b>TFOP Enhancement</b>	Default = On.
<b>Disable T30 ECM</b>	Default = Off. When selected, disabled the T.30 Error Correction Mode used for fax transmission.

*Table continues...*

Field	Description
<b>Disable EFlags For First DIS</b>	Default = Off.
<b>Disable T30 MR Compression</b>	Default = Off.
<b>NSF Override</b>	Default = Off. If selected, the NSF (Non-Standard Facility) information sent by the T38 device can be overridden using the values in the fields below. <b>Country Code:</b> Default = 0. <b>Vendor Code:</b> Default = 0.

### Related links

[IP Office Line](#) on page 384

---

## Control Unit

Navigation: **Control Unit | Unit**

The **Control Unit** form gives details of the system and some devices connected to or within the system. This includes some modules within the control nit as well as external expansion modules.

For Server Edition systems, for the Primary Server, Secondary Server and Expansion System (L) it shows details for the physical server platform and details for the IP Office Media service being hosted on that server. For the Expansion System (V2) it shows details of the IP500 V2 control unit and the cards installed into the control unit.

The **New** and **Delete** actions on this form have special functions.

- **New** This action is used to added a WAN3 expansion module. If when a WAN3 is added to the system, the WAN3 is not recognized following a system reboot, New on this form can be used to scan for the WAN3 module.
- **Delete** This action can only be used with external expansion modules. This action can only be used with external expansion modules attached to a system. The action should used with caution as deleting a module will also delete any extensions or lines associated with the module being deleted. If the module is physically present, default records are automatically recreated following a reboot.

These settings are not mergeable. Changes to these settings will require a reboot of the system.

Field	Description
Device Number	This is automatically allocated by the system.
Unit Type	The name of the device.
Version	The version of software running on each unit.

*Table continues...*

Field	Description
Serial Number	This is the number the system uses to tie a physical Control Unit to a device configuration (device number). For the control unit this is the MAC address. For a device connected to an Expansion port, it is the Expansion port number plus 1.
Unit IP Address	This field shows the IP address for the LAN1.
Interconnect Number	For external expansion modules this is the control unit expansion port used for connection. For other devices this is 0.
Module Number	For external expansion modules this is the control unit expansion port used for connection. For internal devices in the control unit, <b>Control Unit</b> is displayed.
Operating Mode	This field is available when a DS16B or DS30B digital expansion module is selected as the control unit. Select the operating mode based on the type of telephones deployed. <ul style="list-style-type: none"> <li>• <b>DS - 1400, 9500, 5400, 2400, 4400 Series Phones</b></li> <li>• <b>BST - T7000, M7000 Series Phones</b></li> </ul>

**Related links**

[Configuration Mode Field Descriptions](#) on page 197

## Extension



By default, each extension is normally associated with a user and uses that user's directory number and other setting. Users with a log in code can move between extensions by logging in and out, so the directory number is not a fixed property of the extension.

### Non-IP Extensions

Physical extension ports are either integral to the control unit or added by the installation of an analog or digital phone expansion module. Extension records are automatically created for each physical extension port within the system. These ports cannot be added or deleted manually. For Server Edition, non-IP extensions are only supported on Expansion System (V2) units.



#### Standard Telephone

A standard extension.



#### Quiet Headset

Used for analog extension devices that are permanently off-hook.

:

**IVR Port**

Used for analog ports connected to devices that require a specific disconnect clear signal at the end of each call.

**Paging Speaker**

An analog extension port set to be used as a paging speaker connection.

**FAX Machine**

Indicates that the extension is connected to a FAX machine.

**MOH Source**

Indicates that the extension is being used as a music on hold source.

**IP Extensions**

These are used for IP phone devices and VoIP applications.

**H.323 or SIP Extension**

This icon indicates an IP extension. IP extensions are either added manually or by the automatic detection of the phone being connected. IP extensions can also be added manually to support a third-party IP phone device. Note that third-party IP phone devices require entry of an IP End-Points license.

**IP DECT or SIP DECT**

An extension port manually added to match extensions within an Avaya IP DECT system connected to the system via an IP DECT line.

**Related links**

[Configuration Mode Field Descriptions](#) on page 197

[Extn](#) on page 397

[Analog](#) on page 400

[Extension VoIP](#) on page 403

[Extension T38 Fax](#) on page 410

[IP DECT Extension](#) on page 412

[SIP DECT Base Extension](#) on page 413

---

**Extn**

Navigation: [Extension](#) | [Extn](#)

**Additional configuration information**

The Caller Display Type setting controls the presentation of caller display information. For additional configuration information, see [Caller Display](#) on page 613.

This type of configuration record can be saved as a template and new records created from a template. See [Working with Templates](#) on page 600.

### Configuration Settings

These settings are mergeable except **Base Extension** and **Caller Display Type** which require a system reboot.

Field	Description								
<b>Extension ID</b>	The physical ID of the extension port. Except for IP extensions, this settings is allocated by the system and is not configurable.								
<b>Base Extension</b>	<p>Range = 2 to 15 digits.</p> <p>This is the directory number of the extension's default associated user if one is required. The field does not have to match a user, in which case user's need to login to use the extension.</p> <p>The field can be left blank for digital and analogue extensions, creating an extension where users are forced to login but the extension has no default associated user. This option is not supported for IP and CTI extensions.</p> <p>Following a restart, the system will attempt to log in the user with the same extension number (if they are not already logged in elsewhere in the multi-site network). This does not occur if that user is set to <b>Force Login</b>.</p> <p>If another user logs onto an extension, when they log out, the extension returns to its default associated user unless they have logged in elsewhere or are set to <b>Force Login</b>.</p>								
<b>Phone Password</b>	<p>Default = Blank. Range = Up to 31 digits.</p> <p>H.323 Extensions only. Does not apply to DECT phones.</p> <p>The password that must be entered as part of phone registration. This password is used to secure registration of H.323 phones when there is no matching user to authenticate against. Required if Media Security is enabled.</p>								
<b>Caller Display Type</b>	<p>Default = On.</p> <p>Controls the presentation of caller display information for analog extensions. For digital and IP extensions, this value is fixed as <b>On</b>. The table below lists the supported options, all others are currently not used and default to matching <b>UK</b>.</p> <table border="1"> <thead> <tr> <th>Type</th> <th>Description</th> </tr> </thead> <tbody> <tr> <td><b>Off</b></td> <td>Disables caller display.</td> </tr> <tr> <td><b>On</b></td> <td>Enables caller display using the caller display type appropriate to the System Locale, see <i>Avaya IP Office™ Platform Locale Settings</i>. If a different setting is required it can be selected from the list of supported options. For an analog extension connected to a fax server or other device that requires the pass through of DTMF tones, select DTMFF.</td> </tr> <tr> <td><b>UK</b></td> <td>FSK before the first ring conforming to BT SIN 227. Name and number.</td> </tr> </tbody> </table>	Type	Description	<b>Off</b>	Disables caller display.	<b>On</b>	Enables caller display using the caller display type appropriate to the System Locale, see <i>Avaya IP Office™ Platform Locale Settings</i> . If a different setting is required it can be selected from the list of supported options. For an analog extension connected to a fax server or other device that requires the pass through of DTMF tones, select DTMFF.	<b>UK</b>	FSK before the first ring conforming to BT SIN 227. Name and number.
Type	Description								
<b>Off</b>	Disables caller display.								
<b>On</b>	Enables caller display using the caller display type appropriate to the System Locale, see <i>Avaya IP Office™ Platform Locale Settings</i> . If a different setting is required it can be selected from the list of supported options. For an analog extension connected to a fax server or other device that requires the pass through of DTMF tones, select DTMFF.								
<b>UK</b>	FSK before the first ring conforming to BT SIN 227. Name and number.								

Table continues...

Field	Description													
	<b>UK20</b>	As per UK but with a maximum length of 20 characters. Name and number.												
	<b>DTMFA</b>	Caller ID in the DTMF pattern A<caller ID>C. Number only.												
	<b>DTMFB</b>	Caller ID in DTMF after call connection. Number only.												
	<b>DTMFC</b>	Caller ID in the DTMF pattern A<caller ID>#. Number only.												
	<b>DTMFF</b>	Sends the called number in DTMF after call connection. Number only. Used for fax servers. When calls are delivered via a hunt group it is recommended that hunt group queuing is not used. If hunt group queuing is being used, set the Queue Type to Assign Call on Agent Alert.												
	<b>DTMFD</b>	Caller ID in the DTMF pattern D<caller ID>C. Number only.												
	<b>FSKA</b>	Variant of UK used for BT Relate 1100 phones. Name and number.												
	<b>FSKB</b>	ETSI specification with 0.25 second leading ring. Name and number.												
	<b>FSKC</b>	ETSI specification with 1.2 second leading ring. Name and number.												
	<b>FSKD</b>	Conforms to Belcore specification. Name and number.												
<b>Reset Volume after Calls</b>	Default = Off. Resets the phone's handset volume after each call. This option is supported on Avaya 1400, 1600, 2400, 4400, 4600, 5400, 5600, 6400, 9500 and 9600 Series phones.													
<b>Device Type</b>	<p>This field indicates, the last known type of phone connected to the extension port.</p> <ul style="list-style-type: none"> <li>• Analogue extension ports always report as <b>Analog Handset</b> since the presence or absence of actual analog phone cannot be detected.</li> <li>• Digital extension ports report the type of digital phone connected or <b>Unknown digital handset</b> if no phone is detected.</li> <li>• H.323 extensions report the type of IP phone registered or <b>Unknown H.323 handset</b> if no phone is currently registered as that extension.</li> <li>• SIP extensions report the type of SIP phone registered or <b>Unknown SIP device</b> if no SIP device is currently registered as that extension. Applications such as Avaya Workplace Client and one-X Mobile Preferred that do not use extension records also display Device type as <b>Unknown SIP device</b>.</li> </ul> <p>For some types of phone, the phone can only report its general type to the system but not the specific model. When that is the case, the field acts as a drop-down to allow selection of a specific model. The value selected here is also reported in other applications such as the System Status Application, SNMP, etc.</p> <table border="1"> <thead> <tr> <th>Default Type</th> <th>Possible Phone Models</th> </tr> </thead> <tbody> <tr> <td><b>T7100</b></td> <td>M7100, M7100N, T7100, Audio Conferencing Unit.</td> </tr> <tr> <td><b>T7208</b></td> <td>M7208, M7208N, T7208.</td> </tr> <tr> <td><b>M7310</b></td> <td>M7310, M7310N, T7406, T7406E.</td> </tr> <tr> <td><b>M7310BLF</b></td> <td>M7310BLF, T7316.</td> </tr> <tr> <td><b>M7324</b></td> <td>M7324, M7324N.</td> </tr> </tbody> </table>		Default Type	Possible Phone Models	<b>T7100</b>	M7100, M7100N, T7100, Audio Conferencing Unit.	<b>T7208</b>	M7208, M7208N, T7208.	<b>M7310</b>	M7310, M7310N, T7406, T7406E.	<b>M7310BLF</b>	M7310BLF, T7316.	<b>M7324</b>	M7324, M7324N.
Default Type	Possible Phone Models													
<b>T7100</b>	M7100, M7100N, T7100, Audio Conferencing Unit.													
<b>T7208</b>	M7208, M7208N, T7208.													
<b>M7310</b>	M7310, M7310N, T7406, T7406E.													
<b>M7310BLF</b>	M7310BLF, T7316.													
<b>M7324</b>	M7324, M7324N.													

*Table continues...*

Field	Description
<b>Location</b>	<p>Specify a location to associate the extension with a physical location. Associating an extension with a location allows emergency call routing using settings specific to that location. The drop down list contains all locations that have been defined in the Location page.</p> <p>The display of location based time is only supported on 1100, 1200, 1600 and 9600 Series phones and D100, E129 and B179 telephones.</p>
<b>Fallback as Remote Worker</b>	<p>Default = Auto.</p> <p>Determines what fallback address is used for Remote Worker phone resiliency.</p> <p>The options are:</p> <ul style="list-style-type: none"> <li>• <b>Auto</b>: Use the fallback address configured on the IP Office Line providing the service.</li> <li>• <b>No</b>: Use the alternate gateway private address.</li> <li>• <b>Yes</b>: Use the alternate gateway public address.</li> </ul>
<b>Module</b>	<p>This field indicates the external expansion module on which the port is located. <b>BP</b> indicates an analog phone extension port on the base or control unit. <b>BD</b> indicates a digital station (DS) port on the control unit. For an IP500 V2 control unit, <b>BD</b> and <b>BP</b> is also followed by the slot number. VoIP extensions report as <b>0</b>.</p>
<b>Port</b>	<p>This field indicates the port number on the <b>Module</b> indicated above. VoIP extensions report as <b>0</b>.</p>
<b>Disable Speakerphone</b>	<p>Default = Off (Speakerphone enabled).</p> <p>When selected, disables the fixed <b>SPEAKER</b> button if present on the phone using this extension port. Only supported on Avaya DS, TCM and H.323 IP phones. An audible beep is sounded when a disabled <b>SPEAKER</b> button is pressed. Incoming calls such as pages and intercom calls are still connected but the speech path is not audible until the user goes off-hook using the handset or headset. Similarly calls made or answered using other buttons on the phone are not audible unless the user goes off-hook using the handset or headset. Currently connected calls are not affected by changes to this setting.</p>

**Related links**

[Extension](#) on page 396

## Analog

Navigation: [Extension](#) | [Analog Extension](#) | [Analog](#)

This tab contains settings that are applicable to analog extensions. These extensions are provided by ports marked as **POT** or **PHONE** on control units and expansion modules.

These settings are not mergeable. Changes to these settings will require a reboot of the system.



Field	Description
<b>Equipment Classification:</b> Default = Standard Telephone. Only available for analog extension ports. Note that changes to this setting are mergeable.	
<b>Quiet Headset</b>	On extensions set to <b>Quiet Headset</b> , the audio path is disabled when the extension is idle. Ringing is presented in the audio path. Caller ID is not supported on the phone. This option can be used with analog extensions where the handset is replaced by a headset since in such a scenario audio is only desired when a call is connected. Since the audio path is disabled when idle, the <b>Quiet Headset</b> extension cannot dial digits to make calls. Therefore to make and answer calls this option is typically used with the user Offhook Station (User   Telephony   Call Settings) setting which allows the extension user to make and answer calls using applications.
<b>Paging Speaker</b>	Used for analog ports connected to a paging amplifier. This extension will present busy and cannot be called or be used to make calls. It can only be accessed using Dial Paging features.  When using a UPAM connected to an analog extension port, the extension's Equipment Classification (Extension   Analog) should be set to <b>IVR Port</b> and not <b>Paging Speaker</b> .
<b>Standard Telephone</b>	Use for normal analog phones.
<b>Door Phone 1/Door Phone 2</b>	These two options are currently not used and so are grayed out.
<b>IVR Port</b>	Used for analog ports connected to devices that require a disconnect clear signal (ie. a break in the loop current) at the end of each call. When selected the <b>Disconnect Pulse Width</b> is used.
<b>FAX Machine</b>	If fax Relay is being used, this setting should be selected on any analog extension connected to an analog fax machine. This setting can also be used with SIP trunks.
<b>MOH Source</b>	If selected, the port can be used as a music on hold source in the Tones and Music settings. An extension set as a music on hold source cannot make or receive calls. The audio input can be monitored through the extension music on hold controls. A suitable interface device is required to provide the audio input to the extension port. It must look to the system like an off-hook analog phone. For example a transformer with a 600 Ohm winding (such as a Bogen WMT1A) or a dedicated MoH device with a 600Ohm output designed for connection to a PBX extension port which is providing loop current can be used.
<b>Flash Hook Pulse Width</b> The following options are only available for analog extension ports. They define the length of loop break that will be considered a time break recall (TBR) signal.	
<b>Use System Defaults</b>	Default = Selected (On) Use the default values appropriate to the system's locale.
<b>Minimum Width</b>	Range = 20 to 2540 milliseconds. Minimum hook flash length used if <b>Use System Defaults</b> is not selected. Shorter breaks are ignored a glitches.

Table continues...

Field	Description	
<b>Maximum Width</b>	<p>Range = 30 to 2550 milliseconds.</p> <p>Maximum hook flash length used if <b>Use System Defaults</b> is not selected. Longer breaks are treated as clearing.</p>	
<b>Disconnect Pulse Width</b>	<p>Default = 0ms. Range = 0 to 2550ms</p> <p>This setting is used with analog extensions where the <b>Equipment Classification</b> above has been set to <b>IVR Port</b>. It sets the length of loop current break used to indicate call clearing.</p>	
<b>Message Waiting Lamp Indication Type</b>	<p>Default = None</p> <p>Allows the selection of the message waiting indication (MWI) mode for analog and IP DECT extensions.</p> <p>For control unit and Phone V1 module analog extensions, the options are:</p> <ul style="list-style-type: none"> <li>• <b>101V</b></li> <li>• <b>51V Stepped</b></li> <li>• <b>81V</b></li> <li>• <b>Bellcore FSK</b></li> <li>• <b>Line Reversal A</b></li> <li>• <b>Line Reversal B</b></li> <li>• <b>None</b></li> <li>• <b>On</b></li> </ul> <p>For Phone V2 external module extensions and IP500 Phone base cards, the additional option <b>101V</b> is available.</p> <p>For IP500 V2 systems, if the option <b>Restrict Analog Extension Ringer Voltage</b> is selected (<b>System   Telephony   Telephony</b>), the MWI options are restricted to:</p> <ul style="list-style-type: none"> <li>• <b>Line Reversal A</b></li> <li>• <b>Line Reversal B</b></li> <li>• <b>None</b></li> </ul> <p>Any extensions set to another option are forced to <b>Line Reversal A</b>.</p> <p><b>On</b> defaults the message waiting indication as follows using the system locale.</p>	
	<b>Locale</b>	<b>'On' =</b>
	Argentina, Australia, Brazil, Canada, Chile, China, Colombia, Japan, Korea, Mexico, New Zealand, Peru, Russia, Saudi Arabia, South Africa, Spain, United States, Venezuela	51V Stepped

*Table continues...*

Field	Description
	<p>Bahrain, Belgium, Denmark, Egypt, Finland, France, Germany, Greece, Hong Kong, Hungary, Iceland, Italy, India, Kuwait, Morocco, Netherlands, Norway, Oman, Pakistan, Poland, Portugal, Qatar, Singapore, Sweden, Switzerland, Taiwan, Turkey, United Arab Emirates, United Kingdom</p> <p>On = 101V on Phone V2 modules and IP500 Phone cards, otherwise 81V.</p>
<b>Hook Persistency:</b>	<p>Default = 100ms. Range = 50 to 255ms.</p> <p>Defines the time frame (in milliseconds) in which the system will wait before determining that the phone is off-hook.</p>

**Related links**

[Extension](#) on page 396

## Extension VoIP

This tab is only available for H.323 and SIP extensions. The settings available will vary depending on the extension type.

**Related links**

[Extension](#) on page 396

[Extension H.323 VoIP](#) on page 403

[SIP Extension VoIP](#) on page 407

## Extension H.323 VoIP

Navigation: [Extension](#) | [H323 Extension](#) | [VoIP](#)

These settings are shown for a H.323 IP extension.

These settings are not mergeable. Changes to these settings require a reboot of the system.

Field	Description
<b>IP Address</b>	<p>Default = 0.0.0.0</p> <p>The IP address of the phone. The default setting accepts connection from any address. For phones using DHCP, the field is not updated to show the IP address being used by the phone.</p> <p>The <b>IP Address</b> field can be used to restrict the the source IP address that can be used by a Remote H.323 Extension. However, it should not be used in the case where there is more than one remote extension behind the domestic router.</p>
<b>MAC Address</b>	<p>Default = 000000000000 (Grayed out)</p> <p>This field is grayed out and not used.</p>

*Table continues...*



Field	Description
<b>Codec Selection</b>	<p>Default = System Default This field defines the codec or codecs offered during call setup.</p> <p>The supported codecs (in default preference order) are: <b>G.711 A-Law</b>, <b>G.711 U-Law</b>, <b>G.722</b>, <b>G.729</b> and <b>G.723.1</b>. The default order for G.711 codecs will vary to match the system's default companding setting. <b>G.723.1</b> and <b>G.729b</b> are not supported on Linux based systems.</p> <p>The codecs available to be used are set through the <b>System Codec</b> list (System   System Codec). The options are:</p> <ul style="list-style-type: none"> <li>• <b>System Default:</b> This is the default setting. When selected, the codec list below show matches the codecs set in the system wide <b>Default Selection</b> list (System   Codecs).</li> <li>• <b>Custom:</b> This option allows specific configuration of the codec preferences to be different from the system <b>Default Selection</b> list. When <b>Custom</b> is selected, the list can be used to select which codecs are in the <b>Unused</b> list and in the <b>Selected</b> list and to change the order of the selected codecs.</li> </ul>
<b>TDM   IP Gain</b>	<p>Default = Default (0dB). Range = -31dB to +31dB.</p> <p>Allows adjustment of the gain on audio from the system TDM interface to the IP connection. This field is not shown on Linux based platforms.</p>
<b>IP   TDM Gain</b>	<p>Default = Default (0dB). Range = -31dB to +31dB.</p> <p>Allows adjustment of the gain on audio from the IP connection to the system TDM interface. This field is not shown on Linux based platforms.</p>
<b>Supplementary Services</b>	<p>Default = H450.</p> <p>Selects the supplementary service signaling method for use with non-Avaya IP devices. Options are <b>None</b>, <b>QSIG</b> and <b>H450</b>. For H450, hold and transfer are supported. Note that the selected method must be supported by the remote end.</p>
<b>Media Security</b>	<p>Default = Same as System.</p> <p>These settings control whether SRTP is used for this extension and the settings used for the SRTP. The options are:</p> <ul style="list-style-type: none"> <li>• <b>Same as System:</b> Matches the system setting at <b>System   VoIP Security</b>.</li> <li>• <b>Disabled:</b> Media security is not required. All media sessions (audio, video, and data) will be enforced to use RTP only.</li> <li>• <b>Preferred:</b> Media security is preferred. Attempt to use secure media first and if unsuccessful, fall back to non-secure media.</li> <li>• <b>Enforced:</b> Media security is required. All media sessions (audio, video, and data) will be enforced to use SRTP only.</li> </ul> <p> <b>Warning:</b></p> <p>Selecting <b>Enforced</b> on a line or extension that does not support media security will result in media setup failures.</p>

Table continues...

Field	Description
<b>Advanced Media Security Options</b>	<p>Not displayed if <b>Media Security</b> is set to <b>Disabled</b>. The options are:</p> <ul style="list-style-type: none"> <li>• <b>Same as System:</b> Use the same settings as the system setting configured on <b>System   VoIP Security</b>.</li> <li>• <b>Encryptions:</b> Default = RTP This setting allows selection of which parts of a media session should be protected using encryption. The default is to encrypt just the RTP stream (the speech).</li> <li>• <b>Authentication:</b> Default = RTP and RTCP This setting allows selection of which parts of the media session should be protected using authentication.</li> <li>• <b>Replay Protection SRTP Window Size:</b> Default = 64. Currently not adjustable.</li> <li>• <b>Crypto Suites:</b> Default = SRTP_AES_CM_128_SHA1_80. There is also the option to select SRTP_AES_CM_128_SHA1_32.</li> </ul>
<b>VoIP Silence Suppression</b>	<p>Default = Off</p> <p>When selected, this option will detect periods of silence on any call over the line and will not send any data during those silent periods. This feature is not used on IP lines using <b>G.711</b> between systems. On trunk's between networked systems, the same setting should be set at both ends.</p>
<b>Enable FastStart for non-Avaya IP Phones</b>	<p>Default = Off</p> <p>A fast connection procedure. Reduces the number of messages that need to be exchanged before an audio channel is created.</p>
<b>Out of Band DTMF</b>	<p>Default = On</p> <p>When on, DTMF is sent as a separate signal ("Out of Band") rather than as part of the encoded voice stream ("In Band"). The "Out of Band" signaling is inserted back into the audio by the remote end. This is recommended for low bit-rate compression modes such as G.729 and G.723 where DTMF in the voice stream can become distorted.</p> <p>For Avaya 1600, 4600, 5600 and 9600 Series phones, the system will enforce the appropriate setting for the phone type.</p>

*Table continues...*

Field	Description
<b>Requires DTMF</b>	<p>Default = Off.</p> <p>This field is displayed when <b>System   VoIP   Ignore DTMF Mismatch for Phones</b> is set to <b>On</b>. It can be used to allow direct media connections between devices despite the devices having differing DTMF setting.</p> <p>When <b>Requires DTMF</b> is set to <b>Off</b>, during the checks for direct media, the system ignores the DTMF checks if the call is between two VoIP phones. The two phones can be located on different systems in a Server Edition or SCN deployment. Set to <b>On</b> if the extension needs to receive DTMF signals.</p> <p>SIP endpoints using simultaneous login, which do not have physical extensions in the configuration, are treated by the system as not requiring DTMF.</p> <p> <b>Note:</b></p> <ul style="list-style-type: none"> <li>• Direct media may still not be possible if other settings, such as codecs, NAT settings, or security settings, are mismatched.</li> <li>• When the system setting is set to <b>On</b>, the extension setting is ignored for contact center applications. Contact center application SIP extensions are always treated as requiring DTMF.</li> </ul>
<b>Local Tones</b>	<p>Default = Off</p> <p>When selected, the H.323 phones generate their own tones.</p>
<b>Allow Direct Media Path</b>	<p>Default = On</p> <p>This settings controls whether IP calls must be routed via the system or can be routed alternatively if possible within the network structure.</p> <ul style="list-style-type: none"> <li>• If enabled, IP calls can take routes other than through the system, removing the need for system resources such as voice compression channels. Both ends of the calls must support Direct Media and have compatible VoIP settings such as matching codec, etc. If otherwise, the call will remain routed via the system. Enabling this option may cause some vendors problems with changing the media path mid call. Disabling the extension's <b>Requires DTMF</b> setting above allows it to attempt direct media even if the other phone has differing DTMF settings.</li> <li>• If disabled, the call is routed via the system. In that case, RTP relay support may still allow calls between devices using the same audio codec to not require a voice compression channel.</li> </ul>

*Table continues...*

Field	Description
<b>Reserve License</b>	<p>Default = None. Each Avaya IP phones requires an Avaya IP Endpoint license. Each non-Avaya IP phones requires an 3rd Party IP Endpoint license. Normally these licenses are issued in the order that devices register. This option allows this extension to be pre-licensed before the device has registered. This helps prevent a previously licensed phone becoming unlicensed following a system restart if unlicensed devices are also present. The options are:</p> <ul style="list-style-type: none"> <li>• <b>Reserve Avaya IP Endpoint License</b></li> <li>• <b>Reserve 3rd Party IP Endpoint License</b></li> <li>• <b>Both</b></li> <li>• <b>None</b></li> </ul> <p>Note that when WebLM licensing is enabled, this field is automatically set to <b>Reserve Avaya IP Endpoint License</b>. The <b>None</b> option is not available.</p>

### Related links

[Extension VoIP](#) on page 403

## SIP Extension VoIP

Navigation: [Extension](#) | [SIP Extension](#) | [VoIP](#)

These settings are shown for SIP IP extensions. For example for J100 Series phones.

Field	Description
<b>IP Address</b>	<p>Default = 0.0.0.0</p> <p>The IP address of the phone. The default setting accepts connection from any address. If an address is entered, registration is only accepted from a device with that address.</p>
<b>Reserve License</b>	<p>Default = None. Each Avaya IP phones requires an Avaya IP Endpoint license. Each non-Avaya IP phones requires an 3rd Party IP Endpoint license. Normally these licenses are issued in the order that devices register. This option allows this extension to be pre-licensed before the device has registered. This helps prevent a previously licensed phone becoming unlicensed following a system restart if unlicensed devices are also present. The options are:</p> <ul style="list-style-type: none"> <li>• <b>Reserve Avaya IP Endpoint License</b></li> <li>• <b>Reserve 3rd Party IP Endpoint License</b></li> <li>• <b>Both</b></li> <li>• <b>None</b></li> </ul> <p>Note the following:</p> <ul style="list-style-type: none"> <li>• When WebLM licensing is enabled, this field is automatically set to <b>Reserve Avaya IP Endpoint License</b>. The <b>Both</b> and <b>None</b> options are not available.</li> <li>• When the <b>Profile</b> of the corresponding user is set to <b>Centralized User</b>, this field is automatically set to <b>Centralized Endpoint License</b> and cannot be changed.</li> </ul>

*Table continues...*

Field	Description
<b>VoIP Silence Suppression</b>	<p>Default = Off</p> <p>When selected, this option will detect periods of silence on any call over the line and will not send any data during those silent periods. This feature is not used on IP lines using <b>G.711</b> between systems. On trunk's between networked systems, the same setting should be set at both ends</p>
<b>Fax Transport:</b>	<p>Default = Off.</p> <p>This option is only available if <b>Re-Invite Supported</b> is selected. When enabled, the system performs fax tone detection on calls routed via the line and, if fax tone is detected, renegotiates the call codec as configured below. The SIP line provider must support the selected fax method and Re-Invite.</p> <p>For systems in a network, fax relay is supported for fax calls between the systems.</p> <p>The options are:</p> <ul style="list-style-type: none"> <li>• <b>None</b> Select this option if fax is not supported by the line provider.</li> <li>• <b>G.711</b> G.711 is used for the sending and receiving of faxes.</li> <li>• <b>T38</b> T38 is used for the sending and receiving of faxes.</li> <li>• <b>T38 Fallback</b> When you enable this option, T38 is used for sending and receiving faxes on a SIP line. If the called destination does not support T38, the system will send a re-invite to change the transport method to G.711.</li> </ul>
<b>DTMF Transport</b>	<p>Default = RFC2833.</p> <p>This setting is used to select the method by which DTMF key presses are signalled to the remote end. The supported options are <b>In Band</b>, <b>RFC2833</b> or <b>Info</b>.</p>
<b>Requires DTMF</b>	<p>Default = Off.</p> <p>This field is displayed when <b>System Settings &gt; System &gt; VoIP &gt; Ignore DTMF Mismatch for Phones</b> is set to <b>On</b>. It can be used to allow direct media connections between devices despite the devices having differing DTMF setting.</p> <p>When <b>Requires DTMF</b> is set to <b>Off</b>, during the checks for direct media, the system ignores the DTMF checks if the call is between two VoIP phones. Set to <b>On</b> if the extension needs to receive DTMF signals.</p> <p>SIP endpoints using simultaneous login, which do not have physical extensions in the configuration, are treated by the system as not requiring DTMF.</p> <p> <b>Note:</b></p> <ul style="list-style-type: none"> <li>• Direct media may still not be possible if other settings, such as codecs, NAT settings, or security settings, are mismatched.</li> </ul>
<b>Local Hold Music</b>	<p>Default = Off.</p> <p>When enabled, the extension plays local music when on HOLD.</p> <p>If <b>System Settings &gt; Line &gt; Add/Edit Trunk Line &gt; SIP Line &gt; SIP Advanced &gt; Local Hold Music</b> is enabled, the extension <b>Local Hold Music</b> must be disabled to play far end music to the extension.</p>

*Table continues...*



Field	Description
<b>Allow Direct Media Path</b>	<p>Default = On</p> <p>This settings controls whether IP calls must be routed via the system or can be routed alternatively if possible within the network structure.</p> <ul style="list-style-type: none"> <li>• If enabled, IP calls can take routes other than through the system, removing the need for system resources such as voice compression channels. Both ends of the calls must support Direct Media and have compatible VoIP settings such as matching codec, etc. If otherwise, the call will remain routed via the system. Enabling this option may cause some vendors problems with changing the media path mid call. Disabling the extension's <b>Requires DTMF</b> setting above allows it to attempt direct media even if the other phone has differing DTMF settings.</li> <li>• If disabled, the call is routed via the system. In that case, RTP relay support may still allow calls between devices using the same audio codec to not require a voice compression channel.</li> </ul>
<b>RE-Invite Supported</b>	<p>Default = On.</p> <p>When enabled, <b>Re-Invite</b> can be used during a session to change the characteristics of the session. For example, when the target of an incoming call or a transfer does not support the codec originally negotiated on the trunk. Requires the ITSP to also support <b>Re-Invite</b>. This setting must be enabled for video support.</p>
<b>Codec Lockdown</b>	<p>Default = Off.</p> <p>Supports RFC 3264 Section 10.2 when <b>RE-Invite Supported</b> is enabled. In response to a SIP offer with a list of codecs supported, some SIP user agents supply a SDP answer that also lists multiple codecs. This means that the user agent may switch to any of those codecs during the session without further negotiation. The system does not support multiple concurrent codecs for a session, so loss of speech path will occur if the codec is changed during the session. If codec lockdown is enabled, when the system receives an SDP answer with more than one codec from the list of offered codecs, it sends an extra re-INVITE using just a single codec from the list and resubmits a new SDP offer with just the single chosen codec.</p>
<b>3rd Party Auto Answer</b>	<p>Default = None.</p> <p>This setting applies to 3rd party standard SIP extensions. The options are:</p> <ul style="list-style-type: none"> <li>• <b>RFC 5373</b>: Add an RFC 5373 auto answer header to the INVITE.</li> <li>• <b>answer-after</b>: Add answer-after header.</li> <li>• <b>device auto answers</b>: IP Office relies on the phone to auto answer calls.</li> </ul>

*Table continues...*

Field	Description
<b>Media Security</b>	<p>Default = Same as System.</p> <p>These settings control whether SRTP is used for this extension and the settings used for the SRTP. The options are:</p> <ul style="list-style-type: none"> <li>• <b>Same as System:</b> Matches the system setting at <b>System   VoIP Security</b>.</li> <li>• <b>Disabled:</b> Media security is not required. All media sessions (audio, video, and data) will be enforced to use RTP only.</li> <li>• <b>Preferred:</b> Media security is preferred. Attempt to use secure media first and if unsuccessful, fall back to non-secure media.</li> <li>• <b>Enforced:</b> Media security is required. All media sessions (audio, video, and data) will be enforced to use SRTP only.</li> </ul> <p> <b>Warning:</b>                      Selecting <b>Enforced</b> on a line or extension that does not support media security will result in media setup failures.</p>
<b>Codec Selection</b>	<p>Default = System Default</p> <p>This field defines the codec or codecs offered during call setup.</p> <p>The available codecs in default preference order are: <b>G.711 A-Law</b>, <b>G.711 ULAW</b>, <b>G.729</b> and <b>G.723.1</b>. Note that the default order for G.711 codecs will vary to match the system's default companding setting.</p> <p>The <b>G.722 64K</b> codec is also supported.</p> <p>The codecs available to be used are set through the <b>System Codec</b> list (<b>System   System Codec</b>). The options are:</p> <ul style="list-style-type: none"> <li>• <b>System Default:</b> This is the default setting. When selected, the codec list below show matches the codecs set in the system wide <b>Default Selection</b> list (<b>System   Codecs</b>).</li> <li>• <b>Custom:</b> This option allows specific configuration of the codec preferences to be different from the system <b>Default Selection</b> list. When <b>Custom</b> is selected, the list can be used to select which codecs are in the <b>Unused</b> list and in the <b>Selected</b> list and to change the order of the selected codecs.</li> </ul>

**Related links**

[Extension VoIP](#) on page 403

---

## Extension T38 Fax

Navigation: **Extension | SIP Extension | T38 Fax**

The settings are available only on IP500 V2 since it can terminate T38 fax. On the **VoIP** settings for the line type, **Fax Transport Support** must be set to **T38** or **T38 Fallback**.

These settings are mergeable.

Field	Description
<b>Use Default Values</b>	Default = On. If selected, all the fields are set to their default values and greyed out.
<b>T38 Fax Version</b>	Default = 3. During fax relay, the two gateways will negotiate to use the highest version which they both support. The options are: <ul style="list-style-type: none"> <li>• 0</li> <li>• 1</li> <li>• 2</li> <li>• 3</li> </ul>
<b>Transport</b>	Default = UDPTL (fixed). Only <b>UDPTL</b> is supported. <b>TCP</b> and <b>RTP</b> transport are not supported. For <b>UDPTL</b> , redundancy error correction is supported. Forward Error Correction (FEC) is not supported.
<b>Redundancy</b>	
Redundancy sends additional fax packets in order to increase the reliability. However increased redundancy increases the bandwidth required for the fax transport.	
<b>Low Speed</b>	Default = 0 (No redundancy). Range = 0 to 5. Sets the number of redundant T38 fax packets that should be sent for low speed V.21 T.30 fax transmissions.
<b>High Speed</b>	Default = 0 (No redundancy). Range = 0 to 5. Sets the number of redundant T38 fax packets that should be sent for V.17, V.27 and V.28 fax transmissions.
<b>TCF Method</b>	Default = Trans TCF. TCF = Training Check Frame.
<b>Max Bit Rate (bps)</b>	Default = 14400. Lower rates can be selected if the current rate is not supported by the fax equipment or is found to not be reliable.
<b>EFlag Start Timer (msecs)</b>	Default = 2600.
<b>EFlag Stop Timer (msecs)</b>	Default = 2300.
<b>Tx Network Timeout (secs)</b>	Default = 150.
<b>Scan Line Fix-up</b>	Default = On.
<b>TFOP Enhancement</b>	Default = On.
<b>Disable T30 ECM</b>	Default = Off. When selected, disabled the T.30 Error Correction Mode used for fax transmission.

*Table continues...*

Field	Description
<b>Disable EFlags For First DIS</b>	Default = Off.
<b>Disable T30 MR Compression</b>	Default = Off.
<b>NSF Override</b>	Default = Off. If selected, the NSF (Non-Standard Facility) information sent by the T38 device can be overridden using the values in the fields below. <b>Country Code:</b> Default = 0. <b>Vendor Code:</b> Default = 0.

**Related links**

[Extension](#) on page 396

---

## IP DECT Extension

Navigation: **Extension | IP DECT Extension**

IP DECT extensions are created manually after an IP DECT line has been added to the configuration or added automatically as DECT handsets subscribe to the DECT system.

These settings are mergeable with the exception of the **Reserve License** setting. Changing the **Reserve License** settings requires a reboot of the system.

Field	Description
<b>DECT Line ID</b>	Use the drop-down list to select the IP DECT line from the system to the Avaya IP DECT system.
<b>Message Waiting Lamp Indication Type</b>	Default = On Allows selection of the message waiting indication to use with the IP DECT extension. The options are: <ul style="list-style-type: none"> <li>• None</li> <li>• On</li> </ul>
<b>Reserve License</b>	Default = None. Avaya IP phones require an Avaya IP Endpoint license in order to register with the system. Normally licenses are issued in the order that devices register. This option allows this extension to be pre-licensed before the device has registered. The options are <ul style="list-style-type: none"> <li>• Reserve Avaya IP Endpoint License</li> <li>• None</li> </ul> Note that when WebLM licensing is enabled, this field is automatically set to <b>Reserve Avaya IP Endpoint License</b> and cannot be changed.

The additional fields below depend on whether the IP DECT line has **Enable Provisioning** selected.

Field	Description
<b>Enable Provisioning Not Selected</b>	
<b>Handset Type</b>	Default = Unknown Correct selection of the handset type allows application of appropriate settings for the handset display and buttons. Selectable handset types are <b>3720</b> , <b>3725</b> , <b>3740</b> , <b>3749</b> or <b>Unknown</b> .
<b>Enable Provisioning Selected</b>	
<b>IPEI</b>	Default = 0 This field, if set to a value other than 0, sets the IPEI number of the handset that is able to subscribe to the DECT R4 system using this extension number. The IPEI for each DECT handset is unique.
<b>Use Handset Configuration</b>	Default = Off. If <b>Use Handset Configuration</b> is selected, the handset user is able to set the phone language and date/time format. If not selected, those settings will be driven by the system or user locale settings in the system configuration.

#### Related links

[Extension](#) on page 396

---

## SIP DECT Base Extension

Navigation: [Extension](#) | [SIP DECT Base](#)

This tab is displayed for SIP DECT extensions.

These settings are not mergeable. Changes to these settings will require a reboot of the system.

Field	Description
<b>DECT Line ID</b>	Use the drop-down list to select the SIP DECT Line from the system to the base station.

#### Related links

[Extension](#) on page 396

---

## User

### Additional configuration information

This section provides the User field descriptions.

For additional configuration information, see [Configure User Settings](#) on page 662.

## Related links

- [Configuration Mode Field Descriptions](#) on page 197
- [User](#) on page 414
- [Voicemail](#) on page 421
- [User | DND](#) on page 426
- [Short Codes](#) on page 427
- [Source Numbers](#) on page 428
- [Telephony](#) on page 435
- [User | Forwarding](#) on page 446
- [Dial In](#) on page 449
- [Voice Recording](#) on page 450
- [Button Programming](#) on page 452
- [User | Menu Programming](#) on page 453
- [Mobility](#) on page 454
- [Group Memberships](#) on page 458
- [Announcements](#) on page 458
- [SIP](#) on page 459
- [Personal Directory](#) on page 460
- [Web Self Administration](#) on page 462

---

## User

Navigation: [User](#) | [User](#)

### Additional configuration information

- For a summary of user management, including a description of centralized users, see [User Management Overview](#) on page 663.

This type of configuration record can be saved as a template and new records created from a template. See [Working with Templates](#) on page 600.

Users are the people who use the system or are Dial In users for data access. A system User may or may not have an Extension Number that physical exists - this is useful if users do not require a physical extension but wish to use system features, for example voicemail, forwarding, etc.

- The **NoUser** user is used to apply settings to extensions which have no associated user.
- The **Remote Manager** user is used as the default settings for dial in connections.

### Configuration Settings

These settings are mergeable. Changes to these settings do not require a reboot of the system.

— Except adding/removing centralized branch users which requires a system reboot.

The  symbol indicates that the setting can also be set by the user rights with which the user is associated. The user rights can be controlled by a time profile selected as the user's Working Hours Time Profile setting.



Field	Description
<b>Name</b>	<p>Range = Up to 15 characters.</p> <p>This is the user's account name used for RAS Dial In, Caller Display and voicemail mailbox. As the display on Caller Display telephones is normally only 16 digits long it is useful to keep the name short. Only alphanumeric characters and space are supported in this field. This field is case sensitive and must be unique.</p> <ul style="list-style-type: none"> <li>Names should not start with a space. Do not use punctuation characters such as #, ?, /, ^, &gt; and ,.</li> <li>Voicemail uses the name to create a matching user mailbox. Changing a user's name routes their voicemail calls to a new mailbox. Note however that Voicemail Pro is not case sensitive and will treat names such as "Steve Smith", "steve smith" and "STEVE SMITH" as being the same.</li> <li>Do not provision a user with the Name "admin". The user name "admin" is a reserved value on the one-X Portal Instant Message (IM) and Presence server. An IP Office "admin" user will not have IM and presence services.</li> <li>For Outbound Contact Express deployments, when an agent logs in to an extension, the user name associated with the extension is changed to the agent ID.</li> </ul>
<b>Password</b>	<p>Default = Blank. Range = Up to 31 alphanumeric characters.</p> <p>This password is used by user applications such as SoftConsole and TAPI. It is also used for user's with Dial In access.</p> <p>Note that this is not the user's voicemail mailbox password (see <b>User   Voicemail   Voicemail Code</b>) or their phone log in code (see <b>User   Telephony   Supervisor Settings   Login Code</b>).</p> <p>Password complexity rules are set through the General security settings. If complexity is not met, an error is displayed, however the configuration can still be saved (unless the system locale is set to France2).</p>
<b>Unique Identity</b>	<p>Default = Blank.</p> <p>An email address for the user. The address must be unique for each user. This email address is used for</p> <ul style="list-style-type: none"> <li>Avaya Cloud services.</li> <li>Avaya Communicator for Web client login.</li> <li>Gmail voicemail to email messages.</li> </ul> <p>This setting is separate (though it can be the same address) from the user's <b>Email Address</b> setting (see below) which is used for other email functions.</p>
<b>Login code</b>	<p>Default = Blank</p> <p>This code is used for logging in to extensions. It allows the user to hot desk between phones.</p>
<b>Confirm Login code</b>	<p>This code is to confirm the entered value in Login Code</p> <p>User entered code in Login Code and Confirm Login Code should match.</p>

*Table continues...*

Field	Description
<b>Audio Conference PIN</b>	<p>Default = Blank. Range = Up to 15 numeric characters.</p> <p>Use this field to configure PIN access for meet me conferences.</p> <p>An <b>L</b> in this field indicates that the unscheduled meet-me conference feature is disabled for this user.</p>
<b>Account Status</b>	<p>Default = Enabled.</p> <p>Use this setting to <b>Enable</b> or <b>Disable</b> a user account.</p> <p>You can also require a password reset by selecting Force New Password. A user can only set a new password through the one-X Portal user interface. This option should not be used if one-X Portal is not available.</p> <p>The <b>Account Status</b> can also be <b>Locked - Password Error</b> or <b>Locked - Temporary</b>. The user account enters these states automatically based on the password settings configured in the Security Settings General tab. If a user exceeds the <b>Password Reject Limit</b>, then the <b>Password Reject Action</b> is implemented. If the <b>Password Reject Action</b> is <b>Log and Disable Account</b>, then the account status is changed to <b>Locked - Password Error</b>. If the <b>Password Reject Action</b> is <b>Log and Temporary Disable</b>, then the account status is changed to <b>Locked - Temporary</b>.</p>
<b>Full Name</b>	<p>Default = Blank</p> <p>Use this field to enter the user's full name. The recommended format is &lt;first name&gt;&lt;space&gt;&lt;last name&gt; in order for this value to be used correctly by voicemail dial by name features. When set, the <b>Full Name</b> is used in place of the <b>Name</b> for display by phones and user applications. Names should not start with a space. Do not use punctuation characters such as @, #, ?, /, ^, &gt; and ,.</p>
<b>Extension</b>	<p>Range = 2 to 15 digits.</p> <p>In general all extensions should have the same number of digits. This setting can be left blank for users used just for dial in data connections.</p> <ul style="list-style-type: none"> <li>• Users associated with IP phones or who may log in as such devices should not be given extension numbers greater than 7 digits.</li> <li>• Centralized users' extension numbers can be up to 13 digits in length. Although IP Office supports extension numbers up to 15 digits, the 13-digit length is determined by the maximum extension number length allowed for provisioning Centralized users in Communication Manager.</li> </ul>
<b>Email Address</b>	<p>Default = Blank</p> <p>This address is used as the user's email address for a range of functions. Primarily it is used for voicemail-email functions if required. It is also used for any other emails that the system may send to the user.</p>

*Table continues...*



Field	Description
<b>Locale</b>	Default = Blank (Use system locale)  Configures the language used for voicemail prompts played to the user, assuming the language is available on the voicemail server. See <i>Avaya IP Office™ Platform Locale Settings</i> . On a digital extension it also controls the display language used for messages from the system. Note however that some phones have their own menu options for the selected language for the phone menus.
<b>Priority</b>	Default = 5. Range = 1 (Lowest) to 5 (Highest)  This setting is used by ARS.
<b>System Phone Rights</b>	Default = None Users set as a system phone user are able to access additional functions. The settings are: <ul style="list-style-type: none"> <li>• <b>None:</b> The user cannot access any system phone options.</li> <li>• <b>Level 1:</b> The user can access all system phone options supported on the type of phone they are using except system management and memory card commands.</li> <li>• <b>Level 2:</b> The user can access all system phone options supported on the type of phone they are using including system management and memory card commands. Due to the nature of the additional commands a login code should be set for the user to restrict access.</li> </ul>

## Profile Settings

Each user can be assigned to a particular profile. Each profile requires the system to have a matching license or subscription available for the user. The profile assigned to the user controls whether they can have a number of additional settings enabled. The tables below list those settings and profiles.

Option	IP500 V2 Standard Mode PLDS Licensed Systems				
	Basic User	Office Worker	Teleworker	Mobile Worker	Power User
<b>Enable Softphone</b>	—	—	Yes (On)	—	Yes (On)
<b>Enable one-X Portal Services</b>	—	Yes (On)	Yes (On)	—	Yes (On)
<b>Enable one-X Telecommuter</b>	—	—	Yes (On)	—	Yes (On)
<b>Enable Remote Worker</b>	Yes (Off)	Yes (Off)	Yes (On)	Yes (Off)	
<b>Enable Desktop/Tablet VoIP Client</b>	—	Yes (On)	Yes (On)	—	Yes (On)
<b>Enable Mobile VoIP Client</b>	—	—	—	—	Yes (On)
<b>Send Mobility Email</b>	—	—	—	Yes (Off)	Yes (Off)
<b>Web Collaboration</b>	—	Yes (Off)	Yes (Off)	—	Yes (Off)

Option	Server Edition PLDS Licensed Systems		
	Basic User	Office Worker	Power User
Enable Softphone	–	–	Yes (On)
Enable one-X Portal Services	–	Yes (On)	Yes (On)
Enable one-X Telecommuter	–	–	Yes (On)
Enable Remote Worker	Yes (Off)	Yes (Off)	Yes (On)
Enable Desktop/Tablet VoIP Client	Yes (Off)	Yes (On)	Yes (On)
Enable Mobile VoIP Client	–	–	Yes (On)
Send Mobility Email	–	–	Yes (Off)
Web Collaboration	–	Yes (Off)	Yes (Off)

Option	Subscription Mode Systems		
	Telephony User	Telephony Plus User	UC User
Enable Softphone	–	Yes (On)	Yes (On)
Enable one-X Portal Services	–	–	Yes (On)
Enable one-X Telecommuter	–	–	Yes (On)
Enable Remote Worker	Yes (Off)	Yes (Off)	Yes (On)
Enable Desktop/Tablet VoIP Client	–	Yes (Off)	Yes (On)
Enable Mobile VoIP Client	–	–	Yes (On)
Send Mobility Email	–	–	Yes (Off)
Web Collaboration	–	–	Yes (On)

Field	Description
Profile	<p>Default = Basic User.</p> <p>A user's profile controls whether they can be configured for a number of features. The different profiles available and the features accessible by each are shown in the tables above. The number of users that can be configured for each profile is controlled by the user licenses or subscription that the system has.</p> <ul style="list-style-type: none"> <li>• A <b>Non-licensed User</b> is allowed dial in access and paging and can be used as a Music on Hold or Analog paging port.</li> <li>• In non-subscription systems, a <b>Preferred Edition</b> system license is a pre-requisite for any user profile licenses. In a multi-site network, the <b>Preferred Edition</b> license of the central system is automatically shared with other systems in the network, enabling user profile licenses on those other systems. However, each system supporting a Voicemail Pro server still requires its own <b>Preferred Edition</b> license for Voicemail Pro operation.</li> <li>• To upgrade an <b>Office Worker</b> or <b>Mobile Worker</b> to a <b>Power User</b>, you must first set the user to <b>Basic User</b>.</li> </ul>

Table continues...

Field	Description
<b>Receptionist</b>	<p>Default = Off.</p> <p>This settings allows the user to use the SoftConsole application. This requires the configuration to have <b>Receptionist</b> licenses or subscriptions.</p> <ul style="list-style-type: none"> <li>• In PLDS licensed systems, a <b>Receptionist</b> license is only consumed when a configured user runs the SoftConsole application.</li> <li>• In subscription systems, a <b>Receptionist</b> subscription is consumed when a user is configured for SoftConsole use.</li> <li>• Up to 4 users can be licensed for IP500 V2 systems, 10 for Server Edition systems.</li> <li>• The use of SoftConsole is not supported for user's who then hot-desk to other systems in a the multi-site network.</li> </ul>
<b>Enable Softphone</b>	<p>Default = Controlled by the user profile, see the tables above.</p> <p>If selected, the user is able to use the IP Office Softphone application.</p>
<b>Enable one-X Portal Services</b>	<p>Default = Controlled by the user profile, see the tables above.</p> <p>If selected, the user is able to use the one-X Portal application, either directly or using one of its plug-in clients.</p>
<b>Enable one-X Telecommuter</b>	<p>Default = Controlled by the user profile, see the tables above.</p> <p>If selected, the user is able to use the telecommuter mode features of the one-X Portal application. Requires <b>Enable one-X Portal Services</b> to also be enabled.</p>
<b>Enable Remote Worker</b>	<p>Default = Off</p> <p>Indicates whether the user is allowed to use a remote H.323 or SIP extension.</p> <ul style="list-style-type: none"> <li>• SIP – This option is not required for SIP extension users phones if an Avaya Session Border Controller for Enterprise (ASBCE) is deployed in the network.</li> <li>• H323 – If the user's <b>Extension Number</b> matches the <b>Base Extension</b> setting of an IP extension, the <b>H.323 Remote Extn Enable</b> setting of that extension is automatically changed to match the user's <b>Enable Remote Worker</b> setting and vice versa.</li> <li>• On PLDS licensed systems, up to 4 <b>Basic User</b> users can be configured for <b>Enable Remote Worker</b>. Other user's will require licensing with another profile that supports the setting.</li> </ul>
<b>Enable Desktop/ Tablet VoIP client</b>	<p>Default = Controlled by the user profile, see the tables above.</p> <p>This option allows users to use Avaya Workplace Client on Windows or macOS operating systems.</p>
<b>Enable Mobile VoIP Client</b>	<p>Default = Controlled by the user profile, see the tables above.</p> <p>This option allows the users to use Avaya Workplace Client on Android and iOS operating systems.</p>

*Table continues...*

Field	Description
<b>Send Mobility Email</b>	<p>Default = Controlled by the user profile, see the tables above.</p> <p>When enabled, the user receives a welcome email with the following information:</p> <ul style="list-style-type: none"> <li>• A brief introduction of one-X Mobile Preferred for IP Office.</li> <li>• Instructions and links for installing and configuring the one-X Mobile Preferred for IP Office client.</li> </ul>
<b>Web Collaboration</b>	<p>Default = Controlled by the user profile, see the tables above.</p> <p>When enabled, allows the user to use the Web Collaboration application. For PLDS licensed systems, in addition to the user profile license, a <b>Web Collaboration</b> license is required for each user.</p> <p>Web Collaboration requires one-X Portal on a Linux-based server other than a Unified Communications Module (UCM).</p>
<b>Exclude From Directory</b>	<p>Default = Off</p> <p>When on, the user does not appear in the directory list shown by the user applications and on phones with a directory function. For users logging on as agents in an Outbound Contact Express deployment, <b>Exclude From Directory</b> must be <b>Off</b>.</p>
<b>Device Type</b>	<p>This field shows the type of phone at which the user is current logged in.</p> <ul style="list-style-type: none"> <li>• If the user is logged out but is associated with a <b>Base Extension</b>, the device type for that extension port is shown.</li> <li>• If the user has been logged out and is not associated with a <b>Base Extension</b>, the device type is listed as <b>Device Type Unknown</b>.</li> </ul>

### User Rights

Selected user settings can be overridden by those set within a set of User Rights. The same user rights can be applied to multiple users.

In addition, a time profile can be used to control when the user rights are applied to the user, and whether at other times, a different set of user rights are applied or the user's own settings.

Field	Description
<b>User Rights View</b>	This field affects Manager only. It allows you to switch between displaying the user settings as affected by their associated <b>Working Hours User Rights</b> or <b>Out of Hours User Rights</b> .
<b>Working Hours Time Profile</b>	<p>Default = &lt;None&gt; (Continuous).</p> <p>If set, the selected time profile defines when the user's <b>Working Hours User Rights</b> are applied. Outside the time profile, the user's <b>Out of Hours User Rights</b> are applied</p>
<b>Working Hours User Rights</b>	<p>Default = Blank (No rights restrictions).</p> <p>This field allows selection of user rights which may set and lock some user settings. If a <b>Working Hours Time Profile</b> has been selected, the <b>Working Hours User Rights</b> are only applied during the times defined by that time profile, otherwise they are applied at all times.</p>

*Table continues...*

Field	Description
<b>Out of Hours User Rights</b>	Default = Blank (No rights restrictions). This field allows selection of alternate user rights that are used outside the times defined by the user's Working Hours Time Profile.

### Related links

[User](#) on page 413

---

## Voicemail

Navigation: [User](#) | [Voicemail](#)

### Additional configuration information

The **Enable Gmail API** setting is used to configure Gmail Integration. For additional information, see [Configuring Gmail Integration](#) on page 668.

### Configuration settings

If a voicemail server application is being used on your system, each user has use of a voicemail mailbox. You can use this form to enable this facility and various user voicemail settings.

These settings are mergeable. Changes to these settings do not require a reboot of the system.



The  symbol indicates that the setting can also be set by the user rights with which the user is associated. The user rights can be controlled by a time profile selected as the user's Working Hours Time Profile setting.

Field	Description
<p><b>Voicemail Code</b></p>	<p>Default = Blank. Range = 0 (no code) to 31 digits.</p> <p>A code used by the voicemail server to validate access to this mailbox. If remote access is attempted to a mailbox that has no voicemail code set, the prompt "Remote access is not configured on this mailbox" is played.</p> <p>The mailbox access code can be set through IP Office Manager or through the mailbox telephone user interface (TUI). The minimum password length is:</p> <ul style="list-style-type: none"> <li>• Voicemail Pro (Manager): 0</li> <li>• Voicemail Pro (Intuity TUI): 2</li> <li>• Embedded Voicemail (Manager): 0</li> <li>• Embedded Voicemail (Intuity TUI): 0</li> </ul> <p>Codes set through the Voicemail Pro telephone user interface are restricted to valid sequences. For example, attempting to enter a code that matches the mailbox extension, repeat the same number (111111) or a sequence of numbers (123456) are not allowed. If these types of code are required they can be entered through Manager.</p> <p>Manager does not enforce any password requirements for the code if one is set through Manager.</p> <ul style="list-style-type: none"> <li>• <b>Embedded Voicemail:</b> For Embedded Voicemail running in IP Office mailbox mode, the voicemail code is used if set.</li> <li>• <b>IP Office mode:</b> The voicemail code is required when accessing the mailbox from a location that is not set as a trusted number in the user's Source Numbers list.</li> <li>• <b>Intuity Emulation mode:</b> By default the voicemail code is required for all mailbox access. The first time the mailbox is accessed the user will be prompted to change the password. Also if the voicemail code setting is left blank, the caller will be prompted to set a code when they next access the mailbox. The requirement to enter the voicemail code can be removed by adding a customized user or default collect call flow, refer to the Voicemail Pro manuals for full details.</li> <li>• <b>Trusted Source Access:</b> The voicemail code is required when accessing the mailbox from a location that is not set as a trusted number in the user's Source Numbers list.</li> <li>• <b>Call Flow Password Request:</b> Voicemail Pro call flows containing an action where the action's PIN code set to \$ will prompt the user for their voicemail code.</li> <li>• <b>Changing the Code:</b> All of the voicemail interfaces, except IMS and IMAP, provide options for the user to change the voicemail code themselves. In addition, Voicemail Pro running in Intuity emulation mode will request that the user sets a code when they first log in to their mailbox using the phone.</li> </ul>

*Table continues...*

Field	Description
<b>Voicemail On</b>	<p>Default = On.</p> <p>When on, the mailbox is used by the system to answer the user's unanswered calls or calls when the user's extension returns busy. Note that selecting off does not disable use of the user's mailbox. Messages can still be forward to their mailbox and recordings can be placed in it. The mailbox can also still be accessed to collect messages.</p> <p>When a caller is directed to voicemail to leave a message, the system indicates the target user or hunt group mailbox.</p> <ul style="list-style-type: none"> <li>• The mailbox of the originally targeted user or hunt group is used. This applies even if the call has been forwarded to another destination. It also includes scenarios where a hunt group call overflows or is in fallback to another group.</li> <li>• Voicemail Pro can be used to customize which mailbox is used separately from the mailbox indicated by the system.</li> </ul>
<b>Voicemail Help</b>	<p>Default = Off</p> <p>This option controls whether users retrieving messages are automatically given an additional prompt "For help at any time press 8." If switched off, users can still press 8 for help. For voicemail systems running in Intuity emulation mode, this option has no effect. On those systems the default access greeting always includes the prompt "For help at any time, press *4" (*H in the US locale).</p>
<b>Voicemail Ringback</b>	<p>Default = Off </p> <p>When enabled and a new message has been received, the voicemail server calls the user's extension to attempt to deliver the message each time the telephone is put down. Voicemail will not ring the extension more than once every 30 seconds.</p>
<b>Voicemail Email Reading</b>	<p>Default = Off</p> <p>This option can be enabled for users whose Profile is set to <b>Mobile Worker</b> or <b>Power User</b>. If enabled, when you log into you voicemail box, it will detect your email messages and read them to you. This email text to speech feature is set-up through Voicemail Pro. This option is not currently supported with Linux based Voicemail Pro.</p>
<b>UMS Web Services</b>	<p>Default = On</p> <p>When selected, the user can use any of the Voicemail Pro UMS services to access their voicemail messages (IMAP email client, web browser or Exchange 2007 mailbox). Note that the user must have a voicemail code set in order to use the UMS services.</p> <ul style="list-style-type: none"> <li>• For subscription systems, this setting is only supported for <b>UC User</b>.</li> <li>• For PLDS licensed systems, this setting is only supported for <b>Teleworker, Office Worker</b> or <b>Power User</b> users.</li> </ul>

*Table continues...*

Field	Description
<p><b>Enable Gmail API</b></p>	<p>Default = Off.</p> <p>This setting is only supported on Server Edition systems and requires the user to have <b>UMS Web Services</b> enabled.</p> <p> <b>Important:</b></p> <ul style="list-style-type: none"> <li>• Due to changes in the Gmail API, support for this feature has been withdrawn. Support will be re-enabled in a future release.</li> </ul> <p>When enabled:</p> <ul style="list-style-type: none"> <li>• The <b>Voicemail Email</b> setting is disabled.</li> <li>• The <b>Voicemail Email Mode</b> options (<b>Off, Copy, Forward, Alert</b>) are available.</li> </ul> <p>This feature uses the Gmail address defined in the setting <b>User   User   Unique Identity</b>.</p>
<p><b>Voicemail Email</b></p>	<p>Default = Blank (No voicemail email features)</p> <p>This field is used to set the user or group email address used by the voicemail server for voicemail email operation. When an address is entered, the additional Voicemail Email control below are selectable to configure the type of voicemail email service that should be provided.</p> <p>Use of voicemail email requires the Voicemail Pro server to have been configured to use either a local MAPI email client or an SMTP email server account. For Embedded Voicemail, voicemail email is supported and uses the system's SMTP settings.</p> <p>The use of voicemail email for the sending (automatic or manual) of email messages with wav files attached should be considered with care. A one-minute message creates a 1MB .wav file. Many email systems impose limits on emails and email attachment sizes. For example the default limit on an Exchange server is 5MB.</p> <p> <b>Note:</b></p> <p>Unicode characters are not supported.</p>

*Table continues...*



Field	Description
<b>Voicemail Email Mode</b>	<p>Default = Off</p> <p>This option is selectable when for users and groups when either:</p> <ul style="list-style-type: none"> <li>• A <b>Voicemail Email</b> email address is set.</li> <li>• The <b>Enable Gmail API</b> is set to <b>On</b>.</li> </ul> <p>These settings control the mode of automatic voicemail email operation provided by the voicemail server whenever the voicemail mailbox receives a new voicemail message. Users can change their voicemail email mode using visual voice. The ability to change the voicemail email mode can also be provided by Voicemail Pro in a call flow using a Play Configuration Menu action or a Generic action.</p> <p>If the voicemail server is set to IP Office mode</p> <ul style="list-style-type: none"> <li>• Users can change their voicemail email mode through the telephone prompts.</li> <li>• users can manually forward a message to email.</li> </ul> <p>The options are:</p> <ul style="list-style-type: none"> <li>• <b>Off</b> If off, none of the options below are used for automatic voicemail email. Users can also select this mode by dialing *03 from their extension.</li> <li>• <b>Copy</b> If this mode is selected, each time a new voicemail message is received in the voicemail mailbox, a copy of the message is attached to an email and sent to the email address. There is no mailbox synchronization between the email and voicemail mailboxes. For example reading and deletion of the email message does not affect the message in the voicemail mailbox or the message waiting indication provided for that new message.</li> <li>• <b>Forward</b> If this mode is selected, each time a new voicemail message is received in the voicemail mailbox, that message is attached to an email and sent to the email address. No copy of the voicemail message is retained in the voicemail mailbox and there is no message waiting indication. As with Copy, there is no mailbox synchronization between the email and voicemail mailboxes. Users can also select this mode by dialing *01 from their extension.</li> </ul> <p>Note that until email forwarding is completed, the message is present in the voicemail server mailbox and so may trigger features such as message waiting indication.</p> <ul style="list-style-type: none"> <li>• <b>UMS Exchange 2007</b> With Voicemail Pro, the system supports voicemail email to an Exchange 2007 server email account. For users and groups also enabled for UMS Web Services this significantly changes their mailbox operation. The Exchange Server inbox is used as their voicemail message store and features such as message waiting indication are set by new messages in that location rather than the voicemail mailbox on the voicemail server. Telephone access to voicemail messages, including Visual Voice access, is redirected to the Exchange 2007 mailbox.</li> <li>• <b>Alert</b> If this mode is selected, each time a new voicemail message is received in the voicemail mailbox, a simple email message is sent to the email address. This is an email message announcing details of the voicemail message but with no copy of the voicemail message attached. Users can also select this mode by dialing *02 from their extension.</li> </ul>

*Table continues...*

Field	Description
<b>DTMF Breakout</b> 	<p>When a caller is directed to voicemail to leave a message, they can be given the option to be transferred to a different extension. The greeting message needs to be recorded telling the caller the options available. The extension numbers that they can be transferred to are entered in the fields below. System default values can be set for these numbers and are used unless a different number is set within these user settings. The values can be set using User Rights.</p> <p>The Park &amp; Page feature is supported when the system voicemail type is configured as <b>Embedded Voicemail</b> or <b>Voicemail Pro</b>. Park &amp; Page is also supported on systems where Avaya Aura Messaging, Modular Messaging over SIP, or CallPilot (for Enterprise Branch with CS 1000 deployments) is configured as the central voice mail system and the local Embedded Voicemail or Voicemail Pro provides auto attendant operation. The Park &amp; Page feature allows a call to be parked while a page is made to a hunt group or extension. This feature can be configured for Breakout DTMF 0, Breakout DTMF 2, or Breakout DTMF 3.</p>
<b>Reception/ Breakout (DTMF 0)</b>	<p>The number to which a caller is transferred if they press 0 while listening to the mailbox greeting rather than leaving a message (*0 on Embedded Voicemail in IP Office mode).</p> <p>For voicemail systems set to Intuity emulation mode, the mailbox owner can also access this option when collecting their messages by dialing *0.</p> <p>If the mailbox has been reached through a Voicemail Pro call flow containing a <b>Leave Mail</b> action, the option provided when 0 is pressed are:</p> <ul style="list-style-type: none"> <li>• For IP Office mode, the call follows the <b>Leave Mail</b> action's <b>Failure</b> or <b>Success</b> results connections depending on whether the caller pressed 0 before or after the record tone.</li> <li>• For Intuity mode, pressing 0 always follows the <b>Reception/Breakout (DTMF 0)</b> setting.</li> </ul> <p>When Park &amp; Page is selected for a DTFM breakout, the following drop-down boxes appear:</p> <ul style="list-style-type: none"> <li>• <b>Paging Number</b> – displays a list of hunt groups and users (extensions). Select a hunt group or extension to configure this option.</li> <li>• <b>Retries</b> – the range is 0 to 5. The default setting is 0.</li> <li>• <b>Retry Timeout</b> – provided in the format M:SS (minute:seconds). The range can be set in 15-second increments. The minimum setting is 15 seconds and the maximum setting is 5 minutes. The default setting is 15 seconds</li> </ul>
<b>Breakout (DTMF 2)</b>	The number to which a caller is transferred if they press 2 while listening to the mailbox greeting rather than leaving a message (*2 on Embedded Voicemail in IP Office mode).
<b>Breakout (DTMF 3)</b>	The number to which a caller is transferred if they press 3 while listening to the mailbox greeting rather than leaving a message (*3 on Embedded Voicemail in IP Office mode).

**Related links**

[User](#) on page 413

---

## User | DND

Navigation: **User | DND**

Do not disturb prevents the user from receiving hunt group and page calls. Direct callers hear busy tone or are diverted to voicemail if available. It overrides any call forwarding, follow me and call coverage settings. A set of exception numbers can be added to list numbers from which the user still wants to be able to receive calls when they have do not disturb in use.

The  symbol indicates that the setting can also be set by the user rights with which the user is associated. The user rights can be controlled by a time profile selected as the user's Working Hours Time Profile setting.

These settings are mergeable. Changes to these settings do not require a reboot of the system.

Field	Description
<b>Do Not Disturb</b>	Default = Off  When checked the user's extension is considered busy, except for calls coming from sources listed in their Do Not Disturb Exception List. When a user has do not disturb in use, their normal extension will give alternate dialtone when off hook. Users with DND on are indicated as 'busy' on any BLF indicators set to that user.
<b>Do Not Disturb Exception List</b>	Default = Blank This is the list of telephone numbers that are still allowed through when Do Not Disturb is set. For example this could be an assistant or an expected phone call. Internal extension numbers or external telephone numbers can be entered. If you wish to add a range of numbers, you can either enter each number separately or make use of the wildcards "N" and "X" in the number. For example, to allow all numbers from 7325551000 to 7325551099, the DND Exception number can be entered as either 73255510XX or 73255510N. Note that this list is only applied to direct calls to the user. Calls to a hunt group of which the user is a member do not use the Do Not Disturb Exceptions list.

### Related links

[User](#) on page 413

---

## Short Codes

Navigation: [User](#) | [Short Codes](#)

### Additional configuration information

For additional configuration information on short codes, see [Short Code Overview](#) on page 806.

### Configuration settings

Short codes entered in this list can only be dialed by the user. They will override any matching user rights or system short code.

User and User Rights short codes are only applied to numbers dialed by that user. For example they are not applied to calls forwarded via the user.

 **Warning:**

User dialing of emergency numbers must not be blocked by the addition of short codes. If short codes are added, the users ability to dial emergency numbers must be tested and maintained.

The  symbol indicates that the setting can also be set by the user rights with which the user is associated. The user rights can be controlled by a time profile selected as the user's Working Hours Time Profile setting.

These settings are mergeable. Changes to these settings do not require a reboot of the system.

Short codes can be added and edited using the **Add**, **Remove** and **Edit** buttons. Alternatively you can right-click on the list of existing short code to add and edit short codes.

**\*FWD:**

Short codes of this form are inserted by the system. They are used in conjunction with the **User | Forwarding** settings to remember previously used forwarding numbers. They can be accessed on that tab by using the drop-down selector on the forwarding fields.

**\*DCP:**

Short codes of this form are often inserted by the system. They are used by some phone types to contain settings relating to functions such as ring volume and auto answer. Deleting such short codes will cause related phone settings to return to their defaults.

**\*DCP/Dial/8xxxxxxx, 0, 1, 1, 0/0:**

For system's with TCM phone ports, when a phone is first connected to the port, the button programming of the associated user is overwritten with the default button programming appropriate for the phone model. Adding the above short code prevents that behavior if not required, for example if a pre-built configuration including user button programming is added to the system before the connection of phones.

**Related links**

[User](#) on page 413

---

## Source Numbers

Navigation: **User | Source Numbers**

This page is used to enter values that have special usages. These are entered using the **Add**, **Edit** and **Remove** buttons.

These settings are mergeable. Changes to these settings do not require a reboot of the system.

### User Source Numbers

The following types of records can be added to a user's source numbers:

Value	Description
<b>AT&lt;string&gt;</b>	Strings beginning with AT can be used with a user called <b>DTEDefault</b> to configure the default settings of the control unit's DTE port.
<b>BST_MESSAGE_FOR_YOU</b>	If set, then the BST phone user sees the top line <b>Message for you</b> or <b>Messages for you</b> , indicating that voicemail messages are present. This source number can be used as a NoUser source number to enable the feature for all users.
<b>BST_NO_MESSAGE_FOR_YOU</b>	If the source number above has been used as a NoUser source number to enable the feature for all BST users, this individual user source number can be used to disable the feature for selected users. If set, the user does not see a message indication when the NoUser setting <b>BST_MESSAGE_FOR_YOU</b> is set. The user's phone presents the idle date/time in the normal fashion.
<b>Enable_OTT</b>	Enable one touch transfer operation for the user.
<b>H&lt;Group_Name&gt;</b>	<p>Allows the user to receive message waiting indication of new group messages. Enter H followed by the group name, for example <b>HMain</b>. The group is added to the user's Visual Voice menu.</p> <p>On suitable display extensions, the hunt group name and number of new messages is displayed. Refer to the appropriate telephone user guide.</p> <p>If the user is not a member of the group, a voicemail code must be set for the group's mailbox. See the setting <b>Group   Voicemail   Voicemail Code</b> .</p>
<b>P&lt;Telephone Number&gt;</b>	This record sets the destination for callback (outbound alert) calls from voicemail. Enter P followed by the telephone number including any necessary external dialing prefix, for example P917325559876. This facility is only available when using Voicemail Pro through which a default Callback or a user specific Callback start point has been configured. Refer to the Voicemail Pro documentation. This feature is separate from voicemail ringback and Voicemail Pro outcalling.
<b>R&lt;Caller's ICLID&gt;</b>	To allow Dial In/RAS call access only from a specified number prefix the number with a "R", for example <b>R7325551234</b> .
<b>U&lt;User_Name or Extension#&gt;</b>	<p>Allows the user to receive message waiting indication of new messages. Enter U followed by the user name or extension number, for example <b>U201</b>. The specified user is added to the user's Visual Voice menu.</p> <p>On suitable display extensions, the user name and number of new messages is displayed. Refer to the appropriate telephone user guide.</p> <p>If the user is not a trusted source and a Voicemail Code exists, the user must enter the Voicemail Code corresponding to the monitored mailbox.</p>
<b>V&lt;Caller's ICLID&gt;</b>	<p>Strings prefixed with a <b>V</b> indicate numbers from which access to the users mailbox is allowed without requiring entry of the mailbox's voicemail code. This is referred to as "trusted source".</p> <p>For Voicemail Pro running in Intuity mode, trusted source is used for calls from programmable buttons set to Voicemail Collect and Visual Voice. Other controls are prompted for the mailbox number and then password.</p>

## NoUser Source Numbers

The following source numbers can also be used on the **Source Numbers** tab of the NoUser user. These affect all users on the system.

**\* Note:**

Changes to these source numbers require a system reboot to become effective.

Value	Description
<b>ATM4U_PCS7_RINGDETECT</b>	For some cellular or mobile interfaces connected to a IP500 ATM4U card, the card may not detect the ring signal. For PCS4 and higher card this NoUser source number can be used activate alternate ring detection. Refer to IP Office Technical Tip 204.
<b>ALLOW_5410_UPGRADES</b>	Previously the only control over the upgrading of 5410 phones was controlled by the use of the turn_on.bat and turn_off.bat batch files installed with the Manager application. Now in addition, this option must be present for 5410 phones to update their firmware. Refer to the IP Office Installation manual for full details.
<b>B_DISABLE_SIP_IPADDR</b>	Disables the blacklisting of SIP device registration based on the device IP address. Refer to the IP Office Security Guidelines document for more details.
<b>BST_MESSAGE_FOR_YOU</b>	If set, all BST phones display the top line <b>Message for you</b> or <b>Messages for you</b> , indicating that voicemail messages are present.
<b>DECT_REVERSE_RING</b>	By default, when this parameter is not set, calls on DECT phones associated with a CTI application will ring as a Priority call. When this parameter is set, DECT phones ring as a normal, external or internal, call.
<b>DISTINCT_HOLD_RINGBACK</b>	Used to display a specific message about the call type for calls returning after timing out from being parked or held. If set, such calls display <b>Return Call - Held</b> or <b>Return Call - Parked</b> rather than connected party name or line name.
<b>Enable_OTT</b>	Enable one touch transfer for all users.
<b>FORCE_HANDSFREE_TRANSFER</b>	If set, when using the handsfree announced transfer process, both the transfer enquiry and transfer completion calls are auto-answered. Without this setting only the transfer enquiry call is auto-answered.
<b>HIDE_CALL_STATE</b>	Used to hide the call status information, for example Dial, Conn, etc, on DS phones. Used in conjunction with the LONGER_NAMES option. Not supported for 1600 and 9600 Series phones.
<b>LONGER_NAMES</b>	Used to increase the length of names sent for display on older DS phones, i.e. 2400, 4400 and 5400 Series.

*Table continues...*

Value	Description
<b>MEDIA_NAT_DM_INTERNAL=X</b>	<p>Used in conjunction with the setting <b>System   VoIP   Allow Direct Media Within NAT Location</b></p> <p>When <b>Allow Direct Media Within NAT Location</b> is set to on, The default behavior is to allow direct media between all types of devices (H323 and SIP remote workers and IP Office Lines behind a NAT). In the case of routers that have H323 or SIP ALG, it can be desirable to allow direct media only between certain categories of devices. In this case, set this NoUser user source number where X is a hex number defined as a combination of the following flags:</p> <ul style="list-style-type: none"> <li>• 0x01 (includes H323 phones)</li> <li>• 0x02 (includes SIP phones)</li> <li>• 0x04 (includes IP Office Lines)</li> </ul> <p>For example, if the router has SIP ALG that can't be disabled, you might want to disable direct media for SIP devices. To configure, set <b>MEDIA_NAT_DM_INTERNAL=5</b> to include only H323 phones and IP Office Lines.</p>
<b>NI2_CALLED_PARTY_PLAN=X</b>	<p>X = UNKNOWN or ISDN</p> <p>Forces the NI2 Called Party Numbering plan for ETSI PRI trunks.</p>
<b>NI2_CALLED_PARTY_TYPE=X</b>	<p>X = UNKNOWN, INTERNATIONAL, NATIONAL or SUBSCRIBER</p> <p>Forces the NI2 Called Party Numbering type for ETSI PRI trunks.</p>
<b>NI2_CALLING_PARTY_PLAN=X</b>	<p>X = UNKNOWN or ISDN</p> <p>Forces the NI2 Calling Party Numbering plan for ETSI PRI trunks.</p>
<b>NI2_CALLING_PARTY_TYPE=X</b>	<p>X = UNKNOWN, INTERNATIONAL, NATIONAL or SUBSCRIBER</p> <p>Forces the NI2 Calling Party Numbering type for ETSI PRI trunks.</p>
<b>NO_DIALLED_REF_EXTERNAL</b>	<p>On outgoing external calls made using short codes to dial the full number, only the short code dialed is displayed on the dialing user's phone and any directory matching is based on that number dialed. On systems with this source number added to the configuration, after dialing a short code the full number dialed by that short code is shown and directory matching is based on that full number.</p>
<b>onex_i1=X</b>	<p>Sets the IP address of the one-X server that can be accessed by clients registered on the LAN1 interface.</p>
<b>onex_i2=X</b>	<p>Sets the IP address of the one-X server that can be accessed by clients registered on the LAN2 interface.</p>
<b>onex_port_i1=X</b>	<p>Sets the port of the one-X server that can be accessed by clients registered on the LAN1 interface.</p>
<b>onex_port_i2=X</b>	<p>Sets the port of the one-X server that can be accessed by clients registered on the LAN2 interface.</p>
<b>onex_port_r1=X</b>	<p>Sets the port of the one-X server that can be accessed by remote clients registered on the LAN1 interface.</p>
<b>onex_port_r2=X</b>	<p>Sets the port of the one-X server that can be accessed by remote clients registered on the LAN2 interface.</p>

*Table continues...*

Value	Description
<b>onex_r1=X</b>	Sets the IP address of the one-X server that can be accessed by remote clients registered on the LAN1 interface.
<b>onex_r2=X</b>	Sets the IP address of the one-X server that can be accessed by remote clients registered on the LAN2 interface.
<b>PRESERVED_CONN_DURATION=X</b>	X = time in minutes. Range = 1 to 120. When the setting <b>System   Telephony   Telephony   Media Connection Preservation</b> is enabled, preserved calls have a maximum duration of 120 minutes. After that time, they are hung up. Use this setting to change the maximum duration value.
<b>PRESERVED_NO_MEDIA_DURATION=X</b>	X = time in minutes. Range = 1 to 120. When the setting <b>System   Telephony   Telephony   Media Connection Preservation</b> is enabled, preserved calls have a maximum duration of 120 minutes. If monitoring RTP or RTCP and no speech is detected, calls are hung up after 10 minutes. Use this setting to change the default value of 10 minutes.
<b>ProgressEndsOverlapSend</b>	See <b>Line   VoIP</b> .
<b>REPEATING_BEEP_ON_LISTEN</b>	By default, if you set Beep on Listen and invoke Call Listen you'll hear an entry tone (3 beeps). When this parameter is set, you hear a beep every 10 seconds when you invoke Call Listen.
<b>RTCP_COLLECTOR_IP=X</b>	X = IP address of the IP Office system as configured in the Prognosis server.
<b>RW_SBC_REG=&lt;SBC-B1-public-SIP-IPaddr&gt;</b>	Used for Remote Worker Session Boarder Controller Enterprise (SBCE) configuration on 11xx, 12xx, and E129 phones. The IP address is used as a S1/S2 for 11xx and 12xx and for outbound-proxy-server for E129 sets.
<b>RW_SBC_PROV=&lt;SBC-B1-private-HTTP/S-IPaddr&gt;</b>	Used for Remote Worker Session Boarder Controller Enterprise (SBCE) configuration on 11xx, 12xx, and E129 phones. The IP address is used to determine whether a 11xx, 12xx, or E129 set is registered as an IP Office SBCE Remote Worker.
<b>RW_SBC_TLS=&lt;SBC-public-TLS-port&gt;</b>	Used for Remote Worker Session Boarder Controller Enterprise (SBCE) configuration on 11xx, 12xx, and E129 phones. The port is used as a S1/S2 TLS port for 11xx and 12xx phones and as outbound-proxy-server TLS port for E129 phones.
<b>RW_SBC_TCP=&lt;SBC-public-TCP-port&gt;</b>	Used for Remote Worker Session Boarder Controller Enterprise (SBCE) configuration on 11xx, 12xx, and E129 phones. The port is used as a S1/S2 TCP port for 11xx and 12xx phones and as outbound-proxy-server TCP port for E129 phones.
<b>RW_SBC_UDP=&lt;SBC-public-UDP-port&gt;</b>	Used for Remote Worker Session Boarder Controller Enterprise (SBCE) configuration on 11xx, 12xx, and E129 phones. The port is used as a S1/S2 UDP port for 11xx and 12xx phones and as outbound-proxy-server UDP port for E129 phones.

*Table continues...*



Value	Description
<b>SET_46xx_PROCPSWD=X</b>	X= New password When set, the new password is indicated to phones through the auto-generated settings file.
<b>SET_96xx_SIG=X</b>	When set, inserts the line "SET SIG X into the auto-generated settings files.
<b>SET_HEADSYS_1</b>	If set, alters the operation of the headset button on 9608, 9611, 9621, and 9641 phones via the auto-generated settings file. Normally the headset goes off-hook when the far end disconnects. When this option is set, the headset remains on-hook when the far end disconnects.
<b>SIP_E129_PREFER_UDP</b>	When set, the auto-generated E129 configuration file is altered to set the transport method as UDP regardless of whether TCP or TLS are selected on the LAN1/LAN2 VoIP configuration settings.
<b>SIP_ENABLE_HOT_DESK</b>	For IP Office Release 10.1, by default the use of hot-desking on J129 and H175 phones is blocked. This source numbers overrides that behavior.
<b>SIP_EXTN_CALL_Q_TIMEOUT=X</b>	X = Number of minutes (0 (no limit) to 255). Sets the unanswered call duration after which unanswered SIP calls are automatically disconnected. If not set, the normal default is 5 minutes.
<b>SIP_OPTIONS_PERIOD=X</b>	X = time in minutes. The system sends SIP options messages periodically to determine if the SIP connection is active. The rate at which the messages are sent is determined by the combination of the <b>Binding Refresh Time</b> (in seconds) set on the Network Topology tab and the <b>SIP_OPTIONS_PERIOD</b> parameter (in minutes). The frequency of sent messages is determined as follows:  If no <b>SIP_OPTIONS_PERIOD</b> parameter is defined and the <b>Binding Refresh Time</b> is <b>0</b> , then the default value of 300 seconds is used.  To establish a period less than 300 seconds, do not define a <b>SIP_OPTIONS_PERIOD</b> parameter and set the <b>Binding Refresh Time</b> to a value less than 300 seconds. The OPTIONS message period will be equal to the <b>Binding Refresh Time</b> .  To establish a period greater than 300 seconds, a <b>SIP_OPTIONS_PERIOD</b> parameter must be defined. The <b>Binding Refresh Time</b> must be set to a value greater than 300 seconds. The OPTIONS message period will be the smaller of the <b>Binding Refresh Time</b> and the <b>SIP_OPTIONS_PERIOD</b> .
<b>SOFTPHONE_RTP_MAX=X</b>	X = Maximum port in the range 1024 to 65534. The maximum usable port indicated to the IP Office Video Softphone when <b>SOFTPHONE_RTP_RANGE_ENABLE</b> and <b>SOFTPHONE_RTP_MIN</b> are set.
<b>SOFTPHONE_RTP_MIN=X</b>	X = Minimum port in the range 1024 to 65534. The minimum usable port indicated to the IP Office Video Softphone when <b>SOFTPHONE_RTP_RANGE_ENABLE</b> and <b>SOFTPHONE_RTP_MAX</b> are set.
<b>SOFTPHONE_RTP_RANGE_ENABLE</b>	When set, the usable ports indicated to the IP Office Video Softphone are set via the <b>SOFTPHONE_RTP_MIN</b> and <b>SOFTPHONE_RTP_MAX</b> values.
<b>SUPPRESS_ALARM=1</b>	When set, suppresses the NoCallerID alarm otherwise shown in SysMonitor, SNMP traps, email notifications, SysLog or System Status.

*Table continues...*

Value	Description
<b>TUI:NAME_SEARCH_MODE=1</b>	Used to configure system wide telephony user interface (TUI) options for 1400, 1600, 9500, 9600 and J100 Series phones (except the J129).  The default directory search matching behavior is to simultaneously match against first and last name characters. This source number sets the system to match from the start of the name only.
<b>VM_TRUNCATE_TIME=X</b>	X= time in seconds. Range = 0 to 7.  On analog trunks, call disconnection can occur though busy tone detection. When such calls go to voicemail to be recorded or leave a message, when the call ends the system indicates to the voicemail server how much to remove from the end of the recording in order to remove the busy tone segment. This amount varies by system locale, the defaults being listed below. For some systems it may be necessary to override the default if analog call recordings are being clipped or include busy tone. That can be done by adding a <b>VM_TRUNCATE_TIME=</b> setting with the required value in the range 0 to 7 seconds.  <ul style="list-style-type: none"> <li>• <b>New Zealand, Australia, China, Saudi Arabia and Custom:</b> 5 seconds.</li> <li>• <b>Korea:</b> 3 seconds.</li> <li>• <b>Italy, Mexico, Chile, Colombia and Brazil:</b> 2 seconds.</li> <li>• <b>Argentina, United States, Canada and Turkey:</b> 0 seconds.</li> <li>• <b>All other locales:</b> 7 seconds.</li> </ul>
<b>VMAIL_WAIT_DURATION=X</b>	The number of milliseconds to wait before cutting through the audio to Voicemail. Some delay is required to allow for codec negotiation.
<b>VMPRO_OOB_DTMF_OFF</b>	When set, disabled the sending of out-of-band digits to the Voicemail Pro voicemail server.
<b>xmpp_port_l1=X</b>	X = The port of the XMPP server that can be accessed by clients registered on the LAN1 interface.
<b>xmpp_port_l2=X</b>	X = The port of the XMPP server that can be accessed by clients registered on the LAN2 interface.
<b>xmpp_port_r1=X</b>	X = The port of the XMPP server that can be accessed by remote clients registered on the LAN1 interface.
<b>xmpp_port_r2=X</b>	X = The port of the XMPP server that can be accessed by remote clients registered on the LAN2 interface.

*Table continues...*

Value	Description
<b>EQNX_CONTACT_MATCHING_MIN_DIGITS= X</b>	<p>This NUSN is used to define the minimum digits for contact matching for the countries where national dial plan phone numbers are less than 10 digits, such as Bahrain.</p> <p>X= The minimum digits required for Avaya Workplace Client contact matching. Currently it requires 10 (or more digits) or must be an exact match.</p> <p>The IP Office server sets the minimum length to match the phone number contact.</p> <ul style="list-style-type: none"> <li>• When NUSN is set and the system locale is Bahrain, then the default value of minimum length for contact matching is the value set by NUSN.</li> <li>• When NUSN is not set and the system locale is Bahrain, then the default value of minimum length for contact matching is 8.</li> </ul> <p> <b>Note:</b> This NUSN is specific to Avaya Workplace Client.</p>

### Related links

[User](#) on page 413

## Telephony

Navigation: **User | Telephony**

This form allows you to set telephony related features for the user. These override any matching setting in the **System | Telephony** tab. The settings are grouped into a number of sub-tabs.

### Related links

[User](#) on page 413

[Call Settings](#) on page 435

[Supervisor Settings](#) on page 438

[Multi-line Options](#) on page 442

[Call Log](#) on page 444

[TUI](#) on page 445

## Call Settings

Navigation: **User | Telephony | Call Settings**

### Additional configuration information

For additional information on ring tones, see [Ring Tones](#) on page 619.

### Configuration settings

The  symbol indicates that the setting can also be set by the user rights with which the user is associated. The user rights can be controlled by a time profile selected as the user's Working Hours Time Profile setting.

These settings are mergeable. Changes to these settings do not require a reboot of the system.





Field	Description
<b>Outside Call Sequence</b>	<p>Default = Default Ring (Use system setting)</p> <p>Applies only to analog phones. Sets the ring pattern used for external calls to the user. The distinctive ring patterns used for other phones are fixed. Note that changing the pattern for users associated with fax and modem device extensions may cause those devices to not recognize and answer calls.</p>
<b>Inside Call Sequence</b>	<p>Default = Default Ring (Use system setting)</p> <p>Applies only to analog phones. Sets the ring pattern used for internal calls to the user. The distinctive ring patterns used for other phones are fixed.</p>
<b>Ring Back Sequence</b>	<p>Default = Default Ring (Use system setting)</p> <p>Applies only to analog phones. Sets the ring pattern used for ringback calls to the user. The distinctive ring patterns used for other phones are fixed.</p>
<b>No Answer Time</b>	<p>Default = Blank (Use system setting). Range = 6 to 99999 seconds. </p> <p>Sets how long a call rings the user before following forwarded on no answer if set or going to voicemail. Leave blank to use the system default setting.</p>
<b>Wrap-up Time (secs)</b>	<p>Default = 2 seconds, Range 0 to 99999 seconds.  Specifies the amount of time after ending one call during which the user is treated as still being busy. During this time:</p> <ul style="list-style-type: none"> <li>• Other phones or applications monitoring the user's status will indicate the user as still being busy (on a call).</li> <li>• Hunt group calls will not be presented to the user.</li> <li>• If the user is using a single line set, direct calls also receive busy treatment. If the user is using a multi-line set (multiple call appearances), direct calls to them will ring as normal.</li> <li>• It is recommended that this option is not set to less than the default of 2 seconds. 0 is used to allow immediate ringing.</li> <li>• For users set as a CCR Agent, use the setting <b>User   Telephony   Supervisor Settings   After Call Work Time</b>.</li> </ul>
<b>Transfer Return Time (secs)</b>	<p>Default = Blank (Off), Range 1 to 99999 seconds. </p> <p>Sets the delay after which any call transferred by the user, which remains unanswered, should return to the user. A return call will continue ringing and does not follow any forwards or go to voicemail.</p> <p>Transfer return will occur if the user has an available call appearance button.</p> <p>Transfer return is not applied if the transfer is to a hunt group that has queuing enabled.</p>
<b>Call Cost Mark-Up</b>	<p>Default = 100.</p> <p>This setting is used for ISDN advice of charge (AOC). The markup is applied to the cost calculations based on the number of units and the line base cost per charging unit. The field is in units of 1/100th, for example an entry of 100 is a markup factor of 1. This value is included in the system SMDR output.</p>

Table continues...

Field	Description
<b>Advertize Callee State To Internal Callers</b>	<p>Default = System Default (Off).</p> <p>The options are:</p> <ul style="list-style-type: none"> <li>• <b>System Default (Off)</b>. The system setting is <b>System   Telephony   Telephony   Advertize Callee State To Internal Callers</b>.</li> <li>• <b>On</b></li> <li>• <b>Off</b></li> </ul> <p>When enabled, for internal calls, additional status information is communicated to the calling party.</p> <p>Not supported for SIP endpoints except the J100 Series (excluding the J129).</p> <ul style="list-style-type: none"> <li>• When calling another internal phone and the called phone is set to Do Not Disturb or on another call, the calling phone displays “Do Not Disturb” or “On Another Call” rather than “Number Busy”.</li> <li>• On 9500 Series, 9600 Series and J100 Series phones, if a line appearance is programmed on a button on phone A and that line is in use on phone B, then phone A displays the name of the current user of the line along with the line number.</li> <li>• If a line appearance on a phone is in use elsewhere in the system and another extension unsuccessfully attempts to seize that line, the phone displays “In Use:&lt;name&gt;” where &lt;name&gt; is the name of the user currently using the line.</li> </ul>
<b>Call Waiting On</b>	<p>Default = Off </p> <p>For users on phones without appearance buttons, if the user is on a call and a second call arrives for them, an audio tone can be given in the speech path to indicate a waiting call (the call waiting tone varies according to locale). The waiting caller hears ringing rather than receiving busy. There can only be one waiting call, any further calls receive normal busy treatment. If the call waiting is not answered within the no answer time, it follows forward on no answer or goes to voicemail as appropriate. User call waiting is not used for users on phones with multiple call appearance buttons.</p>
<b>Answer Call Waiting on Hold</b>	<p>Default = On</p> <p>Applies to analog and IP DECT extension users only. If the user has a call waiting and places their current call on hold, the waiting call is automatically connected.</p>
<b>Busy on Held</b>	<p>Default = Off for users with call appearance buttons/On for other users. </p> <p>If on, when the user has a call on hold, new calls receive busy treatment. They will follow the user's forward on busy setting or are diverted to voicemail. Otherwise busy tone (ringing for incoming analog calls) is played. This overrides call waiting when the user has a call on hold. The use of <b>Busy on Held</b> for users with multiple call appearance buttons is deprecated and Manager will prompt whether it should switch off the feature off for such a user.</p>

*Table continues...*

Field	Description
<b>Offhook Station</b>	<p>Default = Off</p> <p>Off-hook station allows an analog extension to be left permanently off-hook, with calls being made and answered using an application or TAPI. When enabled, the analog extension user is able to control calls using the application in the following ways:</p> <p>Offhook station does not disable the physical off-hook on the phone. When starting with the phone on-hook, making and answering calls is the same as normal analog extension operation. Additionally however calls can be initiated from the application. After entering the required number and making the call, the on-hook analog extension receives a ringback showing the users own caller ID and when answered the outgoing call leg to the dialed number is started. Calls to a busy destination present busy tone before being cleared.</p> <p>The application can be used to end a call with the analog extension still off-hook. Instead of hearing disconnect tone the user hears silence and can use the application to make another call. Though off-hook the user is indicated as idle on BLF indicators. Without off-hook Station set the user would be indicated as busy when off-hook, whether on a call or not.</p> <p>If off-hook and idle (having cleared a previous call), incoming call alerts by presenting ringing through the audio path. The call can be answered using the application or going on-hook/off-hook or by pressing recall. Note that if the phone normally displays call ID, any caller ID displayed on the phone is not updated in this mode, however the call ID in the application will be that of the current call.</p> <p>If on-hook, an incoming call alerts as normal using the phone's ringer and is answered by going off-hook. The answer call option in the application cannot be used to answer calls to an on-hook analog extension.</p> <p>While off-hook and idle, the analog extension user will receive page calls.</p> <p>If the analog extension handset is replaced with a headset, changing the Manager setting <b>Extension   Analog   Equipment Classification</b> to <b>Quiet Handset</b> is recommended.</p>

**Related links**

[Telephony](#) on page 435

**Supervisor Settings**

Navigation: **User | Telephony | Supervisor Settings**

**Additional configuration information**

- For additional information on the **Force Authorization Code** setting, see [Configuring Authorization Codes](#) on page 656.
- For additional information on the **Inhibit Off-Switch Forward/Transfers** see, [Off-Switch Transfer Restrictions](#) on page 731.

**Configuration settings**





These settings relate to user features normally only adjusted by the user's supervisor.

The  symbol indicates that the setting can also be set by the user rights with which the user is associated. The user rights can be controlled by a time profile selected as the user's Working Hours Time Profile setting.

These settings are mergeable. Changes to these settings do not require a reboot of the system.







Field	Description
<b>Login Code</b>	<p>Default = Blank. Range = Up to 31 digits.</p> <p>The code that has to be entered, as part of a log in sequence, to allow a user to make use of an extension as if it was their own phone. This entry must be at least 4 digits for DS port users. Login codes of up to 15 digits are supported with Extn Login buttons. Login codes of up to 31 digits are supported with Extn Login short codes. Centralized users use the <b>Login Code</b> for SIP registration on Session Manager.</p> <ul style="list-style-type: none"> <li>• For IP phone users, the login code should be limited to 13 digits. The user's login code is used by IP phones during registration with the system.</li> <li>• This log in code can be used for hot desking as well as logging back onto your phone after it has been used by a hot desking user. Hot desking is not supported for centralized users.</li> <li>• Users can only log out if they have a <b>Login Code</b> set. Users can log out without having a <b>Login Code</b> set if they are currently logged in at an extension whose Base Extension Number (<b>Extension   Extn</b>) no longer matches their own Extension (<b>User   User</b>).</li> <li>• Supports the short code feature Change Login Code.</li> <li>• If the user has a login code set, it is used by the Outgoing Call Bar Off short code feature.</li> <li>• If the user has a login code set, access to a range of programmable button features will require entry of the login code. For example access Self Admin and <b>System Phone</b> features.</li> </ul>
<b>Login Idle Period (secs)</b>	<p>Default = Blank (Off). Range = 0 (Off) to 99999.</p> <p>If the telephone is not used for this period; the user currently logged in is automatically logged out. This option should be used only in conjunction with Force Login (see below).</p>
<b>Monitor Group</b>	<p>Default = &lt;None&gt;</p> <p>Sets the hunt group whose members the user can monitor if silent monitoring is setup. See the Call Listen short code.</p>
<b>Privacy Override Group</b>	<p>Default = &lt;None&gt;</p> <p>The drop-down menu lists the local and network advertised hunt groups. If selected, calls to this user cannot be seen or picked up by other users unless they are a member of the selected group.</p>
<b>Coverage Group</b>	<p>Default = &lt;None&gt;. </p> <p>If a group is selected, then in scenarios where an external call would normally have gone to voicemail, it instead continues ringing and also starts alerting the members of the coverage group. For further details refer to Coverage Groups.</p>

*Table continues...*

Field	Description
<b>Status on No Answer</b>	<p>Default = Logged On.</p> <p>Hunt groups can change the status of call center agents (users with a log in code and set to forced log in) who do not answer a hunt group call presented to them before it is automatically presented to the next agent. Use of this is controlled by the <b>Agent's Status on No Answer Applies To</b> setting of the hunt group. This option is not used for calls ringing the agent because the agent is in another group's overflow group. The options are:</p> <ul style="list-style-type: none"> <li>• <b>Logged On:</b> If this option is selected, the user's status is not changed.</li> <li>• <b>Busy Wrap-Up:</b> If this option is selected the user's membership status of the hunt group triggering the action is changed to disabled. The user can still make and receive calls and will still continue to receive calls from other hunt groups to which they belong.</li> <li>• <b>Busy Not Available:</b> If this option is selected the user's status is changed to do not disturb. This is the equivalent of DND and will affect all calls to the user.</li> <li>• <b>Logged Off:</b> If this option is selected the users status is changed to logged out. In that state they cannot make calls or receive calls. Hunt group calls go to the next available agent and personal calls treat the user as being busy.</li> </ul>
<b>Reset Longest Idle Time</b>	<p>Default = All Calls.</p> <p>This setting is used in conjunction with hunt groups set to Longest Waiting (also known as Idle and Longest Waiting). It defines what type of calls reset the idle time of users who are members of these hunt groups. Options are <b>All Calls</b> and <b>External Incoming</b>.</p>
<b>ICR Agent Role</b>	<p> <b>Note:</b></p> <p>This field is available only if you first configure the user as an Integrated Contact Reporter (ICR) user using the <b>ICR Agent</b> field, which is provided near the end.</p> <p>Default = Agent.</p> <p>Select <b>Supervisor</b> to make the user a supervisor. Selecting <b>Supervisor</b> displays the <b>Enable Huntgroup Monitoring</b> area and lists all the hunt groups available for the supervisor to monitor. The hunt groups are listed only if they were already configured. Select the hunt groups for supervisor to monitor.</p> <p> <b>Note:</b></p> <p>Integrated Contact Reporter is not supported in IP Office Release 11.0.</p>
<b>Force Login</b>	<p>Default = Off </p> <p>If checked, the user must log in using their Login Code to use any extension including an extension to which they are the default associated user (Base Extension). For example, if Force Login is ticked for user A and user B has logged onto A's phone, when B logs off user A is not automatically associated with their normal phone and instead must log back on. If Force Login was not ticked, A would be automatically logged back in.</p>
<b>Force Account Code</b>	<p>Default = Off </p> <p>If checked, the user must enter a valid account code to make an external call.</p>

*Table continues...*



Field	Description
<b>Force Authorization Code</b>	Default = Off. If checked, the user must enter a valid authorization code to make an external call. That authorization code must be one associated with the user or the user rights to which the user belongs.
<b>Incoming Call Bar</b>	Default = Off  When enabled, this setting stops a user from receiving any external calls. On the calling phone, the call is rejected.
<b>Outgoing Call Bar</b>	Default = Off  When enabled, this setting stops a user from making any external calls except those that use dial emergency features. On many Avaya display phones, this causes a <b>B</b> to be displayed. The following features can be used with outgoing call bar: Outgoing Call Bar On, Outgoing Call Bar Off and Change Login Code.
<b>Inhibit Off-Switch Forward/Transfers</b>	Default = Off. When enabled, this setting stops the user from transferring or forwarding calls externally. This does not stop another user transferring the restricted users calls off-switch on their behalf. Note that a number of other controls may inhibit the transfer operation.
<b>Can Intrude</b>	Default = Off  Check this option if the user can join or interrupt other user's calls using call intrusion methods other than conferencing.
<b>Cannot be Intruded</b>	Default = On  If checked, this user's calls cannot be interrupted or acquired by other internal users using call intrusion. For users with <b>Cannot Be Intruded</b> off, private call can be used to indicate whether a call can be intrude or not.
<b>Can Trace Calls</b>	Default = Off. This settings controls whether the user is able to make used of ISDN MCID controls.
<b>ICR Agent</b>	Default = Off. Enable to make the user an ICR user. If enabled, the <b>ICR Agent Role</b> field becomes available and the After Call Work related fields are activated.   <b>Note:</b> Integrated Contact Reporter is not supported in IP Office Release 11.0.
<b>Automatic After Call Work</b>	Default = Off. If enabled, the agent goes into After Call Work (ACW) at the end of an ICR and non-ICR hunt group call to indicate that they are busy with post-call processing activity. During the ACW state, they are not sent any hunt group calls.   <b>Note:</b> Integrated Contact Reporter is not supported in IP Office Release 11.0.

*Table continues...*

Field	Description
<b>Can Control After Call Work</b>	Default = Off. If enabled, the agent can extend the currently active After Call Work time indefinitely.
<b>After Call Work Time (Sec)</b>	Default = The value in this field is populated from the <b>Default After Call Work Time</b> field located at <b>System   Contact Center</b> .  The time after a call when an agent is busy and unable to deal with hunt group calls. Change the value if you want to specify ACW time for this user to be different from the system default.
<b>Can Accept Collect Calls</b>	Default = Off [Brazil Only] Determines whether the user is able to receive and accept collect calls.
<b>Deny Auto Intercom Calls</b>	Default = Off. When enabled, any automatic intercom calls to the user's extension are automatically turned into normal calls.
<b>Enable Hunt group Monitoring</b>	Default = Blank All the available hunt groups for Integrated Contact Reporter are listed under <b>Hunt Group Name</b> . Select the check box against the hunt group to enable it for monitoring by the supervisor. Select the <b>Hunt Group Name</b> check box to enable all the hunt groups for monitoring by the supervisor. The field is activated if you assign the user with Supervisor role using the <b>ICR Agent Role</b> field.   <b>Note:</b> Integrated Contact Reporter is not supported in IP Office Release 11.0.

**Related links**

[Telephony](#) on page 435

**Multi-line Options**

Navigation: **User | Telephony | Multi-line Options**

**Additional configuration information**

- For additional configuration information, see [Appearance Button Operation](#) on page 1079.
- For the **Reserve Last CA** setting, 1400, 1600, 9500 and 9600 Series telephone users can put a call on hold pending transfer if they already have held calls even if they have no free call appearance button available. For additional information, see [Context Sensitive Transfer](#) on page 732.

**Configuration settings**

Multi-line options are applied to a user's phone when the user is using an Avaya phones which supports appearance buttons (call appearance, line appearance, bridged and call coverage).

The  symbol indicates that the setting can also be set by the user rights with which the user is associated. The user rights can be controlled by a time profile selected as the user's Working Hours Time Profile setting.

These settings are mergeable. Changes to these settings do not require a reboot of the system.

Field	Description																
<b>Individual Coverage Time (secs)</b>	<p>Default = 10 seconds, Range 1 to 99999 seconds. 📞</p> <p>This function sets how long the phone will ring at your extension before also alerting at any call coverage users. This time setting should not be equal to or greater than the <b>No Answer Time</b> applicable for the user.</p>																
<b>Ring Delay</b>	<p>Default = Blank (Use system setting). Range = 0 (use system setting) to 98 seconds.</p> <p>This setting is used when any of the user's programmed appearance buttons is set to Delayed ringing. Calls received on that button will initially only alert visually. Audible alerting will only occur after the ring delay has expired.</p>																
<b>Coverage Ring</b>	<p>Default = Ring.</p> <p>This field selects the type of ringing that should be used for calls alerting on any the user's call coverage and bridged appearance buttons. <b>Ring</b> selects normal ringing. <b>Abbreviated Ring</b> selects a single non-repeated ring. <b>No Ring</b> disables audible ringing. Note that each button's own ring settings (<b>Immediate</b>, <b>Delayed Ring</b> or <b>No Ring</b>) are still applied.</p> <p>The ring used for a call alerting on a call coverage or bridged appearance button will vary according to whether the user is currently connected to a call or not.</p> <ul style="list-style-type: none"> <li>• If not currently on a call, the <b>Coverage Ring</b> setting is used.</li> <li>• If currently on a call, the quieter of the <b>Coverage Ring</b> and <b>Attention Ring</b> settings is used.</li> </ul> <table border="1" data-bbox="391 953 1482 1157"> <thead> <tr> <th>Attention Ring Setting</th> <th colspan="3">Coverage Ring Setting</th> </tr> <tr> <td></td> <th>Ring</th> <th>Abbreviated</th> <th>Off</th> </tr> </thead> <tbody> <tr> <th>Ring</th> <td>Ring</td> <td>Abbreviated</td> <td>Off</td> </tr> <tr> <th>Abbreviated</th> <td>Abbreviated</td> <td>Abbreviated</td> <td>Off</td> </tr> </tbody> </table>	Attention Ring Setting	Coverage Ring Setting				Ring	Abbreviated	Off	Ring	Ring	Abbreviated	Off	Abbreviated	Abbreviated	Abbreviated	Off
Attention Ring Setting	Coverage Ring Setting																
	Ring	Abbreviated	Off														
Ring	Ring	Abbreviated	Off														
Abbreviated	Abbreviated	Abbreviated	Off														
<b>Attention Ring</b>	<p>Default = Abbreviated Ring. This field selects the type of ringing that should be used for calls alerting on appearance buttons when the user already has a connected call on one of their appearance buttons. <b>Ring</b> selects normal ringing. <b>Abbreviated Ring</b> selects a single ring. Note that each button's own ring settings (<b>Immediate</b>, <b>Delayed Ring</b> or <b>No Ring</b>) are still applied.</p>																
<b>Ringing Line Preference</b>	<p>Default = On.</p> <p>For users with multiple appearance buttons. When the user is free and has several calls alerting, ringing line preference assigns currently selected button status to the appearance button of the longest waiting call. Ringing line preference overrides idle line preference.</p>																
<b>Idle Line Preference</b>	<p>Default = On. For users with multiple appearance buttons. When the user is free and has no alerting calls, idle line preference assigns the currently selected button status to the first available appearance button.</p>																

Table continues...

Field	Description
<b>Delayed Ring Preference</b>	<p>Default = Off.</p> <p>This setting is used in conjunction with appearance buttons set to delayed or no ring. It sets whether ringing line preference should use or ignore the delayed ring settings applied to the user's appearance buttons.</p> <p>When on, ringing line preference is only applied to alerting buttons on which the ring delay has expired.</p> <p>When off, ringing line preference can be applied to an alerting button even if it has delayed ring applied.</p>
<b>Answer Pre-Select</b>	<p>Default = Off.</p> <p>Normally when a user has multiple alerting calls, only the details and functions for the call on currently selected button are shown. Pressing any of the alerting buttons will answer the call on that button, going off-hook will answer the currently selected button. Enabling <b>Answer Pre-Select</b> allows the user to press any alerting button to make it the current selected button and displaying its call details without answering that call until the user either presses that button again or goes off-hook. Note that when both <b>Answer Pre-Select</b> and <b>Ringing Line Preference</b> are enabled, once current selected status is assigned to a button through ringing line preference it is not automatically moved to any other button.</p>
<b>Reserve Last CA</b>	<p>Default = Off.</p> <p>Used for users with multiple call appearance buttons. When selected, this option stops the user's last call appearance button from being used to receive incoming calls. This ensures that the user always has a call appearance button available to make an outgoing call and to initiate actions such as transfers and conferences.</p> <p>1400, 1600, 9500 and 9600 Series telephone users can put a call on hold pending transfer if they already have held calls even if they have no free call appearance button available.</p>

**Related links**

[Telephony](#) on page 435

**Call Log**

Navigation: **User | Telephony | Call Log**



The system can store a centralized call log for users. Each users' centralized call log can contain up to 30 call records for user calls. When this limit is reached, each new call records replaces the oldest previous record.

On Avaya phones with a fixed **Call Log** or **History** button (1400, 1600, 9500 and 9600 Series), that button can be used to display the user's centralized call log. The centralized call log is also used for M-Series and T-Series phone. The user can use the call log to make calls or to store as a personal speed dial. They can also edit the call log to remove records. The same call log is also used if the user logs into one-X Portal.

The centralized call log moves with the user if they log on and off from different phones. This includes if they hot desk within a network.

The  symbol indicates that the setting can also be set by the user rights with which the user is associated. The user rights can be controlled by a time profile selected as the user's Working Hours Time Profile setting.

These settings are mergeable. Changes to these settings do not require a reboot of the system.

Field	Description
<b>Centralized Call Log</b>	<p>Default = System Default (On) </p> <p>This setting allows the use of centralized call logging to be enabled or disabled on a per user basis. The default is to match the system setting <b>System   Telephony   Call Log   Default Centralized Call Log On</b>.</p> <p>The other options are <b>On</b> or <b>Off</b> for the individual user. If set to <b>Off</b>, the user receives the message "Call Log Disabled" when the Call Log button is pressed.</p>
<b>Delete records after (hours:minutes)</b>	<p>Default = 00:00 (Never). </p> <p>If a time period is set, records in the user's call log are automatically deleted after this period.</p>
<b>Groups</b>	<p>Default = System Default (On). </p> <p>This section contains a list of hunt groups on the system. If the system setting <b>System   Telephony   Call Log   Log Missed Huntgroup Calls</b> has been enabled, then missed calls for those groups selected are shown as part of the users call log. The missed calls are any missed calls for the hunt group, not just group calls presented to the user and not answered by them.</p>

### Related links

[Telephony](#) on page 435

## TUI

Navigation: **User | Telephony | TUI**

Used to configure system wide telephony user interface (TUI) options for 1400, 1600, 9500, 9600 and J100 Series phones (except the J129).

These settings are mergeable. Changes to these settings do not require a reboot of the system.

Field	Description
<b>Features Menu Controls</b>	
<b>User Setting</b>	<p>Default = Same as System</p> <p>When set to <b>Same as System</b>, matches the system-wide settings of the System   Telephony   TUI menu options. When set to <b>Custom</b>, uses the <b>Features Menu</b> settings below.</p>

*Table continues...*

Field	Description
<b>Features Menu</b>	<p>Default = On</p> <p>When set to off, TUI feature menus are not available. When set to on, you can select to turn individual feature menus off or on. The following feature menus are listed:</p> <ul style="list-style-type: none"> <li>• <b>Basic Call Functions:</b> If selected, the user can access menu options for call pickup, park, unpark and transfer to mobile functions.</li> <li>• <b>Advanced Call Functions:</b> If selected, the user can access the menu options for do not disturb, account code, withhold number and internal auto-answer functions. Note, the <b>Account Code</b> menu is only shown if the system has been configured with accounts codes.</li> <li>• <b>Forwarding:</b> If selected, the user the phone's menus for forwarding and follow me functions.</li> <li>• <b>Hot Desk Functions:</b> If selected, the user can access the menu options for logging in and out.</li> <li>• <b>Passcode Change:</b> If selected, the user can change their login code (security credentials) through the phone menus..</li> <li>• <b>Phone Lock:</b> If selected, the user can access the menu options for locking the phone and for setting it to automatically lock.</li> <li>• <b>Self Administration:</b> If selected, the user can access the phone's <b>Self-Administration</b> menu options.</li> <li>• <b>Voicemail Controls:</b> If set, the user can access the <b>Visual Voice</b> option through the phone's <b>Features</b> menu.</li> </ul>

**Related links**

[Telephony](#) on page 435

---

## User | Forwarding

Navigation: **User | Forwarding**

### Additional configuration information

For additional configuration information, see [DND, Follow Me, and Forwarding](#) on page 685.

### Configuration settings

Use this page to check and adjust a user's call forwarding and follow me settings.

Follow Me is intended for use when the user is present to answer calls but for some reason is working at another extension. For example; temporarily sitting at a colleague's desk or in another office or meeting room. As a user, you would use Follow Me instead of Hot-Desking if you don't have a log in code or you don't want to interrupt you colleague also receiving their own calls. Multiple users can use follow me to the same phone.

Forwarding is intended for use when, for some reason, the user is unable to answer a call. They may be busy on other calls, unavailable or simply don't answer. Calls may be forwarded to internal or, subject to the user's call barring controls, external numbers.

To bar a user from forwarding calls to an external number, select the setting **User | Telephony | Supervisor Settings | Inhibit Off-Switch Forward/Transfers**.

To bar all users from forwarding calls to external numbers, select the setting **System | Telephony | Telephony | Inhibit Off-Switch Forward/Transfers**.

Note that analog lines do not provide call progress signalling. Therefore calls forwarded off-switch via an analog line are treated as answered and are not recalled.

Once a call has been forwarded to an internal target, it will ignore the target's **Forward No Answer** or **Forward on Busy** settings but may its **Forward Unconditional** settings unless they create a loop.

The  symbol indicates that the setting can also be set by the user rights with which the user is associated. The user rights can be controlled by a time profile selected as the user's Working Hours Time Profile setting.

These settings are mergeable. Changes to these settings do not require a reboot of the system.

Field	Description
<b>Block Forwarding</b>	<p>Default = Off. </p> <p>When enabled, call forwarding is blocked for this user.</p> <p>The following actions are blocked: Follow me, Forward unconditional, Forward on busy, Forward on no answer and Hot Desking</p> <p>The following actions are not blocked: <b>Do not disturb</b>, Voicemail and Twinning</p>
<b>Follow Me Number</b>	<p>Default = Blank. Range = Internal extension number.</p> <p>Redirects the user's calls to the internal extension number entered. If the redirected call receives busy or is not answered, it follows the user's forwarding and or voicemail settings as if it had been presented to their normal extension. When a user has follow me in use, their normal extension will give alternate dialtone when off hook. Using <b>Follow Me</b> overrides <b>Forward Unconditional</b>.</p> <p>Calls targeting longest waiting type hunt groups ignore Follow Me.</p> <p>Calls triggered by actions at the user's original extension, for example voicemail ringback, ignore Follow Me.</p> <p>Park, hold and transfer return calls will go to the extension at which the user initiated the park, hold or transfer action.</p>

*Table continues...*

Field	Description
<p><b>Forward Unconditional</b></p>	<p>Default = Off</p> <p>This option, when checked and a <b>Forward Number</b> also set, forwards all external calls immediately. Additional options allow this forwarding to also be applied to internal calls and to hunt group calls if required. When a user has forward unconditional in use, their normal extension will give alternate dialtone when off hook. If the destination is an internal user on the same system, they are able to transfer calls back to the user, overriding the Forward Unconditional.</p> <p>After being forwarded for the user's no answer time, if still unanswered, the system can apply additional options. It does this if the user has forward on no answer set for the call type or if the user has voicemail enabled.</p> <ul style="list-style-type: none"> <li>• If the user has forward on no answer set for the call type, the call is recalled and then forwarded to the forward on no answer destination.</li> <li>• If the user has voicemail enabled, the call is redirected to voicemail.</li> <li>• If the user has both options set, the call is recalled and then forwarded to the forward on no answer destination for their no answer time and then if still unanswered, redirected to voicemail.</li> <li>• If the user has neither option set, the call remains redirected by the forward unconditional settings.</li> </ul> <p>Note that for calls redirected via external trunks, detecting if the call is still unanswered requires call progress indication. For example, analog lines do not provide call progress signalling and therefore calls forwarded via an analog lines are treated as answered and not recalled.</p>
<p><b>To Voicemail</b></p>	<p>Default = Off.</p> <p>If selected and forward unconditional is enabled, calls are forwarded to the user's voicemail mailbox. The <b>Forward Number</b> and <b>Forward Hunt Group Calls</b> settings are not used. This option is not available if the system's <b>Voicemail Type</b> is set to <b>None</b>. 1400, 1600, 9500 and 9600 Series phone users can select this setting through the phone menu. Note that if the user disables forward unconditional the <b>To Voicemail</b> setting is cleared.</p>
<p><b>Forward Number</b></p>	<p>Default = Blank. Range = Internal or External number. Up to 33 characters.</p> <p>This option sets the destination number to which calls are forwarded when <b>Forward Unconditional</b> is checked. The number can be an internal or external number. This option is also used for <b>Forward on Busy</b> and <b>Forward on No Answer</b> if no separate <b>Forward Number</b> is set for those features. If a user forwards a call to a hunt group of which they are a member, the group call is not presented to them but is presented to other members of the hunt group.</p>

*Table continues...*



Field	Description
<b>Forward Hunt Group Calls</b>	<p>Default = Off</p> <p>Hunt group calls (internal and external) are not normally presented to a user who has forward unconditional active. Instead they are presented to the next available member of the hunt group. This option, when checked, sets that hunt group calls (internal and external) are also forwarded when forward unconditional is active. The group's <b>Ring Type</b> must be <b>Sequential</b> or <b>Rotary</b>, not <b>Collective</b> or <b>Longest Waiting</b>. The call is forwarded for the period defined by the hunt group's <b>No Answer Time</b> after which it returns to the hunt group if unanswered. Note also that hunt group calls cannot be forwarded to another hunt group.</p>
<b>Forward Internal Calls</b>	<p>Default = On.</p> <p>This option, when checked, sets that internal calls should be also be forwarded immediately when forward unconditional is active.</p>
<b>Forward On Busy</b>	<p>Default = Off</p> <p>When checked and a forward number is set, external calls are forwarded when the user's extension is busy. The number used is either the <b>Forward Number</b> set for <b>Forward Unconditional</b> or if set, the separate <b>Forward Number</b> set under <b>Forward On Busy</b>. Having <b>Forward Unconditional</b> active overrides <b>Forward on Busy</b>.</p> <p>If the user has <b>Busy on Held</b> selected, if forward on busy is active it is applied when the user is free to receive calls but already has a call on hold.</p> <p>If the user's phone has multiple call appearance buttons, the system will not treat them as busy until all the call appearance buttons are in use unless the last appearance button has been reserved for outgoing calls only.</p>
<b>Forward On No Answer</b>	<p>Default = Off</p> <p>When checked and a forward number is set, calls are forwarded when the user does not answer within their set No Answer Time (User   Telephony   Call Settings).</p>
<b>Forward Number</b>	<p>Default = Blank. Range = Internal or External number. Up to 33 characters.</p> <p>If set, this number is used as the destination for <b>Forward On Busy</b> and <b>Forward On No Answer</b> when on. If not set, the <b>Forward Number</b> set for <b>Forward Unconditional</b> is used. If a user forwards a call to a hunt group of which they are a member, the group call is not presented to them but is presented to other members of the hunt group.</p>
<b>Forward Internal Calls</b>	<p>Default = On. When checked, this option sets that internal calls should be also be forwarded when forward on no answer or forward on busy is active.</p>

### Related links

[User](#) on page 413

---

## Dial In

Navigation: **User | Dial In**

Use this dialogue box to enable dial in access for a remote user. An Incoming Call Route and RAS service must also be configured.

These settings are mergeable. Changes to these settings do not require a reboot of the system.

Field	Description
<b>Dial In On</b>	Default = Off When enabled, dial in access into the system is available via this user.
<b>Dial In Time Profile</b>	Default = <None> Select the Time Profile applicable to this User account. A <b>Time Profile</b> can be used to set time restrictions on dial in access via this User account. Dial In is allowed during the times set in the Time Profile form. If left blank, then there are no restrictions.
<b>Dial In Firewall Profile</b>	Default = <None> Select the Firewall Profile to restrict access to the system via this User account. If blank, there are no Dial In restrictions.

**Related links**

[User](#) on page 413

## Voice Recording

Navigation: **User | Voice Recording**

Used to activate the automatic recording of user's external calls. The recording of internal calls is also supported.

Call recording requires Voicemail Pro to be installed and running. Call recording also requires available conference resources similar to a 3-way conference.

Note the following:

- Calls to and from IP devices, including those using Direct media, can be recorded.
- Calls parked or held pause recording until the unparked or taken off hold (does not apply to SIP terminals).
- Call recording end time:  
User voice recording continues for the duration of the call on the system or up to the maximum recording time configured on the voicemail server.
- Recording is stopped if:
  - User recording stops if the call is transferred to another user.
  - User account code recording stops if the call is transferred to another user.
  - Hunt group recording stops if the call is transferred to another user who is not a member of the hunt group.

These settings are mergeable. Changes to these settings do not require a reboot of the system.

Field	Description
<b>Auto Recording</b>	
<b>Inbound</b>	<p>Default = None.</p> <p>Select whether automatic recording of incoming calls is enabled. The field to the right sets whether just external, just internal, or both external and internal calls are included. The options are:</p> <ul style="list-style-type: none"> <li>• <b>None:</b> Do not automatically record calls.</li> <li>• <b>On:</b> Record the call if possible. If not possible to record, allow the call to continue.</li> <li>• <b>Mandatory:</b> Record the call if possible. If not possible to record, block the call and return busy tone.</li> <li>• <b>Percentages of calls:</b> Record a selected percentages of the calls.</li> </ul>
<b>Outbound</b>	<p>Default = None.</p> <p>Select whether automatic recording of out going calls is enabled. The field to the right sets whether just external, just internal, or both external and internal calls are included. The options are:</p> <ul style="list-style-type: none"> <li>• <b>None:</b> Do not automatically record calls.</li> <li>• <b>On:</b> Record the call if possible. If not possible to record, allow the call to continue.</li> <li>• <b>Mandatory:</b> Record the call if possible. If not possible to record, block the call and return busy tone.</li> <li>• <b>Percentages of calls:</b> Record a selected percentages of the calls.</li> </ul>
<b>Destination</b>	<p>Default = None.</p> <p>Sets the destination for automatically triggered recordings. The options are:</p> <ul style="list-style-type: none"> <li>• <b>Voice Recording Library:</b> This options set the destination for the recording to be a VRL folder on the voicemail server. The ContactStore application polls that folder and collects waiting recordings which it then places in its own archive. Recording is still done by Voicemail Pro.</li> <li>• <b>Voice Recording Library Authenticated:</b> This option is similar to Voice Recording Library above but instructs the voicemail server to create an authenticated recording. If the file contents are changed, the file is invalidated though it can still be played. This option is not currently supported with Linux based systems.</li> </ul>
<b>Time Profile</b>	<p>Default = None. (Any time).</p> <p>Used to select a time profile during which automatic call recording of incoming calls is applied. If no profile is selected, automatic recording of incoming calls is active at all times.</p>
<b>Manual Recording</b>	

*Table continues...*

Field	Description
<b>Destination</b>	<p>Default = None.</p> <p>Sets the destination for automatically triggered recordings. The options are:</p> <ul style="list-style-type: none"> <li>• <b>Voice Recording Library:</b> This options set the destination for the recording to be a VRL folder on the voicemail server. The ContactStore application polls that folder and collects waiting recordings which it then places in its own archive. Recording is still done by Voicemail Pro.</li> <li>• <b>Voice Recording Library Authenticated:</b> This option is similar to Voice Recording Library above but instructs the voicemail server to create an authenticated recording. If the file contents are changed, the file is invalidated though it can still be played.</li> </ul>

**Related links**

[User](#) on page 413

## Button Programming

Navigation: [User](#) | **Button Programming**

### Additional configuration information

For additional information on programming button actions, see [Button Programming Overview](#) on page 921.

For a description of each button action, see [Button Programming Actions](#) on page 933.

Used to assign functions to the programmable keys provided on many Avaya telephones. For full details of button programming refer to the section Button Programming.

These settings are mergeable. Changes to these settings do not require a reboot of the system.

Field	Description
<b>Button No.</b>	The number of the DSS key against which the function is being set. To set a function against a button double-click it or select it and then click <b>Edit</b> .
<b>Label</b>	This is a text label for display on the phone. If no label is entered, the default label for the selected action is used.
<b>Action</b>	Defines the action taken by the menu item.
<b>Action Data</b>	This is a parameter used by the selected action. The options here will vary according to the selected button action.
<b>Display All</b>	The number of button displayed is based on the phone associated with the user when the configuration was loaded. This can be overridden by selecting <b>Display All Buttons</b> . This may be necessary for users who switch between different phones using hot desking or have an expansion unit attached to their phone.

**Related links**

[User](#) on page 413

## User | Menu Programming

Navigation: **User | Menu Programming**

These menus control a range of options that are specific to different types of phones. The functions become accessible when the user logs in on the appropriate type of phone.

### Related links

[User](#) on page 413

[Huntgroup](#) on page 453

[4400/6400](#) on page 453

## Huntgroup

Navigation: **User | Menu Programming | Hunt Group**

Avaya 1400, 1600, 9500 and 9600 Series phone users can control various settings for selected hunt groups. These settings are also used for one-X Portal for IP Office.

These settings are mergeable. Changes to these settings do not require a reboot of the system.

Field	Description
<b>Can Change Membership</b>	Default = Off  This list shows the hunt groups of which the user is a member. Up to 10 of these groups can be checked; those group and the users current membership status are then displayed on the phone. The user can change their membership status through the phone's menus.
<b>Can Change Service Status</b>	Default = Off  This list shows all the hunt groups on the system. Up to 10 of these groups can be checked.
<b>Can Change Night Service Group</b>	Default = Off.  If selected, the user can change the fallback group used when the hunt group is in Night Service mode.
<b>Can Change Out of Service Group</b>	Default = Off. If selected, the user can change the fallback group used when the hunt group is in Out of Service mode.

### Related links

[User | Menu Programming](#) on page 453

## 4400/6400

Navigation: **User | Menu Programming | 4400/6400**

4412, 4424, 4612, 4624, 6408, 6416 and 6424 phones have a **Menu** key, sometimes marked with an  icon. When **Menu** is pressed, a number of default functions are displayed. The < and > keys can be used to scroll through the functions while the keys below the display can be used to select the required function.

The default functions can be overwritten by selections made within this tab.

These settings are mergeable. Changes to these settings do not require a reboot of the system.

Field	Description
<b>Menu No.</b>	The menu position which the function is being set.
<b>Label</b>	This is a text label for display on the phone. If no label is entered, the default label for the selected action is used. Labels can also be changed through the menu on some phones, refer to the appropriate telephone user guide.
<b>Action</b>	Defines the action taken by the menu button.
<b>Action Data</b>	This is a parameter used by the selected action. The options here will vary according to the selected button action.

**Related links**

[User | Menu Programming](#) on page 453

## Mobility

Navigation: **User | Mobility**

### Additional configuration information

For additional configuration information regarding the **Mobile Call Control** setting, see [Mobile Call Control](#) on page 718

### Configuration settings

These settings relate to twinning features where a user has a main or primary extension but also regularly answer calls at a secondary or twinned phone. These features are intended for a single user. They are not aimed at two users answering calls presented to a single primary extension.

Twinning allows a user's calls to be presented to both their current extension and to another number. The system supports two modes of twinning:

	Internal	Mobile
<b>Twinning Destination</b>	Internal extensions only	External numbers only.
<b>Supported in</b>	All locales.	All locales.
<b>License Required</b>	The primary phone user must be a licensed user.	Yes

The  symbol indicates that the setting can also be set by the user rights with which the user is associated. The user rights can be controlled by a time profile selected as the user's Working Hours Time Profile setting.

These settings are mergeable. Changes to these settings do not require a reboot of the system.

Field	Description
<b>Internal Twinning</b>	Select this option to enable internal twinning for a user. <b>Internal Twinning</b> cannot be selected for a user if they already have <b>Mobility Features</b> selected. Internal twinning is not supported across an SCN or SE network. Internal twinning is not supported during resilience.
<b>Twinned Handset</b>	<p>Default = Blank.</p> <p>For internal twinning, the drop-down list can be used to select an available user as the twinned calls destination. The secondary phone:</p> <ul style="list-style-type: none"> <li>• must be on the same system</li> <li>• must not be a simultaneous mode phone. For example, Avaya Communicator (for Windows, iPad, or Web), or WebRTC web client.</li> </ul> <p>If the list is grayed out, the user is a twinning destination and the primary to which they are twinned is displayed.</p> <p>All <b>User   Mobility</b> fields are grayed out for unlicensed users.</p>
<b>Maximum Number of Calls</b>	<p>Default = 1.</p> <p>If set to one, when either the primary or secondary phone are in use, any additional incoming call receives busy treatment. If set to two, when either phone is in use, it receives call waiting indication for any second call. Any further calls above two receive busy treatment.</p>
<b>Twin Bridge Appearances</b>	<p>Default = Off.</p> <p>By default only calls alerting on the primary phone's call appearance buttons also alert at the secondary. When this option is enabled, calls alerting on a bridged appearance button at the primary can also alert at the secondary.</p>
<b>Twin Coverage Appearances</b>	<p>Default = Off.</p> <p>By default only calls alerting on the primary phone's call appearance buttons also alert at the secondary. When this option is enabled, calls alerting on a coverage appearance button at the primary can also alert at the secondary.</p>
<b>Twin Line Appearances:</b>	<p>Default = Off.</p> <p>By default only calls alerting on the primary phone's call appearance buttons also alert at the secondary. When this option is enabled, calls alerting on a line appearance button at the primary can also alert at the secondary.</p>
<b>Mobility Features</b>	
If enabled this option allows any of the mobility features to be enabled for the user.	

*Table continues...*



Field	Description
<b>Mobile Twinning</b>	<p>If selected, the user is enable for mobile twinning. The user can control this option through a Twinning programmable button on their a phone.</p> <p>For user's setup for one-X Mobile Client, changes to their Mobile Twinning status made through the system configuration or using a <b>Twining</b> button are not reflected in the status of the <b>Extension to Cellular</b> icon on their mobile client. However, changes to the <b>Extension to Cellular</b> status made from the mobile client are reflected by the <b>Mobile Twinning</b> field in the system configuration. Therefore, for one-X Mobile Client users, it is recommended that they control their Mobile Twinning status through the one-X Mobile Client rather than through a <b>Twining</b> button.</p>
<b>Fallback Twinning</b>	<p>Default = Disabled</p> <p>When Fallback Twinning is enabled and the user's primary extensions are unreachable, IP Office redirects the calls to the Twinned Mobile Number even if Mobile Twinning is disabled. The Mobile Dial Delay time set up by the user is not considered during Fallback Twinning.</p>
<b>Twinned Mobile Number</b>	<p>Default = Blank.</p> <p>This field sets the external destination number for mobile twinned calls. It is subject to normal short code processing and should include any external dialing prefix if necessary. For users of Mobile Call Control, the number in this field is used to match the users setting to the incoming CLI.</p>
<b>Twining Time Profile</b>	<p>Default = &lt;None&gt; (Any time)</p> <p>This field allows selection of a time profile during which mobile twinning will be used.</p>
<b>Mobile Dial Delay</b>	<p>Default = 2 seconds </p> <p>This setting controls how long calls should ring at the user's primary extension before also being routed to ring at the twinning destination number. This setting may be used at the user's choice, however it may also be a necessary control. For example, if the twinning number is a mobile device that has been switched off, the mobile service provider may immediately answer the call with their own voicemail service. This would create a scenario where the user's primary extension does not ring or ring only briefly.</p>
<b>Mobile Answer Guard</b>	<p>Default = 0 (Off). Range = 0 to 99 seconds. This control can be used in situations where calls sent to the twinned destination are automatically answered by a voicemail service or automatic message if the twinned device is not available. If a twinned call is answered before the <b>Mobile Answer Guard</b> expires, the system will drop the call to the twin.</p>
<b>Hunt group calls eligible for mobile twinning</b>	<p>Default = Off </p> <p>This setting controls whether hunt group calls ringing the user's primary extension should also be presented to the mobile twinning number.</p>
<b>Forwarded calls eligible for mobile twinning</b>	<p>Default = Off  This setting controls whether calls forwarded to the user's primary extension should also be presented to the mobile twinning number.</p>

Table continues...



Field	Description
<b>Twin When Logged Out</b>	<p>Default = Off.</p> <p>If enabled, if the user logs off their primary extension, calls to that extension will still alert at their twinned device rather than going immediately to voicemail or busy.</p> <ul style="list-style-type: none"> <li>• When logged out but twinned, <b>Mobile Dial Delay</b> is not applied.</li> <li>• Hunt group calls (all types) will be twinned if <b>Hunt group calls eligible for mobile twinning</b> is enabled. When this is the case the user's idle time is reset for each externally twinned call answered. Note that calls twinned over analog and analog emulation trunks are automatically treated as answered.</li> <li>• When the user's <b>Mobile Time Profile</b>, if configured, is not active they will not get twinning calls. Calls will be treated the same as the user was logged out user with no twinning.</li> <li>• Callback calls initiated by the user will mature to the <b>Twinned Mobile Number</b>. It will also be possible to initiate Automatic Callback to the user with external twinning and their busy/free state will be tracked for all calls via the system.</li> <li>• Any Bridged Appearance set to the user will not alert. Coverage appearance buttons for the user will continue to operate.</li> <li>• The BLF/user button status shown for a logged out user with <b>Logged Off Mobile Twinning</b> is as follows: <ul style="list-style-type: none"> <li>- If there are any calls alerting or in progress through the system to the twin the user status is shown as alerting or in-use as appropriate. This includes the user showing as busy/in-use if they have such a call on hold and they have Busy on Held enabled.</li> <li>- If the user enables DND through Mobile Call Control or one-X Mobile client their status will show as DND/busy.</li> <li>- Calls from the system dialed direct to the users twinned destination rather than directed by twinning from their primary extension will not change the user's status.</li> </ul> </li> </ul>
<b>one-X Mobile Client</b>	<p>Default = Off.</p> <p>one-X Mobile Client is a software application that can be installed on Windows Mobile and Symbian mobile cell phones. It allows the user to access a number of system features.</p>
<b>Mobile Call Control</b>	<p>Default = Off.</p> <p>This feature allows a user receiving a call on their twinned device to access system dial tone and then perform dialing action including making calls and activating short codes. See the section "Mobile Call Control" in the chapter <b>Configure user settings in Administering Avaya IP Office™ Platform with Web Manager..</b></p>
<b>Mobile Callback</b>	<p>Default = Off.</p> <p>Mobile callback allows the user to call the system and then hang up. The system will then make a call to the user's CLI and when answered, provide them with dial tone from the system to make calls. See the Mobile Callback topic in <i>Administering Avaya IP Office™ Platform with Web Manager.</i></p>

### Related links

[User](#) on page 413

## Group Memberships

Navigation: **User | Group Membership**

This tab displays the hunt group of which the user has been made a member. The tick boxes indicate whether the user's membership of each of those groups is currently enabled or disabled.

### Related links

[User](#) on page 413

---

## Announcements

Navigation: **User | Announcements**

Announcements are played to callers waiting to be answered. This includes callers being presented to hunt group members, ie. ringing, and callers queued for presentation.

- The system supports announcements using Voicemail Pro or Embedded Voicemail.
- If no voicemail channel is available for an announcement, the announcement is not played.
- In conjunction with Voicemail Pro, the system allows a number of voicemail channels to be reserved for announcements. See **System | Voicemail**.
- With Voicemail Pro, the announcement can be replaced by the action specified in a Queued (1st announcement) or Still Queued (2nd announcement) start point call flow. Refer to the Voicemail Pro Installation and Maintenance documentation for details.
- Calls can be answered during the announcement. If it is a mandatory requirement that announcements should be heard before a call is answered, then a Voicemail Pro call flow should be used before the call is presented.

### **Note:**

#### Call Billing and Logging

A call becomes connected when the first announcement is played to it. That connected state is signaled to the call provider who may start billing at that point. The call will also be recorded as answered within the SMDR output once the first announcement is played.

- If a call is rerouted, for example forwarded, the announcement plan of the original user is still applied until the call is answered. The exception is calls rerouted to a hunt group at which point the hunt group announcement settings are applied.
- For announcements to be used effectively, either the user's no answer time must be extended beyond the default 15 seconds or Voicemail On should be deselected.

## Recording Announcements

### Voicemail Pro:

There is no mechanism within the telephony user interfaces (TUI) to record user announcements. To provide custom announcements, user queued and still queued start points must be configured with Voicemail Pro with the required prompts played by a generic action.

### Embedded Voicemail:

Embedded Voicemail does not include any default announcement or method for recording an announcement. The Record Message short code feature is provided to allow the recording of announcements. The telephone number field of short codes using this feature requires the extension number followed by either ".1" for announcement 1 or ".2" for announcement 2. For example, for extension number 300, the short codes **\*91N# | Record Message | N".1"** and **\*92N# | Record Message | N".2"** could be used to allow recording of the announcements by dialing **\*91300#** and **\*92300#**.

These settings are mergeable. Changes to these settings do not require a reboot of the system.

Field	Description
<b>Announcements On</b>	Default = Off. This setting enables or disables announcements.
<b>Wait before 1st announcement:</b>	Default = 10 seconds. Range = 0 to 255 seconds. This setting sets the time delay from the calls presentation, after which the first announcement should be played to the caller.
<b>Flag call as answered</b>	Default = Off. This setting is used by the CCC and CBC applications. By default they do not regard a call as answered until it has been answered by a person or by a Voicemail Pro action with <b>Flag call as answered</b> selected. This setting allows calls to be marked as answered once the caller has heard the first announcement.
<b>Post announcement tone</b>	Default = Music on hold. Following the first announcement, you can select whether the caller should hear Music on Hold, <b>Ringling</b> or <b>Silence</b> until answered or played another announcement.
<b>2nd Announcement</b>	Default = On. If selected, a second announcement can be played to the caller if they have still not been answered.
<b>Wait before 2nd announcement</b>	Default = 20 seconds. Range = 0 to 255 seconds. This setting sets the wait between the 1st and the 2nd announcement.
<b>Repeat last announcement</b>	Default = On. If selected, the last announcement played to the caller is repeated until they are answered or hang-up.
<b>Wait before repeat</b>	Default = 20 seconds. Range = 0 to 255 seconds. If <b>Repeat last announcement</b> is selected, this setting sets is applied between each repeat of the last announcement.

## Related links

[User](#) on page 413

---

## SIP

Navigation: [User](#) | [SIP](#)

This tab is available when either of the following has been added to the configuration:

- an **IP Office Line**
- a SIP trunk with a SIP URI record containing a field that has been set to **Use Internal Data**.

Various fields within the URI settings used by SIP trunks can be set to **Use Internal Data**. When that is the case, the values from this tab are used inserted into the URI when the user makes or receives a SIP call. Within a multi-site network, that includes calls which break out using a SIP trunk on another system within the network.

These settings are mergeable. Changes to these settings do not require a reboot of the system.

Field	Description
<b>SIP Name</b>	Default = Blank on Voicemail tab/Extension number on other tabs. The value from this field is used when the From field of the SIP URI being used for a SIP call is set to <b>Use Internal Data</b> .
<b>SIP Display Name (Alias)</b>	Default = Blank on Voicemail tab/Name on other tabs. The value from this field is used when the Display Name field of the SIP URI being used for a SIP call is set to <b>Use Internal Data</b> .
<b>Contact</b>	Default = Blank on Voicemail tab/Extension number on other tabs. The value from this field is used when the Contact field of the SIP URI being used for a SIP call is set to <b>Use Internal Data</b> .
<b>Anonymous</b>	Default = On on Voicemail tab/Off on other tabs. If the From field in the SIP URI is set to <b>Use Internal Data</b> , selecting this option inserts <b>Anonymous</b> into that field rather than the SIP Name set above.

#### Related links

[User](#) on page 413

---

## Personal Directory

Navigation: **User | Personal Directory**

Each user is able to have up to 250 personal directory records (100 pre-Release 10.0), up to the overall system limit.

These records are used as follows:

- When using ETR, J129, M-Series, T-Series, 1400, 1600, 9500 or 9600 Series phones, the user is able to view and call their personal directory numbers.
- When using a J129, 1400, 1600, 9500 or 9600 Series phone, the user is also able to edit and add personal directory records.
- If the user hot desks to a 1400, 1600, 9500 or 9600 Series phone on another system in a multi-site network, they can still access their personal directory.

Users are able to view and edit their personal directory through their phone. Directory records are used for dialing and caller name matching.

## Dialing

### Directory Dialing:

Directory numbers are displayed by user applications such as SoftConsole. Directory numbers are viewable through the Dir function on many Avaya phones (**Contacts** or **History**). They allow the user to select the number to dial by name. The directory will also contain the names and numbers of users and hunt groups on the system.

The **Dir** function groups directory records shown to the phone user into the following categories. Depending on the phone, the user may be able to select the category currently displayed. In some scenarios, the categories displayed may be limited to those supported for the function being performed by the user:

- **External** Directory records from the system configuration. This includes HTTP and LDAP imported records.
- **Groups** Groups on the system. If the system is in a multi-site network, it will also include groups on other systems in the network. For pre-Release 5 systems, this feature requires the systems to have **Advanced Small Community Networking** licenses.
- **Users** or **Index** Users on the system. If the system is in a multi-site network it will also include users on other systems in the network. For pre-Release 5 systems, this feature requires the systems to have **Advanced Small Community Networking** licenses.
- **Personal** Available on 1400, 1600, 9500 and 9600 Series phones. These are the user's personal directory records stored within the system configuration.

### Speed Dialing:

On M-Series and T-Series phones, a Speed Dial button or dialing **Feature 0** can be used to access personal directory records with an index number.

- **Personal**: Dial **Feature 0** followed by \* and the 2-digit index number in the range 01 to 99.
- **System**: Dial **Feature 0** followed by 3-digit index number in the range 001 to 999.
- The Speed Dial short code feature can also be used to access a directory speed dial using its index number from any type of phone.

### Caller Name Matching

Directory records are also used to associate a name with the dialled number on outgoing calls or the received CLI on incoming calls. When name matching is being done, a match in the user's personal directory overrides any match in the system directory. Note that some user applications also have their own user directory.

SoftConsole applications have their own user directories which are also used by the applications name matching. Matches in the application directory may lead to the application displaying a different name from that shown on the phone.

Name matching is not performed when a name is supplied with the incoming call, for example QSIG trunks. On SIP trunks the use of the name matching or the name supplied by the trunk can be selected using the setting **System | Telephony | Telephony | Default Name Priority**. This setting can also be adjusted on individual SIP lines to override the system setting.

Directory name matching is not supported for DECT handsets. For information on directory integration, see *IP DECT R4 Installation Manual*.

These settings are mergeable. Changes to these settings do not require a reboot of the system.

Field	Description
<b>Index</b>	<p>Range = 00 to 99 or None.</p> <p>This value is used with personal speed dials set and dialed from M and T-Series phones. The value can be changed but each value can only be applied to one directory record at any time. Setting the value to <b>None</b> makes the speed dial inaccessible from M and T-Series phones, however it may still be accessible from the directory functions of other phones and applications. The Speed Dial short code feature can be used to create short codes to dial the number stored with a specific index value. Release 10.0 allows users to have up to 250 personal directory entries. However, only 100 of those can be assigned index numbers.</p>
<b>Name</b>	<p>Range = Up to 31 characters.</p> <p>Enter the text to be used to identify the number.</p>
<b>Number</b>	<p>Range = Up to 31 digits plus * and #. Enter the number, without spaces, to be dialed. Wildcards are not supported in user personal directory records. Note that if the system has been configured to use an external dialing prefix, that prefix should be added to directory numbers.</p>

**Related links**

[User](#) on page 413

## Web Self Administration

Navigation: **User | Web Self Administration**

Use this page to enable self-administration for each user. It is used to configure whether they can use self-administration and what features they can access within the self-administration menus.

For a description of the configuration fields available to the user, open the help from the Self Administration user interface or see the document *Avaya IP Office™ Platform Web Self Administration*.

These settings are mergeable. Changes to these settings do not require a reboot of the system.

Name	Description
<b>Enable Self-Administration</b>	<p>Default = Off</p> <p>When enabled, the user can log into web self-administration by entering the address of the system in the format <code>http://&lt;address&gt;</code> and then selecting <b>IP Office Self-Administration</b>. The login uses the user's <b>Name</b> and <b>Password</b>.</p>

*Table continues...*

Name	Description
<b>User Interface</b>	<p>Default = None selected.</p> <p>These options control the options that the user can access within self-administration and the type of access they have. For each set of options, the user can be given read-only access (<b>Visible</b>) or read/write access (<b>Write</b>).</p> <p>The options are:</p> <ul style="list-style-type: none"> <li>• <b>User</b> – This option allows the user to view and change general settings such as their full name and user password.</li> <li>• <b>Voicemail</b> – This option allows the user to view and change their voicemail settings.</li> <li>• <b>DND</b> – This option allows the user to turn DND on/off and to edit their DND exception numbers.</li> <li>• <b>Forwarding</b> – This option allows the user to view and change their call forwarding settings.</li> <li>• <b>Mobility</b> – This option allows the user to view and change their mobile twinning settings.</li> <li>• <b>Personal Directory</b> – This option allows the user to view and edit their personal directory contacts.</li> <li>• <b>Button Programming</b> – This option allows the user to assign features to programmable buttons on their phone and to change button labels. They still cannot override the settings of appearance buttons and buttons set by user rights.</li> <li>• <b>Download Applications</b> – This option display a menu of links for user applications that work with IP Office. Note that the user may require further configuration to use a specific application.</li> </ul>

*Table continues...*

Name	Description
<b>Enable Media Manager Replay</b>	<p>Default = Off.</p> <p>When enabled, the user can replay recordings through web self-administration.</p> <ul style="list-style-type: none"> <li>• <b>Note;</b> For users where is provided by a separate application server, recordings and viewed and accessed using the address of the application server rather than that of the system.</li> </ul> <p>The configuration settings are used to set which recordings the user can view and play:</p> <ul style="list-style-type: none"> <li>• <b>Replay All Recordings</b> – If selected, the user can view and replay all recordings.</li> <li>• <b>Replay Own Recordings</b> – If selected, the user can view and replay their own call recordings.</li> <li>• <b>Download Recordings</b> – If selected, the user is able to download recordings as a separate file. <ul style="list-style-type: none"> <li>- Downloaded files are outside of the control of the system. Therefore, if you allow users to download files, it is your responsibility to ensure that they comply with local privacy and data protection laws regarding the use of those files.</li> </ul> </li> <li>• <b>Replay Recordings For Group</b> – These menus allows the selection of groups for which the user is able to view and replay recordings.</li> <li>• <b>Replay Recordings For Others</b> – The field can be used to enter a list of numbers, separated by semi-colons, for which the user can view and playback recordings. Those numbers can be accounts codes, line numbers, user extensions and group extension numbers. The list can be 127 characters in length.</li> </ul>

**Related links**

[User](#) on page 413

## Group

### Additional configuration information

This section provides the **Group** field descriptions. For additional configuration information, see [Group Operation](#) on page 705.

**Related links**

[Configuration Mode Field Descriptions](#) on page 197

[Group](#) on page 465

[Queuing](#) on page 470

[Overflow](#) on page 473

[Fallback](#) on page 475



[Group | Voicemail](#) on page 478

[Voice Recording](#) on page 483

[Announcements](#) on page 484

[SIP](#) on page 487

## Group

Navigation: **Group | Group**

### Additional configuration information

This type of configuration record can be saved as a template and new records created from a template. See [Working with Templates](#) on page 600.



### Configuration settings

The Group settings are used to define the name, extension number and basic operation of the group. It is also used to select the group members.

These settings are mergeable. Changes to these settings do not require a reboot of the system.

Field	Description
<b>Name</b>	<p>Range = Up to 15 characters</p> <p>The name to identify this group. This field is case sensitive and must be unique.</p> <p>Names should not start with a space. Do not use punctuation characters such as #, ?, /, ^, &gt; and ,.</p> <p>Voicemail uses the name to match a group and its mailbox. Changing a group's name will route its voicemail calls to a new mailbox. Note however that Voicemail Pro will treat names such as "Sales", "sales" and "SALES" as being the same.</p>

*Table continues...*

Field	Description
<p><b>Profile</b></p>	<p>Default = Standard Hunt Group</p> <p>Defines the group type. The options are:</p> <ul style="list-style-type: none"> <li>• <b>Standard Hunt Group:</b> The default group type and the standard method for creating IP Office user groups.</li> <li>• <b>ICR Agent Group:</b> The ICR Agent Group is available as a hunt group in the Profile drop-down menu if Integrated Contact Reporter is selected as a Contact Center Application at <b>System &gt; Contact Center</b> . All the three ring modes, that is, Sequential, Rotary, and Longest waiting are supported with the hunt group configuration. Queuing is supported with all Integrated Contact Reporter hunt groups.</li> </ul> <p> <b>Note:</b></p> <p style="padding-left: 20px;">Integrated Contact Reporter is not supported in IP Office Release 11.0.</p> <ul style="list-style-type: none"> <li>• <b>XMPP Group:</b> Extensible Messaging and Presence Protocol (XMPP) is a communications protocol for presence status and Instant Messaging (IM). Select XMPP to enable presence information and instant messaging within a defined group of XMPP enabled one-X clients. Two users can see each other's presence and exchange instant messages only if they are members of the same XMPP group. A user can be a member of zero or more groups.</li> </ul> <p> <b>Important:</b></p> <p style="padding-left: 20px;">Before adding a user to an XMPP group, the user must be added to the configuration and the configuration saved. If the user is added to the group before the directory is synchronized, the user will not be visible in one-X Portal.</p> <ul style="list-style-type: none"> <li>• <b>Centralized Group:</b> Select Centralized Group for extensions that are normally handled by the core feature server (Avaya Aura Communication Manager) and are handled by the IP Office only when in survival mode due to loss of connection to the Avaya Aura<sup>®</sup> Session Manager. Calls arriving to a centralized hunt group number when the Avaya Aura Session Manager line is in-service are sent by the IP Office&gt; to Avaya Aura Session Manager and are then processed by the core feature server according to the core feature server hunt group configuration. Calls arriving to a centralized hunt group number when the Avaya Aura Session Manager line is out-of-service are processed by the IP Office and targeted to the hunt group members as configured on the IP Office.</li> </ul> <p>To provide consistent operation when the Avaya Aura Session Manager line is in-service or out-of-service, the following is recommended:</p> <ul style="list-style-type: none"> <li>- The IP Office hunt group should be configured consistently with the hunt group administration at the core feature server that serves the survivable branch endpoints in normal mode.</li> <li>- Members included in the IP Office hunt group should be only those members that are in the local branch, even if the core feature server hunt group includes additional members from other branches (that is, centralized users).</li> </ul>

*Table continues...*

Field	Description
<b>Extension</b>	<p>Range = 1 to 15 digits.</p> <p>This sets the directory number for calls to the hunt group.</p> <ul style="list-style-type: none"> <li>• Groups for CBC and CCC should only use up to 4 digit extension numbers.</li> <li>• Extension numbers in the range 8897 to 9999 are reserved for use by the IP Office Delta Server.</li> </ul>
<b>Exclude From Directory</b>	<p>Default = Off</p> <p>When on, the user does not appear in the directory list shown by the user applications and on phones with a directory function.</p>
<b>Ring Mode</b>	<p>Default = Sequential</p> <p>Sets how the system determines which hunt group member to ring first and the next hunt group member to ring if unanswered. This is used in conjunction with the <b>User List</b> which list the order of group membership. The options are:</p> <ul style="list-style-type: none"> <li>• <b>Collective</b> All available phones in the <b>User List</b> phones ring simultaneously. Although DECT handsets can be programmed as members of groups and receive calls in the same manner as any other extension within that group, you must not configure DECT handsets into collective groups.</li> <li>• <b>Collective Call Waiting</b> This is a <b>Collective</b> hunt group as above but with hunt group call waiting also enabled (previous versions of Manager used a separate <b>Call Waiting On</b> control to select this option for a <b>Collective</b> group). When an additional call to the hunt group call is waiting to be answered, users in the group who are already on a call will receive call waiting indication. On phones with call appearance buttons, the call waiting indication takes the form of an alert on the next available call appearance button. On other phones, call waiting indication is given by a tone in the speech path (the tone is locale specific).  The user's own <b>Call Waiting On</b> setting is overridden when they are using a phone with call appearances. Otherwise the user's <b>Call Waiting On</b> setting is used in conjunction with the hunt group setting.</li> <li>• <b>Sequential</b> Each extension is rung in order, one after the other, starting from the first extension in the list each time.</li> <li>• <b>Rotary</b> Each extension is rung in order, one after the other. However, the last extension used is remembered. The next call received rings the next extension in the list.</li> <li>• <b>Longest Waiting</b> The extension that has been unused for the longest period rings first, then the extension that has been idle second longest rings, etc. For extensions with equal idle time, 'sequential' mode is used.</li> </ul> <p>Where hunt group calls are being presented to a twinned extension, the longest waiting status of the user can be reset by calls answered at either their master or twinned extension.</p>

*Table continues...*

Field	Description
<b>No Answer Time (secs)</b>	<p>Default = System Default. Range = System Default or 6 to 99999 seconds.</p> <p>The number of seconds an extension rings before the call is passed to another extension in the list. This applies to all telephones in this group and also any Overflow Groups it uses. For collective hunt groups, the idea of moving to the next member when the <b>No Answer Time</b> expires does not apply, instead calls will continue ringing unless overflow or voicemail is applied.</p>
<b>Hold Music Source</b>	<p>Default = No Change.</p> <p>The system can support multiple music on hold sources; the <b>System Source</b> (either an internal file or the external source port or tones) plus a number of additional internal sources (3 on IP500 V2 systems, 31 on Linux systems), see System   Telephony   Tones &amp; Music. Before reaching a hunt group, the source used is set by the system wide setting or by the Incoming Call Route that routed the call. If the system has several hold music sources available, this field allows selection of the source to associate with calls presented to this hunt group or to leave it unchanged. The new source selection will then apply even if the call is forwarded or transferred out of the hunt group unless changed again by another hunt group. If the call is routed to another system in a multi-site network, the matching source on that system is used if available.</p> <p>Calls overflowing from a hunt group will use the hold music source setting of the original hunt group and ignore the setting of the overflow group.</p> <p>Calls going to night service or out of service fallback group use the hold music source setting of the original hunt group and then, if different, the setting of the fallback group. The setting of further fallback groups from the first are ignored.</p>
<b>Ring Tone Override</b>	<p>Default = Blank</p> <p>If ring tones have been configured in the <b>System   Telephony   Ring Tones</b> tab, they are available in this list. Setting a ring tone override applies a unique ring tone for the hunt group. Ring tone override features are only supported on 1400 Series, 9500 Series and J100 Series (except J129) phones.</p>
<b>Agent's Status on No-Answer Applies To</b>	<p>Default = None (No status change).</p> <p>For call center agents, that is hunt group members with a log in code and set to forced log in, the system can change the agent's status if they do not answer a hunt group call presented to them before being automatically presented to the next available agent.</p> <ul style="list-style-type: none"> <li>• This setting defines what type of hunt group calls should trigger use of the agent's <b>Status on No Answer</b> setting. The options are <b>None</b>, <b>Any Call</b> and <b>External Inbound Calls Only</b>.</li> <li>• The new status is set by the agent's Status on No Answer (User   Telephony   Supervisor Settings) setting.</li> <li>• This action is only applied if the call is unanswered at the agent for the hunt group's <b>No Answer Time</b> or longer. It does not apply if the call is presented and, before the <b>No Answer Time</b> expires, is answered elsewhere or the caller disconnects.</li> <li>• This option is not used for calls ringing the agent because the agent is in another group's overflow group.</li> </ul>

Table continues...

Field	Description
<b>User List</b>	<p>This is an ordered list of the users who are members of the hunt group. For <b>Sequential</b> and <b>Rotary</b> groups it also sets the order in which group members are used for call presentation.</p> <ul style="list-style-type: none"> <li>• Repeated numbers can be used, for example 201, 202, 201, 203, etc. Each extension will ring for the number of seconds defined by the <b>No Answer Time</b> before moving to the next extension in the list, dependent on the Hunt Type chosen.</li> <li>• The check box next to each member indicates the status of their membership. Group calls are not presented to members who have their membership currently disabled. However, those users are still able to perform group functions such as group call pickup.</li> <li>• The order of the users can be changed by dragging the existing records to the required position.</li> <li>• To add records select <b>Edit</b>. A new menu is displayed that shows available users on the left and current group members of the right. The lists can be sorted and filtered.</li> <li>• Users on remote systems in a multi-site network can also be included. Groups containing remote members are automatically advertised within the network.</li> <li>• Before adding a user to an XMPP group, the user must be added to the configuration and the configuration saved. If the user is added to the group before the directory is synchronized, the user will not be visible in one-X Portal.</li> </ul>

### Related links

[Group](#) on page 464

[User List Select Members](#) on page 469

## User List Select Members

Navigation: **Group** | **Group** | **Edit**

To open the Select Memembers window, click **Edit**.

The hunt group **Select Members** form is used to add and remove users from the hunt group. For hunt group's with a **Ring Mode** of **Sequential** or **Rotary** it is also used to set the order of use for the members of the hunt group.

The filters section at the top of the form can be used to filter the users shown. Note for hunt groups set as a **CCR Agent Group**, only users set as **CCR Agent** are shown.

The controls and data on the form vary depending on the hunt group's **Ring Mode** setting and on whether the system is in a multi-site network.

To sort either table, click on the column header that should be used for the sort the table. Sort changes the order of display only, it does not change the actual order of hunt group membership.

For **Sequential** and **Rotary** hunt groups, an **Order** column is shown. To change the order position of a hunt group member, select the member and then use the ↑ up and down ↓ arrow buttons.

During the actions below, the Shift and Ctrl keys can be used as normal to select multiple users. Note that the list of members has been sorted, the sort is updated after adding or moving members.

- **Add Before** Using the Shift and/or Ctrl keys, select the users you want to add and then on the right select the existing member that you want to add them before.
- **Add After** Using the Shift and/or Ctrl keys, select the users you want to add and then on the left select the existing member after which you want them added.
- **Append** Add the selected users on the left to the hunt group members on the right as the last member in the group order.
- **Remove** Remove the selected users on the right from the list of hunt group members.
- **↑ ↓** Move the selected member on the right up or down the membership order of the group.

### Related links

[Group](#) on page 465

---

## Queuing

Navigation: **Group | Queuing**

Any calls waiting to be answered at a hunt group are regarded as being queued. The **Normalise Queue Length** control allows selection of whether features that are triggered by the queue length should include or exclude ringing calls. Once one call is queued, any further calls are also queued. When an available hunt group member becomes idle, the first call in the queue is presented. Calls are added to the queue until the hunt group's Queue Limit, if set, is reached.

- When the queue limit is reached, any further calls are redirected to the hunt group's voicemail if available.
- If voicemail is not available excess calls receive busy tone. An exception to this are analog trunk and T1 CAS trunk calls which will remain queued regardless of the queue limit if no alternate destination is available.
- If an existing queued call is displaced by a higher priority call, the displaced call will remain queued even if it now exceeds the queue limit.

Hunt group announcements are separate from queuing. Announcements can be used even if queuing is turned off and are applied to ringing and queued calls. See Hunt Group | Announcements.

There are several methods of displaying a hunt group queue.

- **Group Button:** On phones, with programmable buttons, the **Group** function can be assigned to monitor a specified group. The button indicates when there are calls ringing within the group and also when there are calls queued. The button can be used to answer the longest waiting call.
- **SoftConsole:** The SoftConsole applications can display queue monitors for up to 7 selected hunt groups. This requires the hunt group to have queuing enabled. These queues can be used by the SoftConsole user to answer calls.

When a hunt group member becomes available, the first call in the queue is presented to that member. If several members become available, the first call in the queue is simultaneously presented to all the free members.

**Overflow Calls** Calls that overflow are counted in the queue of the original hunt group from which they overflow and not that of the hunt group to which they overflow. This affects the **Queue Limit** and **Calls in Queue Threshold**.

These settings are mergeable. Changes to these settings do not require a reboot of the system.

Field	Description
<b>Queuing On</b>	<p>Default = On</p> <p>This settings allows calls to this hunt group to be queued. This option is automatically enabled and cannot be disabled for a CCR agent group.</p>
<b>Queue Length</b>	<p>Default = No Limit. Range = No Limit, 1 to 99 calls.</p> <p>This setting can be used to limit the number of calls that can be queued. Calls exceeding this limit are passed to voicemail if available or otherwise receive busy tone. This value is affected by Normalize Queue Length setting.</p> <ul style="list-style-type: none"> <li>• If voicemail is not available excess calls receive busy tone. An exception to this is analog trunk and T1 CAS trunk calls which will remain queued regardless of the queue limit if no alternate destination is available. This is due to the limited call status signalling supported by those trunks which would otherwise create scenarios where the caller has received ringing from the local line provider and then suddenly gets busy from the system, creating the impression that the call was answered and then hung up.</li> <li>• If priority is being used with incoming call routes, high priority calls are place ahead of lower priority calls. If this would exceed the queue limit the limit is temporarily increased by 1.</li> <li>• If an existing queued call is displaced by a higher priority call, the displaced call will remain queued even if it now exceeds the queue limit.</li> </ul>
<b>Normalize Queue Length</b>	<p>Default = On.</p> <p>Calls both waiting to ring and ringing are regarded as being queued. This therefore affects the use of the <b>Queue Limit</b> and <b>Calls in Queue Alarm</b> thresholds. If <b>Normalize Queue Length</b> is enabled, the number of hunt group members logged in and not on DND is added to those thresholds.</p> <p>For example, a customer has two products that it is selling through a call center with 10 available agents; one product with a \$10 margin and one with a \$100 margin. Separate hunt groups with the same 10 members are created for each product.</p> <ul style="list-style-type: none"> <li>• The \$100 product has a Queue Limit of 5 and Normalize Queue Length is on. The maximum number of \$100 calls that can be waiting to be answered will be 15 (10 ringing/connected + 5 waiting to ring).</li> <li>• The \$10 product has a Queue Limit of 5 and Normalize Queue Length is off. The maximum number of \$10 calls that can be waiting to be answered is 5 (5 ringing/connected).</li> </ul>

*Table continues...*

Field	Description
<b>Queue Type</b>	<p>Default = Assign Call On Agent Answer.</p> <p>When queuing is being used, the call that the agent receives when they answer can be assigned in one of two ways:</p> <ul style="list-style-type: none"> <li>• <b>Assign Call On Agent Answer</b> In this mode the call answered by the hunt group member will always be the longest waiting call of the highest priority. The same call will be shown on all ringing phones in the group. At the moment of answering that may not necessarily be the same call as was shown by the call details at the start of ringing.</li> <li>• <b>Assign Call on Agent Alert</b> In this mode, once a call has been presented to a hunt group member, that is the call they will answer if they go off hook. This mode should be used when calls are being presented to applications which use the call details such as a fax server, CTI or TAPI.</li> </ul>
<b>Calls In Queue Alarm</b>	The system can be set to send an alert to a analog specified extension when the number of calls queued for the hunt group reaches the specified threshold.
<b>Calls In Queue Threshold</b>	<p>Default = Off. Range = 1 to 99.</p> <p>Alerting is triggered when the number of queued calls reaches this threshold. Alerting will stop only when the number of queued calls drops back below this threshold. This value is affected by <b>Normalize Queue Length</b> setting above.</p>
<b>Analog Extension to Notify</b>	<p>Default = &lt;None&gt;.</p> <p>This should be set to the extension number of a user associated with an analog extension. The intention is that this analog extension port should be connected to a loud ringer or other alerting device and so is not used for making or receiving calls. The list will only show analog extensions that are not members of any hunt group or the queuing alarm target for any other hunt group queue. The alert does not follow user settings such as forwarding, follow me, DND, call coverage, etc or receive ICLID information.</p>

### Group Queue Controls

Group Queue Settings	
<b>Manager</b>	Hunt group queuing is enabled using the Queuing On option on the <b>Hunt Group   Queuing</b> tab.
<b>Controls</b>	The following short code features/button programming actions can be used:
<b>SoftConsole</b>	<p>SoftConsole can display up to 7 hunt group queues (an eight queue is reserved for recall calls). They are configured by clicking  and selecting the Queue Mode tab. For each queue alarm threshold can be set based on number of queued calls and longest queued call time. Actions can then be selected for when a queue exceeds its alarm threshold; <b>Automatically Restore SoftConsole, Ask me whether to restore SoftConsole or Ignore the Alarm.</b></p> <p>Within the displayed queues, the number of queued calls is indicated and the time of the longest queued call is shown. Exceeding an alarm threshold is indicated by the queue icons changing from white to red. The longest waiting call in a queue can be answered by clicking on the adjacent button.</p>



## Related links

[Group](#) on page 464

---

# Overflow

Navigation: **Group | Overflow**

Overflow can be used to expand the list of group members who can be used to answer a call. This is done by defining an overflow group or groups. The call is still targeted to the original group and subject to that group's settings, but is now presented to available members in the overflow groups in addition to its own available members.

Overflow calls still use the settings of the original target group. The only settings of the overflow group that is used is its **Ring Mode**. For example:

- Calls that overflow use the announcement settings of the group from which they are overflowing.
- Calls that overflow use the **Voicemail Answer Time** of the original group from which are are overflowing.
- Calls that are overflowing are included in the overflowing group's **Queue Length** and **Calls In Queue Threshold**. They are not included in those values for the hunt group to which they overflow.
- The queuing and overflow settings of the overflow groups are not used, ie. calls cannot cascade through a series of multiple overflows.

A call will overflow in the following scenarios:

- If **Queuing** is off and all members of the hunt group are busy, a call presented to the group will overflow immediately, irrespective of the **Overflow Time**.
- If **Queuing** is on and all members of the hunt group are busy, a call presented to the group will queue for up to the **Overflow Time** before overflowing.
- If **Queuing** is on but there are no members logged in or enabled, calls can be set to overflow immediately by setting the **Overflow Immediate** setting to **No Active Members**. Otherwise calls will queue until the **Overflow Time** expires.
- If no **Overflow Time** is set, a call will overflow when it has rung each available hunt group member without being answered.
- Once one call is in overflow mode, any additional calls will also overflow if the **Overflow Mode** is set to **Group** (the default).

An overflow call is presented to available group members as follows:

- Once a call overflows, it is presented to the first available member of the first overflow group listed. The **Ring Mode** of the overflow group is used to determine its first available member. However the **No Answer Time** of the original targeted group is used to determine how long the call is presented.
- When the **No Answer Time** expires, the call is presented to the next available member in the overflow group. If all available members in the overflow group have been tried, the first member in the next listed overflow group is tried.

- When the call has been presented to all available members in the overflow groups, it is presented back to the first available member in the original target group.
- While the call is being presented to members in an overflow group, the announcement and voicemail settings of the original targeted group are still applied.

For calls being tracked by the Customer Call Reporter application, overflow calls are recorded against the original targeted group but using separate statistics; **Overflowed Calls**, **Overflowed Calls Waiting**, **Overflowed Answered** and **Overflowed Lost**.

These settings are mergeable. Changes to these settings do not require a reboot of the system.

Field	Description
<b>Overflow Time</b>	<p>Default = Blank. Range = Off or 1 to 3600 seconds.</p> <p>For a group using queuing, the <b>Overflow Time</b> sets how long a call queues before being presented to available agents in the group's <b>Overflow Group List</b>. Note that if the call is currently ringing an agent when the timer expires, it will complete ringing for the group's <b>No Answer Time</b> before overflowing.</p>
<b>Overflow Mode</b>	<p>Default = Group.</p> <p>This option allows selection of whether the overflow of queued calls is determined on an individual call by call basis or is applied to all calls once any one call overflows. The options are:</p> <ul style="list-style-type: none"> <li>• <b>Group</b>: In this mode, once one call overflows all additional queued calls also overflow.</li> <li>• <b>Call</b>: In this mode, each individual call will follow the group's overflow settings before it overflows.</li> </ul>
<b>Immediate Overflow:</b>	<p>Default = Off.</p> <p>For groups which are using queueing, this setting can be used to control whether calls should overflow immediately when there are no available or active agents. The options are:</p> <ul style="list-style-type: none"> <li>• <b>Off</b>: Do not overflow immediately. Use the <b>Overflow Time</b> setting as normal.</li> <li>• <b>No Active Agents</b>: Overflow immediately if there are no available or active agents as defined above, regardless of the <b>Overflow Time</b> setting. <ul style="list-style-type: none"> <li>- An active agent is an agent who is either busy on a call or in after call work. An available agent is one who is logged in and enabled in the hunt group but is otherwise idle.</li> <li>- A hunt group is automatically treated as having no available or active agents if: <ul style="list-style-type: none"> <li>- The group's extension list is empty.</li> <li>- The group's extension list contains no enabled users.</li> <li>- The group's extension list contains no extensions that resolve to a logged in agent (or mobile twin in the case of a user logged out mobile twinning).</li> </ul> </li> </ul> </li> </ul>

*Table continues...*

Field	Description
<b>Overflow Group List</b>	This list is used to set the group or groups that are used for overflow. Each group is used in turn, in order from the top of the list. The call is presented to each overflow group member once, using the <b>Ring Mode</b> of the overflow group. If the call remains unanswered, the next overflow group in the list is used. If the call remains unanswered at the end of the list of overflow groups, it is presented to available members of the original targeted group again and then to those in its overflow list in a repeating loop. A group can be included in the overflow list more than once if required and the same agent can be in multiple groups.

## Related links

[Group](#) on page 464

## Fallback

Navigation: **Group | Fallback**

Fallback settings can be used to make a hunt group unavailable and to set where the hunt group's calls should be redirected at such times. Hunt groups can be manually placed In Service, Out of Service or in Night Service. Additionally using a time profile, a group can be automatically placed in Night Service when outside the Time Profile settings.

Fallback redirects a hunt group's calls when the hunt group is not available, for example outside normal working hours. It can be triggered either manually or using an associated time profile.

### Group Service States:

A hunt group can be in one of three states; **In Service**, **Out of Service** or **Night Service**. When **In Service**, calls are presented as normal. In any other state, calls are redirected as below.



### Call Redirection:

The following options are possible when a hunt group is either **Out of Service** or in **Night Service**.

- **Destination:** When in **Out of Service**, if an **Out of Service Destination** has been set, calls are redirected to that destination. When in **Night Service**, if a **Night Service Destination** has been set, calls are redirected to that destination.
- **Voicemail:** If no fallback destination has been set but voicemail is enabled for the group, calls are redirected to voicemail.
- **Busy Tone:** If no fallback destination has been set and voicemail is not available, busy tone is returned to calls.

### Manually Controlling the Service State:

Manager and or short codes can be used to change the service state of a hunt group. The short code actions can also be assigned to programmable buttons on phones.

- The  icon is used for a hunt group manually set to **Night Service** mode.
- The  icon is used for a hunt group manually set to **Out of Service** mode.

Setting and clearing hunt group night service can be done using either manual controls or using a system time profile. The use of both methods to control the night service status of a particular hunt group is not supported. You can manually override a time profile.

**Time Profile:**

A **Day Service Time Profile** can be associated with the hunt group. A time profile if required, is set through **Time Profile | Time Profile**.

When outside the time profile, the hunt group is automatically placed into night service. When inside the time profile, the hunt group uses manually selected mode.

- When outside the time profile and therefore in night service, manual night service controls cannot be used to override the night service. However the hunt group can be put into out of service.
- When a hunt group is in Night Service due to a time profile, this is not indicated within Manager.
- Time profile operation does not affect hunt groups set to Out of Service.

These settings are mergeable. Changes to these settings do not require a reboot of the system.

Field	Description
<b>Day Service Time Profile</b>	Default = <None> (No automatic night service)  This field allows selection of a previously created Time Profile. That profile then specifies the times at which it should use the manually selected Service Mode settings. Outside the period defined in the time profile, the hunt group behaves as if set to Night Service mode.  Note that when a hunt group is in Night Service due to it associated time profile, this is not reflected by the Service Mode on this tab. Note also that the manual controls for changing a hunt group's service mode cannot be used to take a hunt group out of time profile night service.
<b>Night Service Destination</b>	Default = <None> (Voicemail or Busy Tone)  This field sets the alternate destination for calls when this hunt group is in Night Service mode. The destination can be a group, a user, a short code, or an Auto Attendant. Select a group or user from the drop down list. Manually enter a short code or an Auto Attendant name.  If left blank, calls are redirected to voicemail if available or otherwise receive busy tone.
<b>Out of Service Fallback Group</b>	Default = <None> (Voicemail or Busy Tone)  This field sets the alternate destination for calls when this hunt group is in Out of Service mode. The destination can be a group, a user, a short code, or an Auto Attendant. Select a group or user from the drop down list. Manually enter a short code or an Auto Attendant name. For Auto Attendant names, use the format <b>AA:Name</b> .  If left blank, calls are redirected to voicemail if available or otherwise receive busy tone.

*Table continues...*

Field	Description
<b>Mode</b>	<p>Default = In Service</p> <p>This field is used to select the current service mode for the hunt group manually. The options are:</p> <ul style="list-style-type: none"> <li>• <b>In Service:</b> When selected, the hunt group is enabled. This is the default mode.</li> <li>• <b>Night Service:</b> When selected, calls are redirected using the <b>Night Service Fallback Group</b> setting. This setting can also be manually controlled using the short code, and button programming features Set Hunt Group Night Service and Clear Hunt Group Night Service.</li> <li>• <b>Out of Service:</b> When selected, calls are redirected using the <b>Out of Service Fallback Group</b> setting. This setting can also be manually controlled using the short code, and button programming features Set Hunt Group Out of Service and Clear Hunt Group Out of Service.</li> </ul>
<b>Group No Answer Time</b>	<p>Default = 45 seconds, Range = 1 to 3600 seconds.</p> <p>This setting sets the time duration on preting a call to a hunt group and its overflow groups if set before going to the group's <b>Group No Answer Destination</b>.</p> <p>Exceeding the time duration redirects the call regardless of any announcements, overflow, or queue. If <b>Group No Answer Time</b> is set to <b>Off</b>, the no answer destination is used, and once each available member of the hunt group is alerted for the group's <b>No Answer Time</b>.</p>
<b>Group No Answer Destination</b>	<p>When an unanswered call to a hunt group reaches the <b>Group No Answer Time</b>, you can configure the following options:</p> <ul style="list-style-type: none"> <li>• <b>&lt;NONE&gt;</b> - The destination is not used. Instead, calls continue ringing against the hunt group.</li> <li>• <b>Voicemail</b> - The call is redirected to a voicemail to leave a message and uses the call original destination mailbox. Set to <b>Voicemail</b> for default configurations.</li> <li>• The drop-down list includes all other group and user extensions and redirects the call to that extension.</li> <li>• You can enter a number manually to match against system short codes.</li> </ul>

## Hunt Group Fallback Controls

The following short code features and button programming actions can be used.

Feature/Action	Short Code	Default	Button
Set Hunt Group Night Service	Yes	*20*N#	Yes-Toggles
Clear Hunt Group Night Service	Yes	*21*N#	Yes
Set Hunt Group Out of Service	No	No	Yes-Toggles
Clear Hunt Group Out of Service	No	No	Yes

Note that for a hunt group using a time profile, these controls only are only applied when the hunt group is within the specified time profile period. When outside its time profile, the hunt group is in night service mode and cannot be overridden.

### Related links

[Group](#) on page 464

---

## Group | Voicemail

Navigation: **Group | Voicemail**

The system supports voicemail for hunt groups in addition to individual user voicemail mailboxes.

If voicemail is available and enabled for a hunt group, it is used in the following scenarios.

- **Group No Answer Time** : For 11.1 FP1 and higher, the use of voicemail to answer calls during normal operation is controlled by the group's Fallback settings.
- **Voicemail Answer Time**: This option is only used for pre-11.1 FP1 systems. A call goes to voicemail when this timeout is reached, regardless of any announcement, overflow, queuing or other settings. The default timeout is 45 seconds.
- **Unanswered Calls**: A call goes to voicemail when it has been presented to all the available hunt group members without being answered. If overflow is being used, this includes be presented to all the available overflow group members.
- **Night Service**: A call goes to voicemail if the hunt group is in night service with no **Night Service Fallback Group** set.
- **Out of Service**: A call goes to voicemail if the hunt group is out of service with no **Out of Service Fallback Group** set.
- **Queue Limit Reached**: If queuing is being used, it overrides use of voicemail prior to expiry of the **Voicemail Answer Time**, unless the number of queued callers exceeds the set **Queue Limit**. By default there is no set limit.
- **Automatic Call Recording**: Incoming calls to a hunt group can be automatically recorded using the settings on the **Hunt Group > Voice Recording tab**.

When a caller is directed to voicemail to leave a message, the system indicates the target user or hunt group mailbox.

The mailbox of the originally targeted user or hunt group is used. This applies even if the call has been forwarded to another destination. It also includes scenarios where a hunt group call overflows or is in fallback to another group.

Voicemail Pro can be used to customize which mailbox is used separately from the mailbox indicated by the system.



By default no user is configured to receive message waiting indication when a hunt group voicemail mailbox contains new messages. Message waiting indication is configured by adding a **H groupname** record to a user's **SourceNumbers** tab (**User > Source Numbers**).

By default, no mechanism is provided for access to specific hunt group mailboxes. Access needs to be configured using either a short code, programmable button or source number.

- **Intuity Emulation Mailbox Mode:** For systems using Intuity emulation mode mailboxes, the hunt group extension number and voicemail code can be used during normal mailbox access.
- **Avaya Branch Gateway Mailbox Mode or IP Office Mailbox Mode:** For this mode of mailbox access, short codes or a Voicemail Collect button are required to access the mailbox directly.

The voicemail system (Voicemail Pro only) can be instructed to automatically forward messages to the individual mailboxes of the hunt group members. The messages are not stored in the hunt group mailbox.

These settings are mergeable. Changes to these settings do not require a reboot of the system.

Field	Description
<b>Voicemail On</b>	<p> <b>Note:</b></p> <p>From 11.1 FP1 IP Office system onwards, you can configure <b>Voicemail On</b> through <b>Group No Answer Destination</b> under <b>Group   Fallback</b> tab.</p> <p>Default = On</p> <p>When on, the mailbox is used by the system to answer the any calls to the group that reaches the <b>Voicemail Answer Time</b>. Note that selecting off does not disable the use of the group mailbox. Messages can still be forward to the mailbox, and recordings can be placed in it. The mailbox can also still be accessed to collect messages.</p> <p>When a caller is directed to the voicemail to leave a message, the system indicates the target user or hunt group mailbox.</p> <ul style="list-style-type: none"> <li>• The mailbox of the originally targeted user or hunt group is used. This applies even if the call was forwarded to another destination. It also includes scenarios where a hunt group call overflows or is in fallback to another group.</li> <li>• Voicemail Pro can be used to customize which mailbox is used separately from the mailbox indicated by the system.</li> </ul>
<b>Voicemail Answer Time</b>	<p> <b>Note:</b></p> <p>From 11.1 FP1 IP Office system onwards, you can configure <b>Voicemail Answer Time</b> through <b>Group No Answer Time</b> under <b>Group   Fallback</b> tab.</p> <p>Default = 45 seconds. Range = Off, 1 to 99999 seconds.</p> <p>This setting sets how long a call should be presented to a hunt group, and its overflow groups if set, before going to the voicemail. When exceeded, the call goes to voicemail (if available) regardless of any announcements, overflow, queuing, or any other actions. If set to <b>Off</b>, voicemail is used when all available members of the hunt group have been alerted for the no answer time.</p>

*Table continues...*

Field	Description
<p><b>Voicemail Code</b></p>	<p>Default = Blank. Range = 0 (no code) to 15 digits.</p> <p>A code used by the voicemail server to validate access to this mailbox. If remote access is attempted to a mailbox that has no voicemail code set, the prompt "Remote access is not configured on this mailbox" is played.</p> <p>The mailbox access code can be set through IP Office Manager or through the mailbox telephone user interface (TUI). The minimum password length is:</p> <ul style="list-style-type: none"> <li>• Voicemail Pro (Manager) - 0</li> <li>• Voicemail Pro (Intuity TUI) - 2</li> <li>• Embedded Voicemail (Manager) - 0</li> <li>• Embedded Voicemail (Intuity TUI) - 0</li> </ul> <p>Codes set through the Voicemail Pro telephone user interface are restricted to valid sequences. For example, attempting to enter a code that matches the mailbox extension, repeat the same number (1111) or a sequence of numbers (1234) are not allowed. If these types of code are required they can be entered through Manager.</p> <p>Manager does not enforce any password requirements for the code if one is set through Manager.</p> <ul style="list-style-type: none"> <li>• <b>Embedded Voicemail</b> For Embedded Voicemail running in IP Office mailbox mode, the voicemail code is used if set.</li> <li>• <b>IP Office mode</b> The voicemail code is required when accessing the mailbox from a location that is not set as a trusted number in the user's Source Numbers list.</li> <li>• <b>Intuity Emulation mode</b> By default the voicemail code is required for all mailbox access. The first time the mailbox is accessed the user will be prompted to change the password. Also if the voicemail code setting is left blank, the caller will be prompted to set a code when they next access the mailbox. The requirement to enter the voicemail code can be removed by adding a customized user or default collect call flow, refer to the Voicemail Pro manuals for full details.</li> <li>• <b>Trusted Source Access</b> The voicemail code is required when accessing the mailbox from a location that is not set as a trusted number in the user's Source Numbers list.</li> <li>• <b>Call Flow Password Request</b> Voicemail Pro call flows containing an action where the action's PIN code set to \$ will prompt the user for their voicemail code.</li> </ul>
<p><b>Voicemail Help</b></p>	<p>Default = Off</p> <p>This option controls whether users retrieving messages are automatically given an additional prompt "For help at any time press 8." If switched off, users can still press 8 for help. For voicemail systems running in Intuity emulation mode, this option has no effect. On those systems the default access greeting always includes the prompt "For help at any time, press *4" (*H in the US locale).</p>

*Table continues...*



Field	Description
<b>Broadcast</b>	<p>Default = Off. (Voicemail Pro only).</p> <p>When enabled, if a voicemail message is left for the hunt group, copies of the message are forwarded to the mailboxes of the individual group members. The original message in the hunt group mailbox is deleted unless it occurred as the result of call recording. This feature is not applied to recordings created by <b>Voice Question</b> actions.</p>
<b>UMS Web Services</b>	<p>Default = Off.</p> <p>This option is used with Voicemail Pro. If enabled, the hunt group mailbox can be accessed using either an IMAP email client or a web browser. Note that the mailbox must have a voicemail code set in order to use either of the UMS interfaces. <b>UMS Web Service</b> licenses are required for the number of groups configured.</p> <p>In the License section, double-clicking on the <b>UMS Web Services</b> license display a menu that allows you to add and remove users and groups from the list of those enabled for UMS Web Services without having to open the settings of each individual user or group.</p>
<b>Voicemail Email:</b>	<p>Default = Blank (No voicemail email features)</p> <p>This field is used to set the user or group email address used by the voicemail server for voicemail email operation. When an address is entered, the additional Voicemail Email control below are selectable to configure the type of voicemail email service that should be provided.</p> <p>Use of voicemail email requires the Voicemail Pro server to have been configured to use either a local MAPI email client or an SMTP email server account. For Embedded Voicemail, voicemail email is supported and uses the system's SMTP settings.</p> <p>The use of voicemail email for the sending (automatic or manual) of email messages with wav files attached should be considered with care. A one-minute message creates a 1MB .wav file. Many email systems impose limits on emails and email attachment sizes. For example the default limit on an Exchange server is 5MB.</p>

*Table continues...*

Field	Description
<p><b>Voicemail Email</b></p>	<p>Default = Off</p> <p>If an email address is entered for the user or group, the following options become selectable. These control the mode of automatic voicemail email operation provided by the voicemail server whenever the voicemail mailbox receives a new voicemail message.</p> <p>Users can change their voicemail email mode using visual voice. If the voicemail server is set to IP Office mode, user can also change their voicemail email mode through the telephone prompts. The ability to change the voicemail email mode can also be provided by Voicemail Pro in a call flow using a Play Configuration Menu action or a Generic action.</p> <p>If the voicemail server is set to IP Office mode, users can manually forward a message to email.</p> <p>The options are:</p> <ul style="list-style-type: none"> <li>• <b>Off</b> If off, none of the options below are used for automatic voicemail email. Users can also select this mode by dialing *03 from their extension.</li> <li>• <b>Copy</b> If this mode is selected, each time a new voicemail message is received in the voicemail mailbox, a copy of the message is attached to an email and sent to the email address. There is no mailbox synchronization between the email and voicemail mailboxes. For example reading and deletion of the email message does not affect the message in the voicemail mailbox or the message waiting indication provided for that new message.</li> <li>• <b>Forward</b> If this mode is selected, each time a new voicemail message is received in the voicemail mailbox, that message is attached to an email and sent to the email address. No copy of the voicemail message is retained in the voicemail mailbox and there is no message waiting indication. As with Copy, there is no mailbox synchronization between the email and voicemail mailboxes. Users can also select this mode by dialing *01 from their extension.</li> </ul> <p>Note that until email forwarding is completed, the message is present in the voicemail server mailbox and so may trigger features such as message waiting indication.</p> <ul style="list-style-type: none"> <li>• <b>UMS Exchange 2007</b> With Voicemail Pro, the system supports voicemail email to an Exchange 2007 server email account. For users and groups also enabled for UMS Web Services this significantly changes their mailbox operation. The Exchange Server inbox is used as their voicemail message store and features such as message waiting indication are set by new messages in that location rather than the voicemail mailbox on the voicemail server. Telephone access to voicemail messages, including Visual Voice access, is redirected to the Exchange 2007 mailbox.</li> <li>• <b>Alert</b> If this mode is selected, each time a new voicemail message is received in the voicemail mailbox, a simple email message is sent to the email address. This is an email message announcing details of the voicemail message but with no copy of the voicemail message attached. Users can also select this mode by dialing *02 from their extension.</li> </ul>

**Related links**

[Group](#) on page 464

## Voice Recording

Navigation: **Group | Voice Recording**

This tab is used to configure automatic recording of external calls handled by hunt group members. The recording of internal calls as well is also supported.

Call recording requires Voicemail Pro to be installed and running. Call recording also requires available conference resources similar to a 3-way conference.

Note the following:

- Calls to and from IP devices, including those using Direct media, can be recorded.
- Calls parked or held pause recording until the unparked or taken off hold (does not apply to SIP terminals).
- Groups voice recording continues for the duration of the call on the system or up to the maximum recording time configured on the voicemail server.
- Recording is stopped if:
  - User recording stops if the call is transferred to another user.
  - User account code recording stops if the call is transferred to another user.
  - Hunt group recording stops if the call is transferred to another user who is not a member of the hunt group.

A destination mailbox other than the hunt group's own mailbox can be specified as the destination for recordings.

These settings are mergeable. Changes to these settings do not require a reboot of the system.

Field	Description
<b>Record Inbound</b>	Default = None Select whether automatic recording of incoming calls is enabled. The options are: <ul style="list-style-type: none"> <li>• <b>None</b>: Do not automatically record calls.</li> <li>• <b>On</b>: Record the call if possible. If not possible to record, allow the call to continue.</li> <li>• <b>Mandatory</b>: Record the call if possible. If not possible to record, block the call and return busy tone.</li> <li>• <b>Percentages of calls</b>: Record a selected percentages of the calls.</li> </ul>
<b>Record Time Profile</b>	Default = <None> (Any time) Used to select a time profile during which automatic call recording of incoming calls is applied. If no profile is selected, automatic recording of incoming calls is active at all times.

*Table continues...*

Field	Description
<b>Recording (Auto)</b>	<p>Default = Mailbox</p> <p>Sets the destination for automatically triggered recordings. The options are:</p> <ul style="list-style-type: none"> <li>• <b>Mailbox</b> This option sets the destination for the recording to be a selected user or hunt group mailbox. The adjacent drop down list is used to select the mailbox.</li> <li>• <b>Voice Recording Library</b>: This options set the destination for the recording to be a VRL folder on the voicemail server. The ContactStore application polls that folder and collects waiting recordings which it then places in its own archive. Recording is still done by the Voicemail Pro.</li> <li>• <b>Voice Recording Library Authenticated</b>: This option is similar to Voice Recording Library above but instructs the voicemail server to create an authenticated recording. If the file contents are changed, the file is invalidated though it can still be played. This option is currently not supported with Linux based servers.</li> </ul>
<b>Auto Record Calls</b>	<p>Default = External.</p> <p>This setting allows selection of whether <b>External</b> or <b>External &amp; Internal</b> calls are subject to automatic call recording.</p>

### Related links

[Group](#) on page 464

---

## Announcements

Navigation: [Group | Announcements](#)

Announcements are played to callers waiting to be answered. This includes callers being presented to hunt group members, ie. ringing, and callers queued for presentation.

- The system supports announcements using Voicemail Pro or Embedded Voicemail.
- If no voicemail channel is available for an announcement, the announcement is not played.
- In conjunction with Voicemail Pro, the system allows a number of voicemail channels to be reserved for announcements. See **System | Voicemail**.
- With Voicemail Pro, the announcement can be replaced by the action specified in a Queued (1st announcement) or Still Queued (2nd announcement) start point call flow. Refer to the *Voicemail Pro Installation and Maintenance* documentation for details.
- Calls can be answered during the announcement. If it is a mandatory requirement that announcements should be heard before a call is answered, then a Voicemail Pro call flow should be used before the call is presented.

 **Note:**

### Call Billing and Logging

Acall becomes connected when the first announcement is played to it. That connected state is signaled to the call provider who may start billing at that point. The call will also be recorded as answered within the SMDR output once the first announcement is played.

- If a call is rerouted to a hunt group's Night Service Group or Out of Service Fallback Group, the announcements of the new group are applied.
- If a call overflows, the announcements of the original group are still applied, not those of the overflow group.
- For announcements to be used effectively, the hunt group's **Voicemail Answer Time** must be extended or **Voicemail On** must be unselected.

## Recording the Group Announcement

Voicemail Pro provides a default announcement "I'm afraid all the operators are busy but please hold and you will be transferred when somebody becomes available". This default is used for announcement 1 and announcement 2 if no specific hunt group announcement has been recorded. Embedded Voicemail does not provide any default announcement. Voicemail Lite also provides the default announcements.

The maximum length for announcements is 10 minutes. New announcements can be recorded using the following methods.

**Voicemail Lite:** Access the hunt group mailbox and press 3. Then press either 3 to record the 1st announcement for the hunt group or 4 to record the 2nd announcement for the hunt group.

**Voicemail Pro :** The method of recording announcements depends on the mailbox mode being used by the voicemail server.

- **IP Office Mailbox Mode:** Access the hunt group mailbox and press 3. Then press either 3 to record the 1st announcement for the hunt group or 4 to record the 2nd announcement for the hunt group.
- **Intuity Emulation Mailbox Mode:** There is no mechanism within the Intuity telephony user interface (TUI) to record hunt group announcements. To provide custom announcements, hunt group queued and still queued start points must be configured with Voicemail Pro with the required prompts played by a generic action.

**Embedded Voicemail:** Embedded Voicemail does not include any default announcement or method for recording announcements. The Record Message short code feature is provided to allow the recording of announcements. The telephone number field of short codes using this feature requires the extension number followed by either ".1" for announcement 1 or ".2" for announcement 2. For example, for extension number 300, the short codes **\*91N# | Record Message | N".1"** and **\*92N# | Record Message | N".2"** could be used to allow recording of the announcements by dialing **\*91300#** and **\*92300#**.

These settings are mergeable. Changes to these settings do not require a reboot of the system.

Field	Description
<b>Announcements On</b>	Default = Off. This setting enables or disables announcements.
<b>Wait before 1st announcement:</b>	Default = 10 seconds. Range = 0 to 255 seconds. This setting sets the time delay from the calls presentation, after which the first announcement should be played to the caller. If <b>Synchronize Calls</b> is selected, the actual wait may differ, see below.

*Table continues...*

Field	Description
<b>Flag call as answered</b>	<p>Default = Off.</p> <p>This setting is used by the CCC and CBC applications. By default they do not regard a call as answered until it has been answered by a person or by a Voicemail Pro action with <b>Flag call as answered</b> selected. This setting allows calls to be marked as answered once the caller has heard the first announcement.</p>
<b>Post announcement tone</b>	<p>Default = Music on hold.</p> <p>Following the first announcement, you can select whether the caller should hear Music on Hold, <b>Ring</b> or <b>Silence</b> until answered or played another announcement.</p>
<b>2nd Announcement</b>	<p>Default = On.</p> <p>If selected, a second announcement can be played to the caller if they have still not been answered.</p>
<b>Wait before 2nd announcement</b>	<p>Default = 20 seconds. Range = 0 to 255 seconds.</p> <p>This setting sets the wait between the 1st and the 2nd announcement. If <b>Synchronize Calls</b> is selected, the actual wait may differ, see below.</p>
<b>Repeat last announcement</b>	<p>Default = On.</p> <p>If selected, the last announcement played to the caller is repeated until they are answered or hang-up.</p>
<b>Wait before repeat</b>	<p>Default = 20 seconds. Range = 0 to 255 seconds.</p> <p>If <b>Repeat last announcement</b> is selected, this setting sets is applied between each repeat of the last announcement. If <b>Synchronize Calls</b> is selected, this value is grayed out and set to match the <b>Wait before 2nd announcement</b> setting.</p>

*Table continues...*

Field	Description
<b>Synchronize calls</b>	<p>Default = Off</p> <p>This option can be used to restrict how many voicemail channels are required to provide the announcements.</p> <p>When <b>Synchronize</b> calls is off, announcement are played individually for each call. This requires a separate voicemail channel each time an announcement is played to each caller. While this ensures accurate following of the wait settings selected, it does not make efficient use of voicemail channels.</p> <p>When <b>Synchronize calls</b> is on, if a required announcement is already being played to another caller, further callers wait until the announcement been completed and can be restarted. In addition, when a caller has waited for the set wait period and the announcement is started, any other callers waiting for the same announcement hear it even if they have not waited for the wait period. Using this setting, the maximum number of voicemail channels ever needed is 1 or 2 depending on the number of selected announcements.</p> <p> <b>Note:</b></p> <p><b>Interaction with Voicemail Pro Queued and Still Queued Start Points</b> If either custom <b>Queued</b> or <b>Still Queued</b> start point call flows are being used for the announcements, when <b>Synchronize Calls</b> is enabled those call flows will support the playing of prompts only. Voicemail Pro actions such as <b>Speak ETA</b>, <b>Speak Position</b>, <b>Menu</b>, <b>Leave Mail</b>, <b>Transfer</b> and <b>Assisted Transfer</b>, etc. are not supported.</p>

### Related links

[Group](#) on page 464

## SIP

Navigation: **Group | SIP**

Each hunt group can be configured with its own SIP URI information. For calls received on a SIP line where any of the line's SIP URI fields are set to **Use Internal Data**, if the call is presented to the hunt group that data is taken from these settings.

This form is hidden if there are no system multi-site network lines in the configuration or no SIP lines with a URI set to **Use Internal Data**.

These settings are mergeable. Changes to these settings do not require a reboot of the system.

Field	Description
<b>SIP Name:</b>	<p>Default = Blank on Voicemail tab/Extension number on other tabs.</p> <p>The value from this field is used when the From field of the SIP URI being used for a SIP call is set to <b>Use Internal Data</b>.</p>

*Table continues...*

Field	Description
<b>SIP Display Name (Alias)</b>	Default = Blank on Voicemail tab/Name on other tabs. The value from this field is used when the Display Name field of the SIP URI being used for a SIP call is set to <b>Use Internal Data</b> .
<b>Contact</b>	Default = Blank on Voicemail tab/Extension number on other tabs. The value from this field is used when the Contact field of the SIP URI being used for a SIP call is set to <b>Use Internal Data</b> .
<b>Anonymous</b>	Default = On on Voicemail tab/Off on other tabs. If the From field in the SIP URI is set to <b>Use Internal Data</b> , selecting this option inserts <b>Anonymous</b> into that field rather than the SIP Name set above.

**Related links**

[Group](#) on page 464

## Short Code

Navigation: [Short Code](#) | [Short Code](#)

### Additional configuration information

This section provides the Short Code field descriptions. For additional configuration information, see [Short Code Features](#) on page 827.

### Configuration settings

These settings are used to create System Short Codes. System short codes can be dialed by all system users. However the system short code is ignored if the user dialing matches a user or user rights short code.

 **Warning:**

User dialing of emergency numbers must not be blocked. If short codes are edited, the users ability to dial emergency numbers must be tested and maintained.

These settings are mergeable. Changes to these settings do not require a reboot of the system.

Field	Description
<b>Code</b>	The dialing digits used to trigger the short code. Maximum length 31 characters.
<b>Feature</b>	Select the action to be performed by the short code.

*Table continues...*



Field	Description
<b>Telephone Number</b>	<p>The number dialed by the short code or parameters for the short code feature. This field can contain numbers and characters. For example, it can contain Voicemail Pro start point names, user names, hunt group names and telephone numbers (including those with special characters). Maximum length 31 characters.</p> <p>The majority of North-American telephony services use 'en-bloc' dialing, ie. they expect to receive all the routing digits for a call as a single simultaneous set of digits. Therefore the use of a ; is recommended at the end of all dialing short codes that use an <b>N</b>. This is also recommended for all dialing where secondary dial tone short codes are being used.</p>
<b>Line Group ID</b>	<p>Default = 0.</p> <p>For short codes that result in the dialing of a number, that is short codes with a <b>Dial</b> feature, this field is used to enter the initially routing destination of the call. The drop down can be used to select the following from the displayed list:</p> <ul style="list-style-type: none"> <li>• <b>Outgoing Group ID:</b> The Outgoing Group ID's current setup within the system configuration are listed. If an <b>Outgoing Group ID</b> is selected, the call will be routed to the first available line or channel within that group.</li> <li>• <b>ARS:</b> The ARS records currently configured in the system are listed. If an ARS record is selected, the call will be routed by the setting within that ARS record. Refer to ARS Overview.</li> </ul>
<b>Locale</b>	<p>Default = Blank.</p> <p>For short codes that route calls to voicemail, this field can be used to set the prompts locale that should be used if available on the voicemail server.</p>
<b>Force Account Code</b>	<p>Default = Off.</p> <p>For short codes that result in the dialing of a number, this field trigger the user being prompted to enter a valid account code before the call is allowed to continue.</p>
<b>Force Authorization Code</b>	<p>Default = Off.</p> <p>This option is only shown on systems where authorization codes have been enabled. If selected, then for short codes that result in the dialing of a number, the user is required to enter a valid authorization code in order to continue the call.</p>

### Related links

[Configuration Mode Field Descriptions](#) on page 197

---

## Service

### Normal, WAN, or Internet Services

Services are used to configure the settings required when a user or device on the LAN needs to connect to a off-switch data service such as the Internet or another network. Services can be used when making data connections via trunk or WAN interfaces.

Once a service is created, it can be used as the destination for an IP Route record. One service can also be set as the **Default Service**. That service will then be used for any data traffic received by the system for which no IP Route is specified.

The system supports the following types of service:

- **Normal Service** This type of service should be selected when for example, connecting to an ISP.
- **WAN Service** This type of service is used when creating a WAN link. A User and RAS Service will also be created with the same name. These three records are automatically linked and each open the same form. Note however, that this type of Service cannot be used if the Encrypted Password option is checked. In this case the RAS Service name must match the Account Name. Therefore either create each record manually or create an Intranet Service.
- **Intranet Service** This type of service can be selected to automatically create a User with the same name at the same time. These two records are linked and will each open the same form. The User's password is entered in the Incoming Password field at the bottom on the Service tab. An Intranet Services shares the same configuration tabs as those available to the WAN Service.

## SSL VPN Services

For full details on how to configure and administer SSL VPN services, refer to *Deploying Avaya IP Office™ Platform SSL VPN Services*.

### Related links

[Configuration Mode Field Descriptions](#) on page 197

[Service](#) on page 490

[Bandwidth](#) on page 491

[IP](#) on page 493

[Autoconnect](#) on page 495

[Quota](#) on page 495

[PPP](#) on page 496

[Fallback](#) on page 498

[Dial In](#) on page 499

[SSL VPN Service](#) on page 499

---

## Service

Navigation: [Service](#) | [Service](#)

### Additional configuration information

This type of configuration record can be saved as a template and new records created from a template. See [Working with Templates](#) on page 600.

### Configuration settings

These settings are mergeable. Changes to these settings do not require a reboot of the system.

Field	Description
<b>Service Name</b>	The name of the service. It is recommended that only alphanumeric characters be used.
<b>Account Name</b>	The user name that is used to authenticate the connection. This is provided by the ISP or remote system.
<b>Password</b>	Default = Blank Enter the password that is used to authenticate the connection. This is provided by the ISP or remote system.
<b>Telephone Number</b>	Default = Blank If the connection is to be made via ISDN enter the telephone number to be dialed. This is provided by the ISP or remote system.
<b>Firewall Profile</b>	Default = Internet01 if present, otherwise <None> From the list box select the Firewall Profile that is used to allow/disallow protocols through this Service.
<b>Encrypted Password</b>	Default = Off When enabled the password is authenticated via CHAP (this must also be supported at the remote end). If disabled, PAP is used as the authentication method.
<b>Default Route</b>	Default = Off When enabled this Service is the default route for data packets unless a blank IP Route has been defined in the system IP Routes. A green arrow appears to the left of the Service in the Configuration Tree. Only one Service can be the default route. If disabled, a route must be created under IP Route.
<b>Incoming Password</b>	Default = Blank Shown on WAN and Intranet services. Enter the password that will be used to authenticate the connection from the remote Control Unit. (If this field has appeared because you have created a Service and User of the same name, this is the password you entered in the User's Password field).

### Related links

[Service](#) on page 489

## Bandwidth

Navigation: **Service | Bandwidth**

These options give the ability to make ISDN calls between sites only when there is data to be sent or sufficient data to warrant an additional call. The calls are made automatically without the users being aware of when calls begin or end. Using ISDN it is possible to establish a data call and be passing data in less that a second.

### **Note:**

The system will check **Minimum Call Time** first, then **Idle Period**, then the **Active Idle Period**.

These settings are mergeable. Changes to these settings do not require a reboot of the system.

Field	Description
<b>Minimum No of Channels</b>	<p>Default = 1. Range = 1 to 30.</p> <p>Defines the number of channels used to connect for an outgoing connection. The initial channel must be established and stable, before further calls are made.</p>
<b>Maximum No of Channels</b>	<p>Default = 1. Range = 1 to 30.</p> <p>Defines the maximum number of channels to can be used. This field should contain a value equal to or greater than the Minimum Channels field.</p>
<b>Extra BW Threshold</b>	<p>Default = 50%. Range = 0 to 100%.</p> <p>Defines the utilization threshold at which extra channels are connected. The value entered is a %. The % utilization is calculated over the total number of channels in use at any time, which may be one, two etc.</p> <p>For example, if <b>Minimum Channels</b> set to 1, <b>Maximum Channels</b> set to 2 and <b>Extra Bandwidth</b> set to 50 - once 50% of first channel has been used the second channel is connected.</p>
<b>Reduce BW Threshold</b>	<p>Default = 10%. Range = 0 to 100%.</p> <p>Defines the utilization threshold at which additional channels are disconnected. The value entered is a %. Additional calls are only dropped when the % utilization, calculated over the total number of channels in use, falls below the % value set for a time period defined by the Service-Idle Time. The last call (calls - if Minimum Calls is greater than 1) to the Service is only dropped if the % utilization falls to 0, for a time period defined by the Service-Idle Time. Only used when 2 or more channels are set above.</p> <p>For example, if Minimum Channels set to 1, Maximum Channels set to 2 and Reduce Bandwidth is set to 10 - once the usage of the 2 channels drops to 10% the number of channels used is 1.</p>
<b>Callback Telephone Number</b>	<p>Default = Blank</p> <p>The number that is given to the remote service, via BAP, which the remote Control Unit then dials to allow the bandwidth to be increased. Incoming Call routing and RAS Services must be appropriately configured.</p>
<b>Idle Period (secs)</b>	<p>Default = 10 seconds. Range = 0 to 999999 seconds.</p> <p>The time period, in seconds, required to expire after the line has gone idle. At this point the call is considered inactive and is completely closed.</p> <p>For example, the 'Idle Period' is set to X seconds. X seconds before the 'Active Idle Period' timeouts the Control Unit checks the packets being transmitted/received, if there is nothing then at the end of the 'Active Idle Period' the session is closed &amp; the line is dropped. If there are some packets being transmitted or received then the line stays up. After the 'Active Idle Period' has timed out the system performs the same check every X seconds, until there are no packets being transferred and the session is closed and the line dropped.</p>

*Table continues...*

Field	Description
<b>Active Idle Period (secs):</b>	<p>Default = 180 seconds. Range = 0 to 999999 seconds.</p> <p>Sets the time period during which time the line has gone idle but there are still active sessions in progress (for example an FTP is in process, but not actually passing data at the moment). Only after this timeout will call be dropped.</p> <p>For example, you are downloading a file from your PC and for some reason the other end has stopped responding, (the remote site may have a problem etc.) the line is idle, not down, no data is being transmitted/ received but the file download session is still active. After the set time period of being in this state the line will drop and the sessions close. You may receive a remote server timeout error on your PC in the Browser/FTP client you were using.</p>
<b>Minimum Call Time (secs):</b>	<p>Default = 60 seconds. Range = 0 to 999999 seconds.</p> <p>Sets the minimum time that a call is held up after initial connection. This is useful if you pay a minimum call charge every time a call is made, no matter the actual length of the call. The minimum call time should be set to match that provided by the line provider.</p>
<b>Extra Bandwidth Mode</b>	<p>Default = Incoming Outgoing</p> <p>Defines the mode of operation used to increases bandwidth to the initial call to the remote Service. The options are:</p> <ul style="list-style-type: none"> <li>• <b>Outgoing Only</b> Bandwidth is added by making outgoing calls.</li> <li>• <b>Incoming Only</b> Bandwidth is added by the remote service calling back on the BACP number (assuming that BACP is successfully negotiated).</li> <li>• <b>Outgoing Incoming</b> Uses both methods but bandwidth is first added using outgoing calls.</li> <li>• <b>Incoming Outgoing</b> Uses both methods but bandwidth is first added using incoming BACP calls.</li> </ul>

### Related links

[Service](#) on page 489

---

## IP

Navigation: **Service | IP**

The fields in this tab are used to configure network addressing for the services you are running. Depending on how your network is configured, the use of Network Address Translation (NAT) may be required.

These settings are mergeable. Changes to these settings do not require a reboot of the system.

Field	Description
<b>IP Address</b>	<p>Default = 0.0.0.0 (address assigned by ISP)</p> <p>An address should only be entered here if a specific IP address and mask have been provided by the Service Provider. Note that if the address is in a different domain from the system then NAT is automatically enabled</p>
<b>IP Mask</b>	<p>Default = 0.0.0.0 (use NAT)</p> <p>Enter the IP Mask associated with the IP Address if an address is entered.</p>
<b>Primary Transfer IP Address</b>	<p>Default = 0.0.0.0 (No transfer)</p> <p>This address acts as a primary address for incoming IP traffic. All incoming IP packets without a session are translated to this address. This would normally be set to the local mail or web server address.</p> <p>For control units supporting a LAN1 and LAN2, the primary transfer address for each LAN can be set through the <b>System   LAN1</b> and <b>System   LAN2</b> tabs.</p>
<b>RIP Mode</b>	<p>Default = None</p> <p>Routing Information Protocol (RIP) is a method by which network routers can exchange information about device locations and routes. RIP can be used within small networks to allow dynamic route configuration as opposed to static configuration using. The options are:</p> <ul style="list-style-type: none"> <li>• <b>None</b> The LAN does not listen to or send RIP messages.</li> <li>• <b>Listen Only (Passive)</b> Listen to RIP-1 and RIP-2 messages in order to learn RIP routes on the network.</li> <li>• <b>RIP1</b> Listen to RIP-1 and RIP-2 messages and send RIP-1 responses as a sub-network broadcast.</li> <li>• <b>RIP2 Broadcast (RIP1 Compatibility)</b> Listen to RIP-1 and RIP-2 messages and send RIP-2 responses as a sub-network broadcast.</li> <li>• <b>RIP2 Multicast</b> Listen to RIP-1 and RIP-2 messages and send RIP-2 responses to the RIP-2 multicast address.</li> </ul>
<b>Request DNS</b>	<p>Default = Off.</p> <p>When selected, DNS information is obtained from the service provider. To use this, the DNS Server addresses set in the system configuration (System   DNS) should be blank. The PC making the DNS request should have the system set as its DNS Server. For DHCP clients the system will provide its own address as the DNS server.</p>
<b>Forward Multicast Messages</b>	<p>Default = On.</p> <p>By default this option is on. Multicasting allows WAN bandwidth to be maximized through the reduction of traffic that needs to be passed between sites.</p>

**Related links**

[Service](#) on page 489

---

## Autoconnect

Navigation: **Service | Autoconnect**

These settings enable you to set up automatic connections to the specified Service.

These settings are mergeable. Changes to these settings do not require a reboot of the system.

Field	Description
<b>Auto Connect Interval (mins):</b>	<p>Default = 0 (disabled). Range = 0 to 99999 minutes.</p> <p>This field defines how often this Service will automatically be called ("polled"). For example setting 60 means the system will call this Service every hour in the absence of any normally generated call (this timer is reset for every call; therefore if the service is already connected, then no additional calls are made). This is ideal for SMTP Mail polling from Internet Service Providers.</p>
<b>Auto Connect Time Profile</b>	<p>Default = &lt;None&gt;</p> <p>Allows the selection of any configured Time Profiles. The selected profile controls the time period during which automatic connections to the service are made. It does NOT mean that connection to that service is barred outside of these hours. For example, if a time profile called "Working Hours" is selected, where the profile is defined to be 9:00AM to 6:00PM Monday to Friday, then automatic connection to the service will not be made unless its within the defined profile. If there is an existing connection to the service at 9:00AM, then the connection will continue. If there is no connection, then an automatic connection will be made at 9:00AM.</p>

### Related links

[Service](#) on page 489



---

## Quota

Navigation: **Service | Quota**

Quotas are associated with outgoing calls, they place a time limit on calls to a particular IP Service. This avoids excessive call charges when perhaps something changes on your network and call frequency increases unintentionally.

These settings are mergeable. Changes to these settings do not require a reboot of the system.

Field	Description
<b>Quota Time (mins)</b>	<p>Default = 240 minutes. Range = 0 to 99999 minutes.</p> <p>Defines the number of minutes used in the quota. When the quota time is used up no further data can be passed to this service. This feature is useful to stop things like an internet game keeping a call to your ISP open for a long period.</p> <p> <b>Warning:</b></p> <p>Setting a value here without selecting a Quota period below will stop all further calls after the Quota Time has expired.</p>
<b>Quota:</b>	<p>Default = Daily. Range = None, Daily, Weekly or Monthly</p> <p>Sets the period during which the quota is applied. For example, if the <b>Quota Time</b> is 60 minutes and the <b>Quota</b> is set to <b>Daily</b>, then the maximum total connect time during any day is 60 minutes. Any time beyond this will cause the system to close the service and prevent any further calls to this service. To disable quotas select <b>None</b> and set a <b>Quota Time</b> of zero.</p> <p> <b>Note:</b></p> <p>The ClearQuota feature can be used to create short codes to refresh the quota time.</p>

**Related links**

[Service](#) on page 489

---

## PPP

Navigation: **Service | PPP**

These settings enable you to configure Point to Point Protocol (PPP) in relation to this particular service. PPP is a protocol for communication between two computers using a Serial interface.

These settings are mergeable. Changes to these settings do not require a reboot of the system.

Field	Description
<b>Chap Challenge Interval (secs)</b>	Default = 0 (disabled). Range = 0 to 99999 seconds. The period between CHAP challenges. Blank or 0 disables repeated challenges. Some software such as Windows 95 DUN does not support repeated CHAP challenges.
<b>Bi-Directional Chap</b>	Default =Off.
<b>Header Compression</b>	<p>Default = None selected</p> <p>Enables the negotiation and use of IP Header Compression. Supported modes are IPHC and VJ. IPHC should be used on WAN links.</p>

*Table continues...*



Field	Description
<b>PPP Compression Mode</b>	<p>Default = MPPC</p> <p>Enables the negotiate and use of compression. Do not use on VoIP WAN links. The options are:</p> <ul style="list-style-type: none"> <li>• <b>Disable</b> Do not use or attempt to use compression.</li> <li>• <b>StacLZS</b> Attempt to use STAC compression (Mode 3, sequence check mode).</li> <li>• <b>MPPC</b> Attempt to use MPPC compression. Useful for NT Servers.</li> </ul>
<b>PPP Callback Mode</b>	<p>Default = Disabled.</p> <p>The options are:</p> <ul style="list-style-type: none"> <li>• <b>Disable</b> Callback is not enabled</li> <li>• <b>LCP</b> (Link Control Protocol) After authentication the incoming call is dropped and an outgoing call to the number configured in the Service is made to re-establish the link.</li> <li>• <b>Callback CP</b> (Microsoft's Callback Control Protocol) After acceptance from both ends the incoming call is dropped and an outgoing call to the number configured in the Service is made to re-establish the link.</li> <li>• <b>Extended CBCP</b> (Extended Callback Control Protocol) Similar to Callback CP except the Microsoft application at the remote end prompts for a telephone number. An outgoing call is then made to that number to re-establish the link.</li> </ul>
<b>PPP Access Mode</b>	<p>Default = Digital64</p> <p>Sets the protocol, line speed and connection request type used when making outgoing calls. Incoming calls are automatically handled (see RAS services). The options are:</p> <ul style="list-style-type: none"> <li>• <b>Digital64</b> Protocol set to Sync PPP, rate 64000 bps, call presented to local exchange as a "Data Call".</li> <li>• <b>Digital56</b> As above but rate 56000 bps.</li> <li>• <b>Voice56</b> As above but call is presented to local exchange as a "Voice Call".</li> <li>• <b>V120</b> Protocol set to Async PPP, rate V.120, call presented to local exchange as a "Data Call". This mode runs at up to 64K per channel but has a higher Protocol overhead than pure 64K operation. Used for some bulletin board systems as it allows the destination end to run at a different asynchronous speed to the calling end.</li> <li>• <b>V110</b> Protocol is set to Async PPP, rate V.110. This runs at 9600 bps, call is presented to local exchange as a "Data Call". It is ideal for some bulletin boards.</li> <li>• <b>Modem</b> Allows Asynchronous PPP to run over an auto-adapting Modem to a service provider (requires a Modem2 card in the main unit)</li> </ul>
<b>Data Pkt. Size</b>	<p>Default = 0. Range = 0 to 2048.</p> <p>Sets the size limit for the Maximum Transmissible Unit.</p>
<b>BACP</b>	<p>Default = Off.</p> <p>Enables the negotiation and use of BACP/BCP protocols. These are used to control the addition of B channels to increase bandwidth.</p>

*Table continues...*

Field	Description
<b>Incoming traffic does not keep link up</b>	Default = On. When enabled, the link is not kept up for incoming traffic only.
<b>Multilink/QoS</b>	Default = Off. Enables the negotiation and use of Multilink protocol (MPPC) on links into this Service. Multilink must be enabled if there is more than one channel that is allowed to be Bundled/ Multilinked to this RAS Service.

**Related links**

[Service](#) on page 489

## Fallback

Navigation: **Service | Fallback**

These settings allow you to set up a fallback for the Service. For example, you may wish to connect to your ISP during working hours and at other times take advantage of varying call charges from an alternative carrier. You could therefore set up one Service to connect during peak times and another to act as fallback during the cheaper period.

You need to create an additional Service to be used during the cheaper period and select this service from the Fallback Service list box (open the Service form and select the Fallback tab).

If the original Service is to be used during specific hours and the Fallback Service to be used outside of these hours, a Time Profile can be created. Select this Time Profile from the Time Profile list box. At the set time the original Service goes into Fallback and the Fallback Service is used.

A Service can also be put into Fallback manually using short codes, for example:

**Put the service "Internet" into fallback:**

- **Short Code:** \*85
- **Telephone Number:** "Internet"
- **Line Group ID:** 0
- **Feature:** SetHuntGroupNightService

**Take the service "Internet" out of fallback:**

- **Short Code:** \*86
- **Telephone Number:** "Internet"
- **Line Group ID:** 0
- **Feature:** ClearHuntGroupNightService

These settings are mergeable. Changes to these settings do not require a reboot of the system.

Field	Description
<b>In Fallback</b>	Default = Off.  This option indicates whether the Service is in Fallback or not. A service can be set into fallback using this setting. Alternatively a service can be set into fallback using a time profile or short codes.
<b>Time profile</b>	Default = <None> (No automatic fallback)  Select the time profile you wish to use for the service. The time profile should be set up for the hours that you wish this service to be operational, out of these hours the Fallback Service is used.
<b>Fallback Service</b>	Default = <None>  Select the service that is used when this service is in fallback.

**Related links**

[Service](#) on page 489

---

**Dial In**

Navigation: **Service | Dial In**

Only available for WAN and Intranet Services. This tab is used to define a WAN connection.

To define a WAN connection, click Add and enter WAN if the service is being routed via a WAN port on a WAN3 expansion module.

These settings are mergeable. Changes to these settings do not require a reboot of the system.

**Related links**

[Service](#) on page 489

---

**SSL VPN Service**

The SSL VPN service provides secure tunneling between the Avaya IP Office hardware installed at a customer site and a remote Avaya VPN Gateway (AVG). This secure tunnel allows support personnel to offer remote management services to customers, such as fault management, monitoring, and administration.

For full details on how to configure and administer SSL VPN services, refer to *Deploying Avaya IP Office™ Platform SSL VPN Services*.

**Related links**

[Service](#) on page 489

[Service](#) on page 500

[Session](#) on page 500

[NAPT](#) on page 501

[Fallback](#) on page 502

## Service

Navigation: **SSL VPN Service | Service**

For Server Edition, this type of configuration record can be saved as a template and new records created from a template.

These settings are mergeable. Changes to these settings do not require a reboot of the system.

Field	Description
<b>Service Name</b>	Enter a name for the SSL VPN service.
<b>Account Name</b>	Enter the SSL VPN service account name. This account name is used for authenticating the SSL VPN service when connecting with the Avaya VPN Gateway (AVG).
<b>Account Password</b>	Enter the password for the SSL VPN service account.
<b>Confirm Password</b>	Confirm the password for the SSL VPN service account.
<b>Server Address</b>	Enter the address of the VPN gateway. The address can be a fully qualified domain name or an IPv4 address
<b>Server Type</b>	Default = AVG. This field is fixed to <b>AVG</b> (Avaya VPN Gateway).
<b>Server Port Number</b>	Default = 443. Select a port number.

### Related links

[SSL VPN Service](#) on page 499

## Session

Navigation: **SSL VPN Service | Session**

These settings are mergeable. Changes to these settings do not require a reboot of the system.

Field	Description
<b>Session Mode</b>	Default = Always On. This setting is greyed out and cannot be adjusted.
<b>Preferred Data Transport Protocol</b>	Default = UDP. This is the protocol used by the SSL VPN service for data transport. Only <b>TCP</b> is supported. If you select <b>UDP</b> as the protocol when you configure the connection, UDP displays in this field but the SSL VPN service falls back to TCP.
<b>Heartbeat Interval</b>	Default = 30 seconds. Range = 1 to 600 seconds. Enter the length of the interval between heartbeat messages, in seconds. The default value is 30 seconds.
<b>Heartbeat Retries</b>	Default = 4. Range = 1 to 10. Enter the number of unacknowledged heartbeat messages that IP Office sends to AVG before determining that AVG is not responsive. When this number of consecutive heartbeat messages is reached and AVG has not acknowledged them, IP Office ends the connection.

*Table continues...*

Field	Description
<b>Keepalive Interval</b>	Default = 10 seconds. Range = 0 (Disabled) to 600 seconds.  Not used for <b>TCP</b> connections. Keepalive messages are sent over the UDP data transport channel to prevent sessions in network routers from timing out.
<b>Reconnection Interval on Failure</b>	Default = 60 seconds. Range = 1 to 600 seconds.  The interval the system waits attempting to re-establish a connection with the AVG. The interval begins when the SSL VPN tunnel is in-service and makes an unsuccessful attempt to connect with the AVG, or when the connection with the AVG is lost. The default is 60 seconds.

### Related links

[SSL VPN Service](#) on page 499

## NAPT

Navigation: **SSL VPN Service | NAPT**

The Network Address Port Translation (NAPT) rules are part of SSL VPN configuration. NAPT rules allow a support service provider to remotely access LAN devices located on a private IP Office network. You can configure each SSL VPN service instance with a unique set of NAPT rules. You can configure up to 64 rules.

These settings are mergeable. Changes to these settings do not require a reboot of the system.

The SSL VPN restarts after a setting change.

Field	Description																								
<b>Application</b>	Default = Blank																								
	Defines the communication application used to connect to the LAN device through the SSL VPN tunnel. When you select an application, the <b>Protocol</b> and <b>Port Number</b> fields are filled with the default values. The drop-down <b>Application</b> selector options and the associated default values are:																								
	<table border="1"> <thead> <tr> <th>Application</th> <th>Protocol</th> <th>External and Internal Port Number</th> </tr> </thead> <tbody> <tr> <td>Custom</td> <td>TCP</td> <td>0</td> </tr> <tr> <td>VMPro</td> <td>TCP</td> <td>50791</td> </tr> <tr> <td>OneXPortal</td> <td>TCP</td> <td>8080</td> </tr> <tr> <td>SSH</td> <td>TCP</td> <td>22</td> </tr> <tr> <td>TELNET</td> <td>TCP</td> <td>23</td> </tr> <tr> <td>RDP</td> <td>TCP</td> <td>3389</td> </tr> <tr> <td>WebControl</td> <td>TCP</td> <td>7070</td> </tr> </tbody> </table>	Application	Protocol	External and Internal Port Number	Custom	TCP	0	VMPro	TCP	50791	OneXPortal	TCP	8080	SSH	TCP	22	TELNET	TCP	23	RDP	TCP	3389	WebControl	TCP	7070
	Application	Protocol	External and Internal Port Number																						
	Custom	TCP	0																						
	VMPro	TCP	50791																						
	OneXPortal	TCP	8080																						
	SSH	TCP	22																						
	TELNET	TCP	23																						
RDP	TCP	3389																							
WebControl	TCP	7070																							
<b>Protocol</b>	Default = TCP  The protocol used by the application. The options are <b>TCP</b> and <b>UDP</b> .																								

*Table continues...*

Field	Description
<b>External Port Number</b>	Default = the default port number for the application. Range = 0 to 65535 Defines the port number used by the application to connect from the external network to the LAN device in the customer private network.
<b>Internal IP address</b>	Default = Blank. The IP address of the LAN device in the customer network.
<b>Internal Port Number</b>	Default = the default port number for the application. Range = 0 to 65535 Defines the port number used by the application to connect to the LAN device in the customer private network.

**Related links**

[SSL VPN Service](#) on page 499

**Fallback**

Navigation: **SSL VPN Service | Fallback**

These settings are mergeable. Changes to these settings do not require a reboot of the system.

Field	Description
<b>In Fallback</b>	Default = Off.  This setting is used to indicate whether the SSL VPN service is in use or not. <ul style="list-style-type: none"> <li>• To configure the service without establishing an SSL VPN connection, or to disable an SSL VPN connection, select this option.</li> <li>• To enable the service and establish an SSL VPN connection, de-select this option.</li> <li>• The <b>Set Hunt Group Night Service</b> and <b>Clear Hunt Group Night Service</b> short code and button features can be used to switch an SSL VPN service off or on respectively. The service is indicated by setting the service name as the telephone number or action data. Do not use quotation marks.</li> </ul>

**Related links**

[SSL VPN Service](#) on page 499

**RAS**

Navigation: **RAS | RAS**

A Remote Access Server (RAS) is a piece of computer hardware which sits on a corporate LAN and into which employees dial on the public switched telephone network to get access to their email and to software and data on the corporate LAN.

This form is used to create a RAS service that the system offers Dial In users. A RAS service is needed when configuring modem dial in access, digital (ISDN) dial in access and a WAN link.

Some systems may only require one RAS service since the incoming call type can be automatically sensed.

These settings are mergeable. Changes to these settings do not require a reboot of the system.

Field	Description
<b>Name</b>	A textual name for this service. If <b>Encrypted Password</b> below is used, this name must match the <b>Account Name</b> entered in the Service form.
<b>Extension</b>	Enter an extension number if this service is to be accessed internally.
<b>COM Port</b>	For future use.
<b>TA Enable</b>	Default = Off  Select to enable or disable - if enabled RAS will pass the call onto a TA port for external handling.
<b>Encrypted Password</b>	Default = Off  This option is used to define whether Dial In users are asked to use PAP or CHAP during their initial log in to the RAS Service. If the Encrypted Password box is checked then Dial In users are sent a CHAP challenge, if the box is unchecked PAP is used as the Dial In Authorization method.

#### Related links

[Configuration Mode Field Descriptions](#) on page 197

[PPP](#) on page 503

## PPP

Navigation: **RAS | PPP**

PPP (Point-to-Point Protocol) is a Protocol for communication between two computers using a Serial interface, typically a personal computer connected by phone line to a server.

These settings are mergeable. Changes to these settings do not require a reboot of the system.

Field	Description
<b>CHAP Challenge Interval (secs)</b>	Default = 0 (disabled). Range = 0 to 99999 seconds.  The period between successive CHAP challenges. Blank or 0 disables repeated challenges. Some software, for example Windows 95 DUN, does not support repeated CHAP challenges.
<b>Header Compression</b>	Default = Off  Enables the negotiation and use of IP Header Compression as per RFC2507, RFC2508 and RFC2509.

*Table continues...*

Field	Description
<b>PPP Compression Mode</b>	<p>Default = MPPC This option is used to negotiate compression (or not) using CCP. If set to MPPC or StacLZS the system will try to negotiate this mode with the remote Control Unit. If set to Disable CCP is not negotiated. The options are:</p> <ul style="list-style-type: none"> <li>• <b>Disable</b> Do not use or attempt to use compression.</li> <li>• <b>StacLZS</b> Attempt to use and negotiate STAC compression (the standard, Mode 3)</li> <li>• <b>MPPC</b> Attempt to use and negotiate MPPC (Microsoft) compression. Useful for dialing into NT Servers.</li> </ul>
<b>PPP Callback Mode</b>	<p>Default = Disable</p> <p>The options are:</p> <ul style="list-style-type: none"> <li>• <b>Disable:</b> Callback is not enabled</li> <li>• <b>LCP:</b> (Link Control Protocol) After authentication the incoming call is dropped and an outgoing call to the number configured in the Service will be made to reestablish the link.</li> <li>• <b>Callback CP:</b> (Microsoft's Callback Control Protocol) After acceptance from both ends the incoming call is dropped and an outgoing call to the number configured in the Service is made to reestablish the link.</li> <li>• <b>Extended CBCP:</b> (Extended Callback Control Protocol) Similar to Callback CP however the Microsoft application at the remote end will prompt for a telephone number. An outgoing call will then be made to that number to reestablish the link.</li> </ul>
<b>Data Pkt. Size</b>	<p>Default = 0. Range = 0 to 2048.</p> <p>This is the number of data bytes contained in a Data Packet.</p>
<b>BACP</b>	<p>Default = Off</p> <p>Allows negotiation of the BACP/BCP protocols. These are used to control the addition of additional B channels to simultaneously improve data throughput.</p>
<b>Multilink</b>	<p>Default = Off</p> <p>When enabled the system attempts to negotiate the use of the Multilink protocol (MPPC) on the link(s) into this Service. Multilink must be enabled if the more than one channel is allowed to be Bundled/Multilinked to this RAS Service.</p>

**Related links**

[RAS](#) on page 502

## Incoming Call Route

Incoming call routes are used to determine the destination of voice and data calls received by the system. On systems where a large number incoming call routes need to be setup for DID numbers, the MSN/DID Configuration tool can be used.



Calls received on IP, S0 and QSIG trunks do not use incoming call routes. Routing for these is based on incoming number received as if dialed on-switch. Line short codes on those trunks can be used to modify the incoming digits.

For a Server Edition network, these settings can be configured at the network level and are then automatically replicated in the configuration of all systems in the network. They can only be seen and edited at the individual system configuration level if record consolidation is switched off.

Determining which incoming call route is used is based on the call matching a number of possible criteria. In order of highest priority first, the criteria, which if set must be matched by the call in order for the call to use that route are:

1. The **Bearer Capability** indicated, if any, with the call. For example whether the call is a voice, data or video call.
2. The **Incoming Group ID** of the trunk or trunk channel on which the call was received.
3. The **Incoming Number** received with the call.
4. The **Incoming Sub Address** received with the call.
5. The **Incoming CLI** of the caller.

### Multiple Matches

If there is a match between more than one incoming call route record, the one added to the configuration first is used.

### Incoming Call Route Destinations

Each incoming route can include a fallback destination for when the primary destination is busy. It can also include a time profile which control when the primary destination is used. Outside the time profile calls are redirected to a night service destination. Multiple time profiles can be associated with an incoming call route. Each time profile used has its own destination and fallback destination specified.

### Incoming Call Routing Examples

#### Example 1

For this example, the customer has subscribes to receive two 2-digit DID numbers. They want calls on one routed to a Sales hunt group and calls on the other to a Services hunt group. Other calls should use the normal default route to hunt group Main. The following incoming call routes were added to the configuration to achieve this:

Line Group	Incoming Number	Destination
0	77	Sales
0	88	Services
0	blank	Main

Note that the incoming numbers could have been entered as the full dialed number, for example 7325551177 and 7325551188 respectively. The result would still remain the same as incoming number matching is done from right-to-left.

Line Group	Incoming Number	Destination
------------	-----------------	-------------

*Table continues...*

0	7325551177	Sales
0	7325551188	Services
0	blank	Main

**Example 2**

In the example below the incoming number digits 77 are received. The incoming call route records 677 and 77 have the same number of matching digit place and no non-matching places so both a potential matches. In this scenario the system will use the incoming call route with the Incoming Number specified for matching.

Line Group	Incoming Number	Destination
0	677	Support
0	77	Sales
0	7	Services
0	blank	Main

**Example 3**

In the following example, the 677 record is used as the match for 77 as it has more matching digits than the 7 record and no non-matching digits.

Line Group	Incoming Number	Destination
0	677	Support
0	7	Services
0	blank	Main

**Example 4**

In this example the digits 777 are received. The 677 record had a non-matching digit, so it is not a match. The 7 record is used as it has one matching digit and no non-matching digits.

Line Group	Incoming Number	Destination
0	677	Support
0	7	Services
0	blank	Main

**Example 5**

In this example the digits 77 are received. Both the additional incoming call routes are potential matches. In this case the route with the shorter Incoming Number specified for matching is used and the call is routed to **Services**.

Line Group	Incoming Number	Destination
0	98XXX	Support
0	8XXX	Services
0	blank	Main

### Example 6

In this example two incoming call routes have been added, one for incoming number 6XXX and one for incoming number 8XXX. In this case, any three digit incoming numbers will potential match both routes. When this occurs, potential match that was added to the system configuration first is used. If 4 or more digits were received then an exact matching or non-matching would occur.

Line Group	Incoming Number	Destination
0	6XXX	Support
0	8XXX	Services
0	blank	Main

### Related links

[Configuration Mode Field Descriptions](#) on page 197

[Standard](#) on page 507

[Voice Recording](#) on page 511

[Destinations](#) on page 512

---

## Standard

Navigation: [Incoming Call Route | Standard](#)

### Additional configuration information

For additional information on the **Tag** setting, see [Call Tagging](#) on page 675.

Incoming call routes are used to match call received with destinations. Routes can be based on the incoming line group, the type of call, incoming digits or the caller's ICLID. If a range of MSN/DID numbers has been issued, this form can be populated using the MSN Configuration tool. In Manager, see **Tools > MSN Configuration**.

### Default Blank Call Routes

By default the configuration contains two incoming calls routes; one set for **Any Voice** calls (including analog modem) and one for **Any Data** calls. While the destination of these default routes can be changed, it is strongly recommended that the default routes are not deleted.

- Deleting the default call routes, may cause busy tone to be returned to any incoming external call that does not match any incoming call route.
- Setting any route to a blank destination field, may cause the incoming number to be checked against system short codes for a match. This may lead to the call being rerouted off-switch.

Calls received on IP, S0 and QSIG trunks do not use incoming call routes. Routing for these is based on incoming number received as if dialed on-switch. Line short codes on those trunks can be used to modify the incoming digits.

If there is no matching incoming call route for a call, matching is attempted against system short codes and finally against voicemail nodes before the call is dropped.

## SIP Calls

For SIP calls, the following fields are used for call matching:

- **Line Group ID** This field is matched against the **Incoming Group** settings of the SIP URI (Line | SIP URI). This must be an exact match.
- **Incoming Number** This field can be used to match the called details (TO) in the SIP header of incoming calls. It can contain a number, SIP URI or Tel URI. For SIP URI's the domain part of the URI is removed before matching by incoming call routing occurs. For example, for the SIP URI mysip@example.com , only the user part of the URI, ie. mysip, is used for matching.

The Call Routing Method setting of the SIP line can be used to select whether the value used for incoming number matching is taken from the **To Header** or the **Request URI** information provided with incoming calls on that line.

**Incoming CLI** This field can be used to match the calling details (FROM) in the SDP header of incoming SIP calls. It can contain a number, SIP URI, Tel URI or IP address received with SIP calls. For all types of incoming CLI except IP addresses a partial record can be used to achieve the match, records being read from left to right. For IP addresses only full record matching is supported.

## Configuration Settings

These settings are mergeable. Changes to these settings do not require a reboot of the system.

For a Server Edition network, these settings can be configured at the network level and are then automatically replicated in the configuration of all systems in the network. They can only be seen and edited at the individual system configuration level if record consolidation is switched off.

### Incoming Call Matching Fields:

The following fields are used to determine if the Incoming Call Route is a potential match for the incoming call. By default the fields are used for matching in the order shown starting with **Bearer Capability**.

Field	Description
<b>Line Group ID</b>	Default = 0. Range = 0 to 99999. Matches against the Incoming Line Group to which the trunk receiving the call belongs. For Server Edition systems, the default value <b>0</b> is not allowed. You must change the default value and enter the unique <b>Line Group ID</b> for the line.

*Table continues...*

Field	Description
<b>Incoming Number</b>	<p>Default = Blank (Match any unspecified)</p> <p>Matches to the digits presented by the line provider. A blank record matches all calls that do not match other records. By default this is a right-to-left matching. The options are:</p> <ul style="list-style-type: none"> <li>• <b>* = Incoming CLI Matching Takes Precedence</b></li> <li>• <b>- = Left-to-Right Exact Length Matching</b> Using a - in front of the number causes a left-to-right match. When left-to-right matching is used, the number match must be the same length. For example -96XXX will match a DID of 96000 but not 9600 or 960000.</li> <li>• <b>X = Single Digit Wildcard</b> Use X's to enter a single digit wild card character. For example <b>91XXXXXXXX</b> will only match DID numbers of at least 10 digits and starting with 91, <b>-91XXXXXXXX</b> would only match numbers of exactly 10 digits starting with 91. Other wildcard such as <b>N</b>, <b>n</b> and <b>?</b> cannot be used.</li> </ul> <p>Where the incoming number potentially matches two incoming call routes with X wildcards and the number of incoming number digits is shorter than the number of wildcards, the one with the shorter overall <b>Incoming Number</b> specified for matching is used.</p> <ul style="list-style-type: none"> <li>• <b>i = ISDN Calling Party Number 'National'</b> The <b>i</b> character does not affect the incoming number matching. It is used for Outgoing Caller ID Matching, see notes below.</li> </ul>
<b>Incoming CLI</b>	<p>Default = Blank (Match all) Enter a number to match the caller's ICLID provided with the call. This field is matched left-to-right. The number options are:</p> <ul style="list-style-type: none"> <li>• Full telephone number.</li> <li>• Partial telephone number, for example just the area code.</li> <li>• <b>!</b> : Matches calls where the ICLID was withheld.</li> <li>• <b>?</b> : for number unavailable.</li> <li>• Blank for all.</li> </ul>

### Call Setting Fields:

For calls routed using this Incoming Call Route, the settings of the following fields are applied to the call regardless of the destination.

Field	Description
<b>Locale</b>	<p>Default = Blank (Use system setting)</p> <p>This option specifies the language prompts, if available, that voicemail should use for the call if it is directed to voicemail.</p>

*Table continues...*

Field	Description
<b>Priority</b>	<p>Default = 1-Low. Range = 1-Low to 3-High.</p> <p>This setting allows incoming calls to be assigned a priority. Other calls such as internal calls are assigned priority <b>1-Low</b></p> <p>In situations where calls are queued, high priority calls are placed before calls of a lower priority. This has a number of effects:</p> <ul style="list-style-type: none"> <li>• Mixing calls of different priority is not recommended for destinations where Voicemail Pro is being used to provide queue ETA and queue position messages to callers since those values will no longer be accurate when a higher priority call is placed into the queue. Note also that Voicemail Pro will not allow a value already announced to an existing caller to increase.</li> <li>• If the addition of a higher priority call causes the queue length to exceed the hunt group's Queue Length Limit, the limit is temporarily raised by 1. This means that calls already queued are not rerouted by the addition of a higher priority call into the queue.</li> </ul> <p>A timer can be used to increase the priority of queued calls, see the setting <b>System   Telephony   Telephony   Call Priority Promotion Time</b>.</p> <p>The current priority of a call can be changed through the use of the <b>p</b> short code character in a short code used to transfer the call.</p>
<b>Tag</b>	<p>Default = Blank (No tag).</p> <p>Allows a text tag to be associated with calls routed by this incoming call route. This tag is displayed with the call within applications and on phone displays.</p>
<b>Hold Music Source</b>	<p>Default = System source.</p> <p>The system can support several music on hold sources. See <b>System   Telephony   Tones and Music</b>.</p> <p>If the system has several hold music sources available, this field allows selection of the source to associate with calls routed by this incoming call route. The new source selection will then apply even if the call is forwarded or transferred away from the Incoming Call Route destination. If the call is routed to another system in a multi-site network, the matching source on that system is used if available. The hold music source associated with a call can also be changed by a hunt group's Hold Music Source setting.</p>
<b>Ring Tone Override</b>	<p>Default = Blank</p> <p>If ring tones have been configured in <b>System   Telephony   Ring Tones</b>, they are available in this list. Setting a ring tone override applies a unique ring tone for the incoming call route. Ring tone override features are only supported on 1400 Series, 9500 Series and J100 Series (except J129) phones.</p>

### Outgoing Caller ID Matching

In cases where a particular Incoming Number is routed to a specific individual user, the system will attempt to use that Incoming Number as the user's caller ID when they make outgoing calls if no other number is specified. This requires that the Incoming Number is a full number suitable for user as outgoing caller ID and acceptable to the line provider.

When this is the case, the character **i** can also be added to the Incoming Number field. This character does not affect the incoming call routing. However when the same Incoming Number is

used for an outgoing caller ID, the calling party number plan is set to ISDN and the type is set to National. This option may be required by some network providers.

For internal calls being forwarded or twinned, if multiple incoming call route entries match the extension number used as caller ID, the first entry created is used. This entry should start with a “-” character (meaning fixed length) and provide the full national number. These entries do not support wildcards. If additional entries are required for incoming call routing, they should be created after the entry required for reverse lookup.

### Related links

[Incoming Call Route](#) on page 504

---

## Voice Recording

Navigation: [Incoming Call Route](#) | [Voice Recording](#)

These settings are used to activate the automatic recording of incoming calls that match the incoming call route.

Call recording requires Voicemail Pro to be installed and running. Call recording also requires available conference resources similar to a 3-way conference.

Note the following:

- Calls to and from IP devices, including those using Direct media, can be recorded.
- Calls parked or held pause recording until the unparked or taken off hold (does not apply to SIP terminals).
- Incoming call route voice recording continues for the duration of the call on the system or up to the maximum recording time configured on the voicemail server.
- Recording is stopped if:
  - User recording stops if the call is transferred to another user.
  - User account code recording stops if the call is transferred to another user.
  - Hunt group recording stops if the call is transferred to another user who is not a member of the hunt group.

These settings are mergeable. Changes to these settings do not require a reboot of the system.

Field	Description
<b>Record Inbound</b>	Default = None Select whether automatic recording of incoming calls is enabled. The options are: <ul style="list-style-type: none"> <li>• <b>None</b>: Do not automatically record calls.</li> <li>• <b>On</b>: Record the call if possible. If not possible to record, allow the call to continue.</li> <li>• <b>Mandatory</b>: Record the call if possible. If not possible to record, block the call and return busy tone.</li> <li>• <b>Percentages of calls</b>: Record a selected percentages of the calls.</li> </ul>

*Table continues...*

Field	Description
<b>Record Time Profile</b>	<p>Default = &lt;None&gt; (Any time)</p> <p>Used to select a time profile during which automatic call recording of incoming calls is applied. If no profile is selected, automatic recording of incoming calls is active at all times.</p>
<b>Recording (Auto)</b>	<p>Default = Mailbox</p> <p>Sets the destination for automatically triggered recordings. The options are:</p> <ul style="list-style-type: none"> <li>• <b>Mailbox</b> This option sets the destination for the recording to be a selected user or hunt group mailbox. The adjacent drop down list is used to select the mailbox.</li> <li>• <b>Voice Recording Library:</b> This options set the destination for the recording to be a VRL folder on the voicemail server. The ContactStore application polls that folder and collects waiting recordings which it then places in its own archive. Recording is still done by the Voicemail Pro.</li> <li>• <b>Voice Recording Library Authenticated:</b> This option is similar to Voice Recording Library above but instructs the voicemail server to create an authenticated recording. If the file contents are changed, the file is invalidated though it can still be played. This option is not currently supported with Linux based systems.</li> </ul>

**Related links**

[Incoming Call Route](#) on page 504

## Destinations

Navigation: [Incoming Call Route | Destinations](#)

The system allows multiple time profiles to be associated with an incoming call route. For each time profile, a separate Destination and Fallback Extension can be specified.

When multiple records are added, they are resolved from the bottom up. The record used will be the first one, working from the bottom of the list upwards, that is currently 'true', ie. the current day and time or date and time match those specified by the Time Profile. If no match occurs the Default Value options are used.

Once a match is found, the system does not use any other destination set even if the intended Destination and Fallback Extension destinations are busy or not available.

These settings are mergeable. Changes to these settings do not require a reboot of the system.

For a Server Edition network, these settings can be configured at the network level and are then automatically replicated in the configuration of all systems in the network. They can only be seen and edited at the individual system configuration level if record consolidation is switched off.



Field	Description
<b>Time Profile</b>	<p>This column is used to specify the time profiles used by the incoming call routes. It displays a drop-down list of existing time profiles from which a selection can be made. To remove an existing entry, select it by clicking on the button on the left of the row, then right-click on the row and select <b>Delete</b>.</p> <p>The <b>Default Value</b> entry is fixed and is used if no match to a time profile below occurs.</p>
<b>Destination</b>	<p>Default = Blank</p> <p>Either enter the destination manually or select the destination for the call from the drop-down list. The drop-down list contains all available extensions, users, groups, RAS services and voicemail. System short codes and dialing numbers can be entered manually. Once the incoming call is matched the call is passed to that destination.</p> <p>The following options appear in the drop-down list:</p> <ul style="list-style-type: none"> <li>• <b>Voicemail</b> allows remote mailbox access with voicemail. Callers are asked to enter the extension ID of the mailbox required and then the mailbox access code.</li> <li>• Local user names.</li> <li>• Local hunt groups names.</li> <li>• <b>AA: Name</b> directs calls to an Embedded Voicemail auto-attendant services.</li> </ul> <p>In addition to short codes, extension and external numbers, the following options can be also be entered manually:</p> <ul style="list-style-type: none"> <li>• <b>VM:Name</b> Directs calls to the matching start point in Voicemail Pro.</li> <li>• A . matches the Incoming Number field. This can be used even when X wildcards are being used in the Incoming Number field.</li> <li>• A # matches all X wildcards in the <b>Incoming Number</b> field. For example, if the Incoming Number was -91XXXXXXXXXXXX, the <b>Destination</b> of # would match XXXXXXXXXXXX.</li> <li>• Text and number strings entered here are passed through to system short codes, for example to direct calls into a conference. Note that not all short code features are supported.</li> <li>• If necessary, quote marks can be used to stop characters in the destination string being interpreted as special characters.</li> </ul>
<b>Fallback Extension</b>	<p>Default = Blank (No fallback)</p> <p>Defines an alternate destination which should be used when the current destination, set in the <b>Destination</b> field cannot be obtained. For example if the primary destination is a hunt group returning busy and without queuing or voicemail.</p>

### Related links

[Incoming Call Route](#) on page 504

## WAN Port

These settings are used to configure the operation of system WAN ports and services.

WAN services can be run over a T1 PRI trunk connection. This requires creation of a virtual WAN port. For full details refer to Using a Dedicated T1/PRI ISP Link.

### Related links

[Configuration Mode Field Descriptions](#) on page 197

[WAN Port](#) on page 514

[Frame Relay](#) on page 515

[DLCIs](#) on page 515

[Advanced](#) on page 517

## WAN Port

Navigation: **WAN Port** | **WAN Port**

Use these settings to configure a WAN port.

On IP500 V2 systems, these settings configure the leased line connected to the WAN port on the Control Unit. Normally this connection is automatically detected by the control unit. If a WAN Port is not displayed, connect the WAN cable, reboot the Control Unit and receive the configuration. The WAN Port configuration form is now be added.

These settings are not mergeable. Changes to these settings will require a reboot of the system.

Field	Description
<b>Name</b>	The physical ID of the Extension port,. This parameter is not configurable; it is allocated by the system.
<b>Speed</b>	The operational speed of this port. For example for a 128K connection, enter 128000. This should be set to the actual speed of the leased line as this value is used in the calculation of bandwidth utilization. If set incorrectly, additional calls may be made to increase Bandwidth erroneously.
<b>Mode</b>	Default = SyncPPP Select the protocol required. The options are: <ul style="list-style-type: none"> <li>• <b>SyncPPP</b> For a data link.</li> <li>• <b>SyncFrameRelay</b> For a link supporting Frame Relay.</li> </ul>
<b>RAS Name</b>	If the <b>Mode</b> is <b>SyncPPP</b> , selects the RAS service to associate with the port. If the <b>Mode</b> is <b>SyncFrameRelay</b> , the RAS Name is set through the DLCIs tab.

### Related links

[WAN Port](#) on page 514

---

## Frame Relay

Navigation: **WAN Port | Frame Relay**

These settings are for Frame Relay configuration.

These settings are not mergeable. Changes to these settings will require a reboot of the system.

Field	Description
<b>Frame Management Type</b>	<p>This must match the management type expected by the network provider. Selecting <b>AutoLearn</b> allows the system to automatically determine the management type based on the first few management frames received. If a fixed option is required the following options are supported:</p> <ul style="list-style-type: none"> <li>• <b>Q933 AnnexA 0393</b></li> <li>• <b>Ansi AnnexD</b></li> <li>• <b>FRFLMI</b></li> <li>• <b>None</b></li> </ul>
<b>Frame Learn Mode</b>	<p>This parameter allows the DLCIs that exist on the given WAN port to be provisioned in a number of different ways.</p> <ul style="list-style-type: none"> <li>• <b>None</b> No automatic learning of DLCIs. DLCIs must be entered and configured manually.</li> <li>• <b>Mgmt</b> Use LMI to learn what DLCIs are available on this WAN.</li> <li>• <b>Network</b> Listen for DLCIs arriving at the network. This presumes that a network provider will only send DLCIs that are configured for this particular WAN port.</li> <li>• <b>NetworkMgmt</b> Do both management and network listening to perform DLCI learning and creation.</li> </ul>
<b>Max Frame Length</b>	Maximum frame size that is allowed to traverse the frame relay network.
<b>Fragmentation Method</b>	<p>The options are:</p> <ul style="list-style-type: none"> <li>• <b>RFC1490</b></li> <li>• <b>RFC1490+FRF12</b></li> </ul>

### Related links

[WAN Port](#) on page 514

---

## DLCIs

Navigation: **WAN Port | DLCIs**

DLCIs are created for Frame Relay connections. These settings are not mergeable. Changes to these settings will require a reboot of the system.

Field	Description
<b>Frame Link Type</b>	<p>Default = PPP</p> <p>Data transfer encapsulation method. Set to the same value at both ends of the PVC (Permanent Virtual Channel). The options are:</p> <ul style="list-style-type: none"> <li>• <b>None</b></li> <li>• <b>PPP</b> Using PPP offers features such as out of sequence traffic reception, compression and link level connection management.</li> <li>• <b>RFC 1490</b> RFC 1490 encapsulation offers performance and ease of configuration and more inter-working with third party CPE.</li> <li>• <b>RFC1490 + FRF12</b> Alternate encapsulation to PPP for VoIP over Frame Relay. When selected all parameters on the Service   PPP tab being used are overridden.</li> </ul>
<b>DLCI</b>	<p>Default = 100 This is the Data Link Connection Identifier, a unique number assigned to a PVC end point that has local significance only. Identifies a particular PVC endpoint within a user's physical access channel in a frame relay.</p>
<b>RAS Name</b>	Select the RAS Service you wish to use.
<b>Tc</b>	<p>Default = 10</p> <p>This is the Time Constant in milliseconds. This is used for measurement of data traffic rates. The Tc used by the system can be shorter than that used by the network provider.</p>
<b>CIR</b>	<p>(Committed Information Rate) Default = 64000 bps This is the Committed Information Rate setting. It is the maximum data rate that the WAN network provider has agreed to transfer. The committed burst size (Bc) can be calculated from the set Tc and CIR as <math>Bc = CIR \times Tc</math>. For links carrying VoIP traffic, the Bc should be sufficient to carry a full VoIP packet including all its required headers. See the example below.</p>
<b>EIR</b>	<p>(Excess Information Rate) Default = 0 bps This is the maximum amount of data in excess of the CIR that a frame relay network may attempt to transfer during the given time interval. This traffic is normally marked as De (discard eligible). Delivery of De packets depends on the network provider and is not guaranteed and therefore they are not suitable for UDP and VoIP traffic. The excess burst size (Be) can be calculated as <math>Be = EIR \times Tc</math>.</p>

### Example: Adjusting the Tc Setting

G.729 VoIP creates a 20 byte packet every 20ms. Adding typical WAN PPP headers results in a 33 byte packet every 20ms.

For a Committed Information Rate (CIR) of 14Kbps, with the Time Constant (Tc) set to 10ms; we can calculate the Committed Burst size:

$$Bc = CIR \times Tc = 14,000 \times 0.01 = 140 \text{ bits} = 17.5 \text{ bytes.}$$

Using 10ms as the Tc, a full G.729 VoIP packet (33 bytes) cannot be sent without exceeding the Bc. The most likely result is lost packets and jitter.

If the Tc is increased to 20ms:

$$Bc = CIR \times Tc = 14,000 \times 0.02 = 280 \text{ bits} = 35 \text{ bytes.}$$

The Bc is now sufficient to carry a full G.729 VoIP packet.

**Notes:**

1. Backup over Frame Relay is not supported when the Frame Link Type is set to RFC1490.
2. When multiple DLCIs are configured, the WAN link LED is switched off if any of those DLCIs is made inactive, regardless of the state of the other DLCIs. Note also that the WAN link LED is switched on following a reboot even if one of the DLCIs is inactive. Therefore when multiple DLCIs are used, the WAN link LED cannot be used to determine the current state of all DLCIs.
3. When the Frame Link Type is set to RFC1490, the WAN link LED is switched on when the WAN cable is attached regardless other whether being connected to a frame relay network.

**Related links**

[WAN Port](#) on page 514

**Advanced**

Navigation: **WAN Port | Advanced**

These settings are used for Frame Relay connections.

These settings are not mergeable. Changes to these settings will require a reboot of the system.

Field	Description
<b>Address Length</b>	The address length used by the frame relay network. The network provider will indicate if lengths other than two bytes are to be used.
<b>N391</b>	Full Status Polling Counter Polling cycles count used by the CPE and the network provider equipment when bidirectional procedures are in operation. This is a count of the number of link integrity verification polls (T391) that are performed (that is Status Inquiry messages) prior to a Full Status Inquiry message being issued.
<b>N392</b>	Error Threshold Counter Error counter used by both the CPE and network provider equipment. This value is incremented for every LMI error that occurs on the given WAN interface. The DLCIs attached to the given WAN interface are disabled if the number of LMI errors exceeds this value when N393 events have occurred. If the given WAN interface is in an error condition then that error condition is cleared when N392 consecutive clear events occur.
<b>N393</b>	Monitored Events Counter Events counter measure used by both the CPE and network provider equipment. This counter is used to count the total number of management events that have occurred in order to measure error thresholds and clearing thresholds.
<b>T391</b>	Link Integrity Verification Polling Timer The link integrity verification polling timer normally applies to the user equipment and to the network equipment when bidirectional procedures are in operation. It is the time between transmissions of Status Inquiry messages.

*Table continues...*

Field	Description
T392	Polling Verification Timer The polling verification timer only applies to the user equipment when bidirectional procedures are in operation. It is the timeout value within which to receive a Status Inquiry message from the network in response to transmitting a Status message. If the timeout lapses an error is recorded (N392 incremented).

### Related links

[WAN Port](#) on page 514

---

## Directory Entry

Navigation: [Directory](#) | [Directory Entry](#)

### Additional configuration information

For additional configuration information, see [Centralized System Directory](#) on page 604.

### Configuration settings

Use these settings to create directory records that are stored in the system's configuration. Directory records can also be manually imported from a CSV file. The system can also use Directory Services to automatically import directory records from an LDAP server at regular intervals.

A system can also automatically import directory records from another system. Automatically imported records are used as part of the system directory but are not part of the editable configuration. Automatically imported records cannot override manually entered records.

For a Server Edition network, these settings can only be configured at the network level and they are stored in the configuration of the Primary Server. All other systems in the network are configured to share the directory settings of the Primary Server through their Manager settings at [System | Directory Services | HTTP](#).

### Directory Special Characters

The following characters are supported in directory records. They are supported in both system configuration records and in imported records.

- **? = Any Digit** Directory records containing a ? are only used for name matching against the dialed or received digits on outgoing or incoming calls. They are excluded from the dialable directory. In the following example, any calls where the dialed or received number that starts 9732555 will have the display name Holmdel associated with them.
  - **Name:** Holmdel
  - **Number:** 9732555?
- **( ) = Optional Digits** Brackets can be used to enclose an optional portion of a number, typically the area code. Only one pair of brackets are supported in a number. Records containing digits inside ( ) brackets are only used for user dialling. The full string is dialed with the ( ) brackets removed.

- **- Characters** Directory records can also contain - characters. Records containing - characters are only used for user dialing. The full string is dialed with the - character removed.

These settings are mergeable. Changes to these settings do not require a reboot of the system.

Field	Description
<b>Index</b>	Range = 000 to 999 or None.  This value is used with system speed dials dialed from M and T-Series phones. The value can be changed but each value can only be applied to one directory record at any time. Setting the value to <b>None</b> makes the speed dial inaccessible from M and T-Series phones, however it may still be accessible from the directory functions of other phone types and applications. The Speed Dial short code feature can be used to create short codes to dial the number stored with a specific index value.
<b>Name</b>	Enter the text, to be used to identify the number. Names should not begin with numbers.
<b>Number</b>	Enter the number to be matched with the above name. The number is processed against the applicable user and system short codes. Note that if the system has been configured to use an external dialing prefix, that prefix should be added to directory numbers.

#### Related links

[Configuration Mode Field Descriptions](#) on page 197

---

## Time Profile

Navigation: [Time Profile](#) | [Time Profile](#)

### Additional configuration information

This section provides the **Time Profiles** field descriptions.

For additional configuration information, see:

- [Configuring Time Profiles](#) on page 597
- The button action [Time Profile](#) on page 1063

### Configuration settings

For a time profile with multiple records, for example a week pattern and some calendar records, the profile is valid when any entry is valid. For Server Edition, this type of configuration record can be saved as a template and new records created from a template.

These settings are mergeable. Changes to these settings do not require a reboot of the system.

For a Server Edition network, these settings can be configured at the network level and are then automatically replicated in the configuration of all systems in the network. They can only be seen and edited at the individual system configuration level if record consolidation is switched off.

Field	Description
<b>Name</b>	<p>Range = Up to 15 characters</p> <p>This name is used to select the time profile from within other tabs.</p>
<b>Manual Override</b>	<p>Default = Off.</p> <p>You can manually override a time profile. The override settings allow you to mix timed and manual settings. The options are:</p> <ul style="list-style-type: none"> <li>• <b>Active Until Next Timed Inactive:</b> Use for time profiles with multiple intervals. Select to make the current timed interval active until the next inactive interval.</li> <li>• <b>Inactive Until Next Timed Active:</b> Use for time profiles with multiple intervals. Select to make the current active timed interval inactive until the next active interval.</li> <li>• <b>Latch Active:</b> Set the time profile to active. Timed inactive periods are overridden and remain active. The setting is retained over a reboot.</li> <li>• <b>Latch Inactive:</b> Set the time profile to inactive. Timed active periods are overridden and remain active. The setting is retained over a reboot.</li> </ul>
<b>Time Entry List</b>	
<p>This list shows the current periods during which the time profile is active. Clicking on an existing entry will display the existing settings and allows them to be edited if required. To remove an entry, selecting it and then click on <b>Remove</b> or right-click and select <b>Delete</b>.</p>	
<b>Recurrence Pattern (Weekly Time Pattern)</b>	<p>When a new time entry is required, click <b>Add Recurring</b> and then enter the settings for the entry using the fields displayed. Alternately right-click and select <b>Add Recurring Time Entry</b>. This type of entry specific a time period and the days on which it occurs, for example 9:00 - 12:00, Monday to Friday. A time entry cannot span over two days. For example you cannot have a time profile starting at 18:00 and ending 8:00. If this time period is required two Time Entries should be created - one starting at 18:00 and ending 11:59, the other starting at 00:00 and ending 8:00.</p> <ul style="list-style-type: none"> <li>• <b>Start Time</b> The time at which the time period starts.</li> <li>• <b>End Time</b> The time at which the time period ends. Note that the endtime is at the end of the minute, for example 11:00 is interpreted as 11:00:59, not 11:00:00.</li> <li>• <b>Days of Week</b> The days of the week to which the time period applies.</li> </ul>
<b>Recurrence Pattern (Calendar Date)</b>	<p>When a new calendar date entry is required, click <b>Add Date</b> and then enter the settings required. Alternately right-click and select <b>Add Calendar Time Entry</b>. Calendar records can be set for up to the end of the next calendar year.</p> <ul style="list-style-type: none"> <li>• <b>Start Time</b> The time at which the time period starts.</li> <li>• <b>End Time</b> The time at which the time period ends.</li> <li>• <b>Year</b> Select either the current year or the next calendar year.</li> <li>• <b>Date</b> To select or de-select a particular day, double-click on the date. Selected days are shown with a dark gray background. Click and drag the cursor to select or de-select a range of days.</li> </ul>

**Related links**

[Configuration Mode Field Descriptions](#) on page 197



---

## Firewall Profile

The system can act as a firewall, allowing only specific types of data traffic to start a session across the firewall and controlling in which direction such sessions can be started.

The system supports Static NAT address translation by a firewall profiles. If the Firewall Profile contains any Static NAT records, all packets received by the firewall must match one of those static NAT records to not be blocked.

If Network Address Translation (NAT) is used with the firewall (which it typically is), then you must also configure the setting **Service | IP | Primary Trans. IP Address** if you wish sessions to be started into your site (typically for SMTP) from the Internet.

On Server Edition Linux systems, to ensure that the firewall starts after a reboot, you must enable the **Activate** setting in the Web Control menus. See *Using the Server Edition Web Control Menus*.

System firewall profiles can be applied in the following areas of operation.

### System:

A firewall profile can be selected to be applied to traffic between LAN1 and LAN2.

### User:

Users can be used as the destination of incoming RAS calls. For those users a firewall profile can be selected on the user's Dial In tab.

### Service:

Services are used as the destination for IP routes connection to off-switch data services such as the internet. A Firewall Profile can be selected for use with a service.

### Related links

[Configuration Mode Field Descriptions](#) on page 197

[Firewall | Standard](#) on page 521

[Firewall | Custom](#) on page 523

[Static NAT](#) on page 525

---

## Firewall | Standard

Navigation: **Firewall Profile | Standard**

### Additional configuration information

This type of configuration record can be saved as a template and new records created from a template. See [Working with Templates](#) on page 600.

### Configuration settings

By default, any protocol not listed in the standard firewall list is dropped unless a custom firewall entry is configured for that protocol.

These settings are mergeable. Changes to these settings do not require a reboot of the system.

Field	Description		
<b>Name</b>	Range = Up to 15 characters. Enter the name to identify this profile.		
<b>Protocol Control</b>	For each of the listed protocols, the options <b>Drop</b> , <b>In</b> (Incoming traffic can start a session), <b>Out</b> (Outgoing traffic can start a session) and <b>Both Directions</b> can be selected. Once a session is started, return traffic for that session is also able to cross the firewall.		
	<b>Protocol</b>	<b>Default</b>	<b>Description</b>
	<b>TELNET</b>	Out	Remote terminal log in.
	<b>FTP</b>	Out	File Transfer Protocol.
	<b>SMTP</b>	Out	Simple Mail Transfer Protocol.
	<b>TIME</b>	Out	Time update protocol.
	<b>DNS</b>	Out	Domain Name System.
	<b>GOPHER</b>	Drop	Internet menu system.
	<b>FINGER</b>	Drop	Remote user information protocol.
	<b>RSVP</b>	Drop	Resource Reservation Protocol.
	<b>HTTP/S</b>	Bothway	Hypertext Transfer Protocol.
	<b>POP3</b>	Out	Post Office Protocol.
	<b>NNTP</b>	Out	Network News Transfer Protocol.
	<b>SNMP</b>	Drop	Simple Network Management Protocol.
	<b>IRC</b>	Out	Internet Relay Chat.
<b>PPTP</b>	Drop	Point to Point Tunneling Protocol.	
<b>IGMP</b>	Drop	Internet Group Membership Protocol.	
<b>Service Control</b>	For each of the listed services, the options <b>Drop</b> , <b>In</b> , <b>Out</b> and <b>Both Directions</b> can be selected. Once a session is started, return traffic for that session is also able to cross the firewall.		
	<b>Protocol</b>	<b>Default</b>	<b>Description</b>
	<b>SSI</b>	In	System Status Application access.
	<b>SEC</b>	Drop	TCP security settings access.
	<b>CFG</b>	Drop	TCP configuration settings access.
	<b>TSPI</b>	In	TSPI service access.
	<b>WS</b>	Drop	IP Office web management services.

**Related links**

[Firewall Profile](#) on page 521

---

## Firewall | Custom

Navigation: **Firewall Profile | Custom**

The tab lists custom firewall settings added to the firewall profile. The Add, Edit and Remove controls can be used to amend the settings in the list.

### Example Custom Firewall Records

#### Dropping NetBIOS searches on an ISPs DNS:

We suggest that the following filter is always added to the firewall facing the Internet to avoid costly but otherwise typically pointless requests from Windows machines making DNS searches on the DNS server at your ISP.

**Direction:** Drop

**IP Protocol:** 6 (TCP)

**Match Offset:** 20

**Match Length:** 4

**Match Data:** 00890035

**Match Mask:** FFFFFFFF

#### Browsing Non-Standard Port Numbers:

The radio button for HTTP permits ports 80 and 443 through the firewall. Some hosts use non-standard ports for HTTP traffic, for example 8080, 8000, 8001, 8002, etc. You can add individual filters for these ports as you find them.

You wish to access a web page but you cannot because it uses TCP port 8000 instead of the more usual port 80, use the entry below.

**Direction:** Out

**IP Protocol:** 6 (TCP)

**Match Offset:** 22

**Match Length:** 2

**Match Data:** 1F40

**Match Mask:** FFFF

A more general additional entry given below allows all TCP ports out.

**Direction:** Out

**IP Protocol:** 6 (TCP)

**Match Offset:** 0

**Match Length:** 0

**Match Data:** 00000000000000000000000000000000

**Match Mask:** 00000000000000000000000000000000

**Routing All Internet Traffic through a WinProxy:**

If you wish to put WinProxy in front of all Internet traffic via the Control Unit. The following firewall allows only the WinProxy server to contact the Internet : -

1. Create a new Firewall profile and select **Drop** for all protocols
2. Under Custom create a new Firewall Entry
3. In Notes enter the name of the server allowed. Then use the default settings except in Local IP Address enter the IP address of the WinProxy Server, in Local IP Mask enter 255.255.255.255 and in Direction select Both Directions.

**Stopping PINGs:**

You wish to stop pings - this is ICMP Filtering. Using the data below can create a firewall filter that performs the following; Trap Pings; Trap Ping Replies; Trap Both.

**Trap Pings:** Protocol = 1, offset = 20, data = 08, mask = FF

**Trap Ping Replies:** Protocol = 1, offset = 20, data = 00, mask = FF

**Trap Both:** Protocol = 1, offset = 20, data = 00, mask = F7, Traps Both.

These settings are mergeable. Changes to these settings do not require a reboot of the system.

Field	Description
<b>Notes</b>	For information only. Enter text to remind you of the purpose of the custom firewall record.
<b>Remote IP Address</b>	The IP address of the system at the far end of the link. Blank allows all IP addresses.
<b>Remote IP Mask</b>	The mask to use when checking the Remote IP Address. When left blank no mask is set, equivalent to 255.255.255.255 - allow all.
<b>Local IP Address</b>	The address of devices local to this network (pre-translated). Blank allows all IP addresses.
<b>Local IP Mask</b>	The mask to use when checking the Local IP Address. When left blank no mask is set, equivalent to 255.255.255.255 - allow all.
<b>IP Protocol</b>	The value entered here corresponds to the IP Protocol which is to be processed by this Firewall profile: 1 for ICMP, 6 for TCP, 17 for UDP or 47 for GRE. This information can be obtained from the "pcol" parameter in a Monitor trace.
<b>Match Offset</b>	The offset into the packet (0 = first byte of IP packet) where checking commences for either a specific port number, a range of port numbers, or data.
<b>Match Length</b>	The number of bytes to check in the packet, from the Match Offset point, that are checked against the Match Data and Match Mask settings.
<b>Match Data</b>	The values the data must equal once masked with the Match Mask. This information can be obtained from "TCP Dst" parameter in a Monitor trace (the firewall uses hex so a port number of 80 is 50 in hex)
<b>Match Mask</b>	This is the byte pattern, which is logically ANDed with the data in the packet from the offset point. The result of this process is then compared against the contents of the "Match Data" field.

*Table continues...*

Field	Description	
Direction	The direction that data may take if matching this filter.	
	Drop	All matching traffic is dropped.
	In	Incoming traffic can start a session.
	Out	Outgoing traffic can start a session.
	Both Directions	Both incoming and outgoing traffic can start sessions.

#### Related links

[Firewall Profile](#) on page 521

---

## Static NAT

Navigation: [Firewall Profile](#) | [Static NAT](#)

The **Static NAT** table allows the firewall to perform address translation between selected internal and external IP addresses. Up to 64 internal and external IP address pairs can be added to the Static NAT section of a Firewall Profile.

This feature is intended for incoming maintenance access using applications such as PC-Anywhere, Manager and the Voicemail Pro Client. The address translation is used for destinations such a Voicemail Pro server or the system's own LAN1 address.

- If there are any records in the **Static NAT** settings of a Firewall Profile, each packet attempting to pass through the firewall must match one of the static NAT pairs or else the packet will be dropped.
- The destination address of incoming packets is checked for a matching **External IP Address**. If a match is found, the target destination address is changed to the corresponding **Internal IP Address**.
- The source address of outgoing packets is checked for a matching **Internal IP Address**. If a match is found, the source address is changed to the corresponding **External IP Address**.
- Even when a static NAT address match occurs, the other settings on the Firewall Profile Standard and Custom tabs are still applied and may block the packet.

#### Related links

[Firewall Profile](#) on page 521

---

## IP Route

### Additional configuration information

This section provides the IP Route field descriptions. For additional configuration information, see [Configuring IP Routes](#) on page 653.

**Related links**

- [Configuration Mode Field Descriptions](#) on page 197
- [IP Route | IP Route](#) on page 526
- [RIP Dynamic Routing](#) on page 527

## IP Route | IP Route

Navigation: [IP Route | IP Route](#)

**Additional configuration information**

For additional configuration information, see [Configuring IP Routes](#) on page 653.

**Configuration settings**

These settings are used to setup static IP routes from the system. These are in addition to RIP if RIP is enabled on LAN1 and or LAN2. Up to 100 routes are supported.

For Server Edition, this type of configuration record can be saved as a template and new records created from a template.

 **Warning:**

The process of 'on-boarding' (refer to the IP Office SSL VPN Solutions Guide) may automatically add a static route to an SSL VPN service in the system configuration when the on-boarding file is uploaded to the system. Care should be taken not to delete or amend such a route except when advised to by Avaya.

These settings are mergeable. Changes to these settings do not require a reboot of the system.

Field	Description
<b>IP Address</b>	The IP address to match for ongoing routing. Any packets meeting the IP Address and IP Mask settings are routed to the entry configured in the <b>Destination</b> field. When left blank then an IP Address of 255.255.255.255 (all) is used.
<b>IP Mask</b>	The subnet mask used to mask the IP Address for ongoing route matching. If blank, the mask used is 255.255.255.255 (all).  A <b>0.0.0.0</b> entry in the IP Address and IP Mask fields routes all packets for which there is no other specific IP Route available. The Default Route option with Services can be used to do this if a blank IP route is not added.
<b>Gateway IP Address</b>	Default = Blank The address of the gateway where packets for the above address are to be sent. If this field is set to <b>0.0.0.0</b> or is left blank then all packets are just sent down to the <b>Destination</b> specified, not to a specific IP Address. This is normally only used to forward packets to another Router on the local LAN.
<b>Destination</b>	Allows selection of LAN1, LAN2 and any configured Service, Logical LAN or Tunnel (L2TP only).
<b>Metric:</b>	Default = 0  The number of "hops" this route counts as.

*Table continues...*

Field	Description
Proxy ARP	Default = Off This allows the system to respond on behalf of this IP address when receiving an ARP request.

### Related links

[IP Route](#) on page 525

## RIP Dynamic Routing

Navigation: [IP Route](#) | [RIP Dynamic Routing](#)

Routing Information Protocol (RIP) is a protocol which allows routers within a network to exchange routes of which they are aware approximately every 30 seconds. Through this process, each router adds devices and routes in the network to its routing table.

Each router to router link is called a 'hop' and routes of up to 15 hops are created in the routing tables. When more than one route to a destination exists, the route with the lowest metric (number of hops) is added to the routing table.

When an existing route becomes unavailable, after 5 minutes it is marked as requiring 'infinite' (16 hops). It is then advertised as such to other routers for the next few updates before being removed from the routing table. The system also uses 'split horizon' and 'poison reverse'.

RIP is a simple method for automatic route sharing and updating within small homogeneous networks. It allows alternate routes to be advertised when an existing route fails. Within a large network the exchange of routing information every 30 seconds can create excessive traffic. In addition the routing table held by each system is limited to 100 routes (including static and internal routes).

It can be enabled on LAN1, LAN2 and individual services. The normal default is for RIP to be disabled.

- **Listen Only (Passive):** The system listens to RIP1 and RIP2 messages and uses these to update its routing table. However the system does not respond.
- **RIP1:** The system listens to RIP1 and RIP2 messages. It advertises its own routes in a RIP1 sub-network broadcast.
- **RIP2 Broadcast (RIP1 Compatibility):** The system listens to RIP1 and RIP2 messages. It advertises its own routes in a RIP2 sub-network broadcast. This method is compatible with RIP1 routers.
- **RIP2 Multicast:** The system listens to RIP1 and RIP2 messages. It advertises its own routes to the RIP2 multicast address (249.0.0.0). This method is not compatible with RIP1 routers.

Broadcast and multicast routes (those with addresses such as 255.255.255.255 and 224.0.0.0) are not included in RIP broadcasts. Static routes (those in the IP Route table) take precedence over a RIP route when the two routes have the same metric.

### Related links

[IP Route](#) on page 525

---

## Account Code

### Additional configuration information

This section provides the **Account Code** field descriptions. For additional configuration information, see [Configuring Account Codes](#) on page 683.

Account codes are commonly used to control cost allocation and out-going call restriction. The account code used on a call is included in the call information output by the system's call log. Incoming calls can also trigger account codes automatically by matching the Caller ID stored with the account code.

For a Server Edition network, these settings can be configured at the network level and are then automatically replicated in the configuration of all systems in the network. They can only be seen and edited at the individual system configuration level if record consolidation is switched off.

Once a call has been completed using an account code, the account code information is removed from the user's call information. This means that re-dial functions will not re-enter the account code. The maximum recommended number of accounts codes is 1000.

### Related links

[Configuration Mode Field Descriptions](#) on page 197

---

## Account Code

Navigation: **Account Code** | **Account Code**

These settings are mergeable. Changes to these settings do not require a reboot of the system.

For a Server Edition network, these settings can be configured at the network level and are then automatically replicated in the configuration of all systems in the network. They can only be seen and edited at the individual system configuration level if record consolidation is switched off.

Field	Descriptions
<b>Account Code</b>	Enter the account code required. It can also include wildcards; ? matches a single digit and * matches any digits.
<b>Caller ID</b>	A caller ID can be entered and used to automatically assign an account code to calls made to or received from caller ID.

---

## Voice Recording

Navigation: **Account Code** | **Voice Recording**

These settings are used to activate the automatic recording of external calls when the account code is entered at the start of the call.

Call recording requires Voicemail Pro to be installed and running. Call recording also requires available conference resources similar to a 3-way conference.



Note the following:

- Calls to and from IP devices, including those using Direct media, can be recorded.
- Calls parked or held pause recording until the unparked or taken off hold (does not apply to SIP terminals).
- Account code voice recording continues for the duration of the call on the system or up to the maximum recording time configured on the voicemail server.
- Recording is stopped if:
  - User recording stops if the call is transferred to another user.
  - User account code recording stops if the call is transferred to another user.
  - Hunt group recording stops if the call is transferred to another user who is not a member of the hunt group.

The destination mailbox for the recording can be specified.

These settings are mergeable. Changes to these settings do not require a reboot of the system.

For a Server Edition network, these settings can be configured at the network level and are then automatically replicated in the configuration of all systems in the network. They can only be seen and edited at the individual system configuration level if record consolidation is switched off.

Field	Description
<b>Record Outbound</b>	Default = None Select whether automatic recording of outgoing calls is enabled. The Auto Record Calls option sets whether just external calls or external and internal calls are included. The options are: <ul style="list-style-type: none"> <li>• <b>None:</b> Do not automatically record calls.</li> <li>• <b>On:</b> Record the call if possible. If not possible to record, allow the call to continue.</li> <li>• <b>Mandatory:</b> Record the call if possible. If not possible to record, block the call and return busy tone.</li> <li>• <b>Percentages of calls:</b> Record a selected percentages of the calls.</li> </ul>
<b>Record Time Profile</b>	Default = <None> (Any time) Used to select a time profile during which automatic call recording of outgoing calls is applied. If no profile is selected, automatic recording of outgoing calls is active at all times.

*Table continues...*

Field	Description
<b>Recording (Auto)</b>	<p>Default = Mailbox</p> <p>Sets the destination for automatically triggered recordings. The options are:</p> <ul style="list-style-type: none"> <li>• <b>Mailbox</b> This option sets the destination for the recording to be a selected user or hunt group mailbox. The adjacent drop down list is used to select the mailbox.</li> <li>• <b>Voice Recording Library:</b> This options set the destination for the recording to be a VRL folder on the voicemail server. The ContactStore application polls that folder and collects waiting recordings which it then places in its own archive. Recording is still done by the Voicemail Pro.</li> <li>• <b>Voice Recording Library Authenticated:</b> This option is similar to Voice Recording Library above but instructs the voicemail server to create an authenticated recording. If the file contents are changed, the file is invalidated though it can still be played. This option is not currently supported with Linux based systems.</li> </ul>

## Subscription

Navigation: **Subscription| Subscription**

Subscriptions are monthly paid entitlements used by IP Office Subscription mode systems. They can be divided into two main groups; per-user per-month user subscriptions and per-month application subscriptions.

Subscription are ordered from the Avaya Channel Marketplace, using the unique ID number of the system. Once ordered, details of the customer number and address of the subscription server are supplied in an email. Those details are then used during the initial system configuration.

Field	Descriptions
<b>System ID</b>	<p>The unique number used for validation of subscriptions.</p> <ul style="list-style-type: none"> <li>• For IP500 V2 systems, this is the System SD card's PLDS ID as printed on the card. For older cards with 10-digits ID, the number is prefixed with 11.</li> <li>• For other systems, the ID is a unique value based on elements of the system hardware at the time of system installation.</li> </ul>
<b>Customer ID</b>	This number is supplied in the email provided when the <b>System ID</b> is subscribed with Avaya.
<b>Customer Name</b>	The customer name used when the <b>System ID</b> was subscribed.
<b>License Server</b>	This address is supplied in the email provided when the <b>System ID</b> is subscribed with Avaya.

*Table continues...*

Field	Descriptions
<b>Application Subscriptions</b>	<p>The following application subscriptions can be ordered for a IP Office Subscription system:</p> <ul style="list-style-type: none"> <li>• <b>User Subscriptions</b> <ul style="list-style-type: none"> <li>- <b>Telephony User</b> – Enables a user with telephony functions using a deskphone.</li> <li>- <b>Telephony Plus User</b> – Enable a user with telephony functions using an deskphone and or a softphone client on a PC.</li> <li>- <b>UC User</b> – Enable a user with the full range of telephony functions.</li> </ul> </li> <li>• <b>Application Subscriptions</b> <ul style="list-style-type: none"> <li>- <b>Receptionist Console</b> – This subscription is used to enable the IP Office SoftConsole application to answer and redirect calls. The number of subscriptions allows the matching number of users to be configured as <b>Receptionist</b> users. Those users still require a user subscriptions for their telephone connection (IP Office SoftConsole is not a softphone).</li> <li>- <b>Media Manager</b> – This subscription enables support for the Media Manager service. This uses the Voicemail Pro service, running on the same server, to archive call recordings. This option is not supported if using a Unified Communications Module.</li> <li>- <b>Third-Party CTI</b> – This subscription enables support for CTI connections by third-party applications. This includes DevLink, DevLink3, 3rd-party TAPI and TAPI WAV.</li> <li>- <b>Avaya Contact Center Select</b> – This subscription enables support the Avaya Contact Center Select (ACCS) service hosted on a separate server.</li> <li>- <b>Avaya Call Reporter</b> – This subscription enables support for the Avaya Call Reporter application, hosted on a separate server.</li> </ul> </li> </ul>

**Related links**

[Configuration Mode Field Descriptions](#) on page 197

---

## License

**Additional configuration information**

This section provides the Licenses field descriptions.

 **Note:**

This section is not applicable to systems running in subscription mode.

For additional configuration information on licensing, see the following.

- [Applying Licenses](#) on page 567.
- [Converting from Nodal Licensing to Centralized Licensing](#) on page 579

- [Migrating ADI Licenses to PLDS](#) on page 580
- “Licenses” in *Avaya IP Office™ Platform Solution Description*.

**Related links**

[Configuration Mode Field Descriptions](#) on page 197

[License](#) on page 532

[Remote Server](#) on page 534

## License

Navigation: **License | License**

These settings are mergeable. Changes to these settings do not require a reboot of the system.

Name	Description			
<b>License Mode</b>	<p>Identifies the status of the system licenses. The two license configuration types are nodal and WebLM. Nodal licenses are licenses that are present on the system. WebLM licenses means licenses obtained from the WebLM server.</p> <p>The possible states are:</p> <ul style="list-style-type: none"> <li>• <b>Normal Mode</b> Normal nodal licensing mode. In this mode, WebLM is not configured and only nodal licensing is allowed.</li> <li>• <b>Server Error</b> This mode occurs when transitioning to WebLM licensing. WebLM has been configured but the server is not available.</li> <li>• <b>Configuration Error</b> This mode occurs when transitioning to WebLM licensing. WebLM has been configured and the server is available, but there are not enough licenses available to license all of the configured features. Only nodal licenses are valid on Standard mode IP500 V2 systems.</li> <li>• <b>WebLM Normal Mode</b> The system is fully licensed. WebLM has been configured and there are enough licenses available to license all of the configured features.</li> <li>• <b>WebLM Error Mode</b> Action is required to correct the License Mode. Refer to the License Status column and the Error List section at the bottom of the screen to determine why the system is in License Error Mode. A 30-day grace period provides access to the capacities and features of the installed license when the system is in License Error Mode.</li> <li>• <b>WebLM Restricted Mode</b> When the system is in License Error Mode, if the problem is not resolved with the 30-day grace period, the system will enter License Restricted Mode. When in this mode, configuration changes are blocked, except for fixing the licensing errors. If a feature license cannot be acquired from the WebLM server, the feature will not function.</li> </ul>			
	Type	Mode	WebLM Configured	Virtual License and Grace Period (30 days)
	Nodal	Normal	No	No

*Table continues...*

Name	Description																				
	<table border="1"> <tr> <td>WebLM</td> <td>Server Error</td> <td>Yes</td> <td>No</td> </tr> <tr> <td>WebLM</td> <td>Configuration Error</td> <td>Yes</td> <td>No</td> </tr> <tr> <td>WebLM</td> <td>Normal</td> <td>Yes</td> <td>No</td> </tr> <tr> <td>WebLM</td> <td>Error</td> <td>Yes</td> <td>Yes</td> </tr> <tr> <td>WebLM</td> <td>Restricted</td> <td>Yes</td> <td>No</td> </tr> </table>	WebLM	Server Error	Yes	No	WebLM	Configuration Error	Yes	No	WebLM	Normal	Yes	No	WebLM	Error	Yes	Yes	WebLM	Restricted	Yes	No
WebLM	Server Error	Yes	No																		
WebLM	Configuration Error	Yes	No																		
WebLM	Normal	Yes	No																		
WebLM	Error	Yes	Yes																		
WebLM	Restricted	Yes	No																		
<b>Licensed Version</b>	Indicates the software version the system is currently licensed for.																				
<b>PLDS Host ID</b>	The ID used when generating PLDS nodal license files. Not used with WebLM licensing. WebLM licensing uses the host ID of the WebLM server.																				
<b>PLDS File Status</b>	If a PLDS nodal license file is loaded, this field indicates if the file is valid or not.																				
<b>Select Licensing</b>	Indicates that the system has a valid Select license.																				
<b>Feature</b>	Identifies the licenses installed on the system.																				
<b>Key</b>	This is the license key string supplied. It is a unique value based on the feature being licensed and the either the system's <b>Dongle Serial Number</b> or <b>System Identification</b> depending on the type of system.  Not applicable when using PLDS or WebLM licensing. This field is not displayed if there are no ADI licenses.																				
<b>Instance</b>	For information only. Some licenses enable a number of port, channels or users. When that is the case, the number of such is indicated here. Multiple licenses for the same feature are usually cumulative.																				
<b>Status</b>	For information only. This field indicates the current validation status of the license key. <ul style="list-style-type: none"> <li>• <b>Unknown</b> This status is shown for licenses that have just been added to the configuration shown in Manager. Once the configuration has been sent back to the system and then reloaded, the status will change to one of those below.</li> <li>• <b>Valid</b>: The license is valid.</li> <li>• <b>Invalid</b>: The license was not recognized. It did not match the PLDS host ID.</li> <li>• <b>Dormant</b>: The license is valid but is conditional on some other pre-requisite licenses.</li> <li>• <b>Obsolete</b>: The license is valid but is one no longer used by the level of software running on the system.</li> </ul>																				
<b>Expiry Date</b>	For information only. Trial licenses can be set to expire within a set period from their issue. The expiry date is shown here.																				
<b>Source</b>	The source of the license file. The options are: <ul style="list-style-type: none"> <li>• <b>ADI Nodal</b>: ADI licenses added locally to the system. This may appear on upgraded systems.</li> <li>• <b>PLDS Nodal</b>: PLDS licenses added locally to the system.</li> <li>• <b>WebLM</b>: Licenses obtained from the WebLM server.</li> <li>• <b>Virtual</b>: Licenses created by the system. This may appear on upgraded systems.</li> <li>• <b>Virtual Grace</b>: Licenses created by the system while in WebLM error mode.</li> </ul>																				

Additional Configuration Information

Click **PLDS License > Send To IP Office > OK** to open the **Select PLDS License File** dialog from where you can upload a PLDS license to IP Office. You can browse to a location on your system and select a file to upload.

Select an existing license and click **PLDS License > Delete From IP Office > OK** to delete the selected license.

**Related links**

[License](#) on page 531

## Remote Server

Navigation: **License | Remote Server**

This tab is used for:

- IP500 V2 systems in a Enterprise Branch deployments which are using WebLM licensing
- Server Edition systems to specify which method of centralized licensing is used.

The **Reserved Licenses** setting is mergeable. The remaining settings are not mergeable. Changes to these settings requires a reboot of the system.

The following field two fields control which source the system uses for its licenses. The field shown depends on the type of system:

Field	Description
<b>Licence Source</b>	<p>Default = WebLM.</p> <p>This field is available on Server Edition systems. All systems in the network must use the same source for licensing. The options are:</p> <ul style="list-style-type: none"> <li>• <b>WebLM:</b> Licenses are obtained from the WebLM service. The PLDS license file is uploaded to the WebLM service. All servers in the network make license reservation requests to the WebLM service. On Server Edition systems, a <b>Deploy</b> button appears when you select <b>WebLM</b> as <b>License Source</b>. Click the <b>Deploy</b> button to browse and select a license file to deploy.</li> <li>• <b>Local / Primary Server:</b> The PLDS license file is uploaded to the IP Office service, not WebLM. Depending on the particular license, some are obtained by reservation requests to the primary server, others are obtained from the server's own license file.</li> </ul>
<b>Enable Remote Server</b>	<p>Default = Off.</p> <p>This field is available on non-Server Edition IP500 V2 systems. The options are:</p> <ul style="list-style-type: none"> <li>• If disabled, the system is licensed locally by uploading a license file to the system.</li> <li>• If enabled, the system uses licenses requested from a remote WebLM server. This option is only supported for systems in a branch enterprise supported via Avaya System Manager.</li> </ul>

The additional fields displayed depend on the license source selection above:

### Local/Primary Server Licensed Server Settings

Field	Description
<b>License Server IP Address</b>	<p>Default = 127.0.0.1 on Primary. On Secondary and expansion systems, the default is the Primary IP address.</p> <p>This field is available when the <b>License Source</b> is set to <b>Local Primary Server</b>. This field contains the IP address of the Server Edition Primary server.</p>

### WebLM Licensed Primary Server Settings

Field	Description
<b>Domain Name (URL)</b>	<p>Default = Blank for IP500 V2 systems and for Server Edition Primary hosted deployments. For Server Edition, the IP address of the Primary Server.</p> <ul style="list-style-type: none"> <li>For Enterprise Branch deployments, the domain name or IP address of the WebLM server or the domain name of System Manager if the system is under System Manager control.</li> <li>For Server Edition deployments, the domain name or IP address of the Primary Server.</li> <li>For Server Edition hosted deployments, the domain name of the WebLM server.</li> </ul> <p>The format can be the FQDN or the IP address prefixed with https://.</p>
<b>Path</b>	<p>Default = WebLM/LicenseServer.</p> <p>The path on the web server of the WebLM resource.</p>
<b>Port Number</b>	<p>Default = 52233.</p> <p>The port number of the WebLM server.</p>
<b>WebLM Client ID</b>	An ID based on MAC address of the system. This is a read only field used by the WebLM server to identify the system.
<b>WebLM Node ID</b>	An ID based on MAC address and hostname of the system. This is a read only field used by the WebLM server to identify the system.

### WebLM Licensed Server (non-Primary) Settings

Field	Description
<b>Enable proxy via Primary IP Office line</b>	<p>Default = On.</p> <p>Available on Server Edition Secondary and Expansion systems.</p> <ul style="list-style-type: none"> <li>Enables retrieval of licenses from the WebLM server through the IP Office Line connection to the Server Edition Primary server.</li> <li>If the check box is cleared, the WebLM request is done directly to the WebLM server.</li> </ul> <p>Note that this field is not available if the node is not configured as a WebSocket client to the Server Edition Primary server.</p>
<b>Primary IP Address</b>	<p>Default = The IP address of the Server Edition Primary server.</p> <p>Available on Server Edition Secondary and Expansion systems when <b>Enable proxy via Primary IP Office line</b> is enabled</p>

*Table continues...*

Field	Description
<b>WebLM Client ID</b>	An ID based on MAC address of the system. This is a read only field used by the WebLM server to identify the system.
<b>WebLM Node ID</b>	An ID based on MAC address and hostname of the system. This is a read only field used by the WebLM server to identify the system.

### Reserved Licenses

These fields are used to reserve licenses from the license server, WebLM or, if using nodal licensing, the Primary server. There are two types of reservation field; manual and automatic.

- Manual fields can be used to set the number of licenses that the server should request from those available on the primary/WebLM server.
- Automatic fields are set to match other aspects of the server configuration, for example the number of configured power users. Note that these values may not change until after the configuration is saved and then reloaded.

<b>WebLM Reserved Licenses — Manual</b>	<b>Primary Server</b>	<b>Secondary Server</b>	<b>Expansion (Linux)</b>	<b>Expansion (IP500 V2)</b>
SIP Trunk Sessions	Yes	Yes	Yes	Yes
SM Trunk Sessions	Yes	Yes	Yes	Yes
Voicemail Pro Ports	Yes	Yes	-	-
VMPro Recordings Administrators	Yes	Yes	-	-
VMPro TTS Professional	Yes	Yes	-	-
Wave Users	-	-	-	Yes
CTI Link Pro	Yes	Yes	Yes	Yes
UMS Web Services	Yes	Yes	Yes	Yes
MAC Softphones	Yes	Yes	Yes	Yes
Avaya Contact Center Select	Yes	Yes	-	-
Third Party Recorder	Yes	Yes	-	-
VM Media Manager	Yes	Yes	Yes	-
Customer Service Supervisor	Yes	Yes	Yes	Yes
Customer Service Agent	Yes	Yes	Yes	Yes

<b>Nodal Reserved Licenses — Manual</b>	<b>Primary Server</b>	<b>Secondary Server</b>	<b>Expansion (Linux)</b>	<b>Expansion (IP500 V2)</b>
SIP Trunk Sessions	Yes	Yes	Yes	Yes



WebLM/Nodal Reserved Licenses — Automatic	Primary Server	Secondary Server	Expansion (Linux)	Expansion (IP500 V2)
Server Edition	Yes	Yes	Yes	Yes
Avaya IP Endpoints	Yes	Yes	Yes	Yes
3rd Party IP Endpoints	Yes	Yes	Yes	Yes
Receptionist	Yes	Yes	Yes	Yes
Office Worker	Yes	Yes	Yes	Yes
Power User	Yes	Yes	Yes	Yes
Avaya Softphone	Yes	Yes	Yes	Yes
Web Collaboration	Yes	Yes	Yes	Yes
Universal PRI Additional Channels	-	-	-	Yes
IPSec Tunneling	-	-	-	Yes

### Related links

[License](#) on page 531

---

## Tunnel



Tunneling allows additional security to be applied to IP data traffic. This is useful when sites across an unsecure network such as the public internet. The system supports two methods of tunneling, L2TP and IPSec. Once a tunnel is created, it can be used as the destination for selected IP traffic in the IP Route table.

The use of tunnels is not supported by Linux based systems. On other systems, two types of tunneling are supported.

### L2TP:

Layer 2 Tunneling Protocol PPP (Point to Point Protocol) authentication normally takes place between directly connected routing devices. For example when connecting to the internet, authentication is between the customer router and the internet service provider's equipment. L2TP allows additional authentication to be performed between the routers at each end of the connection regardless of any intermediate network routers. The use of L2TP does not require a license.

### IPSec:

IPSec allows data between two locations to be secured using various methods of sender authentication and or data encryption. The use of IPSec requires entry of an IPSec Tunneling license into the system at each end.

**Related links**

- [Configuration Mode Field Descriptions](#) on page 197
- [L2TP Tunnel](#) on page 538
- [IP Security Tunnel](#) on page 540

## L2TP Tunnel

**Related links**

- [Tunnel](#) on page 537
- [L2PT Tunnel](#) on page 538
- [L2TP](#) on page 539
- [L2TP PPP](#) on page 540

## L2PT Tunnel

Navigation: **Tunnel | Tunnel (L2TP)**

**Additional configuration information**

This type of configuration record can be saved as a template and new records created from a template. See [Working with Templates](#) on page 600.

**Configuration settings**

These settings are not mergeable. Changes to these settings will require a reboot of the system.

Field	Description
<b>Name</b>	Default = Blank. A unique name for the tunnel. Once the tunnel is created, the name can be selected as a destination in the IP Route table.
<b>Local Configuration</b> The account name and password is used to set the PPP authentication parameters.	
<b>Local Account Name</b>	The local user name used in outgoing authentication.
<b>Local Account Password/Confirm Password</b>	The local user password. Used during authentication.
<b>Local IP Address</b>	The source IP address to use when originating an L2TP tunnel. By default (un-configured), the system uses the IP address of the interface on which the tunnel is to be established as the source address of tunnel.

*Table continues...*

Field	Description
<b>Remote Configuration</b>	
The account name and password is used to set the PPP authentication parameters.	
<b>Remote Account Name</b>	The remote user name that is expected for the authentication of the peer.
<b>Remote Account Password/ Confirm Password</b>	The password for the remote user. Used during authentication.
<b>Remote IP Address</b>	The IP address of the remote L2TP peer or the local VPN line IP address or the WAN IP address.
<b>Minimum Call Time (Mins)</b>	Default = 60 minutes. Range = 1 to 999. The minimum time that the tunnel will remain active.
<b>Forward Multicast Messages</b>	Default = On Allow the tunnel to carry multicast messages when enabled.
<b>Encrypted Password</b>	Default = Off When enabled, the CHAP protocol is used to authenticate the incoming peer.

**Related links**

[L2TP Tunnel](#) on page 538

**L2TP**

Navigation: **Tunnel | L2TP**

These settings are not mergeable. Changes to these settings will require a reboot of the system.

Field	Description
<b>Shared Secret/ Confirm Password</b>	User setting used for authentication. Must be matched at both ends of the tunnel. This password is separate from the PPP authentication parameters defined on the L2TP Tunnel tab.
<b>Total Control Retransmission Interval</b>	Default = 0. Range = 0 to 65535. Time delay before retransmission.
<b>Receive Window Size</b>	Default = 4. Range = 0 to 65535. The number of unacknowledged packets allowed.
<b>Sequence numbers on Data Channel</b>	Default = On When on, adds sequence numbers to L2TP packets.
<b>Add checksum on UDP packets</b>	Default = On. When on, uses checksums to verify L2TP packets.

*Table continues...*

Field	Description
<b>Use Hiding</b>	Default = Off When on, encrypts the tunnel's control channel.

**Related links**

[L2TP Tunnel](#) on page 538

**L2TP PPP**

Navigation: **Tunnel | PPP (L2TP)**

These settings are not mergeable. Changes to these settings will require a reboot of the system.

Field	Description
<b>CHAP Challenge Interval (secs)</b>	Default = 0 (Disabled). Range = 0 to 99999 seconds. Sets the period between CHAP challenges. Blank or 0 disables repeated challenges. Some software (such as Windows 95 DUN) does not support repeated challenges.
<b>Header Compression</b>	Default = None Select header compression. Options are: IPHC and/or VJ.
<b>PPP Compression Mode</b>	Default = MPPC Select the compression mode for the tunnel connection. Options are: Disable, StaLZS or MPPC.
<b>Multilink/QoS</b>	Default = Off Enable the use of Multilink protocol (MPPC) on the link.
<b>Incoming traffic does not keep link up</b>	Default = On When enabled, the link is not kept up when the only traffic is incoming traffic.
<b>LCP Echo Timeout (msecs)</b>	Default = 6. Range = 0 to 99999 milliseconds. When a PPP link is established, it is normal for each end to send echo packets to verify that the link is still connected. This field defines the time between LCP echo packets. Four missed responses in a row will cause the link to terminate.

**Related links**

[L2TP Tunnel](#) on page 538

**IP Security Tunnel**

**Related links**

[Tunnel](#) on page 537

[IPSec Main](#) on page 541

[Tunnel | IKE Policies \(IPSec\)](#) on page 541

[IPSec Policies](#) on page 542

## IPSec Main

Navigation: **Tunnel | Main (IPSec)**

For Server Edition, this type of configuration record can be saved as a template and new records created from a template.

These settings are not mergeable. Changes to these settings will require a reboot of the system.

Field	Description
<b>Name</b>	Default = Blank. A unique name for the tunnel. Once the tunnel is created, the name can be selected as a destination for traffic in the IP Route table.
<b>Local Configuration</b>	
The IP Address and IP Mask are used in conjunction with each other to configure and set the conditions for this Security Association (SA) with regard to inbound and outbound IP packets.	
<b>IP Address</b>	The IP address or sub-net for the start of the tunnel.
<b>IP Mask</b>	The IP mask for the above address.
<b>Tunnel Endpoint IP Address</b>	The local IP address to be used to establish the SA to the remote peer. If left un-configured, the system will use the IP address of the local interface on which the tunnel is to be configured.
<b>Remote Configuration</b>	
The IP Address and IP Mask are used in conjunction with each other to configure and set the conditions for this Security Association (SA) with regard to inbound and outbound IP packets.	
<b>IP Address</b>	The IP address or sub-net for the end of the tunnel.
<b>IP Mask</b>	The IP mask for the above address.
<b>Tunnel Endpoint IP Address</b>	The IP address of the peer to which a SA must be established before the specified local and remote addresses can be forwarded.

### Related links

[IP Security Tunnel](#) on page 540

## Tunnel | IKE Policies (IPSec)

Navigation: **Tunnel | IKE Policies (IPSec)**

These settings are not mergeable. Changes to these settings will require a reboot of the system.

Field	Description
<b>Shared Secret/ Confirm Password</b>	The password used for authentication. This must be matched at both ends of the tunnel.
<b>Exchange Type</b>	Default = ID Prot Aggressive provides faster security setup but does not hide the ID's of the communicating devices. <b>ID Prot</b> is slower but hides the ID's of the communicating devices.

*Table continues...*

Field	Description
<b>Encryption</b>	Default = 3DES CBC Select the encryption method used by the tunnel. The option is: <ul style="list-style-type: none"> <li>• <b>3DES CBC</b></li> </ul>
<b>Authentication</b>	Default = SHA The method of password authentication. The option is: <ul style="list-style-type: none"> <li>• <b>SHA</b></li> </ul>
<b>DH Group</b>	Default = Group 1
<b>Life Type</b>	Default = KBytes Sets whether <b>Life</b> (below) is measured in seconds or kilobytes.
<b>Life</b>	Range = 0 to 99999999. Determines the period of time or the number of bytes after which the SA key is refreshed or re-calculated.

**Related links**

[IP Security Tunnel](#) on page 540

**IPSec Policies**

Navigation: **Tunnel | IKE Policies (IPSec)**

These settings are not mergeable. Changes to these settings will require a reboot of the system.

Field	Description
<b>Protocol</b>	Default = ESP The options are: <ul style="list-style-type: none"> <li>• <b>ESP</b> (Encapsulated Security Payload)</li> <li>• <b>AH</b> (Authentication Header, no encryption)</li> </ul>
<b>Encryption</b>	Default = DES3 Select the encryption method used by the tunnel. The option is: <ul style="list-style-type: none"> <li>• <b>DES3</b></li> </ul>
<b>Authentication</b>	Default = HMAC SHA The method of password authentication. The option is: <ul style="list-style-type: none"> <li>• <b>HMAC SHA</b></li> </ul>
<b>Life Type</b>	Default = KBytes Sets whether Life (below) is measured in seconds or kilobytes.
<b>Life</b>	Determines the period of time or the number of bytes after which the SA key is refreshed or re-calculated.

**Related links**

[IP Security Tunnel](#) on page 540

---

## Auto Attendant

These settings are used for embedded voicemail provided by the IP Office control unit. This is setup by adding an Avaya Embedded Voicemail memory card to the control unit and then selecting **Embedded Voicemail** as the **Voicemail Type**.

This tab and its settings are hidden unless the system has been configured to use Embedded Voicemail on the System | Voicemail tab.

For full details on configuration and operation of Embedded Voicemail auto-attendants refer to the IP Office Embedded Voicemail Installation Manual.

Up to 40 auto-attendant services can be configured.

Embedded voicemail services include auto-attendant, callers accessing mailboxes to leave or collect messages and announcements to callers waiting to be answered.

The IP500 V2 supports 2 simultaneous Embedded Voicemail calls by default but can be licensed for up to 6. The licensed limit applies to total number of callers leaving messages, collecting messages and or using an auto attendant.

In addition to basic mailbox functionality, Embedded Voicemail can also provide auto-attendant operation. Each auto attendant can use existing time profiles to select the greeting given to callers and then provide follow on actions relating to the key presses 0 to 9, \* and #.

**Time Profiles:**

Each auto attendant can use up to three existing time profiles, on each for Morning, Afternoon and Evening. These are used to decide which greeting is played to callers. They do not change the actions selectable by callers within the auto attendant. If the time profiles overlap or create gaps, then the order of precedence used is morning, afternoon, evening.

**Greetings:**

Four different greetings are used for each auto attendant. One for each time profile period. This is then always followed by the greeting for the auto-attendant actions. By default a number of system short codes are automatically created to allow the recording of these greetings from a system extension. See below.

**Actions:**

Separate actions can be defined for the DTMF keys 0 to 9, \* and #. Actions include transfer to a specified destination, transfer to another auto-attendant transfer to a user extension specified by the caller (dial by number) and replaying the greetings.

- The **Fax** action can be used to reroute fax calls when fax tone is detected by the auto-attendant.

- The **Dial by Name** action can be used to let callers specify the transfer destination.

### Short Codes:

Adding an auto attendant automatically adds a number of system short codes. These use the **Auto Attendant** short code feature. These short codes are used to provide dialing access to record the auto attendant greetings.

Four system short codes (**\*81XX**, **\*82XX**, **\*83XX** and **\*84XX**) are automatically added for use with all auto attendants, for the morning, afternoon, evening and menu options greetings respectively. These use a telephone number of the form "**AA:" N" . Y "** where **N** is the replaced with the auto attendant number dialed and **Y** is 1, 2, 3 or 4 for the morning, afternoon, evening or menu option greeting.

- An additional short code of the form (for example) **\*80XX/Auto Attendant/"AA:"N** can be added manual if internal dialed access to auto attendants is required.
- To add a short code to access a specific auto attendant, the name method should be used.
- For IP Office deployed in a Enterprise Branch environment, the short codes **\*800XX**, **\*801XX...\*809XX**, **\*850XX**, and **\*851XX** are automatically created for recording a Page prompt.

### Routing Calls to the Auto Attendant:

The telephone number format **AA:Name** can be used to route callers to an auto attendant. It can be used in the destination field of incoming call routes and telephone number field of short codes set to the Auto Attend feature.

### Related links

[Configuration Mode Field Descriptions](#) on page 197

[Auto Attendant](#) on page 544

[Actions](#) on page 546

---

## Auto Attendant

Navigation: **Auto Attendant | Auto Attendant**

These settings are used to define the name of the auto attendant service and the time profiles that should control which auto attendant greetings are played.

These settings are mergeable. Changes to these settings do not require a reboot of the system.

Field	Description
<b>Name</b>	Range = Up to 12 characters  This field sets the name for the auto-attendant service. External calls can be routed to the auto attendant by entering AA:Name in the destination field of an Incoming Call Route.

*Table continues...*



Field	Description
<b>Maximum Inactivity</b>	<p>Default = 8 seconds; Range = 1 to 20 seconds.</p> <p>This field sets how long after playing the prompts the Auto Attendant should wait for a valid key press. If exceeded, the caller is either transferred to the Fallback Extension set within the Incoming Call Route used for their call or else the caller is disconnected.</p>
<b>Enable Local Recording</b>	<p>Default = On.</p> <p>When off, use of short codes to record auto-attendant prompts is blocked. The short codes can still be used to playback the greetings.</p>
<b>Direct Dial-By-Number</b>	<p>Default = Off.</p> <p>This setting affects the operation of any key presses in the auto attendant menu set to use the <b>Dial By Number</b> action.</p> <p>If selected, the key press for the action is included in any following digits dialed by the caller for system extension matching. For example, if 2 is set in the actions to <b>Dial by Number</b>, a caller can dial 201 for extension 201.</p> <p>If not selected, the key press for the action is not included in any following digits dialed by the caller for system extension matching. For example, if 2 is set in the actions to <b>Dial by Number</b>, a caller must dial 2 and then 201 for extension 201.</p>
<b>Dial by Name Match Order</b>	<p>Default = First Name/Last Name.</p> <p>Determines the name order used for the Embedded Voicemail Dial by Name function. The options are:</p> <ul style="list-style-type: none"> <li>• <b>First then Last</b></li> <li>• <b>Last then First</b></li> </ul>
<b>AA Number</b>	<p>This number is assigned by the system and cannot be changed. It is used in conjunction with short codes to access the auto attendant service or to record auto attendant greetings.</p>

*Table continues...*

Field	Description
<b>Morning/ Afternoon/ Evening/Menu Options</b>	<p>Each auto-attendant can consist of three distinct time periods, defined by associated time profiles. A greeting can be recorded for each period. The appropriate greeting is played to callers and followed by the Menu Options greeting which should list the available actions. The options are:</p> <ul style="list-style-type: none"> <li>• <b>Time Profile</b> The time profile that defines each period of auto-attendant operation. When there are overlaps or gaps between time profiles, precedence is given in the order morning, afternoon and then evening.</li> <li>• <b>Short code</b> These fields indicate the system short codes automatically created to allow recording of the time profile greetings and the menu options prompt.</li> <li>• <b>Recording Name:</b> Default = Blank. Range = Up to 31 characters. This field appears next to the short code used for manually recording auto-attendant prompts. It is only used is using pre-recorded wav files as greeting rather than manually recording greetings using the indicated short codes. If used, note that the field is case sensitive and uses the name embedded within the wav file file header rather than the actual file name.</li> </ul> <p>This field can be used with all systems supporting Embedded Voicemail. The utility for converting .wav files to the correct format is provided with Manager and can be launched via File   Advanced   LVM Greeting Utility. Files then need to be manually transferred to the Embedded Voicemail memory card. For full details refer to the IP Office Embedded Voicemail Installation manual.</p>

**Related links**

[Auto Attendant](#) on page 543

---

## Actions

Navigation: **Auto Attendant | Actions**

This tab defines the actions available to callers dependant on which DTMF key they press. To change an action, select the appropriate row and click **Edit**. When the key is configured as required click **OK**.

These settings are mergeable. Changes to these settings do not require a reboot of the system.

Field	Description
<b>Key</b>	<p>The standard telephone dial pad keys, 0 to 9 plus * and #.</p> <p>The option <b>Fax</b> can be used for a transfer to the required fax destination and will then be triggered by fax tone detection. If left as <b>Not Defined</b>, fax calls will follow the incoming call routes fallback settings once the auto-attendant Maximum Inactivity Time set on the Auto Attendant   Auto Attendant tab is reached.</p>
<b>Action</b>	<p>The following actions can be assigned to each key.</p>

*Table continues...*

Field	Description
<b>Centrex Transfer</b>	Used to transfer the incoming call to an external telephone number defined in the <b>Transfer Number</b> field.  Only supported for calls on Centrex analog trunks.  This option is only supported with Embedded Voicemail.
<b>Dial by Name</b>	Callers are asked to dial the name of the user they require and then press #. The recorded name prompts of matching users are then played back for the caller to make a selection. The name order used is set by the <b>Dial by Name Match Order</b> setting on the Auto Attendant tab. Note the name used is the user's <b>Full Name</b> if set, otherwise their <b>User Name</b> is used. Users without a recorded name prompt or set to <b>Exclude From Directory</b> are not included. For Embedded Voicemail in IP Office mode, users can record their name by accessing their mailbox and dialing *05. For Embedded Voicemail in Intuity mode, users are prompted to record their name when they access their mailbox.
<b>Dial By Number</b>	This option allows callers with DTMF phones to dial the extension number of the user they require. No destination is set for this option. The prompt for using this option should be included in the auto attendant Menu Options greeting. A uniform length of extension number is required for all users and hunt group numbers. The operation of this action is affected by the auto attendant's Direct Dial-by-Number setting.
<b>Normal Transfer</b>	Can be used with or without a <b>Destination</b> set. When the <b>Destination</b> is not set, this action behaves as a <b>Dial By Number</b> action. With the <b>Destination</b> is set, this action waits for a connection before transferring the call. Callers can hear Music on Hold. Announcements are not heard.
<b>Not Defined</b>	The corresponding key takes no action.
<b>Park &amp; Page</b>	The Park & Page feature is supported when the system <b>Voicemail Type</b> is designated as <b>Embedded Voicemail</b> or <b>Voicemail Pro</b> . Park & Page is also supported on systems where <b>Modular Messaging over SIP</b> is configured as the central voicemail system and the local <b>Embedded Voicemail</b> provides auto attendant operation. The Park & Page feature is an option in user mailboxes where a key is configured with the Park & Page feature. When an incoming call is answered by the voicemail system and the caller dials the DTMF digit for which Park & Page is configured, the caller hears the Park & Page prompt. IP Office parks the call and sends a page to the designated extension or hunt group. When Park & Page is selected in the <b>Action</b> drop-down box, the following fields appear: <ul style="list-style-type: none"> <li>• <b>Park Slot Prefix</b> – the desired Park Slot prefix number. Maximum is 8 digits. A 0-9 will be added to this prefix to form a complete Park Slot.</li> <li>• <b>Retry count</b> – number of page retries; the range is 0 to 5.</li> <li>• <b>Retry timeout</b> – provided in the format M:SS (minute:seconds). The range can be set in 15-second increments. The minimum setting is 15 seconds and the maximum setting is 5 minutes. The default setting is 15 seconds.</li> <li>• <b>Page prompt</b> – short code to record the page prompt or upload the recorded prompt. (Prompt can be uploaded to the SD card in the same way the AA prompts are).</li> </ul>
<b>Replay Menu Greeting</b>	Replay the auto-attendant greetings again.

*Table continues...*

Field	Description
<b>Transfer</b>	Transfer the call to the selected destination. This is an unsupervised transfer, if the caller is not answered they will be handled as per a direct call to that number.
<b>Transfer to Attendant</b>	This action can be used to transfer calls to another existing auto attendant.
<b>Destination</b>	<p>Sets the destination for the action.</p> <p>Destination can be a user, a hunt group or a short code.</p> <p>If the destination field is left blank, callers can dial the user extension number that they require. Note however that no prompt is provided for this option so it should be included in the auto attendant Menu Options greeting.</p>
<b>Consent Directive</b>	<p>This field is used to control the addition of a consent value to the system's SMDR output and CTI call logging outputs. The intention is to allow the creation of auto-attendants where having been prompts for consent to some issue, the caller's response is included in the system call logs. It can be set to the following:</p> <ul style="list-style-type: none"> <li>• Not applicable: Set the consent value in the logging outputs to 0.</li> <li>• Consent Denied: Set the consent value in the logging outputs to 6.</li> <li>• Consent Given: Set the consent value in the logging outputs to 1.</li> </ul>

**Related links**

[Auto Attendant](#) on page 543

## Authorization Codes

Navigation: **Authorization Codes**

 **Note:**

In release 9.1, authorization codes can no longer be associated with User Rights. If an authorization code was configured in relationship with User Rights in an earlier release configuration, this authorization code will be lost during upgrade. The administrator must re-configure the authorization code, after upgrade. The authorization code must be associated with a user.

Authorization codes are enabled by default.

Each authorization code is associated with a particular user. The user can then dial numbers which are set to trigger forced authorization code entry. Once a code is entered, the short code settings of the user with which the code is associated are used to completed the call.

This can be used to allow authorized users to make otherwise restricted calls from any extension without first having to log in to that extension and then log out after the call. Valid/invalid authorization code entry can be recorded in the SMDR output.

The recommended limit for authorization codes is 1000 entries.

These settings are mergeable. Changes to these settings do not require a reboot of the system.

Field	Description
<b>Authorization Code</b>	Range = Up to 12 digits. The digits used for the authorization code. Each code must be unique. Wildcards are not usable with authorization codes.
<b>User</b>	This field is used to select a user with which the authorization code is associated. The authorization code can then be used to authorize calls made by that user.

**Related links**

[Configuration Mode Field Descriptions](#) on page 197

---

## User Rights

**Additional configuration information**

This section provides the User Rights field descriptions. For additional configuration information, see [Configuring User Rights](#) on page 664.

User Rights act as templates for selected user settings. The settings of a user rights template are applied to all users associated with that template. The use of a template can also be controlled by a time profile to set when the template is used for a particular user.

**Related links**

[Configuration Mode Field Descriptions](#) on page 197

---

## User

Navigation: **User Rights | User**

Used to set and lock various user settings.

These settings are mergeable. Changes to these settings do not require a reboot of the system.

For a Server Edition network, these settings can be configured at the network level and are then automatically replicated in the configuration of all systems in the network. They can only be seen and edited at the individual system configuration level if record consolidation is switched off.

Field	Description
<b>Name</b>	The name for the user rights . This must be set in order to allow the user rights to be selected within the User Rights drop down list on the User   User tab of individual users.
<b>Application Servers Group</b>	Default = Off. Set to On if the IP Office system is deployed in an IP Office Contact Center solution or an Avaya Contact Center Select solution. Only one user rights record can be configured to be the Application Servers Group. If it is set on any one group then the control is disabled on all other groups.

*Table continues...*

Field	Description
<b>Locale</b>	Default = Blank Sets and locks the language used for voicemail prompts to the user, assuming the language is available on the voicemail server. On a digital extension it also controls the display language used for messages from the system to the phone. See <i>Avaya IP Office™ Platform Locale Settings</i> .
<b>Priority</b>	Default = 5, Range 1 (Lowest) to 5 (Highest) Sets and locks the user's priority setting for least cost routing.
<b>Do Not Disturb</b>	Default = Off Sets and locks the user's DND status setting.

---

## Short Codes

Navigation: **User Rights | Short Codes**

Used to set and lock the user's short code set. The tab operates in the same way as the **User | Short Codes** tab. User and User Rights short codes are only applied to numbers dialed by that user. For example they are not applied to calls forwarded via the user.

 **Warning:**

User dialing of emergency numbers must not be blocked. If short codes are edited, the users ability to dial emergency numbers must be tested and maintained.

These settings are mergeable. Changes to these settings do not require a reboot of the system.

For a Server Edition network, these settings can be configured at the network level and are then automatically replicated in the configuration of all systems in the network. They can only be seen and edited at the individual system configuration level if record consolidation is switched off.

Short codes can be added and edited using the **Add**, **Remove** and **Edit** buttons. Alternatively you can right-click on the list of existing short code to add and edit short codes.

---

## Button Programming

Navigation: **User Rights | Button Programming**

This tab is used to set and lock the user's programmable button set. When locked, the user cannot use **Admin** or **Admin1** buttons on their phone to override any button set by their user rights.

Buttons not set through the user rights can be set through the user's own settings. When **Apply user rights value** is selected, the tab operates in the same manner as the **User | Button Programming** tab.

These settings are mergeable. Changes to these settings do not require a reboot of the system.

For a Server Edition network, these settings can be configured at the network level and are then automatically replicated in the configuration of all systems in the network. They can only be seen and edited at the individual system configuration level if record consolidation is switched off.

## Adding Blank Buttons

There are scenarios where users are able to program their own buttons but you may want to force certain buttons to be blank. This can be done through the user's associated **User Rights** as follows:

1. Assign the action **Emulation | Inspect** to the button. This action has no specific function. Enter some spaces as the button label.
2. When pressed by the user, this button will not perform any action. However it cannot be overridden by the user.

---

## Telephony

Navigation: **User Rights | Telephony**

Allows various user telephony settings to be set and locked. These match settings found on the **User | Telephony** tab.

## Call Settings

Navigation: **User Rights | Telephony | Call Settings**

### Additional configuration information

For additional information on ring tones, see [Ring Tones](#) on page 619.

### Configuration settings

For a Server Edition network, these settings can be configured at the network level and are then automatically replicated in the configuration of all systems in the network. They can only be seen and edited at the individual system configuration level if record consolidation is switched off.

These settings are mergeable. Changes to these settings do not require a reboot of the system.

Field	Description
<b>No Answer Time</b>	Default = Blank (Use system setting). Range = 6 to 99999 seconds. Sets how long a call rings the user before following forwarded on no answer if set or going to voicemail. Leave blank to use the system default setting.
<b>Transfer return Time (secs)</b>	Default = Blank (Off), Range 1 to 99999 seconds. Sets the delay after which any call transferred by the user, which remains unanswered, should return to the user if possible.
<b>Wrap up Time (secs)</b>	Default = 2 seconds, Range 0 to 99999 seconds. Specifies the amount of time after ending one call before another call can ring. You may wish to increase this in a "call center" environment where users may need time to log call details before taking the next call. It is recommended that this option is not set to less than the default of 2 seconds. 0 is used for immediate ringing.

*Table continues...*

Field	Description
<b>Call waiting on/ Enable call waiting</b>	<p>Default = Off</p> <p>For users on phones without appearance buttons, if the user is on a call and a second call arrives for them, an audio tone can be given in the speech path to indicate a waiting call (the call waiting tone varies according to locale). The waiting caller hears ringing rather than receiving busy. There can only be one waiting call, any further calls receive normal busy treatment. If the call waiting is not answered within the no answer time, it follows forward on no answer or goes to voicemail as appropriate. User call waiting is not used for users on phones with multiple call appearance buttons.</p>
<b>Busy on held/ Enable busy on Held</b>	<p>Default = Off</p> <p>If on, when the user has a call on hold, new calls receive busy tone (ringing for incoming analog call) or are diverted to voicemail if enabled, rather than ringing the user. Note this overrides call waiting when the user has a call on hold. Not supported (should be set to off) for users with call appearance buttons.</p>

## Supervisor Settings

Navigation: **User Rights | Telephony | Supervisor Settings**

### Additional configuration information

Off-Switch Transfer Restriction

Call Barring

### Configuration settings

These settings relate to user features normally only adjusted by the user's supervisor.

These settings are mergeable. Changes to these settings do not require a reboot of the system.

For a Server Edition network, these settings can be configured at the network level and are then automatically replicated in the configuration of all systems in the network. They can only be seen and edited at the individual system configuration level if record consolidation is switched off.

Field	Description
<b>Can Intrude</b>	<p>Default = Off</p> <p>Check this option if the User can interrupt other user's calls. This setting and the setting below are used to control the use of the following short code and button features:</p> <ul style="list-style-type: none"> <li>• Call Intrude</li> <li>• Call Listen</li> <li>• Call Steal</li> <li>• Dial Inclusion</li> </ul>
<b>Cannot be Intruded</b>	<p>Default = On</p> <p>If checked, this user's calls cannot be interrupted or acquired. In addition to the features listed above, this setting also affects whether other users can use their appearance buttons to bridge into a call to which this user has been the longest present user.</p>

*Table continues...*



Field	Description
<b>Deny Auto Intercom Calls</b>	Default = Off. When enabled, any automatic intercom calls to the user's extension are automatically turned into normal calls.
<b>Force Login</b>	Default = Off If checked, the user must log in using their Login Code to use an extension. For example, if Force Login is ticked for User A and user B has logged into A's phone, after B logs off A must log back. If Force Login was not ticked, A would be automatically logged back in.
<b>Force Account Code</b>	Default = Off If checked, the user must enter a valid account code to make an external call.
<b>Inhibit Off-Switch Forward/Transfer</b>	: Default = Off When enabled, this setting stops the user from transferring or forwarding calls externally. Note that all user can be barred from forwarding or transferring calls externally by the <b>System   Telephony   Telephony   Inhibit Off-Switch Forward/Transfers</b> setting.
<b>Outgoing Call Bar</b>	Default = Off When set, bars the user from making external calls.
<b>Coverage Group</b>	Default = <None> If a group is selected, the system will not use voicemail to answer the users unanswered calls. Instead the call will continue ringing until either answered or the caller disconnects. For external calls, after the users no answer time, the call is also presented to the users who are members of the selected Coverage Group. For further details refer to Coverage Groups.
<b>ICR Agent</b>	Applicable for Integrated Contact Reporter Default = Off Enable to configure user right members as ICR agents. Any user configured to use the user right becomes an ICR agent. If enabled, it also activates the After Call Work related fields. <b>* Note:</b> Integrated Contact Reporter is not supported in IP Office Release 11.0.
<b>Automatic After Call Work</b>	Applicable for Integrated Contact Reporter Default = Off If enabled, all ICR agents of the user right go into After Call Work (ACW) at the end of an ICR and non-ICR hunt group call to indicate that they are busy with post-call processing activity. During the ACW state, they are not sent any hunt group calls. For more information about configuring ACW, see <i>Administering Avaya IP Office™ Platform Integrated Contact Reporter</i> . <b>* Note:</b> Integrated Contact Reporter is not supported in IP Office Release 11.0.

Table continues...

Field	Description
<b>Can Control after Call Work</b>	<p>Applicable for Integrated Contact Reporter</p> <p>Default = Off</p> <p>If enabled, the ICR agents in the user right can extend the currently active After Call Work time indefinitely.</p> <p><b>* Note:</b> Integrated Contact Reporter is not supported in IP Office Release 11.0.</p>
<b>After Call Work Time</b>	<p>Applicable for Integrated Contact Reporter</p> <p>Default = The value in this field is populated from the <b>Default After Call Work Time</b> field located at <b>System   Contact Center</b>.</p> <p>The time after a call when an agent is busy and unable to deal with hunt group calls. Change the value if you want to specify ACW time for this all ICR agents in the user right to be different from the system default.</p> <p><b>* Note:</b> Integrated Contact Reporter is not supported in IP Office Release 11.0.</p>

## Multi-line Options

Navigation: **User Rights | Telephony | Multi-line Options**

### Additional configuration information

For additional configuration information, see [Appearance Button Operation](#) on page 1079.

### Configuration settings

Multi-line options are applied to a user's phone when the user is using an Avaya phones which supports appearance buttons (call appearance, line appearance, bridged and call coverage).

For a Server Edition network, these settings can be configured at the network level and are then automatically replicated in the configuration of all systems in the network. They can only be seen and edited at the individual system configuration level if record consolidation is switched off.

These settings are mergeable. Changes to these settings do not require a reboot of the system.

Field	Description
<b>Individual Coverage Time (secs)</b>	<p>Default = 10 seconds, Range 1 to 99999 seconds.</p> <p>This function sets how long the phone will ring at your extension before also alerting at any call coverage users. This time setting should not be equal to or greater than the No Answer Time.</p>

## Call Log

Navigation: **User Rights | Telephony | Call Log**



The system can store a centralized call log for users. Each users' centralized call log can contain up to 30 call records for user calls. When this limit is reached, each new call records replaces the oldest previous record.

On Avaya phones with a fixed **Call Log** or **History** button (1400, 1600, 9500 and 9600 Series), that button can be used to display the user's centralized call log. The centralized call log is also used for M-Series and T-Series phone. The user can use the call log to make calls or to store as a personal speed dial. They can also edit the call log to remove records. The same call log is also used if the user logs into one-X Portal for IP Office.

The centralized call log moves with the user if they log on and off from different phones. This includes if they hot desk within a network.

These settings are mergeable. Changes to these settings do not require a reboot of the system.

For a Server Edition network, these settings can be configured at the network level and are then automatically replicated in the configuration of all systems in the network. They can only be seen and edited at the individual system configuration level if record consolidation is switched off.

Field	Description
<b>Centralized Call Log</b>	<p>Default = System Default (On) </p> <p>This setting allows the use of centralized call logging to be enabled or disabled on a per user basis. The default is to match the system setting <b>System   Telephony   Call Log   Default Centralized Call Log On</b>.</p> <p>The other options are <b>On</b> or <b>Off</b> for the individual user. If off is selected, the call log shown on the users phone is the local call log stored by the phone.</p>
<b>Delete records after (hours:minutes)</b>	<p>Default = 00:00 (Never). </p> <p>If a time period is set, records in the user's call log are automatically deleted after this period.</p>
<b>Groups</b>	<p>Default = System Default (On). </p> <p>This section contains a list of hunt groups on the system. If the system setting <b>System   Telephony   Call Log   Log Missed Huntgroup Calls</b> has been enabled, then missed calls for those groups selected are shown as part of the users call log. The missed calls are any missed calls for the hunt group, not just group calls presented to the user and not answered by them.</p>

---

## User Rights Membership

Navigation: **User Rights | User Rights Membership**

The tabs display the users associated with the user rights and allows these to be changed.

These settings are mergeable. Changes to these settings do not require a reboot of the system.

For a Server Edition network, these settings can be configured at the network level and are then automatically replicated in the configuration of all systems in the network. They can only be seen and edited at the individual system configuration level if record consolidation is switched off.

Field	Description
<b>Members of this User Rights</b>	This tab indicates those users associated with the user rights. If the user has an associated Working hours time profile, their association to the user rights applies only during the periods defined by the time profile. If the user does not have an associated Working hours time profile, they are associated with the user rights at all times.
<b>Members when out of service</b>	This tab indicates those users associated with the user rights outside the time periods defined by their Working hours time profile. The Members when out of service tab is not populated unless there are time profiles available within the configuration.

## Voicemail

Navigation: **User Rights | Voicemail**

Display the users associated with the user rights and allows these to be changed.

These settings are mergeable. Changes to these settings do not require a reboot of the system.

For a Server Edition network, these settings can be configured at the network level and are then automatically replicated in the configuration of all systems in the network. They can only be seen and edited at the individual system configuration level if record consolidation is switched off.

Field	Description
<b>Voicemail On</b>	Default = On  When on, the mailbox is used by the system to answer the user's unanswered calls or calls when the user's extension returns busy. Note that selecting off does not disable use of the user's mailbox. Messages can still be forward to their mailbox and recordings can be placed in it. The mailbox can also still be accessed to collect messages.
<b>Voicemail Ringback</b>	Default = Off  When enabled and a new message has been received, the voicemail server calls the user's extension to attempt to deliver the message each time the telephone is put down. Voicemail will not ring the extension more than once every 30 seconds.

### DTMF Breakout

When a caller is directed to voicemail to leave a message, they can be given the option to be transferred to a different extension. The greeting message needs to be recorded telling the caller the options available. The extension numbers that they can be transferred to are entered in the fields below. These system default values can be set for these numbers and are used unless a different number is set within these user settings.

The Park & Page feature is supported when the system voicemail type is configured as **Embedded Voicemail** or **Voicemail Pro**. Park & Page is also supported on systems where Avaya Aura Messaging, Modular Messaging over SIP, or CallPilot (for Enterprise Branch with CS 1000 deployments) is configured as the central voice mail system and the local Embedded Voicemail or Voicemail Pro provides auto attendant operation. The Park & Page feature allows a call to be parked while a page is made to a hunt group or extension. This feature can be configured for Breakout DTMF 0, Breakout DTMF 2, or Breakout DTMF 3.

*Table continues...*

Field	Description
<b>Reception/ Breakout (DTMF 0)</b>	<p>The number to which a caller is transferred if they press 0 while listening to the mailbox greeting rather than leaving a message (*0 on Embedded Voicemail in IP Office mode).</p> <p>For voicemail systems set to Intuity emulation mode, the mailbox owner can also access this option when collecting their messages by dialing *0.</p> <p>If the mailbox has been reached through a Voicemail Pro call flow containing a <b>Leave Mail</b> action, the option provided when 0 is pressed are:</p> <ul style="list-style-type: none"> <li>• For IP Office mode, the call follows the <b>Leave Mail</b> action's <b>Failure</b> or <b>Success</b> results connections depending on whether the caller pressed 0 before or after the record tone.</li> <li>• For Intuity mode, pressing 0 always follows the <b>Reception/Breakout (DTMF 0)</b> setting.</li> </ul> <p>When Park &amp; Page is selected for a DTFM breakout, the following drop-down boxes appear:</p> <ul style="list-style-type: none"> <li>• <b>Paging Number</b> – displays a list of hunt groups and users (extensions). Select a hunt group or extension to configure this option.</li> <li>• <b>Retries</b> – the range is 0 to 5. The default setting is 0.</li> <li>• <b>Retry Timeout</b> – provided in the format M:SS (minute:seconds). The range can be set in 15-second increments. The minimum setting is 15 seconds and the maximum setting is 5 minutes. The default setting is 15 seconds</li> </ul>
<b>Breakout (DTMF 2)</b>	The number to which a caller is transferred if they press 2 while listening to the mailbox greeting rather than leaving a message (*2 on Embedded Voicemail in IP Office mode)
<b>Breakout (DTMF 3)</b>	The number to which a caller is transferred if they press 3 while listening to the mailbox greeting rather than leaving a message (*3 on Embedded Voicemail in IP Office mode).

## Forwarding

Navigation: [User Rights | Forwarding](#)

### Additional configuration information

For additional configuration information, see [DND, Follow Me, and Forwarding](#) on page 685.

### Configuration settings

Display the users associated with the user rights and allows these to be changed.

These settings are mergeable.

For a Server Edition network, these settings can be configured at the network level and are then automatically replicated in the configuration of all systems in the network. They can only be seen and edited at the individual system configuration level if record consolidation is switched off.

Field	Description
<b>Block Forwarding</b>	

*Table continues...*

Field	Description
<b>Enable Block Forwarding</b>	<p>Default = Off.</p> <p>When enabled, call forwarding is blocked.</p> <p>The following actions are blocked:</p> <ul style="list-style-type: none"> <li>• Follow me</li> <li>• Forward unconditional</li> <li>• Forward on busy</li> <li>• Forward on no answer</li> <li>• Call Coverage</li> <li>• Hot Desking</li> </ul> <p>The following actions are not blocked:</p> <ul style="list-style-type: none"> <li>• Do not disturb</li> <li>• Voicemail</li> <li>• Twinning</li> </ul>

---

## ARS

ARS (Alternate Route Selection) replaces LCR (Least Cost Routing) used by previous releases of IP Office. It also replaces the need to keep outgoing call routing short codes in the system short codes.

### Related links

[Configuration Mode Field Descriptions](#) on page 197

---

## ARS

Navigation: [ARS](#) | [ARS](#)

### Additional configuration information

This section contains the configuration settings for Alternate Route Selection. For additional configuration information, see [Configuring ARS](#) on page 641

### Configuration settings

Each ARS form contains short codes which are used to match the result of the short code that triggered use of the ARS form, ie. the Telephone Number resulting from the short code is used rather than the original number dialed by the user.

For Server Edition, this type of configuration record can be saved as a template and new records created from a template.

These settings are mergeable. Changes to these settings do not require a reboot of the system.

Field	Description
<b>ARS Route ID</b>	<p>The default value is automatically assigned. Range = 0 to 99999.</p> <p>For most deployments, do not edit this field.</p> <p>For those conditions where it is necessary to edit this field, the value must be unique within ARS and within the line Outbound Group IDs.</p>
<b>Route Name</b>	<p>Default = Blank. Range = Up to 15 characters.</p> <p>The name is used for reference and is displayed in other areas when selecting which ARS to use.</p>
<b>Dial Delay Time</b>	<p>Default = System. Range = 1 to 30 seconds.</p> <p>This settings defines how long ARS should wait for further dialing digits before assuming that dialing is complete and looking for a short code match against the ARS form short codes. When set to <b>System</b>, the system setting <b>System   Telephony   Telephony   Dial Delay Time</b> is used.</p>
<b>Secondary Dial Tone</b>	<p>Defaults = Off.</p> <p>When on, this setting instructs the system to play secondary dial tone to the user. The tone used is set by the field below.</p> <p>The tone used is set as either <b>System Tone</b> (normal dial tone) or <b>Network Tone</b> (secondary dial tone). Both tone types are generated by the system in accordance with the system specific locale setting. Note that in some locales normal dial tone and secondary dial tone are the same.</p> <p>When <b>Secondary Dial Tone</b> is selected, the ARS form will return tone until it receives digits with which it can begin short code matching. Those digits can be the result of user dialing or digits passed by the short code which invoked the ARS form. For example with the following system short codes:</p> <p>In this example, the 9 is stripped from the dialed number and is not part of the telephone number passed to the ARS form. So in this case secondary dial tone is given until the user dials another digit or dialing times out.</p> <ul style="list-style-type: none"> <li>• <b>Code:</b> 9N</li> <li>• <b>Telephone Number:</b> N</li> <li>• <b>Line Group ID:</b> 50 Main</li> </ul> <p>In this example, the dialed 9 is included in the telephone number passed to the ARS form. This will inhibit the use of secondary dial tone even if secondary dial tone is selected on the ARS form.</p> <ul style="list-style-type: none"> <li>• <b>Code:</b> 9N</li> <li>• <b>Telephone Number:</b> 9N</li> <li>• <b>Line Group ID:</b> 50 Main</li> </ul>

*Table continues...*

Field	Description
<b>Check User Call Barring</b>	<p>Default = Off</p> <p>If enabled, the dialing user's <b>Outgoing Call Bar</b> setting and any user short codes set to the function <b>Barred</b> are checked to see whether they are appropriate and should be used to bar the call.</p>
<b>Description</b>	<p>Default = Blank. Maximum 31 characters.</p> <p>Use this field to enter a description of this configuration.</p>
<b>In Service:</b>	<p>Default = On</p> <p>This field is used to indicate whether the ARS form is in or out of service. When out of service, calls are rerouted to the ARS form selected in the <b>Out of Service Route</b> field.</p> <p>Short codes can be used to take an ARS form in and out of service. This is done using the short code features Disable ARS Form and Enable ARS Form and entering the ARS Route ID as the short code <b>Telephone Number</b> value.</p>
<b>Out of Service Route</b>	<p>Default = None.</p> <p>This is the alternate ARS form used to route calls when this ARS form is not in service.</p>
<b>Time Profile</b>	<p>Default = None.</p> <p>Use of a ARS form can be controlled by an associate time profile. Outside the hours defined within the time profile, calls are rerouted to an alternate ARS form specified in the Out of Hours Route drop-down. Note that the Time Profile field cannot be set until an Out of Hours Route is selected.</p>
<b>Out of Hours Route</b>	<p>Default = None.</p> <p>This is the alternate ARS form used to route calls outside the hours defined within the Time Profile selected above.</p>
<b>Short Codes</b>	<p>Short codes within the ARS form are matched against the "Telephone Number" output by the short code that routed the call to ARS. The system then looks for another match using the short codes with the ARS form.</p> <p>Only short codes using the following features are supported within ARS: <b>Dial</b>, <b>Dial Emergency</b>, <b>Dial Speech</b>, <b>Dial 56K</b>, <b>Dial64K</b>, <b>Dial3K1</b>, <b>DialVideo</b>, <b>DialV110</b>, <b>DialV120</b> and <b>Busy</b>.</p> <p>Multiple short codes with the same <b>Code</b> field can be entered so long as they have differing <b>Telephone Number</b> and or <b>Line Group ID</b> settings. In this case when a match occurs the system will use the first match that points to a route which is available.</p>
<b>Alternate Route Priority</b>	<p>Default = 3. Range = 1 (low) to 5 (high).</p> <p>If the routes specified by this form are not available and an <b>Alternate Route</b> has been specified, that route will be used if the users priority is equal to or higher than the value set here. User priority is set through the <b>User   User</b> form and by default is <b>5</b>. If the users priority is lower than this value, the <b>Alternate Route Wait Time</b> is applied. This field is grayed out and not used if an ARS form has not been selected in the <b>Alternate Route</b> field.</p> <p>If the caller's dialing matches a short code set to the <b>Barred</b> function, the call remains at that short code and is not escalated in any way.</p>

Table continues...



Field	Description
<b>Alternate Route Wait Time</b>	<p>Default = 30 seconds. Range = Off, 5 to 60 seconds.</p> <p>If the routes specified by this form are not available and an <b>Alternate Route</b> has been specified, users with insufficient priority to use the alternate route immediately must wait for the period defined by this value. During the wait the user hears camp on tone. If during that period a route becomes available it is used. This field is grayed out and not used if an ARS form has not been selected in the Alternate Route field.</p>
<b>Alternate Route</b>	<p>Default = None.</p> <p>This field is used when the route or routes specified by the short codes are not available. The routes it specifies are checked in addition to those in this ARS form and the first route to become available is used.</p>

### Cause Codes and ARS

ARS routing to digital trunks can be affected by signalling from the trunk.

The following cause codes cause ARS to no longer target the line group (unless it is specified by an alternate ARS route). The response to cause codes received from the line is as follows.

Code	Cause Code
1	Unallocated Number.
2	No route to specific transit network/(5ESS) Calling party off hold.
3	No route to destination./(5ESS) Calling party dropped while on hold.
4	Send special information tone/(NI-2) Vacant Code.
5	Misdialed trunk prefix.
8	Preemption/(NI-2) Prefix 0 dialed in error.
9	Preemption, cct reserved/ (NI-2) Prefix 1 dialed in error.
10	(NI-2) Prefix 1 not dialed.
11	(NI-2) Excessive digits received call proceeding.
22	Number Changed.
28	Invalid Format Number.
29	Facility Rejected.
50	Requested Facility Not Subscribed.
52	Outgoing calls barred.
57	Bearer Capability Not Authorized.
63	Service or Option Unavailable.
65	Bearer Capability Not Implemented.
66	Channel Type Not Implemented.
69	Requested Facility Not Implemented.

*Table continues...*

Code	Cause Code
70	Only Restricted Digital Information Bearer Capability Is Available.
79	Service Or Option Not Implemented.
88	Incompatible.
91	Invalid Transit Network Selection.
95	Invalid Message.
96	Missing Mandatory IE.
97	Message Type Nonexistent Or Not Implemented.
98	Message Not Implemented.
99	Parameter Not Implemented.
100	Invalid IE Contents.
101	Msg Not Compatible.
111	Protocol Error.
127	Interworking Unspecified.

**Stop ARS** The following cause codes stop ARS targeting completely.

Code	Cause Code
17	Busy.
21	Call Rejected.
27	Destination Out of Order.

**No Affect** All other cause codes do not affect ARS operation.

---

## Location

Navigation: [Location](#) | [Location](#)

### Additional configuration information

This section provides the **Location** field descriptions. For additional configuration information, see:

- [Emergency Call](#) on page 609
- [Configuring Call Admission Control](#) on page 615
- [Preventing Toll Bypass](#) on page 658
- [Configuring Location Based Extension Resiliency](#) on page 759

Configuring locations allows you to specify named locations for groups of phones, IP Office systems, or IP Trunks. The IP Office system must also be assigned a location. Multiple systems in an SCN or Server Edition group of systems may reside in the same location. In an SCN environment, locations must be configured at the top level and therefore, all systems must be

configured with the same settings, except when the emergency ARS needs to be set at the system level.

Once locations have been defined, extensions can be allocated to them in the extension configuration. IP phones can be identified by the IP address that they register from. Each location can have only one subnet defined, but phones outside that subnet can be explicitly assigned that location.

The Location page allows you to define a physical location and associate a network address with a physical location. Locations can then be allocated to extensions. Linking a location to an extension, enables the physical location of a phone to be identified when an emergency call is made.

These settings are mergeable. Changes to these settings do not require a reboot of the system.

Field	Description
<b>Location Name</b>	Default = Blank. A meaningful location name, clearly identifying the geographical position of the phone.
<b>Location ID</b>	Default = Based on existing configured locations, the next incremental value is assigned. This field is read only.
<b>Subnet Address</b>	Default = Blank. The IP address associated with this location. The subnet where this IP address resides must be <u>unique</u> across all configured locations. Overlapping IP address ranges between locations will cause extensions to use the first match found which may not be the correct location.
<b>Subnet Mask</b>	Default = Blank. The subnet mask for this IP address.
<b>Emergency ARS</b>	Default = None. The ARS (Alternate Route Selection) that defines how emergency calls from this location are routed. The drop down list contains all available ARS entries using the format <b>ARS Route ID: Route Name</b> . For example <b>50: Main</b> .
<b>Parent Location for CAC</b>	Default = None. The options are: <ul style="list-style-type: none"> <li>• <b>None</b> The default setting.</li> <li>• <b>Cloud</b> The parent location is an internet address external to the IP Office network. When set to <b>Cloud</b>, the <b>Call Admission Control (CAC)</b> settings are disabled. Calls to this location from other configured locations are counted as external, yet no CAC limits are applied to the location itself.</li> </ul>
<b>Call Admission Control</b>	
The CAC settings, when not unlimited, restrict the number of calls into and out of the location, The following Call Admission Control settings can be configured.	
<b>Total Maximum Calls</b>	Default = Unlimited. Range = 1 - 99, Unlimited. Limit of all calls to or from other configured locations and the cloud.

*Table continues...*

Field	Description
<b>External Maximum Calls</b>	Default = Unlimited. Range = 1 - 99, Unlimited. Limit of calls to or from the cloud in this location.
<b>Internal Maximum Calls</b>	Default = Unlimited. Range = 1 - 99, Unlimited. Limit of calls to or from other configured locations in this location.
<b>Time Settings</b>	
The display of location based time is only supported on 1100, 1200, 1600 and 9600 Series phones and D100, E129 and B179 telephones.	
<b>Time Zone</b>	Default = Same as System Select a time zone from the list.
<b>Local Time Offset from UTC</b>	Default is based on the currently selected time zone. Set the time for this location by entering the offset from UTC.
<b>Automatic DST</b>	Default is based on the currently selected time zone. When set to On, the system automatically corrects for daylight saving time (DST) changes as configured in the <b>Clock Forward/Back Settings</b> below.
<b>Clock Forward/Back Settings (Start Date — End Date (DST Offset))</b>	Default is based on the currently selected time zone. Click <b>Edit</b> to configure the time and date for DST clock corrections. In the Daylight Time Settings window, you can configure the following information: <ul style="list-style-type: none"> <li>• <b>DST Offset:</b> the number of hours to shift for DST.</li> <li>• <b>Clock Forward/Back:</b> Select <b>Go Forward</b> to set the date when the clock will move forward. Select <b>Go Backwards</b> to set the date when the clock will move backward.</li> <li>• <b>Local Time To Go Forward:</b> The time of day to move the clock forward or backward.</li> <li>• <b>Date for Clock Forward/Back:</b> Set the year, month and day for moving the clock forwards and backwards.</li> </ul> Once you click <b>OK</b> , the forward and back dates, plus the DST offset, are displayed using the format <b>(Start Date — End Date (DST Offset))</b> .
<b>Fallback System</b>	Default = No override. The drop down list contains all configured IP Office Lines and the associated IP Office system. The group of extensions associated with this location can fallback to the alternate system selected.

**Related links**

[Configuration Mode Field Descriptions](#) on page 197

[Address](#) on page 564

## Address

Navigation: **Location | Address**

Enter address information to define a specific location. The address fields are based on the standards RFC 4119 and RFC 5139.

If **Line | SIP Line | Advanced | Send Location Info** is set to **Emergency Calls** then the location defined here is sent as part of the INVITE message when emergency calls are made.

These settings are mergeable. Changes to these settings do not require a reboot of the system.

Field	Description	Example
<b>Country Code</b>	The country is identified by the two letter ISO 3166 code.	US
<b>A1</b>	National subdivisions (state, region, province, prefecture).	New York
<b>A2</b>	County, parish, gun (JP), district (IN).	King's County
<b>A3</b>	City, township, shi (JP).	New York
<b>A4</b>	City division, borough, city district, ward, chou (JP).	Manhattan
<b>A5</b>	Neighborhood, block.	Morningside Heights
<b>A6</b>	Street.	Broadway
<b>RD</b>	Primary road or street	Broadway
<b>RDSEC</b>	Trailing street suffix.	SW
<b>RDBR</b>	Road branch.	Lane 7
<b>RDSUBBR</b>	Road sub-branch.	Alley 8
<b>PRD</b>	Leading street direction.	N
<b>POD</b>	Trailing street suffix.	NE
<b>STS</b>	Street suffix.	Avenue, Platz, Street
<b>PRM</b>	Road pre-modifier.	Old
<b>POM</b>	Road post-modifier.	Extended
<b>HNO</b>	House number, numeric part only.	123
<b>HNS</b>	House number suffix.	A, 1/2
<b>LMK</b>	Landmark or vanity address.	Low Library
<b>BLD</b>	Building (structure).	Hope Theatre
<b>LOC</b>	Additional location information.	Room 543
<b>PLC</b>	Place type.	Office
<b>FLR</b>	Floor.	5
<b>UNIT</b>	Unit (apartment, suite).	12a
<b>ROOM</b>	Room.	450F
<b>SEAT</b>	Seat (desk, cubicle, workstation).	WS 181
<b>NAM</b>	Name (residence, business, or office occupant).	Joe's Barbershop
<b>ADDCODE</b>	Additional Code	13203000003
<b>PCN</b>	Postal community name.	Leonia

*Table continues...*

## Configuration Mode Field Descriptions

Field	Description	Example
PC	Postal code.	10027-0401
POBOX	Post office box (P.O. box)	U40

### Related links

[Location](#) on page 562

# Chapter 12: Configure General System Settings

---

## Applying Licenses

For a description of IP Office licenses and for information on licensing requirements, see *Avaya IP Office Platform™ Solution Description*.

### Related links

[PLDS licensing](#) on page 567

[Web License Manager \(WebLM\)](#) on page 568

[Server Edition Centralized Licensing](#) on page 569

[Distributing Server Edition Licenses](#) on page 569

[Procedures for Applying Licensing](#) on page 574

---

## PLDS licensing

IP Office uses the Avaya Product Licensing and Delivery System (PLDS) to manage licenses. PLDS is an online, web-based tool for managing license entitlements and electronic delivery of software and related license files. PLDS provides customers, Avaya Partners, distributors, and Avaya Associates with easy-to-use tools for managing license entitlements and electronic delivery of software and related license files. Using PLDS, you can perform operations such as license activations, license upgrades, license moves, and software downloads. You can access PLDS from <http://plds.avaya.com/>.

### PLDS license files

Licenses are delivered from PLDS with license files. A PLDS license file is generated for installing on a specific machine. There are two deployment options:

- PLDS Nodal license files are generated for and installed on particular IP Office nodes.
- PLDS WebLM license files are generated for and installed on a WebLM server that can license multiple IP Office nodes.

WebLM centralized licensing is supported in IP Office Server Edition and in IP Office Branch deployments, but not in non-Branch deployments of IP Office Standard mode.

## PLDS host ID

PLDS Nodal license files are machine specific and you must specify the host ID in the **PLDS host ID** field on **License | License**.

**IP500 V2 systems:** You can find the PLDS host ID in the **Licensing** tab of IP Office Manager and Web Manager. The PLDS host ID is made of the two digits “11”, followed by the 10 digit feature key serial number printed on the IP Office SD card. If the SD card is changed, the PLDS host ID will also change.

**IP Office Linux servers:** The PLDS host ID can be found on the server labeling, the server packaging label, and the system ignition Login screen. The PLDS host ID is derived from the system ID. If the system ID changes, the PLDS host ID will also change.

**WebLM:** The WebLM host ID is the Mac address of the WebLM server. In a virtual environment, the WebLM host ID is a virtual Mac address that starts with the letter “V”. The WebLM host ID must be used when generating a PLDS license file for the WebLM server in order to implement a centralized licensing scheme for multiple IP Office systems. The WebLM host ID can be found on the server labeling, the server packaging label, the system ignition Login screen, and through the WebLM management interface.

### Related links

[Applying Licenses](#) on page 567

---

## Web License Manager (WebLM)

The Web License Manager (WebLM) is a web-based application for managing licenses. If you use the WebLM server running on the IP Office server, then you can use IP Office Web Manager to log in to the WebLM server by selecting **Applications > Web License Manager**. WebLM credentials are managed separately from IP Office system passwords and are not part of single sign on (SSO).

### \* Note:

- WebLM license management is supported for Server Edition deployments and for Enterprise Branch deployments using the System Manager WebLM server. It is not supported for Standard Mode systems.
- When upgrading from a previous release, all systems must be running the same software level. IP Office Server Edition does not support mixed versioning.

For more information on WebLM, see *Administering standalone Avaya WebLM*.

To establish communication between IP Office and the WebLM server, you must configure the remote server profile on **License | Remote Server**.

### \* Note:

When upgrading from release 9.1, the WebLM server is not started automatically. Perform the following steps to start the WebLM server.

1. Log in to Web Manager.
2. Select **Server Menu > Platform View > System**.
3. Under **Services**, select the WebLM server and click **Start**.



**Related links**

[Applying Licenses](#) on page 567

---

## Server Edition Centralized Licensing

Before release 10, Server Edition deployments used nodal licensing. This type of licensing can still be used in release 10 and higher. However, it is expected that most deployments will prefer to centralize license management using the Avaya Web License Management (WebLM) server. The WebLM server is automatically installed on the Server Edition Primary server. For newly installed systems, centralized licensing is the default configuration.

All systems in the Server Edition solution must use the same **License Source**.

### Nodal licensing

With nodal licensing, license files must be installed on each node in the system. For some licensed features, the required license can be installed on the Server Edition Primary server and used by all nodes in the system. However, for other licensed features, the required license must be installed on the node where the feature is used.

### Centralized licensing

As of release 10, you can use the WebLM server running on the Server Edition Primary server to fully centralize license management. With centralized license management, all licenses are contained in a single PLDS file uploaded to WebLM. All nodes in the solution obtain their licenses from WebLM.

The IP Office Secondary server and Expansion systems can be configured to request licenses directly from the WebLM server, or to use a proxy option. When configured to use the proxy option, the license requests are sent through the IP Office Primary server, which proxies the requests to the WebLM server. The Primary server does not allocate licenses, but only acts as a proxy.

Systems using nodal licensing can be converted to use centralized licensing. Since PLDS license files are generated using the host ID of the server where they reside, you must regenerate the license file using the host ID of the WebLM server that will host the license file.

**Related links**

[Applying Licenses](#) on page 567

---

## Distributing Server Edition Licenses

 **Note:**

For a description of IP Office licenses and for information on licensing requirements, see *Avaya IP Office Platform™ Solution Description*.

The **License | Remote Server** page displays the **Reserved Licenses** allocated to a Server Edition server.

**\* Note:**

The **SIP Trunk Sessions** field has replaced the **System | Telephony | Telephony | Max SIP sessions** setting.

License
Remote Server

Remote Server Configuration

License Source	WebLM
Domain Name (URL)	https://192.168.42.1
Path	WebLM/LicenseServer
Port Number	52233
WebLM client ID	

Reserved Licenses

SIP Trunk Sessions	0	Server Edition	1
SM Trunk Sessions	0	Avaya IP Endpoints	0
Voicemail Pro Ports	2	3rd Party IP Endpoints	0
VMPro Recordings Administrators	0	Receptionist	0
VMPro TTS Professional	0	Basic User	0
CTI Link Pro	0	Office Worker	0
UMS Web Services	0	Power User	0
Mac Softphones	0	Avaya Softphone	0
Avaya Contact Center Select	0	Web Collaboration	0
Third Party Recorder	0		

### PLDS File Location

How licenses are allocated depends on the location of the PLDS file. For standalone systems, SCN deployments, and Server Edition nodal licensing, each node in the system must have a PLDS file installed.

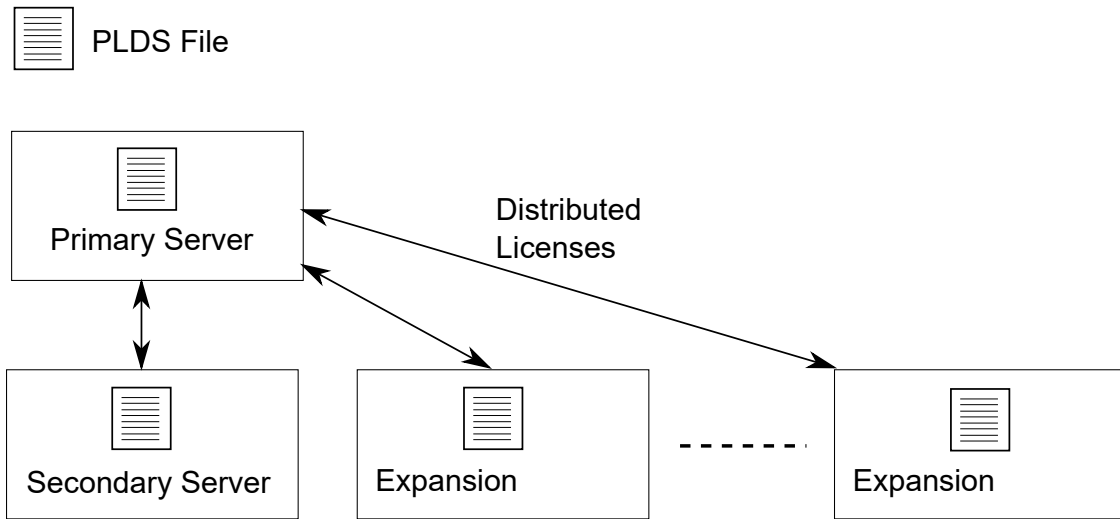

**Figure 1: PLDS file location for Server Edition Nodal Licensing**

For Server Edition centralized licensing, the PLDS file is located on the WebLM server. The WebLM server can be located on the Primary Server or on a remote server.

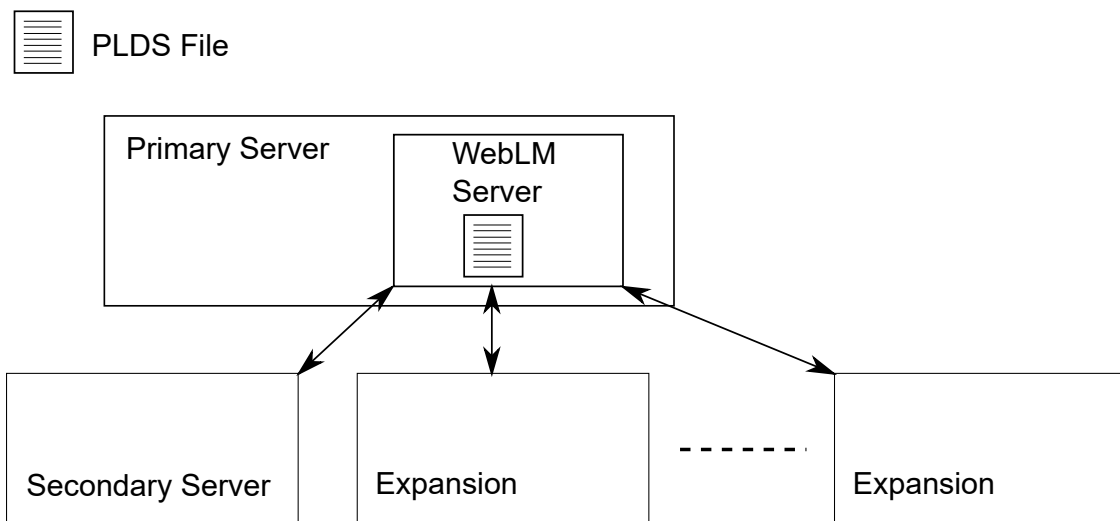

**Figure 2: PLDS file location for Server Edition Centralized Licensing**

**Related links**

[Applying Licenses](#) on page 567

[Nodal license distribution](#) on page 572

[Centralized license distribution](#) on page 573

## Nodal license distribution

When the **License Source** is **Local**, the **Reserved Licenses** read-only fields indicate licenses that are required for the currently configured features.

Nodal licensing for a Server Edition solution is based on a combination of licensing done through the Server Edition Primary server plus some server-specific licenses. All the user specific and system specific licenses can be managed from the Server Edition Primary server that also acts as a licensing server. Licenses are entered into the configuration of the Server Edition Primary server and are based on the system ID of that server.

Where a license is used to enable features, such as SIP Trunk channels, on other systems, the Server Edition Primary server only allocates those licenses to other systems after it has met its own license needs.

When another system loses connection to the Server Edition Primary server, any license requirements based on those licenses entered in the Server Edition Primary server's configuration are supported for a grace period of 30 days.

Other server specific licenses are entered into the configuration of the server requiring the feature and are based on the System ID of that system.

License	Primary server	Server-specific
Server Edition	Yes	No
Avaya IP endpoints	Yes	No
Third-party IP endpoints	Yes	No
SIP trunk channels	Yes	No
IP500 universal PRI channels	No	Yes
Additional voicemail ports [3]	Yes	No
Web Collaboration	No	Yes
UMS Web Services [1]	No	Yes
Office Worker	Yes	No
Power User	Yes	No
Office Worker to Power User upgrade	Yes	No
Receptionist	No	Yes
CTI Link Pro	No	Yes
Messaging TTS Pro [3]	Yes	No
Voicemail Pro Recording Administrator [2] [3]	Yes	No
WAV User	No	Yes
IPSec tunneling	No	Yes

1. UMS Web Service licenses are for Hunt Groups only.

2. The Voicemail Pro Recording Administrator license refers to Contact Store. Only one license is required for a Server Edition network.
3. For deployments with dual Voicemail Pro servers, Messaging TTS Pro, Voicemail Pro Recording Administrator, and Additional voicemail ports licenses must be on the Secondary Server.

### Related links

[Distributing Server Edition Licenses](#) on page 569

## Centralized license distribution

When the license source is WebLM, the **Reserved Licenses** read-only fields indicate licenses that are required for the currently configured features. Editable fields can be used to:

- Request additional licenses from the WebLM server.
- Remove licenses from the IP Office node to apply them elsewhere.

### Important:

When reallocating licenses, always reduce the number on the IP Office node where they are currently applied before applying them on another node. If you exceed the number of licenses available, you will receive an error message.

### Distribution after conversion from Nodal to Centralized licensing

- If the IP Office node needs any of the following licenses, then you must manually configure the respective **Reserved Licenses** editable fields. This will allow the IP Office node to request the licenses from the WebLM server.
  - **VMP Pro Recordings Administrators**
  - **VMP Pro TTS Professional**
  - **CTI Link Pro**

**Extension Reserved license setting:** When the license source is **Local**, the setting **Extension > VoIP > Reserve License** is set to **None**. Switching the license source to WebLM changes the setting to **Reserve Avaya IP endpoint license**. If required, you must manually change this setting to **Reserve 3rd party endpoint license** or **Both**.

### License allocation in WebLM

You can use WebLM to view the licenses used by each node in IP Office Server Edition. In the WebLM navigation pane on the left, click **Licensed Products**. The Acquired licenses table displays information about the licenses acquired for each client ID. In IP Office, the WebLM client ID for each node is displayed on the license Remote Server page.

### Related links

[Distributing Server Edition Licenses](#) on page 569

## Procedures for Applying Licensing

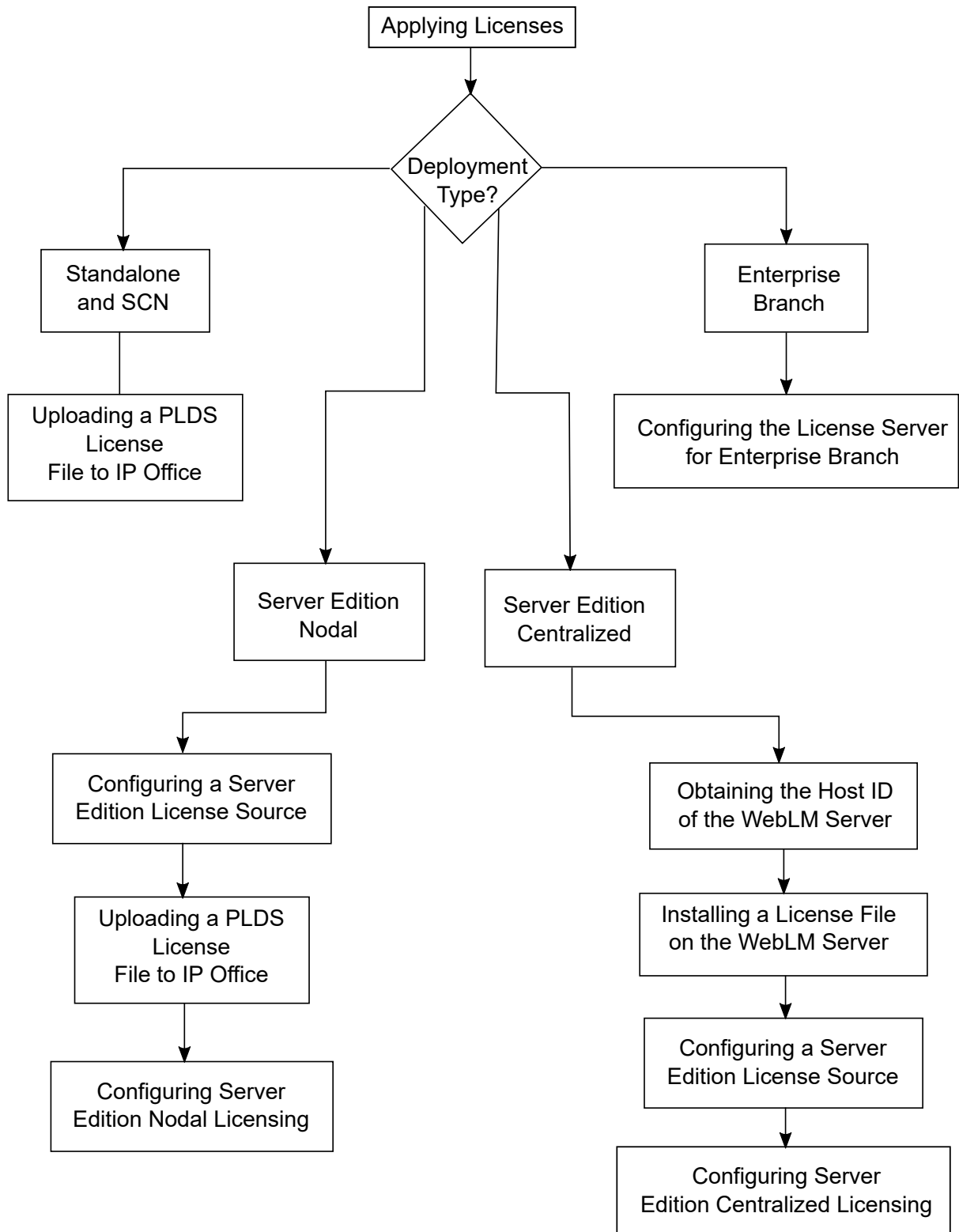

## Related links

[Applying Licenses](#) on page 567

[Obtaining the Host ID of the WebLM Server](#) on page 575

[Installing a License File on the WebLM Server](#) on page 575

[Configuring the Server Edition License Source](#) on page 576

[Uploading a PLDS License File to IP Office](#) on page 576

[Configuring Server Edition Nodal Licensing](#) on page 577

[Configuring Server Edition Centralized Licensing](#) on page 577

[Configuring the License Server in an Enterprise Branch Deployment](#) on page 579

## Obtaining the Host ID of the WebLM Server

The WebLM Host ID is required to generate a PLDS license file for centralized licensing. The license file is uploaded to the WebLM server.

### Procedure

1. In Web Manager, select **Applications > Web License Manager**.
2. Log in to WebLM.
3. In the navigation pane on the left, click **Server Properties**.

The Server Properties page displays the Host ID. The host ID is the MAC address of the Server Edition Primary server.

Record the host ID.

## Related links

[Procedures for Applying Licensing](#) on page 574

## Installing a License File on the WebLM Server

Use Web Manager to log in to the WebLM license server and install a license file.

### Before you begin

Obtain the license file from the Avaya Product Licensing and Delivery System (PLDS) Web site at <https://plds.avaya.com>.

You must know the user ID and password for the WebLM server. WebLM credentials are managed separately from IP Office system passwords and are not part of single sign on.

### Procedure

1. Log in to Web Manager.
2. Select **Applications > Web License Manager**.
3. Log in to the WebLM server.
4. In the left navigation pane, click **Install license**.
5. On the Install license page, click **Browse** to select the license file.

6. Click **Install** to install the license file.

WebLM displays a message upon successful installation of the license file.

If the installation is not successful, for troubleshooting information see *Administering Avaya WebLM*, available on the Avaya support site at <https://downloads.avaya.com/css/P8/documents/100157154>.

#### Related links

[Procedures for Applying Licensing](#) on page 574

## Configuring the Server Edition License Source

For Server Edition deployments, the license source can be centralized or nodal.

- With centralized licensing, the PLDS license file resides on the WebLM server. The WebLM server is the license source and all nodes in the solution receive licenses from the WebLM server. The WebLM server can run on a remote machine or on the Primary Server.
- With nodal licensing, a PLDS license file is uploaded to each node.

All systems in the Server Edition solution must use the same license source. The license source is defined by the configuration setting **License | License | License Source**. Use this procedure to set all nodes to use the same license source.

#### Procedure

1. Log in to Manager.
2. On the Solution view page, on the right hand side, select **Set All Nodes License Source**.
3. In the Select License Source window, select either
  - **Local/Primary Server** for nodal licensing.
  - **WebLM** for centralized licensing.

All nodes in the solution are set to the same license source.

#### Related links

[Procedures for Applying Licensing](#) on page 574

## Uploading a PLDS License File to IP Office

Use this procedure to upload a PLDS license file for nodal license management. Nodal license management is used for standalone IP500 V2 systems and is an option for Server Edition systems.

#### Before you begin

The PLDS license file must be on the local machine where IP Office Manager is running

#### Procedure

1. In IP Office Manager, select the Primary Server and then select **License | License**.
2. Click **Add**.



3. In the Upload Files window, navigate to the license file.
4. Select the file and click **Open**.

#### Related links

[Procedures for Applying Licensing](#) on page 574

## Configuring Server Edition Nodal Licensing

With nodal licensing, licenses are managed using license files installed on each node in the system. For information on license distribution, see [Distributing Nodal Licenses](#) on page 572.

### Procedure

1. In IP Office Manager, select the Primary Server and then select **License | Remote Server**.
2. In the **Licence Source** field, select **Primary**.

#### \* Note:

All systems in the Server Edition solution must use the same **License Source**. In Manager, on the Solution page, you can select **Set All Nodes License Source** to configure the setting for all nodes in the solution.

3. Enter the Server Edition Primary server IP address in the **License Server IP Address** field.
4. Under **Reserved Licenses**, the right hand column indicates which licenses have been reserved for this system. Use the left hand column to request additional licenses for this system.
5. Click **OK**.  
Licenses are displayed in the table.
6. Repeat steps 1 to 5 for the Server Edition Secondary server and all Server Edition Expansion Systems.

#### Related links

[Procedures for Applying Licensing](#) on page 574

## Configuring Server Edition Centralized Licensing

With centralized licensing, licenses are managed from a central WebLM server.

### Before you begin

You must have a PLDS license file activated with the host ID of the WebLM server

### Procedure

1. In IP Office Manager, select the Primary Server and then select **License | Remote Server**.
2. Ensure **Licence Source** is set to **WebLM**.

**\* Note:**

All systems in the Server Edition solution must use the same **License Source**. In Manager, on the Solution page, you can select **Set All Nodes License Source** to configure the setting for all nodes in the solution.

3. The WebLM server can be located on the Server Edition Primary server or on a separate server. Enter the domain name or IP address of the WebLM server in the **Domain Name (URL)** field.

Note that the domain name URL must use `https://`.

4. If required, change the path to the WebLM server in the **Path** field.
5. Under **Reserved Licenses**, the right hand column indicates which licenses will be automatically requested from the WebLM server. Use the left hand column to request additional license types for this system.
6. Navigate to the **Remote Server** page for the Server Edition Secondary server.
7. Ensure the **Licence Source** is set to **WebLM**.
8. You can choose to enable the **Enable proxy via Primary IP Office line** check box.

Choice Option	Choice Description
<b>Enabled</b>	The WebLM request is sent to the WebLM server via the IP Office line configured to the Server Edition Primary server. The line must be up and in service
<b>Disabled</b>	The WebLM request is sent directly to the WebLM server.

9. If **Enable proxy via Primary IP Office line** is enabled, enter the Server Edition Primary server IP address in the **Primary IP Address** field.
10. If **Enable proxy via Primary IP Office line** is disabled:
  - a. Enter the domain name or IP address of the WebLM server in the **Domain Name (URL)** field.
  - b. If required, change the path to the WebLM server in the **Path** field.
  - c. If required change the default **Port Number**.

For information on port usage see the IP Office Port Matrix document on the Avaya support site at <https://support.avaya.com/helpcenter/getGenericDetails?detailId=C201082074362003>.

11. Click **OK**.  
Licenses are displayed in the **License | License** table.
12. Repeat steps 8 to 12 for all Server Edition Expansion Systems.

**\* Note:**

In Manager, on the Solution page, you can select **Set All Nodes License Source**.

**Related links**

[Procedures for Applying Licensing](#) on page 574

**Configuring the License Server in an Enterprise Branch Deployment**

Use this procedure to configure WebLM centralized licensing where a shared PLDS license file is installed on the WebLM server. This is the recommended method for installing license files on IP Office systems that are centrally managed by System Manager.

For a complete description of deploying Enterprise Branch, see *Deploying Avaya IP Office™ Platform as an Enterprise Branch with Avaya Aura® Session Manager*.

**Procedure**

1. Log in to IP Office Manager and select **License | Remote Server**.
2. Select the **Enable Remote Server** check box.  
The **Reserved Licenses** information is displayed.
3. In the **Domain Name (URL)**, field, enter the domain name or IP address of the WebLM server or the domain name of System Manager if the system is under System Manager control.
4. **(Optional)** If a secondary System Manager is configured, enter the domain name in the **Secondary Domain Name (URL)** field.
5. If required, change the path to the WebLM server in the **Path** field.
6. If required change the default **Port Number**.

For information on port usage see the IP Office Port Matrix document on the Avaya support site at <https://support.avaya.com/helpcenter/getGenericDetails?detailId=C201082074362003>.

7. Under **Reserved Licenses**, the right hand column indicates which licenses will be automatically requested from the WebLM server. Use the left hand column to request additional licenses for this system.

**Related links**

[Procedures for Applying Licensing](#) on page 574

---

**Converting from Nodal to Centralized Licensing**

If you are upgrading from an earlier release, perform the procedure [Migrating Licenses to PLDS](#) on page 580.

**\* Note:**

When upgrading from a previous release, all system must be running the same software level. The IP Office Server Edition Solution does not support mixed versioning.

## Procedure

1. You must generate a license file using the WebLM host ID. Perform the following steps to find the WebLM host ID.
  - a. In Web Manager, select **Applications > Web License Manager**.
  - b. Log in to WebLM.
  - c. In the navigation pane on the left, click **Server Properties**.

The Server Properties page displays the Host ID. The host ID is the MAC address of the Server Edition Primary server.

Record the host ID.

2. Generate a PLDS license file using the WebLM host ID.
3. Upload the license file.
  - a. In Web Manager, select **ApplicationsWeb License Manager**.
  - b. In the navigation pane on the left, click **Install license**.
  - c. Click **Browse** to select the license file.
  - d. Click **Install** to install the license file.
4. All nodes in the solution must have the same license source. To configure centralized licensing, all nodes must have the **License Source** set to **WebLM**. You can use Manager to set all nodes to the same license source. On the Manager Solution page, on the right hand side, select **Set All Nodes License Source** and then select **WebLM**.
5. If you are performing this procedure after an upgrade, you must ensure that the **Domain Name (URL)** field is populated on the Server Edition Primary server.
  - a. In Web Manager select for the Server Edition Primary server.
  - b. Ensure that the **Domain Name (URL)** field contains the domain name or IP address of the Server Edition Primary server.
6. Reallocate the licenses as required. See [Distributing Centralized Licenses](#) on page 573.

Note that the previously install local licenses are listed as obsolete. You can use this list to determine which licenses to request from the WebLM server. Once licenses have been reallocated, you can delete the obsolete licenses.

---

## Migrating Licenses to PLDS

IP Office release 10 and higher supports only the Product Licensing and Delivery System (PLDS) to manage license files. If you are upgrading from a previous release, you must migrate all of your pre-R10 licenses (ADI, PLDS, mix of ADI/PLDS, virtual) to R10 PLDS licenses. The license migration tool extracts all the licensing information from an IP Office system and saves it to a file. This file can then be used prepare a software upgrade quote in the Avaya One Source Configurator in order to obtain the required new PLDS R10 licenses.

For Server Edition deployments, the License Migration tool collects licensing information from every node in the solution.

 **Note:**

- You must use the release 10 or higher Manager client to generate the license inventory file.  
You can install Manager before upgrading to release 10. See the procedure Installing Manager.
- License migration is supported on all IP Office modes, release 6.0 and higher.
- The license migration tool can only be used with an online configuration. The **Tools > License Migration** option is disabled for offline configurations.
- The license migration tool is not available on UCM and Application servers. When you run the license migration tool on a Server Edition server, the tool collects licensing information from every node in the solution.
- The generated file can be read but must not be edited. License migration will fail if the file has been edited.

### Before you begin

Ensure all licenses are loaded on the system before performing the license migration. For Server Edition deployments, ensure all nodes are online in order to capture the current view of systems in the solution.

The IP Office configuration must be opened online. The License Migration tool is not available in offline mode.

### Procedure

1. Log in to Manager and select **Tools > License Migration**.

The Save As window opens.

2. Select a location to save the file and enter a file name.
3. Click **Save**.

The file is saved with a `.zip` extension.

### Next steps

Use the file to prepare a software upgrade quote in the Avaya One Source Configurator in order to obtain the required new PLDS R10 licenses. Once you have the PLDS license files, apply them to the system.

---

## Certificate Management

### Related links

[Certificate Overview](#) on page 582

[Certificate Support](#) on page 586

---

## Certificate Overview

Public key cryptography is one of the ways to maintain a trustworthy networking environment. A public key certificate (also known as a digital certificate or identity certificate) is an electronic document used to prove ownership of a public key. The certificate includes information about the key, information about its owner's identity, and the digital signature of an entity that has verified the certificate's contents are correct. If the signature is valid, and the person examining the certificate trusts the signer, then they know they can use that key to communicate with its owner.

The system used to provide public-key encryption and digital signature services is called a public key infrastructure (PKI). All users of a PKI should have a registered identity which is stored in a digital format and called an Identity Certificate. Certificate Authorities are the people, processes and tools that create these digital identities and bind user names to public keys.

There are two types of certificate authorities (CAs), root CAs and intermediate CAs. In order for a certificate to be trusted and for a secure connection to be established, that certificate must have been issued by a CA that is included in the trusted certificate store of the device that is connecting. If the certificate was not issued by a trusted CA, the connecting device then checks to see if the certificate of the issuing CA was issued by a trusted CA, and so on until either a trusted CA is found. The trusted certificate store of each device in the PKI must contain the required certificate chains for validation.

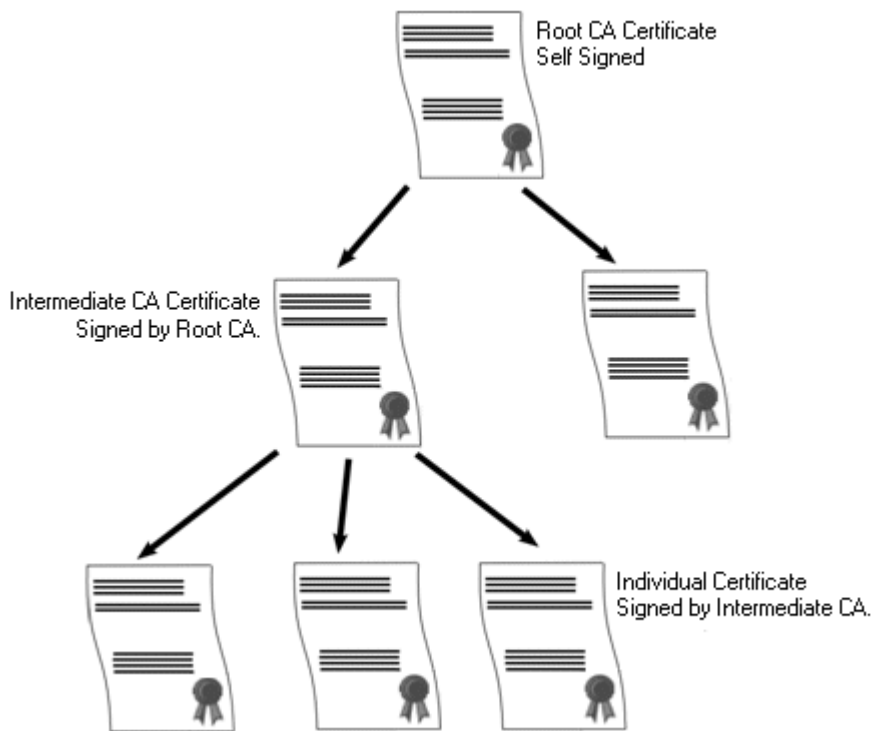

## IP Office Root Certificate Authority

IP Office generates a self-signed certificate. For IP500 V2 systems, a certificate is generated automatically on the first start up. On Linux systems, a certificate is generated during the ignition process.

The following entities can act as the certificate authority.

- The Server Edition Primary Server, an Application Server, or a Unified Communication Module (UCM) can act as the root certificate authority for all nodes in the system.
- In Enterprise Branch deployments, the System Manager can act as the root certificate authority.
- Identity certificates can also be purchased and issued by a third party certificate authority.

Regardless of the method used to provide the IP Office identity, the certificate authority which signs the IP Office identity certificate must be trusted by all the clients and endpoints that need to establish a secure connection with IP Office. They must be a part of the PKI. Therefore, the root CA certificate must be downloaded to client devices and placed in the trusted certificate store. If there are intermediate CAs in the certificate chain, either the intermediate CAs must be added to the client device Trusted Certificate Store or the certificate chain must be advertised by IP Office in the initial TLS exchange.

## Certificates and TLS

Telephony signaling like SIP messaging is secured using Transport Layer Security (TLS). TLS provides communication security using certificates to authenticate the other end of the IP Link.

The message exchange in TLS is aimed at verifying the identity of the communicating parties and establishing the keys that will be used to encrypt the signaling data between the two parties. Typically, the server sends its identity certificate, either self-signed or signed by the CA, to the client. The client must have the CA certificate in its trusted certificate store.

IP Office acts as the TLS server in its interactions with SIP telephony clients. This means that the TLS application on the IP Office must be configured to listen for client connections by enabling TLS in the SIP Registrar on the LAN1 and LAN2 interfaces.

### Note:

- Authentication of the client's certificate by the server is not a requirement. IP Office does not support client certificate validation for all SIP endpoint types.
- The E.129 phone does not validate the IP Office identity certificate.

### Related links

[Certificate Management](#) on page 581

[Windows Certificate Store](#) on page 583

## Windows Certificate Store

The certificate store used by Manager to save and retrieve X509 certificates is the default one provided by the Windows operating system. The Windows certificate store is relevant to any application running on Windows that uses certificates for security, either TLS or HTTPS. For example, the Avaya Communicator Client.

**Warning:**

Avaya accepts no responsibility for changes made by users to the Windows operating system. Users are responsible for ensuring that they have read all relevant documentation and are sufficiently trained for the task being performed.

### Windows Certificate Store Organization

By default, certificates are stored in the following structure:

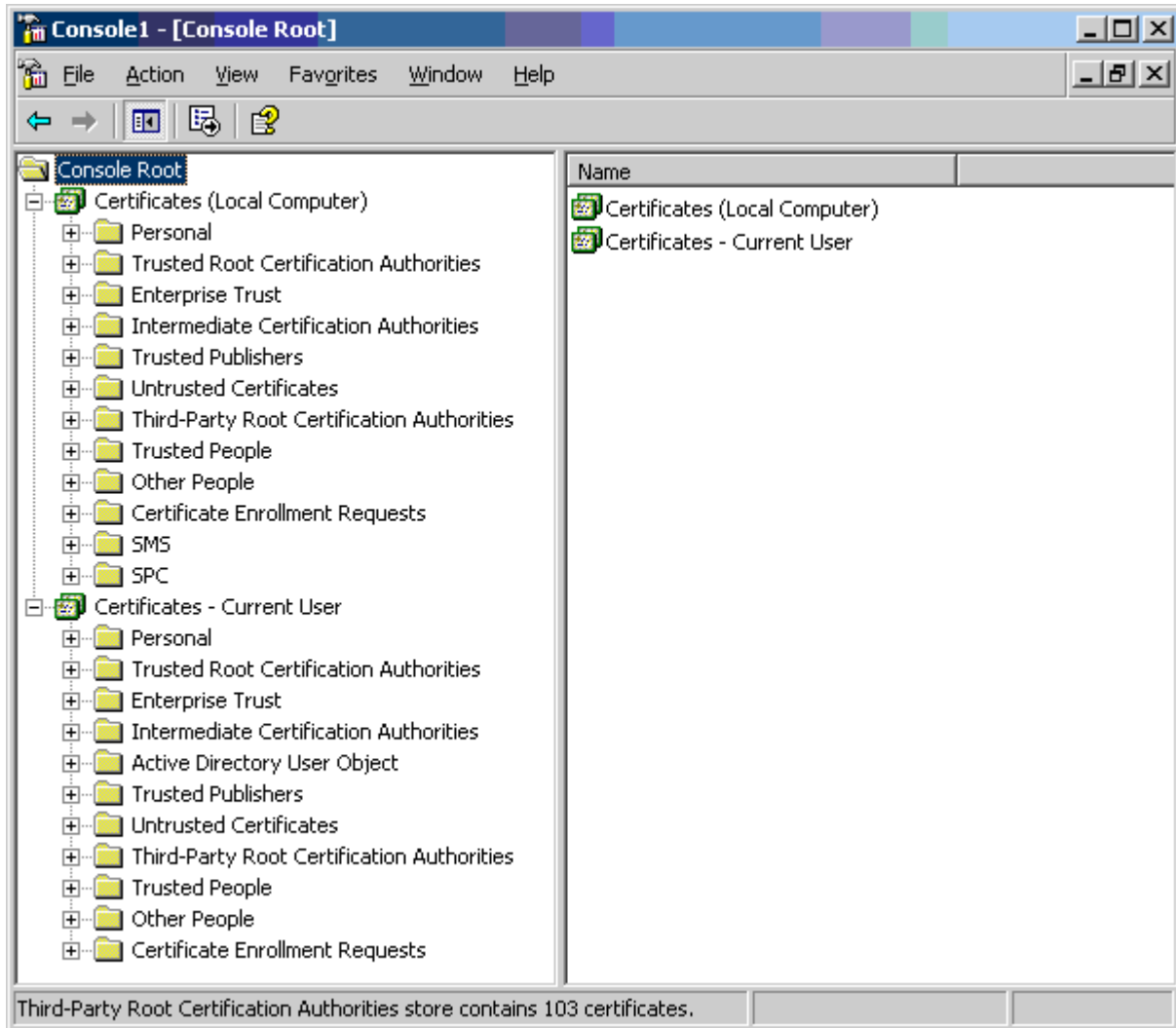

Each of the sub folders has differing usage. The Certificates - Current User area changes with the currently logged-in windows user. The Certificate (Local Computer) area does not change with the currently logged-in windows user.

Manager only accesses some of the certificate sub folder:



Certificates (Local Computer) Folder	Manager Use
<b>Personal   Certificates</b>	<p>Folder searched by Manager 1st for matching certificate to send to the system when requested. Certificate matched by the subject name contained in <b>File   Preferences   Security   Certificate</b> offered to the system.</p> <p>Folder accessed whenever '<b>Local Machine certificate store</b>' used for Security Settings.</p> <p>Folder searched by Manager for matching certificate when certificate received from the system, and <b>File   Preferences   Security   Manager Certificate Checks</b> = Medium or High.</p>
<b>Trusted Root Certification Authorities   Certificates</b>	Folder searched by Manager for matching parent certificates when non-self signed certificate received from the system, and <b>File   Preferences   Security   Manager Certificate Checks</b> = Medium or High.

Certificates – Current User Folder	Manager Use
<b>Personal   Certificates</b>	<p>Folder searched by Manager 2nd for matching certificate (subject name) to send to the system when requested. Certificate matched by the subject name contained in <b>File   Preferences   Security   Certificate</b> offered to the system.</p> <p>Folder accessed whenever '<b>Current User certificate store</b>' used for Security Settings.</p> <p>Folder searched by Manager for matching certificate when certificate received from IP Office, and <b>File   Preferences   Security   Manager Certificate Checks</b> = Medium or High.</p>
<b>Trusted Root Certification Authorities   Certificates</b>	Folder searched by Manager for matching parent certificates when non-self signed certificate received from the system, and <b>File   Preferences   Security   Manager Certificate Checks</b> = Medium or High.
<b>Other People   Certificates</b>	Folder searched by Manager for matching parent certificates when non-self signed certificate received from the system, and <b>File   Preferences   Security   Manager Certificate Checks</b> = Medium or High.

## Windows Certificate Store Import

In order to use certificates – either for security settings or Manager operation – they must be present in the windows certificate store. Certificates may be placed in the store by the Certificate Import Wizard. The Certificate Import Wizard can be used whenever a certificate is viewed. In

order for Manager to subsequently access this certificate the **Place all certificate in the following store** option must be selected:

- If the certificate is to subsequently identify the system, the Other People folder should be used.
- If the certificate is to subsequently identify the Manager, the Personal folder should be used, and the associated private key saved as well.

### Certificate Store Export

Any certificate required outside of the Manager PC must be first saved in the Certificate store, then exported.

If the certificate is to be used for identity checking (i.e. to check the far entity of a link) the certificate alone is sufficient, and should be saved in PEM or DER format.

If the certificate is to be used for identification (i.e. to identify the near end of a link) the certificate and private key is required, and should be saved in PKCS#12 format, along with a password to access the resultant .pfx file.

#### Related links

[Certificate Overview](#) on page 582

---

## Certificate Support

#### Related links

[Certificate Management](#) on page 581

[Certificate File Naming and Format](#) on page 586

[Identity Certificate](#) on page 587

[Trusted Certificate Store](#) on page 589

[Signing Certificate](#) on page 591

[Certificate File Import](#) on page 592

### Certificate File Naming and Format

**DER:** Distinguished Encoding Rules (DER) format, which is a binary format used to represent a certificate. Typically used to describe just one certificate, and cannot include a private key.

There are four main encodings/internal formats for certificate files. Note that these are encodings, not file naming conventions.

**PEM:** Privacy Enhanced Mail (PEM) is a Base 64 (i.e. ASCII text) encoding of DER, one certificate is enclosed between '-----BEGIN CERTIFICATE-----' and '-----END CERTIFICATE-----' statements. Can contain a private key enclosed between '-----BEGIN PRIVATE KEY -----' and '-----END BEGIN PRIVATE KEY -----' statements. More than one certificate can be included. PEM can be identified by viewing the file in a text editor. This is an unsecure format and not recommended for private key use unless it is protected with a password.

**PKCS#12:** Public Key Cryptography Standard (PKCS) #12. A secure, binary format, encrypted with a password. Typically used to describe one certificate, and its associated private key, but can also include other certificates such as the signing certificate(s). This is the recommended format for private key use.

**PKCS#7:** A Base 64 (i.e. ASCII text) encoding defined by RFC 2315, one or more certificates are enclosed between '—BEGIN PKCS—' & '—END PKCS7—' statements. It can contain only Certificates & Chain certificates but not the private key. Can be identified by viewing the file in a text editor.

There are many common filename extensions in use:

- .CRT — Can be DER or PEM. Typical extension used by Unix/Android systems' public certificates files in DER format.
- .CER — Can be DER or PEM. Typical extension used by Microsoft/Java systems' public certificates files in PEM format.
- .PEM — Should only be PEM encoded.
- .DER — Should only be DER encoded.
- .p12 — Should only be in PKCS#12 format. Typical extension used by Unix/Android systems' identity certificates/private key pair files. Same format as .pfx hence can be simply renamed.
- .pfx — Should only be in PKCS#12 format. Typical extension used by Microsoft systems' identity certificates/private key pair files. Same format as .p12 hence can be simply renamed.
- .pb7 — Should only be in RFC 2315 format. Typical extension used by Microsoft and Java systems for certificate chains.

#### Related links

[Certificate Support](#) on page 586

### Identity Certificate

Feature	Support	Notes
Import: Public key size	Yes	RSA 1024, 2048 and 4096 bit public keys must be supported. Any other sizes are optional.  Import of RSA public key less than 1024 or greater than 4096 bits to be rejected with an informative error.  Import of certificates with 1024 will be imported after a warning 'The certificate public key may not be of sufficient strength. Do you wish to continue?'
Import: Certificate signature algorithm	Yes	SHA-1, SHA-256 SHA-384, and SHA-512 hashing algorithms must be supported. Any other SHA2 algorithms are optional.  Import of certificates with SHA-1 will be imported after a warning 'The certificate signature algorithm may not be of sufficient strength. Do you wish to continue?'  Import of certificates with other algorithms (for example MD5, ECC) to be rejected with an informative error.
Import: Must have private key	Yes	Must be supplied.  Reject and informative error that private key has not been supplied

*Table continues...*

Feature	Support	Notes
Import: Certificate checks	Yes	<p>Minimum checks for:</p> <ul style="list-style-type: none"> <li>• Version (v3)</li> <li>• Start + end (present)</li> <li>• Subject Name (present)</li> <li>• Issuer Name (present)</li> <li>• Data integrity (e.g. hash)</li> </ul> <p>Reject + informative error if a check fails</p>
Import: Certificate up to 4KB	Yes	Certificates can be varying sizes
Import: Formats	Yes	<ul style="list-style-type: none"> <li>• PKCS#12 format. '.p12' and '.pfx' file extension. With or without password. This shall be the preferred/default option</li> <li>• PEM format. '.cer' '.pem' and '.crt' file extension.</li> <li>• Pasted from clipboard in PEM format (optional)</li> </ul> <p>NOTE that ONLY PKCS#12 file format is acceptable according to 147434–030–P1, however we cannot control what format customers receive their certificates in, hence all should be supported</p> <p>See section below for certificate file import support</p>
Import: Up to 4 other certificates in same file	Yes	<p>Only supported where management of TCS also available.</p> <ul style="list-style-type: none"> <li>• Any intermediate and root CA certificate included in the PKCS#12 file to be imported into the Trusted Certificate store</li> <li>• The feature is intended for import of intermediate certificates, but can include unrelated certificates.</li> <li>• An informative message to the admin if any have been imported</li> </ul>
Import: Certificate chain support	Yes	Where identity certificate is signed by one or more intermediate CAs, search TCS for matching certificates and include in identity certificate chain.

*Table continues...*

Feature	Support	Notes
View: Certificate Contents	Yes	Minimum viewable attributes (From CEC016: 147434–030–P1): <ul style="list-style-type: none"> <li>• Serial Number</li> <li>• Subject Name</li> <li>• Issuer Name</li> <li>• Validity Period (that includes notBefore and notAfter dates)</li> <li>• Thumbprint (Hash of the certificate)</li> <li>• Subject Alternative Names</li> <li>• Key Usage Extensions</li> <li>• Extended Key Usage</li> </ul> Warnings/errors as per 147434–080–P1: <ul style="list-style-type: none"> <li>• Error displayed that certificate has expired</li> <li>• Warning displayed that certificate is nearing expiry (within 60 days).</li> </ul>
View: Private Key	No	Private key must not be viewable
Export: Formats	Yes	Private key must not be exportable Export formats: <ul style="list-style-type: none"> <li>• DER format. '.cer' '.der' and '.crt' file extension.</li> <li>• PEM format. '.cer' '.pem' and '.crt' file extension.</li> <li>• PKCS#12 (optional)</li> </ul>

### Related links

[Certificate Support](#) on page 586

### Trusted Certificate Store

Feature	Support	Notes
Import: RSA 1024-4096 key size	Yes	RSA 1024, 2048 and 4096 bit public keys must be supported. Any other sizes are optional. Import of RSA public key less than 1024 or greater than 4096 bits to be rejected with an informative error.
Import: Optional private key	Yes	No private key will actually be imported. Informative message (neither warning or error) that private key has not been imported

*Table continues...*

Feature	Support	Notes
Import: Certificate checks	Yes	Minimum checks for: <ul style="list-style-type: none"> <li>• Version (v3)</li> <li>• Start + end (present)</li> <li>• Subject Name (present)</li> <li>• Issuer Name (present)</li> <li>• Data integrity (e.g. hash)</li> </ul> Reject + descriptive error if a check fails
Import: Certificate up to 4KB	Yes	Certificates can be varying sizes
Import: Formats	Yes	<ul style="list-style-type: none"> <li>• DER format. '.cer' '.der' and '.crt' file extension.</li> <li>• PEM format. '.cer' '.pem' and '.crt' file extension.</li> <li>• PKCS#12 format. '.p12' and '.pfx' file extension. With or without password.</li> <li>• Pasted from clipboard in PEM format (optional)</li> </ul>
Import: Up to 19 other certificates in same file	Yes	All included certificates, up to 20 total. More than 20 in one file can be optionally supported.
View: TCS Certificate	Yes	Minimum viewable attributes (From CEC016: 147434–030–P1): <ul style="list-style-type: none"> <li>• Serial Number</li> <li>• Subject Name</li> <li>• Issuer Name</li> <li>• Validity Period (that includes notBefore and notAfter dates)</li> <li>• Thumbprint (Hash of the certificate)</li> <li>• Subject Alternative Names</li> <li>• Key Usage Extensions</li> <li>• Extended Key Usage</li> </ul> Warnings/errors as per 147434–080–P1: <ul style="list-style-type: none"> <li>• Error displayed that a certificate has expired</li> <li>• Warning displayed that a certificate is nearing expiry (within 60 days).</li> </ul>
Export: Formats	Yes	Export formats: <ul style="list-style-type: none"> <li>• DER format. '.cer' '.der' and '.crt' file extension.</li> <li>• PEM format. '.cer' '.pem' and '.crt' file extension.</li> <li>• PKCS#12 (optional)</li> </ul>

**Related links**

[Certificate Support](#) on page 586

## Signing Certificate

Feature	Support	Notes
Import: RSA 1024-4096 key size	Yes	RSA 1024, 2048 and 4096 bit public keys must be supported. Any other sizes are optional.  Import of RSA public key less than 1024 or greater than 4096 bits to be rejected with an informative error.
Import: Must have private key	Yes	Must be supplied.  Reject and informative error that private key has not been supplied
Import: Certificate checks	Yes	Minimum checks for: <ul style="list-style-type: none"> <li>• Version (v3)</li> <li>• Start + end (present)</li> <li>• Subject Name (present)</li> <li>• Issuer Name (present)</li> <li>• Data integrity (e.g. hash)</li> </ul> Reject and informative error if a check fails
Import: Certificate up to 4KB	Yes	Certificates can be varying sizes
Import: Formats	Yes	<ul style="list-style-type: none"> <li>• PKCS#12 format. '.p12' and '.pfx' file extension. With or without password. This shall be the preferred/default option</li> <li>• PEM format. '.cer' '.pem' and '.crt' file extension.</li> <li>• Pasted from clipboard in PEM format (optional)</li> </ul> NOTE that ONLY PKCS#12 file format is acceptable according to 147434-030-P1, however we cannot control what format customers receive their certificates in, hence all should be supported
Import: Other certificates in same file	No	Informative warning that other certificates have not been imported

*Table continues...*

Feature	Support	Notes
View: TCS Certificate	Yes	Minimum viewable attributes (From CEC016: 147434–030–P1): <ul style="list-style-type: none"> <li>• Serial Number</li> <li>• Subject Name</li> <li>• Issuer Name</li> <li>• Validity Period (that includes notBefore and notAfter dates)</li> <li>• Thumbprint (Hash of the certificate)</li> <li>• Subject Alternative Names</li> <li>• Key Usage Extensions</li> <li>• Extended Key Usage</li> </ul> Warnings/errors as per 147434–080–P1: <ul style="list-style-type: none"> <li>• Error displayed that certificate has expired</li> <li>• Warning displayed that certificate is nearing expiry (within 60 days).</li> </ul>
Renew existing:	Yes	Regenerate CA keeping all keys and other contents same except: <ul style="list-style-type: none"> <li>• notBefore and notAfter dates</li> <li>• Serial Number</li> <li>• Thumbprint (Hash of the certificate)</li> <li>• ??</li> </ul> Can this be done to imported CAs or just internally generated ones?
Create new:	Yes	Regenerate CA, including keys
Export: Formats	Yes	Private key must not be exportable Export formats: <ul style="list-style-type: none"> <li>• DER format. '.cer' '.der' and '.crt' file extension.</li> <li>• PEM format. '.cer' '.pem' and '.crt' file extension.</li> <li>• PKCS#12 (optional)</li> </ul>

**Related links**

[Certificate Support](#) on page 586

**Certificate File Import**

File Content	Identity Certificate Import Command	Trusted Certificate Import Command	Signing Certificate Import Command	Notes
DER				

*Table continues...*



File Content	Identity Certificate Import Command	Trusted Certificate Import Command	Signing Certificate Import Command	Notes
DER: 1 certificate	No – attempt rejected with 'Invalid certificate format (DER)'	Yes – attempt accepted with 'N certificate(s) imported into Trusted Certificate Store'	No – attempt rejected with 'Invalid certificate format (DER)'	
DER: Any other content	No – attempt rejected with 'Invalid content (DER)'	No – attempt rejected with 'Invalid content (DER)'	No – attempt rejected with 'Invalid content (DER)'	
PKCS#12				
PKCS#12: 1 certificate + private key	Yes – attempt accepted with 'Certificate import successful'  Certificate/key imported as ID certificate	No – p12/pfx should not be offered for file selection	Yes – attempt accepted with 'Certificate import successful'	
PKCS#12: 1 certificate + private key, 1 or more other certificates	Yes – attempt accepted with 'Certificate import successful'  Certificate/key imported as ID certificate  Other certificates imported into TCS with 'N certificate(s) imported into Trusted Certificate Store'	No – p12/pfx should not be offered for file selection	Yes – attempt accepted with 'Certificate import successful'  Certificate/key imported as signing certificate  Other certificates ignored	At least 20 certificates supported in the same file
PKCS#12: Any other content	No – attempt rejected with 'Invalid content (PKCS#12)'	No – p12/pfx should not be offered for file selection	No – attempt rejected with 'Invalid content (PKCS#12)'	
PEM: 1 Certificate	No – attempt rejected with 'Invalid certificate format (PEM – no private key)'	Yes – attempt accepted with 'N certificate(s) imported into Trusted Certificate Store'	No – attempt rejected with 'Invalid certificate format (PEM – no private key)'	Certificate can be encrypted on unencrypted
<b>PEM</b>				

Table continues...

File Content	Identity Certificate Import Command	Trusted Certificate Import Command	Signing Certificate Import Command	Notes
PEM: N Certificate	No – attempt rejected with 'Invalid certificate format (PEM – no private key)'	Yes – attempt accepted with 'N certificate(s) imported into Trusted Certificate Store'	No – attempt rejected with 'Invalid certificate format (PEM – no private key)'	At least 20 certificates supported in the same file  Certificate can be encrypted on unencrypted
PEM: 1 Certificate + private key	Yes – attempt accepted with 'Certificate import successful'  Certificate/key imported as ID certificate	No – attempt rejected with 'Invalid certificate format (PEM)'	Yes – attempt accepted with 'Certificate import successful'  Certificate/key imported as signing certificate	Certificate or Key can be encrypted on unencrypted
PEM: 1 Certificate + private key, 1 or more other certificates.  Private key <u>must</u> be before or after the first certificate	Yes – attempt accepted with 'Certificate import successful'  Certificate/key imported as ID certificate.  Other certificates imported into TCS with 'N certificate(s) imported into Trusted Certificate Store'	Yes – attempt accepted with 'N certificate(s) imported into Trusted Certificate Store'  First certificate and private key ignored	Yes – attempt accepted with 'Certificate import successful'  Certificate/key imported as signing certificate  Other certificates ignored	Private key <u>must</u> be before or after the first certificate  Certificate or Key can be encrypted on unencrypted
PEM: Any other content	No – attempt rejected with 'Invalid content (PEM)'	No – attempt rejected with 'Invalid content (PEM)'	No – attempt rejected with 'Invalid content (PEM)'	Option to include more detail of the rejection cause.e.g. 'Cannot detect Identity Certificate', 'Too many private keys', 'Unrecognized header' etc.

**Related links**

[Certificate Support](#) on page 586

---

## On-boarding

On-boarding refers to the configuration of an SSL VPN service in order to enable remote management services to customers, such as fault management, monitoring, and administration. You must use the Web Manager client to configure on-boarding.

For full details on how to configure and administer SSL VPN services, refer to *Deploying Avaya IP Office™ Platform SSL VPN Services*.

The procedure provided below configures IP Office for Avaya support services. Avaya partners can also use an SSL VPN to provide support services. See the chapter “Configuring an Avaya Partner SSL VPN using an SDK” in *Deploying Avaya IP Office™ Platform SSL VPN Services*.

### Related links

[Configuring an SSL VPN using an on-boarding file](#) on page 595

---

## Configuring an SSL VPN using an on-boarding file

The on-boarding XML file is available from Avaya. It contains the settings required to establish a secure tunnel between IP Office and an AVG server. When you import the on-boarding XML file, it applies the settings and installs one or multiple TLS certificates.

When you configure the SSL VPN service on a new system, you must begin by generating an inventory file of the IP Office system. When you register your IP Office system, the inventory file that you generated is uploaded to the GRT and the inventory data is populated in the Avaya Customer Support (ACS) database. After you enable remote support, you can download the XML on-boarding file from the GRT web site and upload it into your IP Office system.

The on-boarding process configures:

- SSL VPN service configuration
- short codes for enabling and disabling the SSL VPN service
- SNMP alarm traps
- one or more TLS certificates in the IP Office trusted certificate store

Perform this procedure using the Avaya IP Office Web Manager client.

### **Warning:**

The process of 'on-boarding automatically creates an SSL VPN service in the system configuration when the on-boarding file is uploaded to the system. Care should be taken not to delete or modify such a service except when advised to by Avaya.

### **Before you begin**

Before you begin, you must have the hardware codes and catalog description of your IP Office system. For example, “IP OFFICE 500 VERSION 2 CONTROL UNIT TAA” is a hardware code and catalog description.

## Procedure

1. Select **Tools > On-boarding**.

The On-boarding dialog box displays.

2. If the hardware code for your IP Office system ends with the letters TAA, select the checkbox next to the prompt **Are you using TAA series hardware?**
3. Click **Get Inventory File** to generate an inventory of your IP Office system.

4. Click **Register IP Office**.

A browser opens and navigates to the GRT web site.

5. Log in to the web site and enter the required data for the IP Office system.
6. Select **Remote Support** for the IP Office system.
7. Click **Download** and save the on-boarding file.

8. Browse to the location where you saved the on-boarding file and click **Upload**.

A message displays to confirm that the on-boarding file has installed successfully.

## Related links

[On-boarding](#) on page 595

---

# System Date and Time

## How Does the System Get The Date and Time

In most case, the system is configured during installation to automatically get the date and time from a trusted time source.

- **Linux based servers:** The date and time source settings are set through the **Settings | System | Data and Time** settings of the server's **Platform View** menus. The possible date and time options are:
  - **SNTP:** Use the date and time provided by an SNTP time server. The UTC time provided by the time server is adjusted using the server's timezone setting. If you have a network of servers, it is typical to set the primary server to use an external SNTP source and all other servers are set to use SNTP from the primary server's own address.
  - **Manual:** Get the date and time from values entered through the platform view menu.
- **IP500 V2 Servers:** These systems are configured through their **Time Setting Config Source** settings (**System | System**). The options supported are:
  - **Voicemail Pro/Manager:** Get the date and time from the Windows PC running either the Voicemail Pro or IP Office Manager applications. This option requires the application to be running when the IP Office is started and for regular time updates.
  - **SNTP:** Get the date and time from an SNTP time server in the same way as Linux based systems above do.

- **None:** Get the date and time from values entered via a system phone. See [Manually Setting the System Time](#) below.

## Locations

In a network of systems, it may be necessary for some servers and or extensions, to have different time and date settings in order to match where they are physically located. This can be done by adding **Location** entries to the IP Office configuration <<<need link>>>. Each location can include a time offset from the UTC time and a set of DST settings (see below) for the location. Where necessary, system's and extension's can then be associated with those locations.

## Automatic Daylight Saving Adjustments

It may be necessary to apply daylight saving time (DST) changes at certain times of the year. How this is done depends on the type of IP Office server and which time source it has been configured:

- **Linux-based Server:** Daylight saving adjustments are applied to the SNTP time by defining a **Location** for the system, see above. The location settings include the required DST settings for that location.
- **IP500 V2 Server:** The method of applying DST depends on the time source being used by the server.
  - **Voicemail Pro/Manager:** If the system is obtaining its time from a PC running Voicemail Pro or IP Office Manager, then that PC needs to be configured to automatically do its own
  - **SNTP/None:** The **System | System** menu includes settings for specifying when DST is applied.

## How Does the System Use the Date and Time

For files stored on memory cards the system uses the UTC time. For other activities such as call logs, SMDR records, time display on phones; the local time (UTC + any offsets) is used.

## Manually Setting the System Time

For IP500 V2 systems set to no time server source, date and time changes can be done though a phone if the phone user has been give **System Phone Rights** (see [System Phone Features](#) on page 727). The user's login code is used to restrict access to the time and date settings on the phone. How the user accesses the date/time settings depends on the type of phone:

- **1400, 1600, 9500 and 9600 Series Phones:** These phones (excluding the 1403/1603 models) can set the system time and date settings by selecting **Features | Phone User | System Administration**. If the system has been configured with a time server, this option can still used to display time and date information but cannot be used to change it.
- **Other Phones:** On 2410, 2420, 4412, 4424, 4612, 4624, 4610, 4620, 4621, 5410, 5420, 5610, 5620, 5621, 6412 and 6424 phone, a **Self Admin 2** button can be used to set the date and time. See Self Administer topic in *Administering Avaya IP Office™ Platform with Web Manager*.

---

# Configuring Time Profiles

Time profiles are configured on **Time Profile | Time Profile**

Time Profiles are used by different services to change their operation when required. In most areas where time profiles can be used, not setting a time profile is taken as meaning 24-hour operation.

Time profiles consist of recurring weekly patterns of days and times when the time profile is in effect.

Time profiles can include time periods on specified calendar days when the time profile is in effect. Calendar records can be entered for the current and following calendar year.

For a Server Edition network, these settings can be configured at the network level and are then automatically replicated in the configuration of all systems in the network. They can only be seen and edited at the individual system configuration level if record consolidation is switched off.

Time profiles are used by the following record types.

### **Hunt Group:**

A time profile can be used to determine when a hunt group is put into night service mode. Calls then go to an alternate Night Service Fallback group if set, otherwise to voicemail if available or busy tone if not.

Setting and clearing hunt group night service can be done using either manual controls or using a system time profile. The use of both methods to control the night service status of a particular hunt group is not supported.

For automatic voice recording, a time profile can be used to set when voice recording is used.

### **User:**

- Users being used for Dial In data services such as RAS can have an associated time profile that defines when they can be used for that service.
- Users can be associated with a working hours and an out of hours user rights. A time profile can then be used to determine which user rights is used at any moment.
- For automatic voice recording, a time profile can be used to set when that voice recording is used.
- For mobile twinning, a time profile can be used to define when twinning should be used.

### **Incoming Call Route:**

Incoming call routes can also use time profiles to specify when calls should be recorded. Multiple time profiles can be associate with an incoming call route, each profile specifying a destination and fall back destination.

### **ARS:**

ARS forms use time profile to determine when the ARS form should be used or calls rerouted to an out of hours route.

### **Account Code:**

Account Codes can use automatic voice recording triggered by calls with particular account codes. A time profile can be used to set when this function is used.

### **Auto Attendant :**

Embedded voicemail auto attendants can use time profiles to control the different greetings played to callers.

**Service:**

- A Service can use time profiles in the following ways:
- A time profile can be used to set when a data service is available. Outside its time profile, the service is either not available or uses an alternate fallback service if set.
- For services using auto connect, a time profile can be used to set when that function is used. See [Service | Autoconnect](#).

**Related links**

[Overriding a Time Profile](#) on page 599

---

## Overriding a Time Profile

You can use the **Time Profile | Manual Override** setting to manually override a time profile. The override settings allow you to mix timed and manual settings.

The override options are as follows:

- **Set Time Profile Active Until Next Timed Inactive**

Use for time profiles with multiple intervals. Make the time profile active until the next inactive interval.

- **Set Time Profile Inactive Until Next Timed Active**

Use for time profiles with multiple intervals. Make the time profile inactive until the next active interval.

- **Set Time Profile Latch Active**

Set the time profile to active. Timed inactive periods are overridden and remain active.

- **Set Time Profile Latch Inactive**

Set the time profile to inactive. Timed active periods are overridden and remain active.

The illustration below provides an example of each override setting.

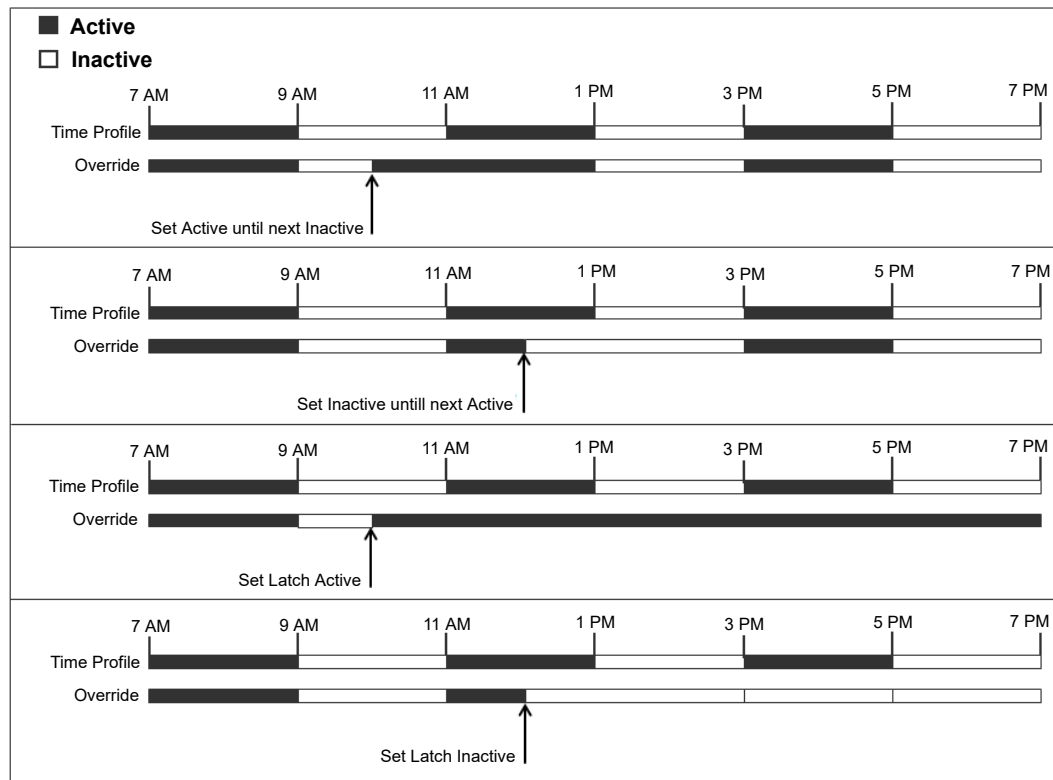

A time profile can be overridden using the following methods.

- Using the **Override** settings on the Time Profile configuration page.
- Configure short codes for the time profile. See the description for the “Set Time Profile” short code.
- Configure the Time Profile button action for the time profile. See the description for the “Time Profile” button action.

**Related links**

[Configuring Time Profiles](#) on page 597

---

## Working with Templates

IP Office supports a number of template options. The settings for the following types of configuration items can be saved as template files. New records of those types can then be created from the template file.

- User (.usr)
- Extension (H.323, SIP, IP DECT) (.ext)



- Group (.grp)
- Service (.ser)
- Tunnel (.tnlt)
- Firewall Profile (.fpr)
- Time Profile (.tpr)
- IP Route (.ipr)
- ARS (.ars)
- Line (H.323, SIP, IP DECT) (.lne)

### Saving Template files

**Standard Mode Systems:** Standard mode systems export templates to a local folder on the PC where Manager is running. Templates are stored in the default folder `C:\Program Files (x86)\Avaya\IP Office\Manager\manager_files\template`.

**Server Edition Systems:** Server Edition system templates are stored on the Primary Server. When the system configuration is opened, those templates are downloaded from server to the default folder above. When the configuration is saved, the templates are uploaded back to server.

#### **Caution:**

Due to the difference in operation detailed above, any non-Server Edition templates stored in the default folder, are liable to be overwritten when a Server Edition configuration is loaded. Therefore, if you administer both Server Edition and non-Server Edition system, you need to ensure that you store the non-Server Edition templates in a directory other than the default directory.

For Server Edition, if you are working with an offline configuration, any templates created are deleted after you close Manager.

### Tested SIP Trunk Templates

The SIP trunk services from selected SIP providers are tested as part of the Avaya DevConnect program. The results of such testing are published as Avaya Application Notes available from the Avaya DevConnect web site (<https://devconnect.avaya.com>).

#### Related links

[Importing Trunk Templates](#) on page 601

[Creating a Template in Manager](#) on page 602

[Creating a New Record from a Template in Manager](#) on page 602

[Creating an Analog Trunk Template in Manager](#) on page 603

[Creating a New Analog Trunk from a Template in Manager](#) on page 603

[Applying a Template to an Analog Trunk](#) on page 604

---

## Importing Trunk Templates

For Standard Mode, before you can use templates from another source, they must be placed in the `Manager\Templates` directory. Use this procedure to import a template from another source.

### Procedure

1. Select **Tools | Import Templates in Manager**.
2. Browse to the current folder containing the templates that you want to import and select that folder.
3. Click **OK**.
4. Any template files in the folder will be copied to the correct Manager sub-folder.

### Related links

[Working with Templates](#) on page 600

---

## Creating a Template in Manager

You can create a template from an existing record.

The options **New From Template** and **Export as Template** are available by:

- right clicking on the record type in the Navigation pane
- right clicking on a record in the Group pane
- using the Details Toolbar in the Details pane

This procedure uses the Group Pane.

### Procedure

1. In the Navigation pane, select a record type.
2. In the Group pane, right click on the record on which you want to base your template and select **Export as Template**.
3. The **Save As** window opens at the default template folder. Enter a name for the template.  
A default extension is applied. For example, user templates are saved with the file extension `.usr` and extension templates are saved with file extension `.ext`.
4. Click **Save**.

You can now create new records using the template.

### Related links

[Working with Templates](#) on page 600

---

## Creating a New Record from a Template in Manager

You can use a template to create additional records.

The options **New from Template** and **Export as Template** are available by:

- right clicking on the record type in the Navigation pane

- right clicking on a record in the Group pane
- using the Details Toolbar in the Details pane

This procedure uses the Group Pane.

### Procedure

1. In the Navigation pane, select a record type.
2. In the Group pane, right click on the record on which you want to base your template and select **New from Template > Open from file**.

Manager lists available templates stored in the default directory.

3. In the Open window, select the template file and click **Open**.
4. For some record types, the Import Templates window opens.
  - a. Enter the number of records to create in the **Number of records to import** field.
  - b. In the **Start with index** field, enter starting index number for the new records.
  - c. Click **OK**.

### Related links

[Working with Templates](#) on page 600

## Creating an Analog Trunk Template in Manager

You can create an analog trunk template from an existing trunk..

### Procedure

1. In the Navigation pane, select **Line**.
2. In the Group pane, right click on the record on which you want to base your template and select **Generate Analog Trunk Template**.
3. In the Analog Trunk Template window, you can adjust the settings if required. Click **Export**.
4. In the Template Type Selection window, select the **Service Provider** and then click **Create Template**.
5. In the Browse for Folder window, select `Program Files\Avaya\IP Office\Manager\manager_files\template`.
6. Click **OK**.

### Related links

[Working with Templates](#) on page 600

## Creating a New Analog Trunk from a Template in Manager

You can create a new analog trunk from a template.

### Procedure

1. In the Navigation pane, right click **Line** and select **New from Template > Open**.
2. In the Open window, select a template and click **Open**.
3. In the Template Type Selection window, select the **Service Provider** and then click **Create**.

### Related links

[Working with Templates](#) on page 600

---

## Applying a Template to an Analog Trunk

You can apply an analogue trunk template to existing analogue trunks.

### Note:

You must reboot the system for any changes to be applied.

### Procedure

1. In the group pane, right click on the analogue trunk and select **Copy Setting from Template**.
2. The template and trunk selection menu is displayed.
3. In the Template Type Selection window, use the **Service Provider** drop-down to select the required template.
4. Select the trunks to which you want the template to be applied.
5. Click on **Copy Settings**.

### Related links

[Working with Templates](#) on page 600

---

## Centralized System Directory

Directory services can be used to import directory records (names and numbers) from external sources. These sets of records are regularly re-imported.

Directory records can come from the following sources:

- **LDAP Import:** The system can import LDAP records for use within directories shown by user phones and applications. LDAP import is configured through the **System | Directory Services | LDAP** form. The LDAP used is LDAP Version 2.
- **HTTP Import :** Systems are able to import the directory records from another system using HTTP. HTTP import is configured through the **System | Directory Services | HTTP** form by specifying an IP address or multi-site network connection. The records imported can be any

or all of the following record types held by the system from which the records are being imported: LDAP imported records, HTTP imported records, configuration records.

- **System Directory Records (Configuration records):** Records can be entered directly into the system configuration through the **Directory | Directory Entry** form. System directory records override matching LDAP/HTTP imported records.

Users with system phone rights (see [System Phone Features](#) on page 727) and a phones with a **CONTACTS** button can add, delete and edit the system directory records of the system on which they are logged in. They cannot edit LDAP or HTTP imported records.

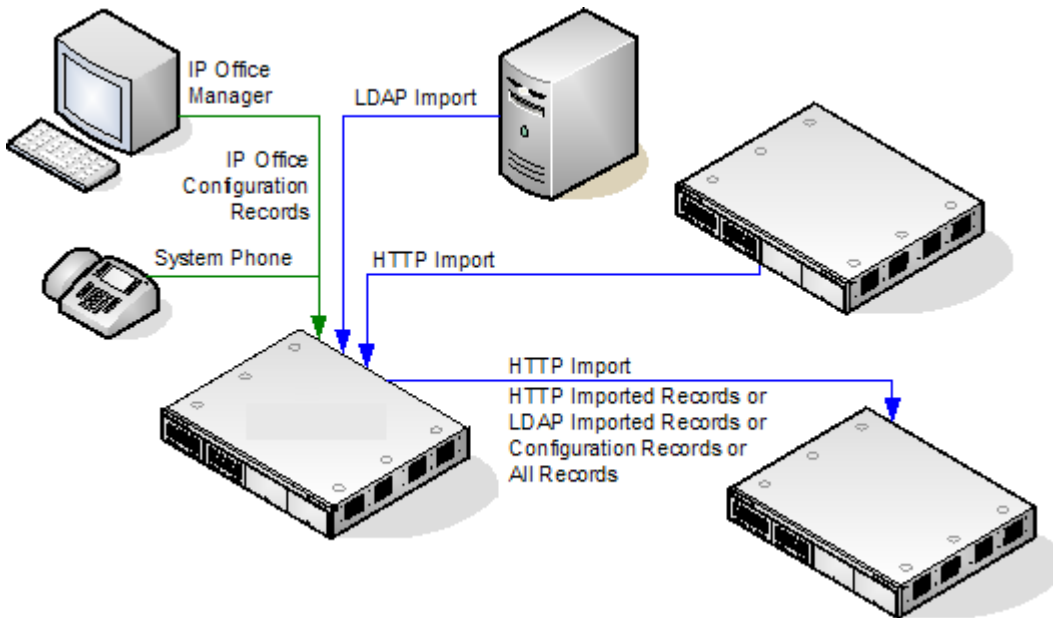

### Server Edition Directory Operation

For a Server Edition network, these settings can only be configured at the network level and they are stored in the configuration of the Primary Server. All other systems in the network are configured to share the directory settings of the Primary Server through the settings at **System | Directory Services | HTTP**.

### Directory Record Capacity

The directory capacity depends on the type of system. The figures below are applicable for Release 10.0.

	System	Number of Directory Records			Total Number of Directory Records
		Configuration	LDAP Import	HTTP Import	
Standalone Systems	IP500 V2	2,500	10,000	10,000	10,000
Server Edition	Primary Server	10,000	10,000	10,000	10,000
	Secondary Server	–	–	10,000	10,000

*Table continues...*

	System	Number of Directory Records			Total Number of Directory Records
		Configuration	LDAP Import	HTTP Import	
	Expansion System (L)	–	–	10,000	10,000
	Expansion System (V2)	–	–	10,000	10,000

## Directory Dialing

Directory numbers and names are displayed by user applications such as SoftConsole. The method by which these directories are searched and used depends on the application. Refer to the appropriate user guide.

Directory entries used for dialing can contain **()** and **—** characters in the number. Those characters are ignored in the dialled output. Directory entries containing **?** in the number (used for directory name matching) are not included in the directory for dialing.

Directory names are also viewable through the **Dir** or **Contacts** function on many Avaya phones. They allow the user to select the name in order to dial its associated number.

The directory function groups directory records shown to the phone user into several categories, for example; system, personal, users and groups. Depending on the phone or application, the user may be able to select the category currently displayed. In some scenarios, the categories displayed may be limited to those supported for the action being performed by the user. The typical categories are:

- **External:** Directory records from the system configuration. This includes HTTP and LDAP imported records.
- **Groups:** Groups on the system. If the system is in a multi-site network, it will also include groups on other systems in the network.
- **Users or Index:** Users on the system. If the system is in a multi-site network it will also include users on other systems in the network.
- **Personal:** Available on 1400, 1600, 9500 and 9600 Series phones. These are the user's personal directory records stored within the system configuration.

On phones that support **Dir** or **Contacts**, the user can filter the currently displayed set of directory names by dialing on their keypad. Additional dialing applies a progressive filter. For example, if the user presses the 5 key (JKL), only names with some part beginning with J, K or L remain listed. If the user then presses the 2 key (ABC), only names with some part beginning with JA, JB, JC, KA, etc. remain listed. As the users presses more keys on their phone, the number of remaining matches reduces.

By default the letter matching is performed simultaneously against all parts of the directory name, ie. first, middle and last name. However, this behavior can be modified for all users using a NoUser source number.

## Speed Dialing

On M-Series and T-Series phones, a **Speed Dial** button or dialing **Feature 0** can be used to access personal directory records using the record's index number.

- **Personal:** Dial **Feature 0** followed by \* and the 2-digit index number in the range 01 to 99.

- **System:** Dial **Feature 0** followed by 3-digit index number in the range 001 to 999.
- The **Speed Dial** short code feature can also be used to access a directory speed dial using its index number from any type of phone.

### Caller Directory Name Matching

Directory records are also used to associate a name with the dialled number on outgoing calls or the received CLI on incoming calls. When name matching is being done, a match in the user's personal directory overrides any match in the system directory. Note that some user applications also have their own user directory.

- The ( ) and — characters are not used for directory name matching. Directory entries with those characters are ignored for name matching.
- A ? character can be used to match any digit or digits. For example 91?3 will match 9123. Typically a single ? is used at the end of a known dialing string such as an area code.
- The best match is used, determined by the highest number of matched digits.
- There is no minimum number of matches. For example, a directory entry of 9/External can be used to match any external call unless it has a better match.

### Other Name Sources:

- SoftConsole has its own directories which are also used for name matching. Matches in the application directory can lead to the application displaying a different name from that shown on the phone.
- Name matching is not performed when a name is supplied with the incoming call, for example QSIG trunks. On SIP trunks the use of the name matching or the name supplied by the trunk can be selected using the **Default Name Priority** setting (**System | Telephony | Telephony**). This setting can also be adjusted on individual SIP lines to override the system setting.
- Directory name matching is not supported for DECT handsets. For information on directory integration, see *IP Office DECT R4 Installation*.

### Imported Records

Imported directory records are temporary until the next import refresh. They are not added to the system's configuration. They cannot be viewed or edited using Manager or edited by a system phone user. The temporary records are lost if the system is restarted. However the system will request a new set of imported directory records after a system restart. The temporary records are lost if a configuration containing Directory changes is merged. The system will then import a new set of temporary records without waiting for the **Resync Interval**. If an configuration record is edited by a system phone user (see [System Phone Features](#) on page 727) to match the name or number of a temporary record, the matching temporary record is discarded.

### Importation Rules:

When a set of directory records is imported by HTTP or LDAP, the following rules are applied to the new records:

- Imported records with a blank name or number are discarded.
- Imported records that match the name or number of any existing record are discarded.
- When the total number of directory records has reached the system limit, any further imported records are discarded.

For capacity information, see the description for the **Directory** tab.

---

## Advice of Charge

The system supports advice of charge (AOC) on outgoing calls to ISDN exchanges that provide AOC information. It supports AOC during a call (AOC-D) and at the end of a call (AOC-E). This information is included in the SMDR output.

AOC is only supported on outgoing ISDN exchange calls. It is not supported on incoming calls, reverse charge calls, QSIG and non-ISDN calls. Provision of AOC signalling will need to be requested from the ISDN service provider and a charge may be made for this service.

For users, display of AOC information is only supported on T3 phones and T3 IP phones.

The user who makes an outgoing call is assigned its charges whilst they are connected to the call, have the call on hold or have the call parked.

If AOC-D is not available, then all indicated by AOC-E are assigned to the user who dialed the call.

If AOC-D is available:

- If the call is transferred (using transfer, unpark or any other method) to another user, any call charges from the time of transfer are assigned to the new user.
- If the call is manually transferred off-switch, the call charges remain assigned to the user who transferred the call.
- If the call is automatically forwarded off switch, subsequent call charges are assigned to the forwarding user.
- AOC-D information will only be shown whilst the call is connected. It will not be shown when a call is parked or held.
- Call charges are updated every 5 seconds.

For conference calls all call charges for any outgoing calls that are included in the conference are assigned to the user who setup the conference, even if that user has subsequently left the conference.

Enabling AOC Operation

1. **Set the System Currency** The Default Currency (System | Telephony | Telephony) setting is by default set to match the system locale. Note that changing the currency clears all call costs stored by the system except those already logged through SMDR.
2. **Set the Call Cost per Charge Unit for the Line** AOC can be indicated by the ISDN exchange in charge units rather than actual cost. The cost per unit is determined by the system using the **Call Cost per Charge Unit** setting which needs to be set for each line. The values are 1/10,000th of a currency unit. For example if the call cost per unit is £1.07, a value of 10700 should be set on the line.



3. **Applying a Call Cost Markup** It may be a requirement that the cost applied to a user's calls has a mark-up (multiplier) applied to it. This can be done using the Call Cost Markup (User | Telephony | Call Settings) setting. The field is in units of 1/100th, for example an entry of 100 is a markup factor of 1.
4. **Enable User AOC Display** By default users do not see call charges. The **Display Charges** setting is used to switch this option on or off. Note that the display of AOC information is only supported on T3 phones.

#### AOC Short Codes

A number of short code features exist that can be used with AOC. These features can only be used with T3 phones.

**AOC Previous Call** Displays the call costs of the user's previous call if AOC information was provided with that call.

**AOC Total** Display the cumulative total cost of the user's calls for which AOC information is available.

**AOC Reset Total** Set the cumulative total (units and cost) for the user's calls back to zero.

---

## Emergency Call

Manager expects that the configuration of each system should contain at least one short code that is set to use the **Dial Emergency** feature. If no such short code is present in the configuration then Manager will display an error warning. The importance of the **Dial Emergency** feature is that it overrides all external call barring that may have been applied to the user whose dialing has been matched to the short code. You must still ensure that no other short code or extension match occurs that would prevent the dialing of an emergency number being matched to the short code.

The short code (or codes) can be added as a system short code or as an ARS record short code. If the **Dial Emergency** short code is added at the solution level, that short code is automatically replicated into the configuration of all servers in the network and must be suitable for dialing by users on all systems. Separate **Dial Emergency** short codes can be added to the configuration of an individual system. Those short codes will only be useable by users currently hosted on the system including users who have hot desked onto an extension supported by the system.

### Determining the Caller's Location

It is the installers responsibility to ensure that a **Dial Emergency** short code or codes are useable by all users. It is also their responsibility to ensure that either:

the trunks via which the resulting call may be routed are matched to the physical location to which emergency service will be dispatched

or

the outgoing calling line ID number sent with the call matches the physical location from which the user is dialing.

## Hot Desking Users

In addition to the location requirements above, you must also remember that for users who hot desk, from the networks perspective the user's location is that of the system hosting the extension onto which the user is currently hot desked. If that is an IP extension then that location is not necessarily the same as the physical location of the server.

## Emergency call setup

Routing of emergency calls is based on a call resolving to a Dial Emergency short code. Based on the location value for the extension making the call, routing is performed as configured in the Emergency ARS. Emergency calls have maximum priority and are not delayed in any way.

## Configuring emergency call routing

Create a Dial Emergency system short code. See Dial Emergency.

Note that the **Line Group ID** value in the Dial Emergency short code is the fallback route. If the system cannot find a location or an Emergency ARS, it will try to use the **Line Group ID** to route the call.

1. Create an ARS containing a Dial short code or a Dial Emergency short code. See ARS.
2. Create a Location and set the **Emergency ARS** to the ARS created in step 2. See Location.
3. Open the **Extn** tab for an extension that will use the location defined in step 3 and set the **Location** value to the location defined in step 3. Note that once you define a location, you must set a system **Location** value on the System | System page.

For non-IP based extensions, the system location value is used as the default. For IP based extensions, the location value is set to Automatic. An attempt is made to match the extension's IP address to the subnet configured in the location. If the match is cannot be made, the location value defaults to the system location value.

From the extension used in step 3, dial the Dial Emergency short code. IP Office checks the location value and determines the emergency ARS set for the location. Once the emergency ARS is found, IP Office will try to match the Telephone Number in the Dial Emergency short code to a short code in the ARS and use it to make the emergency call.

---

# Fax Support

## Fax on IP500 V2 Systems

IP500 V2 systems can terminate T38 fax calls. For a system with an IP500 VCM, IP500 VCM V2 or IP500 Combo cards, **T38** or **G.711** can be used for fax transmission. Each fax call uses a VCM channel unless it is a T38 fax call between compatibly configured call legs. A SIP line or extension must support Re-Invite.

**T38 Fallback** can also be specified. On outgoing fax calls, if the called destination does not support T38, a re-invite is sent for fax transport using **G.711**.

## Configuring Fax on SIP Lines and Extensions:

To configure Fax on SIP Lines and Extensions:

1. On the **VoIP** page for the line or extension, set **Re-Invite Supported** to **On** in order to enable **Fax Transport Support**
2. Select a value in the **Fax Transport Support** field.

Note the following:

- Direct media is supported.
- If **Fax Transport Support** is set to **T38** or **T38 Fallback**, the T38 Fax page is available. The T38 Fax page provides detailed T38 configuration options.

### **Configuring Fax on an IP Office Line:**

Within a multi-site network, **Fax Transport Support** can also be enabled on the IP Office Lines between the systems. This allows fax calls at one system to be sent to another system.

To configure Fax on an IP Office Line:

1. Set **IP Office Line | Line Settings | Networking Level** to **SCN**.
2. Set **IP Office Line | VoIP | Fax Transport Support** to **Fax Relay**.

### **Related links**

[Server Edition T38 Fax Support](#) on page 612

---

## Server Edition T38 Fax Support

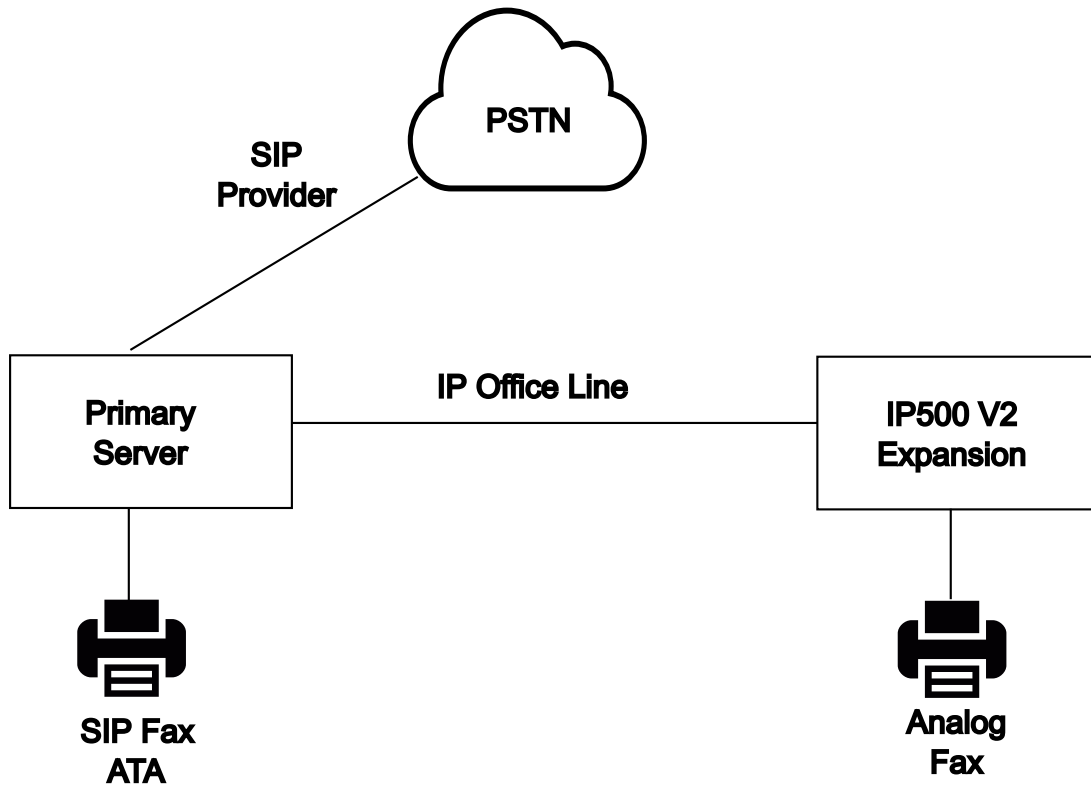

□

### Fax on Server Edition Linux Servers

IP Office Linux servers cannot terminate T38 fax and therefore, T38 is negotiated end-to-end. When a SIP ATA fax is connected to an IP Office Linux server, the system directly relays negotiation between the SIP ATA Fax and the SIP provider.

### Configuring Fax on SIP Lines and Extensions:

To configure Fax on SIP Lines and Extensions, on the **VoIP** page for the SIP line or extension:

1. Set **Re-Invite Supported** to **On** in order to enable **Fax Transport Support**.
2. Select a value in the **Fax Transport Support** field.

Note the following.

- Direct media is supported.
- The **T38 Fax** page is not available.

### Fax on Server Edition IP500 V2 Expansion Systems

Since an IP500 V2 system can terminate T38 fax, an analog fax can be connected to an IP500 V2 Expansion system. Fax transport is configured on the IP Office Line connecting the IP500 V2 system to the Server Edition network.

### Configuring Fax on an IP Office Line:

To configure Fax on an IP Office Line, on the **Line | IP Office Line | VoIP Settings** page, select a value in the **Fax Transport Support** field. **Fax Relay** is not supported.

Note the following.

- Direct media is supported.
- The **T38 Fax** page is not available.

#### Related links

[Fax Support](#) on page 610

---

## Caller Display

Caller display displays details about the caller and the number that they called. On internal calls, the system provides this information. On external calls it uses the Incoming Caller Line Identification (ICLID) received with the call. The number is also passed to system applications and can be used for features such as call logging, missed calls and to make return calls.

Analog extension can be configured for caller display via the system configuration (Extension | Extn | Caller Display Type).

**Adding the Dialing Prefix** Some systems are configured to require a dialing prefix in front of external numbers when making outgoing calls. When this is the case, the same prefix must be added to the ICLID received to ensure that it can be used for return calls. The prefix to add is specified through the Prefix field of each line.

**Directory Name Matching** The system configuration contains a directory of names and numbers. If the ICLID of an incoming call matches a number in the directory, the directory name is associated with that call and displayed on suitable receiving phones.

Applications such as SoftConsole also have directories that can be used for name matching. If a match occurs, it overrides the system directory name match for the name shown by that application.

#### Extended Length Name Display

In some locales, it may be desirable to change the way names are displayed on phones in order to maximize the space available for the called or calling name. There are two hidden controls which can be used to alter the way the system displays calling and called information.

These controls are activated by entering special strings on the Source Numbers tab of the NoUser user. These strings are:

**LONGER\_NAMES** This setting has the following effects:

- On DS phones, the call status display is moved to allow the called/calling name to occupy the complete upper line and if necessary wrap-over to the second line.
- For all phone types:

- On incoming calls, only the calling name is displayed. This applies even to calls forwarded from another user.
- On outgoing calls, only the called name is displayed.

**HIDE\_CALL\_STATE** This settings hides the display of the call state, for example **CONN** when a call is connected. This option is typically used in conjunction with **LONGER\_NAMES** above to provide additional space for name display.

---

## Parking Calls

Parking a call is an alternative to holding a call. A call parked on the system can be retrieved by any other user if they know the system park slot number used to park the call. When the call is retrieved, the action is known as Unpark Call or Ride Call. While parked, the caller hears music on hold if available.

Each parked call requires a park slot number. Attempting to park a call into a park slot that is already occupied causes an intercept tone to be played. Most park functions can be used either with or without a specified park slot number. When parking a call without specifying the park slot number, the system automatically assigns a number based on the extension number of the person parking the call plus an extra digit 0 to 9. For example if 220 parks a call, it is assigned the park slot number 2200, if they park another call while the first is still parked, the next parked call is given the park slot number 2201 and so on.

Park slot IDs can be up to 9 digits in length. Names can also be used for application park slots.

The **Park Timeout** setting in the system configuration (System | Telephony | Telephony | Park Timeout) controls how long a call can be left parked before it recalls to the user that parked it. The default time out is 5 minutes. Note that the recall only occurs if the user is idle has no other connected call.

There are several different methods by which calls can be parked and unparked. These are:

### Using Short Codes

The short code features, Call Park and Unpark Call, can be used to create short codes to park and unpark calls respectively. The default short codes that use these features are:

- \*37\*N# - Parks a call in park slot number N.
- \*38\*N# - Unparks the call in park slot number N.

### Using the SoftConsole Application

The SoftConsole application supports park buttons. SoftConsole provides 16 park slot buttons numbered 1 to 16 by default.

The park slot number for each button can be changed if required. Clicking on the buttons allows the user to park or unpark calls in the park slot associated with each button. In addition, when a call is parked in one of those slots by another user, the application user can see details of the call and can unpark it at their extension.

## Using Programmable Buttons

The Call Park feature can be used to park and unpark calls. If configured with a specified park slot number, the button can be used to park a call in that slot, unpark a call from that slot and will indicate when another user has parked a call in that slot. If configured without a number, it can be used to park up to 10 calls and to unpark any of those calls.

## Phone Defaults

Some telephones support facilities to park and unpark calls through their display menu options (refer to the appropriate telephone user guide). In this case parked calls are automatically put into park slots matching the extension number.

---

# Configuring Call Admission Control

Call Admission Control (CAC) is a method of controlling system resources using defined locations. Calls into and out of each location are allowed or disallowed based upon configured call constraints. In Manager, use the **Location** tab to define a location and configure the maximum calls allowed for the location.

## Related links

[Manager location tab](#) on page 615

[Assigning a network entity to a location](#) on page 616

[System actions at maximum call threshold](#) on page 616

[Example](#) on page 617

---

## Manager location tab

### Configuring location settings

On the Manager **Location** tab, set the following parameters for a location:

- Location Name
- Subnet Address
- Subnet Mask

### Configuring Call Admission Control settings

On the Manager Location tab, set the following CAC parameters:

- **Internal Maximum Calls:** Calls that pass from the location to another configured location.
- **External Maximum Calls:** Calls that pass from the location to an unmanaged location.
- **Total Maximum Calls:** The total internal and external calls permitted.

## Related links

[Configuring Call Admission Control](#) on page 615

---

## Assigning a network entity to a location

The **Location** field is a drop down list of locations defined on the **Location** tab. Network entities are assigned to a location using the **Location** field on the following Manager tabs.

- **System**
- **Extension**
- **SIP Line | VoIP**
- **H323 Line | VoIP**

The following default settings are applied.

- Each IP Office system can be configured with a defined location. For Server Edition deployments, the configuration of locations is done solution wide. All IP Office systems in the solution share the same location configuration.
- Digital phones default to the system location.
- The default setting for IP phones is **Automatic**. Phones registering from a subnet matching that of a location will be treated as within that location. Otherwise, the phone is assigned the same location as the system. Cloud can be used for phones whose Location is variable or unknown.
- IP Lines default to **Cloud**.

### Related links

[Configuring Call Admission Control](#) on page 615

---

## System actions at maximum call threshold

- A congestion alarm is raised.
- Calls that exceed the CAC maximum values are not allowed.
- Calls from extensions to public trunks through Alternate Route Selection (ARS) are queued and display **Waiting for Line**.
- Calls from extensions to public trunks which do not route through ARS receive a fast-busy tone and display **Congestion**.
- Idle phones display **Emergency/Local calls only**.
- Alternative routing to a local PSTN gateway follows ARS priority escalation rules.
- SIP calls that would exceed call limits and have no other targets are declined with **cause=486** or **cause = 503**.

### Allowed calls

When CAC limits have been reached, the following calls are allowed.

- Emergency calls are always allowed.



- Established calls are never torn down to achieve limits.
- A phone on a remote site that parks a call is always allowed to retrieve it.
- Request Coaching Intrusion calls are allowed.

**Related links**

[Configuring Call Admission Control](#) on page 615

---

**Example**

The example configuration has four locations.

Location	Max Calls
HQ	20
RS1	5
RS2	10
RS3	15
+Cloud	unlimited

SIP Line 10 and SIP Line 11 are configured with 20 channels.

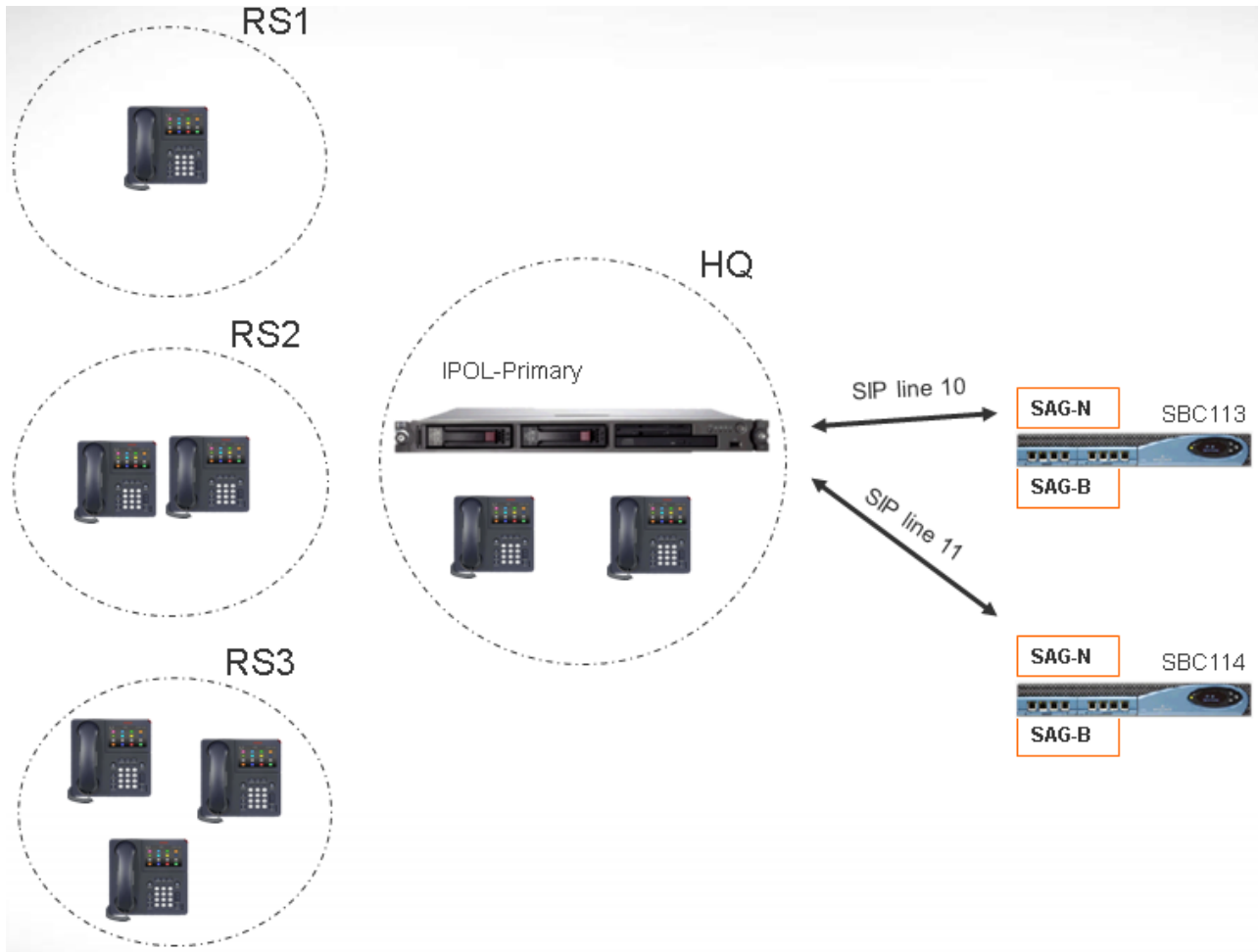

**Notes**

- Calls between locaton RS1 and SBC113 do not increment the call count for HQ.
- The HQ call count includes calls across the HQ boundary which anchor media inside HQ. SBC113 and SBC 114 are both included.
- The HQ maximum calls value is separate and complementary to the individual trunk call maximum.
- Incoming calls from SIP to RS1 (direct media) only need to verify that the RS1 location maximum call value is not exceeded.
- SIP calls that are not allowed to RS1 may go to HQ voicemail if the HQ call limit is not exceeded.

**Related links**

[Configuring Call Admission Control](#) on page 615

## Ring Tones

Ring tones can be defined in the following terms.

### Distinctive Ringing - Inside, Outside and Ringback:

A distinctive ring tone can be given for each of the different call types: an internal call, an external call and a ringback calls (voicemail calls, ringback when free calls, calls returning from park, hold or transfer).

The distinctive ringing patterns used for most non-analog phones are as follows:

- **Internal Call:** Repeated single-ring.
- **External Call:** Repeated double-ring.
- **Ringback Call:** Two short rings followed by a single ring.

### \* Note:

For non-analog extensions, the ringing pattern used for each call type by the system is not configurable.

### Personalized Ringing:

This term refers to control of the ringing sound through the individual phones. For non-analog phones, while the distinctive ringing patterns cannot be changed, the ringer sound and tone may be personalized depending on the phone's own options. Refer to the appropriate telephone user guide.

### Analog Phone Ringing Patterns

For analog extensions, the ringing pattern used for each call type can be set using the settings on **System | Telephony | Telephony**. The setting for an individual user associated with an analog extension can be configured using the settings on **User | Telephony | Call Settings**.

Note that changing the pattern for users associated with fax and modem device extensions may cause those devices to not recognize and answer calls.

The selectable ringing patterns are:

- **RingNormal** This pattern varies to match the **Locale** set in the **System | System** tab. This is the default for external calls.
- **RingType1:** 1s ring, 2s off, etc. This is the default for internal calls.
- **RingType2:** 0.25s ring, 0.25s off, 0.25s ring, 0.25s off, 0.25s ring, 1.75s off, etc. This is the default for ringback calls.
- **RingType3:** 0.4s ring, 0.8s off, ...
- **RingType4:** 2s ring, 4s off, ...
- **RingType5:** 2s ring, 2s off, ...
- **RingType6:** 0.945s ring, 4.5s off, ...
- **RingType7:** 0.25s ring, 0.24 off, 0.25 ring, 2.25 off, ...
- **RingType8:** 1s ring, 3s off, ...

- **RingType9**: 1s ring, 4s off, ...
- **RingType0**: Same as **RingNormal** for the United Kingdom locale.
- **Default Ring**: Shown on the User | Telephony | Call Setting tab. Indicates follow the settings on the System | Telephony | Tones & Music tab.

## Configuring Ring Tone Override for Groups and Incoming Call Routes

You can configure ring tone override for groups and incoming call routes. **Ring Tone Override** is supported on 1400 and 9500 series phones.

Note that you can use short codes to configure a ring tone plan by using the “r” character as part of the short code telephone number field. See [Short Code Characters](#) on page 808.

1. In Manager, select **System | Telephony | Ring Tones**.
2. In the **Ring Tone Plan** table, enter a **Name** for the ring tone. The **Number** field is populated automatically.
3. Under **Ring Tone**, select one of the eight ring tones from the drop down list.
4. Once configured in this table, ring tone names can be selected from the **Ring Tone Override** field at:
  - **Group | Group**
  - **Incoming Call Route | Standard**

---

## Music On Hold

Each system can provide music on hold (MOH) from either internally stored files or from externally connected audio inputs. Each system has one system source and then a number of alternate sources (up to 3 alternate sources on IP500 V2 and 31 alternate sources on Server Edition).

You must ensure that any MOH source you use complies with copyright, performing rights and other local and national legal requirements.

### WAV Files

The system can use internal files that it stores in its non permanent memory. The WAV file properties must be in the format listed below. If the file downloaded is in the incorrect format, it will be discarded from memory after the download.

- Mono PCM 8kHz 16-bit
- maximum length 90 seconds on IP500 V2 systems, 600 seconds on Linux based systems.
- The first WAV file, for the system source, must be called `HoldMusic.wav`. Alternate source WAV file names:
  - can be up to 27 IA5 characters
  - cannot contain spaces
  - any extension is allowed
  - case sensitive

The files, when specified by the system source or an alternate source setting, are loaded as follows:

- Following a reboot, the system will try using TFTP to download the file or files.
- The initial source for TFTP download is the system's configured **TFTP Server IP Address (System | System | LAN Settings)**. The default for this is a broadcast to the local subnet for any TFTP server.
- Manager can act as a TFTP server while it is running. If Manager is used as the TFTP server, then the wav file or files should be placed in the Manager applications working directory.

**\* Note:**

The following Manager settings are disabled by default:

- **Security Settings | Unsecured Interfaces | Applications Controls | TFTP Directory Read**
- **File | Preferences | Preferences | Enable BootP and TFTP Servers**
- On Linux based systems, if no successful TFTP download occurs, the system automatically looks for the files in the `opt/ipoffice/tones/mohwavdir` folder (`disk/tones/mohwavdir` when access using file manager).
- The name of the system music .wav file should be **HoldMusic.wav**. The name of alternate source .wav files should be as specified in the **Alternate Sources** table (**System | Telephony | Tones and Music**) minus the **WAV:** prefix.

#### WAV File Download and Storage:

- If no successful TFTP download occurs:
  - On IP500 V2 systems, the system automatically looks for the file in the `system/primary` folder on the System SD card and downloads it from if found.
  - On Linux based systems, the system automatically looks for the file in the folder `opt/ipoffice/system/primary` folder (`disk/system/primary` when accessed using file manager) and downloads it from there if found.
- If a music on hold file is downloaded, the system automatically write a copy of that file to its memory card, overwriting any existing file of the same name already stored on the card.
- For files downloaded from a System SD card, the system will download the file again if the SD card is shutdown and restarted or if files are uploaded to the card using the Embedded File Manager.
- The system will download the file again if new files are copied to the disk or uploaded using File Manager.

#### Tone

If no internal music on hold file is available and **External** is not selected as the **System Source**, then the system provides a default tone for music on hold. The tone used is double beep tone (425Hz repeated (0.2/0.2/0.2/3.4) seconds on/off cadence). **Tone** can be selected as the **System Source**, overriding both the use of the external source port and the downloading of **HoldMusic.wav**.

## Controlling the Music on Hold Source Used for Calls

Unless specified, the System Source is used for any calls put on hold by system users. For any call, the last source specified for the call is the one used. The following options allow the source to be changed.

- **Hunt Group** Each hunt group can specify a **Hold Music Source (Group | Group)**. That source is then used for calls presented to the hunt group.

In a multi system network, a hunt group member will hear the music on hold (MOH) from their local system. For example, a call comes in to site A and rings a hunt group with members from system A and system B. If a hunt group member from system B answers a call and puts the call on hold, the caller hears the MOH from system B.

- **Incoming Call Route** Each incoming call route can specify a **Hold Music Source (Incoming Call Route | Standard)**. That source is then used for incoming calls routed by that incoming call route.
- **Short Code** The **h** character can be used in the **Telephone Number** field of short codes to specify the hold music to associate with calls routed by that short code. The format **h( X )** is used where **X** is the source number. This method can be used to specify a hold music source for outgoing calls.

## Checking Music on Hold

The system short code feature Hold Music can be used to listen to the hold music sources. Dial **\*34N#**, replacing **N** with the source number 1 (System Source) or 2 to 32 (Alternate Sources).

### Related links

[System Source](#) on page 622

[Alternate Source](#) on page 622

---

## System Source

The first source is called the **System Source**. This source is numbered source 1. The possible options for this source are:

- **WAV**: A file called `HoldMusic.wav` downloaded by the system.
- **External**: For IP500 V2 systems, use the audio source connected to the back of the control unit. For Linux systems, the first available USB source is used.
- **Tone**: A double beep tone. Used automatically if the System Source is set to WAV and the **HoldMusic.wav** file has not been successfully downloaded.

### Related links

[Music On Hold](#) on page 620

---

## Alternate Source

You can specify alternate sources on the **System | Telephony | Tones and Music** page. The available options depends on the system type. For IP500 V2 systems, up to 3 alternate sources

can be specified. For systems on a Linux based server, up to 31 alternate sources can be specified. See the table below for details.

Alternate Option	Description
<b>WAV:&lt;filename&gt;</b>	<ul style="list-style-type: none"> <li>• The &lt;filename&gt; parameter specifies the filename to be played.</li> <li>• &lt;filename&gt;:               <ul style="list-style-type: none"> <li>- can be up to 27 IA5 characters</li> <li>- cannot contain spaces</li> <li>- any extension is allowed</li> <li>- case sensitive</li> </ul> </li> <li>• A TFTP read is attempted first, then the file location <code>opt/ipoffice/system/primary</code> (Linux) or <code>/system/primary</code> (IP500 V2).</li> <li>• When a MOH source is activated, the playback resumes from where it left off last time, instead of starting every time from the beginning.</li> <li>• At any moment, all users listening to a given MOH source will hear the same thing (instead of every user hearing from a different file position).</li> <li>• For Linux systems, this source is suitable for use with the <b>LINE</b> option.</li> </ul>
<b>XTN: &lt;extension&gt;</b>	<p>Only supported on IP500 V2 systems. Any analog extension with its Equipment Classification set as MOH Source can be entered as the alternate source. Enter XTN: followed by the extension's Base Extension number. For example <b>XTN:224</b></p>
<b>WAVRST:&lt;filename&gt;</b>	<ul style="list-style-type: none"> <li>• Not supported on IP500 V2 systems.</li> <li>• The &lt;filename&gt; parameter specifies the filename to be played.</li> <li>• A TFTP read is attempted first, then the folder <code>opt/ipoffice/system/primary</code> (SSH access) (<code>disk/system/primary</code> (file manager access)).</li> <li>• When a MOH source is activated, the playback is started every time from the beginning.</li> <li>• At any moment, all users listening to a given MOH source will hear a different WAV file or file position.</li> </ul>

*Table continues...*

Alternate Option	Description
<b>WAVDIR:</b>	<ul style="list-style-type: none"> <li>• Not supported on IP500 V2 systems.</li> <li>• No additional parameter is required.</li> <li>• The directory used is <code>opt/ipoffice/tones/mohwavdir</code> (SSH access) or <code>/disk/tones/mohwavdir</code> (file manager access).</li> <li>• Up to 255 files, up to 10 minutes per file.</li> <li>• The files are played in filename order (numerical, lower case, then upper case).</li> <li>• When a MOH source is activated, the playback resumes from where it left off last time.</li> <li>• At any moment, all users listening to this source will hear the same thing.</li> <li>• There can only be one WAVDIR: or WAVDIRRST: entry per system.</li> <li>• This is a streamed source suitable for use with the <b>LINE</b> option.</li> </ul>
<b>WAVDIRRST:</b>	<p>As per <b>WAVDIR</b> above, however</p> <ul style="list-style-type: none"> <li>• When a MOH source is activated, the playback is started every time from the beginning (start of the first file in the folder).</li> <li>• At any moment, all users listening to this source will hear a different WAV file or file position.</li> <li>• Not suitable for use with the <b>LINE</b> option.</li> </ul>

*Table continues...*



Alternate Option	Description
<b>USB: &lt;number&gt;</b>	<ul style="list-style-type: none"> <li>• Not supported on IP500 V2 systems.</li> <li>• The &lt;number&gt; parameter is the logical USB device number.</li> <li>• USB:1 is the first source found and is automatically used for the <b>System Source</b> when set to External.</li> <li>• Additional devices are numbered sequentially. For example, USB:2, USB:3. Up to four USB sources are supported.</li> <li>• IPOffice will auto-configure USB sound devices with settings that work well in most cases. Line input is selected and volume is set close to maximum. If no line input is identified on the card, microphone input is used instead.</li> <li>• Supported with ALSA USB sound cards, The following USB audio devices have been tested: <ul style="list-style-type: none"> <li>- Creative X-FI GO Pro USB</li> <li>- Asus Xonar U3</li> </ul> </li> <li>• External USB sound devices are hot-pluggable. They can be added and removed from the system at any time.</li> <li>• Care should be taken when adding or removing USB sound cards as this may change the logical number.</li> <li>• When an USB MOH source becomes unavailable, the default MOH tone will be played instead.</li> <li>• A USB MOH source is not supported on virtual servers.</li> <li>• This is a streamed source suitable for use with the <b>LINE</b> option.</li> </ul>

*Table continues...*

Alternate Option	Description
<p><b>LINE:&lt;X,Y&gt;</b></p>	<ul style="list-style-type: none"> <li>• Two parameters are supplied.                             <ul style="list-style-type: none"> <li>- X = SCN line number to the Linux Server (not outgoing group ID).</li> <li>- Y = The MOH source number on the Linux Server.</li> </ul> </li> <li>• The Linux Server is typically the Primary, but the Secondary Server can be used.</li> <li>• The MOH Source must be a stream type (Not WAVRST: or WAVDIRRST:)</li> <li>• Centralised MOH will place a VoIP call to the MOH source when MOH is required.</li> <li>• Takes one call capacity from the trunk and therefore, can be subject to CAC limits.</li> <li>• Uses the SCN trunks' codec preferences.</li> <li>• G.729 not recommended (better results are achieved with G.711).</li> <li>• Calls are dropped after 30s of no use.</li> <li>• If 30s is not appropriate, it can be changed with the NoUser source number HOLD_MUSIC_TIMEOUT=x, where x is number of seconds (range = 0 and 600). 0 means never tear down the call (and never retry – should not be used!)</li> <li>• The status displayed in SSA</li> <li>• Note that as this option can only be specified as an alternate source, centralized MOH cannot be used as the System Source. That is, it cannot be used for internal calls' MOH.</li> </ul>

**Related links**

[Music On Hold](#) on page 620

## Conferencing

The IP Office system supports a number of conference features and allows multiple simultaneous conferences.

### Conference Types

There are 2 types of conference supported by the system:

- **Ad-Hoc Conferencing** An ad-hoc conference is one created on the fly, typically by holding an existing call, making another call and then pressing a conference key on the phone. Other people can be added to the conference by repeating the process.
- **Meet Me Conferencing** Conference Meet Me allows users to join or start a specific numbered conference. This method of operation allows you to advertise a conference number and then let the other parties join the conference themselves.

**User Personal Conference Number** Each user's own extension number is treated as their own personal conference number. Only that user is able to start a conference using that number as the conference ID. Any one else attempting to start a conference with that number will find themselves in a conference but on hold until the owner also joins. Personal conferences are always hosted on the owner's system. Note, when a user calls from their mobile twinned number, the personal conference feature will only work if they access the conference using an FNE 18 service.

## Conference Notes

**Other Uses of Conference Resources** System features such as call intrusion, call recording and silent monitoring all use conference resources for their operation. On IP500 V2 systems, each Embedded Voicemail call in progress also reduces the conference capacity.

**Automatically Ending Conferences** The behavior for the system automatically ending a conference varies as follows:

- A conference remains active until the last extension or trunk with reliable disconnect leaves. Connections to voicemail or a trunk without reliable disconnect (for example an analog loop-start trunk) will not hold a conference open.
- The **Drop External Only Impromptu Conference** setting controls whether a conference is automatically ended when the last internal party exits the conference.

**Analog Trunk Restriction** In conferences that include external calls, only a maximum of two analog trunk calls are supported. This limit is not enforced by the system software.

**Recording Conferences** If call recording is supported, conference calls can be recorded just like normal calls. Note however that recording is automatically stopped when a new party joins the conference and must be restarted manually. This is to stop parties being added to a conference after any "advice of recording" message has been played.

**IP Trunks and Extensions** Conferencing is performed by services on the system's non-IP interface. Therefore a voice compression channel is required for each IP trunk or extension involved in the conference.

**Call Routing** A short code routing calls into a conference can be used as an Incoming Call Route destination.

**Conference Tones** The system provides conference tones. These will be either played when a party enters/leaves the conference or as a regularly repeated tone. This is controlled by the Conferencing Tone (**System | Telephony | Tones & Music**) option.

## Related links

- [Conference Phones](#) on page 627
- [Ad-Hoc Conferencing](#) on page 628
- [Meet Me Conferencing](#) on page 630
- [Routing External Callers](#) on page 631
- [Context Sensitive Conferencing](#) on page 632

---

## Conference Phones

The system does not restrict the type of phone that can be included in a conference call.

**Use Mute** When not speaking, use of the mute function helps prevent background noise from your location being added to the conference call. This is especially important if you are attempting to participate handsfree.

**Handsfree Participation** While many Avaya telephones can be used fully handsfree during a call, that mode of operation is intended only for a single user, seated directly in front of the phone. Attempting to use a handsfree phones for multiple people to listen to and participate in a call will rarely yield good results. See below for details of conference phones supported by the system.

#### Dedicated Conference Phones

To allow multiple people in one room to speak and listen to a conference call, the system supports the following conference phones:

- B100 Conference Phones (B179 and B199).
- Audio Conferencing Unit (ACU).

#### Group Listen

The **Group Listen** function can be used via a programmable button or short code. It allows the caller to be heard through a phones handsfree speaker while only being talked to via the phone's handset.

#### Related links

[Conferencing](#) on page 626

---

## Ad-Hoc Conferencing

Conference add controls can be used to place the user, their current call and any calls they have on hold into a conference. When used to start a new conference, the system automatically assigns a conference ID to the call. This is termed ad-hoc (impromptu) conferencing.

If the call on hold is an existing conference, the user and any current call are added to that conference. This can be used to add additional calls to an ad-hoc conference or to a meet-me conference. Conference add can be used to connect two parties together. After creating the conference, the user can drop from the conference and the two incoming calls remain connected.

#### Related links

[Conferencing](#) on page 626

## The methods below use the system's default system short codes

### About this task

#### Short Code

The Conference Add short code action is used to create short codes for ad-hoc conferencing. By default, the short code \*47 is added to new systems.

#### Starting an ad-hoc conference using a short code:

## Procedure

1. Place your current call on hold.
2. Call the party that you want to also include in the call.

## Result

- If answered and the other party wants to join the conference, put the call on hold and dial \*47.
- If not answered or diverted to voicemail or answered but the party does not want to join the conference, put the call on hold and dial \*52 to clear it.

You and the held calls are now in conference.

## Conference Button

### About this task

The Conference Add action can be assigned to a programmable button on phones that support programmable buttons. The button can then be used to start an ad-hoc conference or to add additional users to an existing conference.

On many Avaya phones, the same function is provided by a permanent Conference button. Alternatively the phone may display a Conf soft-key option during calls. Refer to the appropriate phone user guide.

### Starting an ad-hoc conference using a button or softkey:

## Procedure

1. With a current call connected, press the button.  
The current call is put on hold pending the conference.
2. Call the party that you want to also include in the call.

## Result

- If answered and the other party wants to join the conference, press the conference button again.
- If not answered or diverted to voicemail or answered but the party does not want to join the conference, end the call. Press the button representing the held call to reconnect to it.

You, the held call and the new call are now in a conference.

### Adding Calls to a Conference

You can use the same processes as above to add additional calls to a conference. While you hold a conference on your own telephone system, the existing members of the conference can still talk to each other.

---

## Meet Me Conferencing

Conference meet-me refers to features that allow a user or caller to join a specific conference by using the conference's ID number (either pre-set in the control or entered at the time of joining the conference).

IP500 V2 systems require a **Preferred Edition** license.

**\* Note:**

Conference Meet Me features can create conferences that include only one or two parties. These are still conferences that are using resources from the host system's conference capacity.

### Conference ID Numbers

By default, ad hoc conferences are assigned numbers starting from 100 for the first conference in progress. Therefore, for conference Meet Me features specify a number away from this range ensure that the conference joined is not an ad hoc conference started by other users. It is not possible to join a conference using conference Meet Me features when the conference ID is in use by an ad-hoc conference.

**User Personal Conference Number** Each user's own extension number is treated as their own personal conference number. Only that user is able to start a conference using that number as the conference ID. Any one else attempting to start a conference with that number will find themselves in a conference but on hold until the owner also joins. Personal conferences are always hosted on the owner's system.

**\* Note:**

When a user calls from their mobile twinned number, the personal conference feature will only work if they access the conference using an FNE 18 service.

### Multi-Site Network Conferencing

Meet Me conference IDs are now shared across a multi-site network. For example, if a conference with the ID 500 is started on one system, anyone else joining conference 500 on any system will join the same conference. Each conference still uses the conference resources of the system on which it was started and is limited by the available conference capacity of that system.

Previously separate conferences, each with the same conference ID, could be started on each system in a multi-site network.

### Other Features

**Transfer to a Conference Button** A currently connected caller can be transferred into the conference by pressing **TRANSFER**, then the Conference Meet Me button and **TRANSFER** again to complete the transfer. This allows the user to place callers into the conference specified by the button without being part of the conference call themselves. This option is only support on Avaya phones with a fixed **TRANSFER** button.

**Conference Button Status Indication** When the conference is active, any buttons associated with the conference ID indicate the active state.

## Short Codes

The Conference Meet Me short code action is used to create short codes for Meet Me conferencing. There are no default short codes in a new system for this type of function. It can also be used to transfer caller's into a Meet Me conference.

### Example 1: Specific Meet Me Conference Short Code

The following example system short code allows the dialing user to join a specific conference, in this meet-me conference 500.

**Short Code:** \*500

**Telephone Number:** 500

**Feature:** Conference Meet Me

### Example 2: General Meet Me Conference Short Code

The following example system short code allows any extension to dial \*67\* and then the number of the conference which they want to join followed by #. For example dialing \*67\*600# will put the user into meet-me conference 600.

**Short Code:** \*67\*N#

**Telephone Number:** N

**Feature:** Conference Meet Me

## Programmable Buttons

The Conference Meet Me action can be assigned to a programmable button on phones that support programmable buttons. The button can then be used to join a specified Meet Me conference. It can also be used to transfer caller's into a meet-me conference.

For buttons configured with a specific conference ID, the button will indicate whether a conference is in progress or not. For a button configured to a user's personal conference number, the button will indicate when other people are in the conference and when the owner is also in the conference.

### Related links

[Conferencing](#) on page 626

---

## Routing External Callers

Internal users can access Meet Me conferencing using short code and buttons. Additional methods need to be provided for external callers. Typically this is done using a system short code to which the external call is then directed by one of the options below. This has the advantage that internal users can also dial the same short code to access the same conferences.

### Transferring Callers

Conference Meet Me short codes and buttons can be used as the destination for call transfers by other users. If the short code or button is not configured with a specific conference ID, that value needs to be entered by the person transferring the call before completing the transfer.

### Incoming Call Routing

The method by which calls requiring access to a conference can be identified will depend on the customer requirement. However, once that is determined, a system short code configured for the specific conference required can be used as the destination for the appropriate incoming call route added to the system configuration.

If general access to more than one possible conference is required, Voicemail Pro is used. See below.

#### Voicemail Pro

Voicemail Pro call flows can include transfer actions. If the target is a short code for a specific conference, the call flow user is added to that conference. The use of a short code for this also allows internal users to access the same conference.

This option can be used with call flow features such as automatic attendants to provide access to more than one specific conference. For example, the call flow can prompt the caller to enter the ID of the conference they want to join. The call flow can then use the digits the caller dials as part of the short code to which the call is transferred.

#### Related links

[Conferencing](#) on page 626

## Context Sensitive Conferencing

On 1400, 1600, 9500 and 9600 Series telephones there have been changes to the display and handling of calls put on hold pending transfer. See Context Sensitive Transfer. For those phones there have also been changes to which calls are conferenced when a **Conference** button or **Conf** display option is pressed on the telephone.

Previously, pressing **Conference** would put the user's current call and all held calls into a conference. That included any calls that had been put on hold pending transfer by pressing **Transfer**. The result of pressing **Conference** on the telephone now depends on which call is currently highlighted on the phone display and what other calls are held or held pending transfer.

Which call is highlighted on the display	Other condition (in priority order)	Result when Conference is pressed:	Calls Conferenced		
			Connected Call	Held Calls	Held Pending Transfer
<b>Connected call</b>	<b>No call held pending transfer</b>	Conferences the connected call and all held calls.	✓	✓	–

*Table continues...*



	<b>Call held pending transfer</b>	Conferences the connected call and the held pending transfer call. Any other held calls are unaffected.	✓	–	✓
<b>Held call</b>	<b>Connected call</b>	Conferences the held call and the connected call. Any other held calls including held pending transfer are unaffected.	✓	–	–
	<b>Held pending transfer call</b>	Conferences the held and held pending transfer call. All other held calls are unaffected.	–	–	✓
	<b>Held calls</b>	Conferences with all other held calls.	–	✓	–
<b>Held pending transfer call</b>	<b>Connected call</b>	Conferences the held pending transfer call to a connected call. Any other held calls are unaffected.	✓	–	✓
	<b>Held calls</b>	Conferences the call held pending transfer with all other held calls.	–	✓	✓

Note that this new behaviour only applies to conferences being initiated from the telephone. The original behaviour of conferencing all calls still applies if the conference function is initiated from elsewhere such as from an application like one-X Portal.

**Changing which call is currently highlighted** On phones with a set of cursor keys (four cursor keys around an **OK** key), the up and down cursor key can be used to change the current highlighted call (or call appearance if idle). This can be done even whilst there is a currently

connected call. On touchscreen phones, the cursor buttons on the right-hand edge of the screen can be used for the same purpose. The method of highlighting is

- **1400 Series/1600 Series Telephones** On these phones only details of a single call are shown on the display at any time. The displayed call is the currently highlighted call.
- **9500 Series/9600 Series Telephones** On most phones in these series, the background of the shading is changed for the currently selected call. The exceptions are 9611, 9621, 9641, J159 and J179 telephones where a yellow symbol is shown on the right of the highlighted call.

**Related links**

[Conferencing](#) on page 626

## Paging

### Paging limits

Server Type	Paging Group Maximum size (Select and Non-Select)
Dell R620	512
Dell R630	512
Dell R640	512
OVA	512
DL360G7	128
HP120G7/Dell R210 II	128
IP500 V2	64

- Paging groups that include users on a V2 Expansion are limited to 64 members.
- Paging groups that include SRTP endpoints, the maximum size is reduce by 50%.

### Paging Scenarios

Paging Scenario	Paged Device Connects to...	Short Code/ Button Feature
Phone to Phone: Simple paging to other system extensions.	Digital Station and Avaya H.323 Phones	<b>Dial Paging</b>
Mixed Paging: Simultaneous paging to phones and a paging speaker.	Analog Extension (Paging Speaker)	<b>Dial Paging</b>
Paging Interface Device: Paging to a paging interface device such as a UPAM.	Analog Extension (IVR Port)	<b>Dial Extn</b>
	Analog Trunk	<b>Dial</b>

## Phone to Phone Paging

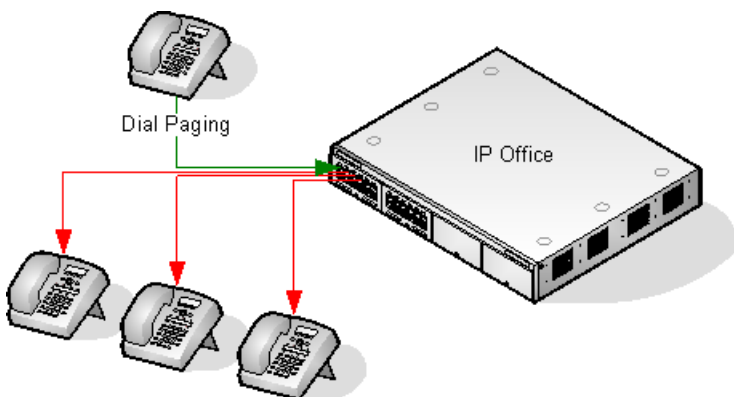

- Paging is supported from all phone types. A page call can be to a single phone or a group of phones.
  - From analog and non-Avaya phones, use a Dial Paging short code.
  - From Avaya feature phones, a programmable button set to Dial Paging can be used.
- Paging is only supported to Avaya phones that support auto answer.
- The page is not heard on phones that are active on another call.
- The page is not heard on phones where the user is set to Do Not Disturb or has Forward Unconditional active.
- On Avaya phones with a dedicated **Conference** button, the user can answer a page call by pressing that button. This turns the page into a normal call with the pager.

## Mixed Paging

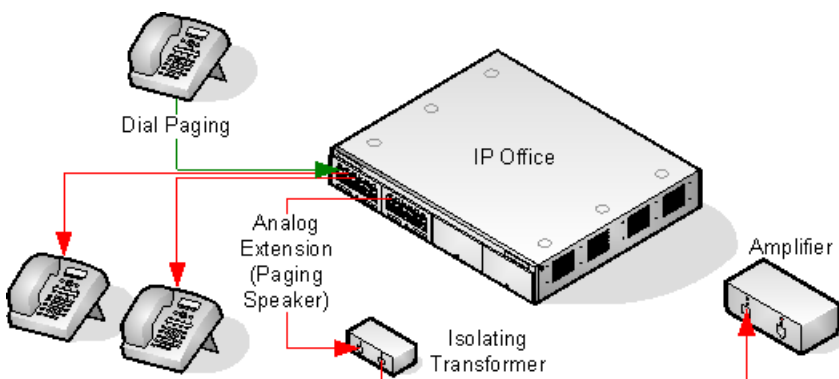

Uses an amplifier connected to an analog extension port via a 600ohm isolating transformer. Some amplifiers include an integral transformer. Avaya/Lucent branded amplifiers are designed for connection to special paging output ports not provided on systems. They are not suitable for supporting mixed paging.

The transformer and amplifier must be connected when the system is restarted.

If background music is required between pages, the amplifier must support a separate background music connection and VOX switching.

The analog extension port is set as a Paging Speaker in the system configuration (**Extn | Analog | Equipment Classification**).

Short code/programmable button: Use DialPaging.

### Paging Interface Device

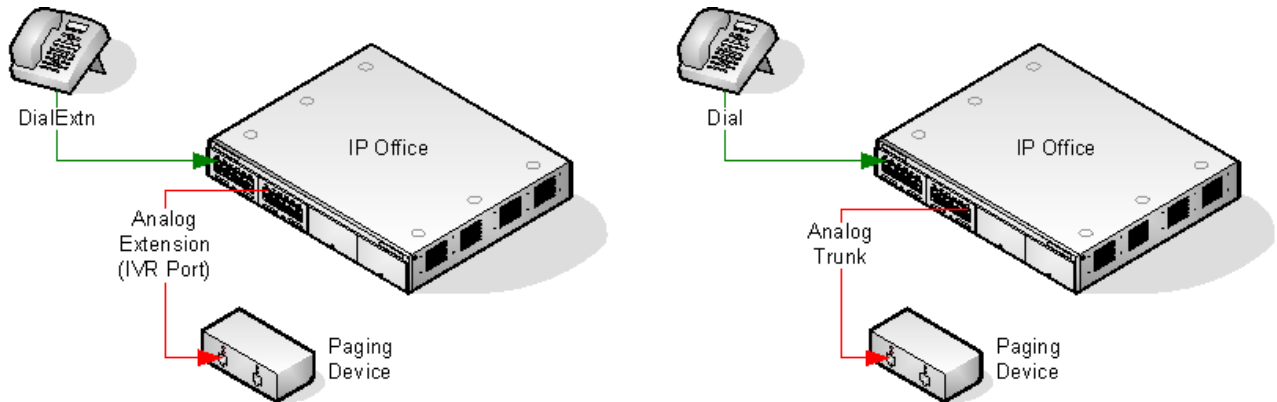

Uses a paging interface device such as a UPAM or amplifier with analog trunk/extension interface. The device can be connected to an analog trunk port or analog extension port.

If connected to a trunk port, use the short code Use Dial and the same Line Group ID as the Outgoing Line ID set for the analog trunk.

If connected to an extension port:

- Set the analog extension as an IVR Port in the system configuration (Extn | Analog | Equipment Classification).
- Short code/programmable button: Use Dial Extn.

#### Related links

[Paging Via Voicemail Pro](#) on page 636

---

## Paging Via Voicemail Pro

Voicemail Pro can be used to deliver pre-recorded announcements. This can be useful when the same announcement is repeated frequently. This method requires the paging port to be an analog extension.

This method also removes the feedback loop that can occur on some sites as the page is first recorded and then played.

#### Example 1

1. In Voicemail Pro, a new Module was added and named Page.

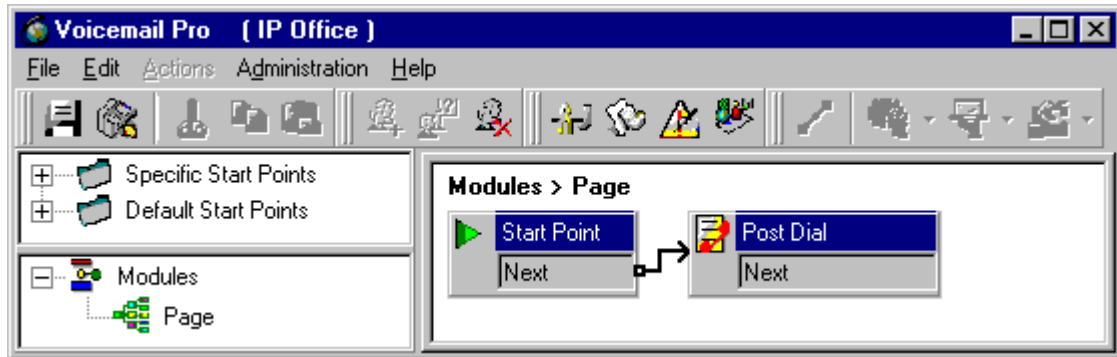

2. A Post Dial action was added to the module. The properties of the Specific tab were set as shown:

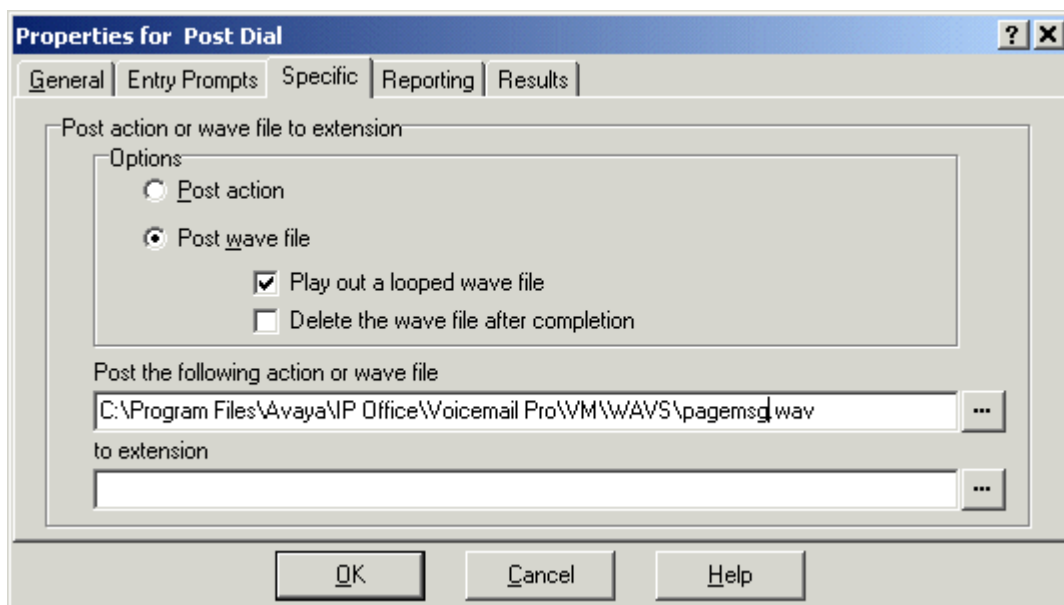

3. We then saved and made live the new Voicemail Pro call flow.
4. In Manager we received the system configuration and created a new short code.
  - Short Code: \*80
  - Telephone Number : "Page"
  - Feature: VoicemailCollect.

The new system configuration was then merged.

#### Example 2

This example builds on example 1 by allowing the user to select which message is played from a menu. In this example the user can press 1, 2 or 3 for different messages. They can also re-record the message associated with option 3 by pressing #.

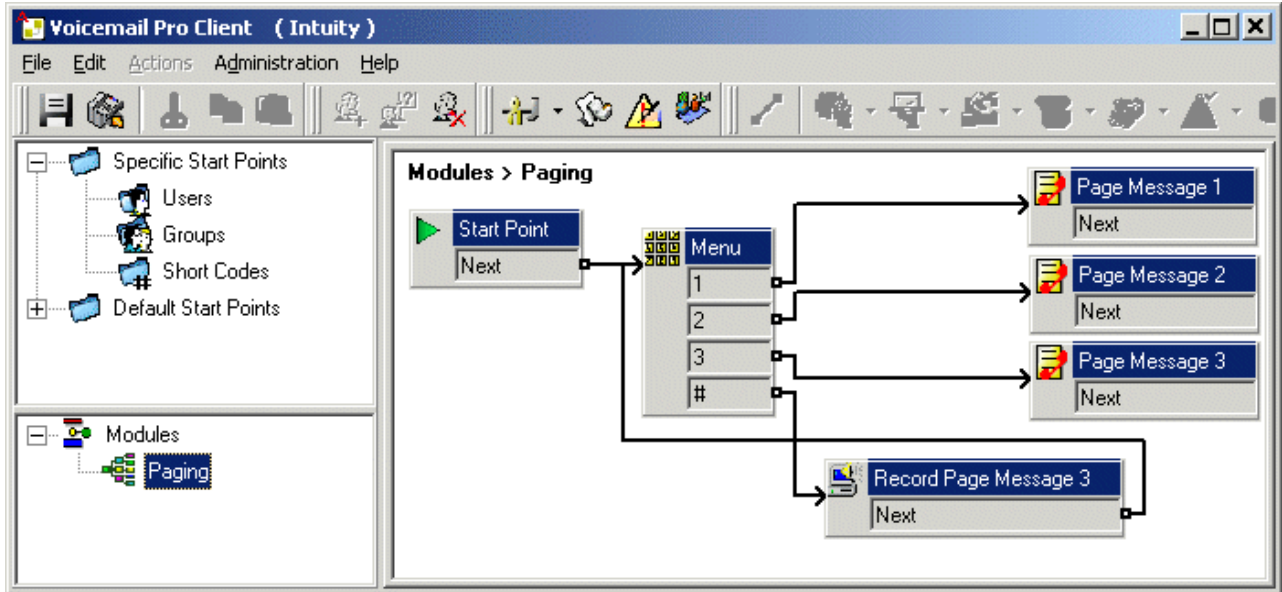

A Play List action was added and in this example set to record pagemsg3.wav. Note that just the file name was specified as this action saves files relative to the Voicemail Server's WAVS folder.

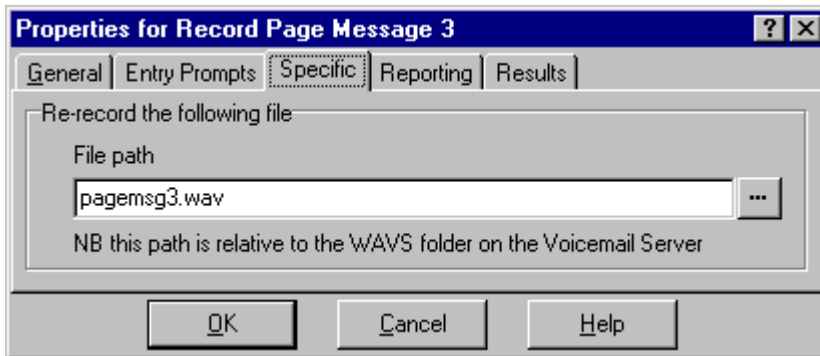

In the Post Dial action that plays back pagemsg3.wav note that the full file path needs to be used.

In Manager, we then added a short code that triggers the module "Paging" using the VoicemailCollect feature.

### Related links

[Paging](#) on page 634

---

## Automatic Intercom Calls

Automatic intercom functions allow you to call an extension and have the call automatically answered on speaker phone after 3 beeps. The extension called must support a handsfree speaker. If the extension does not have a handsfree microphone then the user must use the

handset if they want to talk. If the extension is not free when called, the call is presented as a normal call on a call appearance button if available.

### Making Automatic Intercom Calls

The following programmable button functions can be used to make automatic intercom calls:

- **Automatic Intercom**
- **Dial Direct**
- **Dial Intercom**

The following short code function can be used to make automatic intercom calls:

#### Dial Direct

On M-Series and T-Series phones, the code **Feature 66** followed by the extension number can be used to make a direct voice (automatic intercom) call.

#### Deny automatic intercom calls

When enabled, any automatic intercom calls to the user's extension are automatically turned into normal calls.

Deny automatic intercom calls can be configured per user on the **User | Telephony | Supervisor Settings** tab. Deny automatic intercom call can also be enabled using the Auto Intercom Deny On short code or the Auto Intercom Deny button action.

## Wide Band Audio Support

IP Office systems support the G.722 64K codec for wide band audio. G.722 can be used with H.323 and SIP trunks. It can also be used with some SIP and H.323 IP telephones (see below). G.722 uses a higher speech sample rate (16KHz) than is used by most other audio codecs (8KHz).

G.722 is only supported by systems that are using IP500 VCM, IP500 VCM V2 and or IP500 Combination cards.

### Avaya Phone Support

Use of G.722 is supported by the following Avaya phones on a IP Office system:

B179	1140E	9621	9650
1010	9608	9630	J129
1040	9611	9640	J139
1120E	9620	9641	J159
J169	J179	J189	B199

### Using the G.722 Codec

The G.722 codec is not available for use by default. If the codec is to be used, it must first be selected in the system's **Available Codecs** list (System | Codecs). The codec can then be used in

the system's default codec preference list and or in the individual codec preferences of IP lines and extensions.

The method of codec selection for specific phones will depend on the phone type. Refer to the appropriate installation manual.

### **Conferencing**

Where devices using G.722 are in a system conference, the system can attempt to ensure that the speech between devices using G.722 remains wide-band even if there are also narrow-band audio devices in the same conference. This is done if the system's High Quality Conferencing option is enabled (**System | Telephony | Telephony**).

### **Known Limitations**

The following limitations apply to G.722 wide band audio operation:

- Call recording uses G.711.
- Page calls only use G.722 when all devices being paged can use G.722.
- Fax is not supported in G.722, use G.711 or T38.
- Soft tones provided by the system use G.711.
- A maximum of 15 G.722 devices receiving wide-band audio are supported in conferences.

---

## **Media Connection Preservation**

Media Connection Preservation maintains calls that experience end-to-end signalling loss or refresh failures but that still have an active media path.

### **IP Phones:**

With IP Office 9.1 and higher, the following Avaya IP phones attempt to maintain calls when the signal from the host IP Office is lost.

- 9608
- 9611
- 9621
- 9641
- J100 Series

When preserving a call, the phone does not attempt to reregister with their call server or attempt to failover to a standby call server, until the call has ended. Softkey call actions and feature menus do not work during this time due to the loss of signalling path. The phone display is not updated and the only permitted action is to terminate the call.

### **IP Office:**

When enabled for a particular IP endpoint type that supports Media Connection Preservation, the call is put into a Preserved state and a Preservation Interval timer is started for that call at the point the signalling loss is detected. The maximum duration of a preserved call on IP Office is two



hours. Once put into the Preserved state, a call can only transition to the Terminated state. Call restoration is not supported.

Only the following call types are preserved:

- Connected active calls
- Two party calls where the other end is a phone, trunk, or voicemail
- Conference calls
- Calls on hold and calls to hunt groups are not preserved.

### **Phone Display:**

When a call is in a preserved state but the phone's local signalling connection with its host IP Office is still present, the phone call state display is prefixed with a warning icon. Hold, transfer, and conference actions are not available.

### **System Configuration**

When enabled on **System | Telephony | Telephony**, Media Connection Preservation is applied at a system level to SCN trunks and Avaya H.323 phones that support connection preservation. All systems in a Small Community Network (SCN) must be enabled for end to end connection preservation to be supported.

When enabled on **Line | SIP Line | SIP Advanced**, Media Connection Preservation is applied to the SIP trunk. The value of connection preservation on public SIP trunks is limited. Media Connection Preservation on public SIP trunks is not supported until tested with a specific service provider. Media Connection Preservation is disabled by default for SIP trunks.

When enabled on **Line | SM Line | Session Manager**, Media Connection Preservation is applied to Enterprise Branch deployments. Media Connection Preservation preserves only the media and not the call signaling on the SM Line. Media Connection Preservation does not include support for the Avaya Aura Session Manager Call Preservation feature.

---

## **Configuring ARS**

When a dialed number matches a short code that specifies that the number should be dialled, there are two methods by which the routing of the outgoing call can be controlled.

### **Routing Calls Directly to a Line:**

Every line and channel has an Outgoing Group ID setting. Several lines and channels can have belong to the same Outgoing Group ID. Within short codes that should be routed via a line within that group, the required Outgoing Group ID is specified in the short code's Line Group ID setting.

### **Routing Calls via ARS:**

The short code for a number can specify an ARS form as the destination. The final routing of the call is then controlled by the setting available within that ARS form.

### **ARS Features**

#### **Secondary Dial Tone:**

The first ARS form to which a call is routed can specify whether the caller should receive secondary dial tone.

**Out of Service Routing:**

ARS forms can be taken out of service, rerouting any calls to an alternate ARS form while out of service. This can be done through the configuration or using short codes.

**Out of Hours Routing:**

ARS forms can reroute calls to an alternate ARS form outside the hours defined by an associated time profile.

**Priority Routing:**

Alternate routes can be made available to users with sufficient priority if the initial routes specified in an ARS form are not available. For users with insufficient priority, a delay is applied before the alternate routes become available.

**Line Types:**

ARS can be used with all line types.

A SIP line is treated as busy and can follow alternate routes based on the SIP line setting **Call Initiation Timeout**. Previously a SIP line was only seen as busy if all the configured channels were in use.

IP lines use the NoUser Source Number setting **H.323SetupTimerNoLCR** to determine how long to wait for successful connection before treating the line as busy and following ARS alternate routing. This is set through the IP line option **Call Initiation Timeout**.

**Multi-Site Network Calls:**

Calls to multi-site extension numbers are always routed using the appropriate network trunk. ARS can be configured for multi-site network numbers but will only be used if the network call fails due to congestion or network failure.

**Main Route:**

The ARS form 50, named "Main" cannot be deleted. For defaulted systems it is used as a default route for outgoing calls.

**Routing Calls to ARS**

1. Create the ARS form.
2. Create the required system, user or user rights short code to match the user dialing.
  - a. In the **Telephone Number** field, define the digits that will be used to match a short code in the ARS form.
  - b. Use the **Line Group ID** field drop-down to select the ARS form required for routing the call.

**Related links**

[Example ARS Operation](#) on page 643

[ARS Operation](#) on page 644

## Example ARS Operation

The simplest example for ARS operation are the settings applied to a defaulted system. These vary between U-Law systems and A-Law systems. For Server Edition systems refer to Server Edition Outgoing Call Routing.

### A-Law Systems

This set of defaults is applied to A-Law systems, typically supplied to locales other than North America. The defaults allow any dialing that does not match an internal number to be routed off-switch as follows:

#### System Short Code - `?/Dial/.50:Main:`

The default system short code `?` will match any dialing for which no other user, user rights or system short code match is found. This short code is set to route all the digits dialed to ARS form 50.

#### ARS Form - `50:Main:`

This form contains just a single short code.

`?/Dial3K1/.0` This short code matches any digits passed to the ARS form. It then dials the digits out on the first available line within line group 0 (the default outgoing line group for all lines).

### U-Law Systems

This set of defaults is applied to U-Law systems, typically supplied to locales in North America. The defaults route any dialing prefixed with a 9 to the ARS and secondary dial tone.

#### System Short Code - `9N/Dial/N/50:Main:`

The default system short code `9N` is used to match any dialing that is prefixed with a 9. It passes any digits following the 9 to ARS form 50.

#### ARS Form - `50:Main:`

This form has secondary dial tone enabled. It contains a number of short codes which all pass any matching calls to the first available line within line group 0 (the default outgoing line group for all lines). Whilst all these short code route calls to the same destination, having them as separate items allows customization if required. The short codes are:

- **`11/Dial Emergency/911/0`** This short code matches an user dialing 911 for emergency services.
- **`911/Dial Emergency/911/0`** This short code matches an user dialing 9911 for emergency services.
- **`0N;/Dial3K1/0N/0`** This short code matches any international calls.
- **`1N;/Dial3K1/1N/0`** This short code matches any national calls.
- **`XN;/Dial3K1/N/0`** This short code matches 7 digit local numbers.
- **`XXXXXXXXXX/Dial3K1/N/0`** This short code matches 10 digit local numbers.

### Related links

[Configuring ARS](#) on page 641

## ARS Operation

The diagram below illustrates the default ARS routing applied to systems (other than Server Edition) defaulted to the **United States** system locale. In summary:

- Any dialing prefixed with 9 will match the default system short code **9N**.
- That short code routes calls to the default ARS form **50:Main**.
- The short codes in that ARS form route all calls to an available line that has its **Outgoing Group ID** set to **0**.

The screenshot shows two configuration windows. The left window is titled 'Short Code' and has a large '9x' icon. It contains the following fields:

- Code: 9N
- Feature: Dial
- Telephone Number: N
- Line Group Id: 50: Main
- Locale: (empty)
- Force Account Code:

The right window is titled 'ARS' and has a bird icon. It contains the following fields:

- ARS Route Id: 50
- Route Name: Main
- Dial Delay Time: System Default (4)
- In Service:  (with arrows pointing to Out of Service Route: <None>)
- Time Profile: <None> (with arrows pointing to Out of Hours Route: <None>)
- Secondary Dial tone:  (with dropdown: SystemTone)
- Check User Call Barring:

Below these fields is a table with columns: Code, Telephone Number, Feature, Line Group Id, and buttons: Add..., Remove, Edit...

Code	Telephone Number	Feature	Line Group Id
11	911	Dial Emergency	0
911	911	Dial Emergency	0
0N;	0N	Dial 3K1	0
1N;	1N	Dial 3K1	0
XN;	N	Dial 3K1	0
XXXXXXXXXXN	N	Dial 3K1	0

Below the table are fields for:

- Alternate Route Priority Level: 3 (with arrow pointing to Additional Route: <None>)
- Alternate Route Wait Time: 30 (with arrow pointing to Additional Route: <None>)

The table describes in more detail the process that the system has applied to the user's dialing, in this example 91555707392200.

The user dials...

*Table continues...*

9	<p>The <b>Dial Delay Count</b> is zero, so the system begins looking for short code matches in the system and user's short codes immediately.</p> <p>Since there is only one match, the <b>9N</b> system short code, it is used immediately.</p> <p>The <b>9N</b> short code is set to route the call to the ARS form <b>Main</b>. It only passes those digits that match the N part of the dialing, ie. the 9 is not passed to the ARS, only any further digits dialed by the user.</p> <p><b>Secondary Dial Tone</b> is selected in the ARS form. Since no digits for ARS short code matching have been received, secondary dial tone is played to the user.</p>
1	<p>Having received some digits, the secondary dial tone stops.</p> <p>The ARS form short codes are assessed for matches.</p> <p>The <b>11</b> and <b>1N</b>; short codes are possible matches.</p> <p>The <b>911</b> and <b>0N</b>; short codes are not possible matches.</p> <p>The <b>XN</b>; and <b>XXXXXXXXXXN</b>; short codes are also not matches because the <b>1N</b>; short code is already a more exact match.</p> <p>Since there is more than one possible match, the system waits for further digits to be dialed.</p>
555	<p>The <b>11</b> short code is no longer a possible match. The only match is left is the <b>1N</b>; short code.</p> <p>The ; in the short code tells the system to wait for the <b>Dial Delay Time</b> to expire after the last digit it received before assuming that dialing has been completed. This is necessary for line providers that expect to receive all the routing digits for a call 'en bloc'. The user can also indicate they have completed dialing by pressing #.</p>
707392200	<p>When the dialing is completed, a line that has its <b>Outgoing Group ID</b> set to 0 (the default for any line) is seized.</p> <p>If no line is available, the alternate route settings would applied if they had been configured.</p>

### Related links

[Configuring ARS](#) on page 641

[ARS Short Codes](#) on page 646

[Simple Alternate Line Example](#) on page 647

- [Simple Call Barring](#) on page 648
- [User Priority Escalation](#) on page 648
- [Time Based Routing](#) on page 649
- [Account Code Restriction](#) on page 650
- [Tiered ARS Forms](#) on page 651
- [Planning ARS](#) on page 652

## ARS Short Codes

The short codes in the default ARS form have the following roles:

Code	Feature	Telephone Number	Line Group ID	Description
<b>11</b>	<b>Dial Emergency</b>	<b>911</b>	<b>0</b>	These two short codes are used to route emergency calls. A <b>Dial Emergency</b> call is never blocked. If the required line is not available, the system will use the first available line. Similarly, calls using <b>Dial Emergency</b> ignore any outgoing call bar settings that would be normally applied to the user.
<b>911</b>	<b>Dial Emergency</b>	<b>911</b>	<b>0</b>	
<b>0N;</b>	<b>Dial 3K1</b>	<b>0N</b>	<b>0</b>	Matches international numbers.
<b>1N;</b>	<b>Dial 3K1</b>	<b>1N</b>	<b>0</b>	Matches national numbers.
<b>XN;</b>	<b>Dial 3K1</b>	<b>N</b>	<b>0</b>	Matches 7 digit local numbers.
<b>XXXXXXXXXXN;</b>	<b>Dial 3K1</b>	<b>N</b>	<b>0</b>	Matches 10 digit local numbers.

### ARS Short Code Settings

**Code** The digits used for matching to the user dialing.

**Feature** ARS short codes can use any of the **Dial** short code features or the **Barred** feature. When a **Barred** short code is matched, the call will not proceed any further.

**Telephone Number** The number that will be output to the line as the result of the short code being used as the match for the user dialing. Short code characters can be used such as N to match any digits dialed for N or X in the **Code**.

**Line Group ID** The line group from which a line should be seized once short code matching is completed. Another ARS form can also be specified as the destination.

**Locale** Not used for outgoing external calls.

**Forced Account Code** If enabled, the user will be prompted to enter a valid account code before the call can continue. The account code must match one set in the system configuration.

**Related links**

[ARS Operation](#) on page 644

**Simple Alternate Line Example**

Using the default ARS settings, despite having several short codes in the ARS form, all outgoing calls are actually routed the same way using the same trunks. However, by having separate short codes for different call types present, it is easy to change the routing of each call type if required.

For this example, the customer has separate sets of lines for local calls and for national/international calls. These have been configured as follows:

- The lines for local and emergency calls have been left with the default **Outgoing Group ID** of **0**.
- The lines for national and international calls have been set with the **Outgoing Group ID** of **1**.

The default ARS can be configured to match this by just changing the **Line Group ID** settings of the default ARS short codes to match.

The screenshot shows the configuration interface for an ARS (Alternate Route Selection) system. It is divided into three main sections:

- Short Code (9x):**
  - Code: 9N
  - Feature: Dial
  - Telephone Number: N
  - Line Group Id: 50: Main
  - Locale: (empty)
  - Force Account Code:
- ARS (K):**
  - ARS Route Id: 50
  - Route Name: Main
  - Dial Delay Time: System Default (4)
  - In Service:  (Out of Service Route: <None>)
  - Time Profile: <None> (Out of Hours Route: <None>)
  - Secondary Dial tone:  SystemTone
  - Check User Call Barring:
  - Table of Short Codes:

Code	Telephone Number	Feature	Line Group Id
11	911	Dial Emergency	0
911	911	Dial Emergency	0
0N;	0N	Dial 3K1	1
1N;	1N	Dial 3K1	1
XN;	N	Dial 3K1	0
XXXXXXXXXXN	N	Dial 3K1	0
- Line Settings (T):**
  - Line Number: 5
  - Card/Module: 2
  - Port: 9
  - Telephone Number: (empty)
  - Incoming Group ID: 0
  - Outgoing Group ID: 1
  - Outgoing channels: 1
  - Voice channels: 1

Blue arrows indicate the configuration flow: from Short Code settings to ARS settings, and from ARS settings to Line Settings. Specifically, the 'Line Group Id' in the Short Code section is linked to the 'Line Group Id' column in the ARS table, and the 'Outgoing Group ID' in the Line Settings section is linked to the 'Line Group Id' values in the ARS table.

**Related links**

[ARS Operation](#) on page 644

**Simple Call Barring**

All ARS short codes use one of the **Dial** short code features. The exception is the **Barred** short code feature. This can be selected for ARS short codes that match dialing that is not allowed.

In the example below, any user dialing an international number will be routed to the **Barred** short code. This prevents the dialing of external numbers prefixed with 0.

The screenshot displays the configuration for an ARS (Automatic Route Selection) system. It shows two windows: one for a 'Dial' short code (9N) and another for a 'Barred' short code (0N;). The 'Barred' short code is linked to Line Group Id 0. A table below lists various short codes and their features. The 'Barred' short code (0N;) is highlighted. Other settings include ARS Route Id (50), Route Name (Main), and Alternate Route Priority Level (3).

Code	Telephone Number	Feature	Line Group Id
11	911	Dial Emergency	0
911	911	Dial Emergency	0
0N;	0N	Barred	0
1N;	1N	Dial 3K1	0
XN;	N	Dial 3K1	0
XXXXXXXXXXN	N	Dial 3K1	0

To restrict a user from making any outgoing external calls, use the user's Outgoing Call Bar option.

**Related links**

[ARS Operation](#) on page 644

**User Priority Escalation**

User priority can be used to alter call routing when the required route is not available.

In this example, international calls are initially targeted to seize a line in outgoing line group 1. However an alternate route has been defined which will be used if no line in line group 1 is available. The fallback ARS form allows international calls to seize a line from line group 0. Whether this is done immediately or after a delay is set by whether the users priority is high enough.



**Short Code Configuration:**

- Code: 9N
- Feature: Dial
- Telephone Number: N
- Line Group Id: 50: Main
- Locale: [Dropdown]
- Force Account Code:

**User Configuration:**

- Name: Extn201
- Full Name: Extn201
- Extension: 201
- Priority: 5
- Ex Directory:

**ARS 50 Configuration:**

- ARS Route Id: 50
- Route Name: Main
- Dial Delay Time: System Default (4)
- In Service:
- Time Profile: <None>
- Secondary Dial tone:  SystemTone
- Check User Call Barring:

Code	Telephone Number	Feature	Line Group Id
11	911	Dial Emergency	0
911	911	Dial Emergency	0
0N;	0N	Dial 3K1	1
1N;	1N	Dial 3K1	1
XN;	N	Dial 3K1	0
XXXXXXXXXXN	N	Dial 3K1	0

**ARS 51 Configuration (Fallback):**

- ARS Route Id: 51
- Route Name: Fallback
- Dial Delay Time: System Default (4)
- In Service:
- Time Profile: <None>
- Secondary Dial tone:  SystemTone
- Check User Call Barring:

Code	Telephone Number	Feature	Line Group Id
11	911	Dial Emergency	0
911	911	Dial Emergency	0
0N;	0N	Dial 3K1	0
1N;	1N	Dial 3K1	1
XN;	N	Dial 3K1	0
XXXXXXXXXXN	N	Dial 3K1	0

**Related links**

[ARS Operation](#) on page 644

**Time Based Routing**

Time profiles can be used to switch call routing from one ARS form to another.

In the example below, a time profile has been define that sets the hours for normal operation. Outside the times set in the time profile, the other ARS form is used. This other ARS form only allows local and emergency calls.

## Configure General System Settings

The screenshot displays the configuration interface for Avaya Manager, divided into three main sections: Short Code, Time Profile, and ARS (Automatic Route Selection).

**Short Code Configuration:**

- Short Code: 9x
- Code: 9N
- Feature: Dial
- Telephone Number: N
- Line Group Id: 50: Main
- Locale: [Dropdown]
- Force Account Code:

**Time Profile Configuration:**

- Name: Office Hours
- Time Entry List:

Start Time	End Time	Recurrence
07:30	19:00	Monday To Friday

**ARS Configuration (Top):**

- ARS Route Id: 50
- Route Name: Main
- Dial Delay Time: System Default (4)
- In Service:  → Out of Service Route: <None>
- Time Profile: Office Hours → Out of Hours Route: Closed
- Secondary Dial tone: SystemTone
- Check User Call Barring:
- Table:

Code	Telephone Number	Feature	Line Group Id
11	911	Dial Emergency	0
911	911	Dial Emergency	0
0N;	0N	Dial 3K1	0
1N;	1N	Dial 3K1	0
XN;	N	Dial 3K1	0
XXXXXXXXXXN	N	Dial 3K1	0
- Alternate Route Priority Level: 3
- Alternate Route Wait Time: 30 → Additional Route: <None>

**ARS Configuration (Bottom):**

- ARS Route Id: 52
- Route Name: Closed
- Dial Delay Time: System Default (4)
- In Service:  → Out of Service Route: <None>
- Time Profile: Office Closed → Out of Hours Route: <None>
- Secondary Dial tone: SystemTone
- Check User Call Barring:
- Table:

Code	Telephone Number	Feature	Line Group Id
11	911	Dial Emergency	0
911	911	Dial Emergency	0
0N;	0N	Barred	0
1N;	1N	Barred	0
XN;	N	Dial 3K1	0
XXXXXXXXXXN	N	Dial 3K1	0
- Alternate Route Priority Level: 3
- Alternate Route Wait Time: 30 → Additional Route: <None>

### Related links

[ARS Operation](#) on page 644

## Account Code Restriction

The short codes within an ARS form can be individually set to require an account code before allowing any call that matches it to proceed.

In the example below, the short code for international calls has been set to require the user to enter an account code. A valid account code must be dialed to continue with the call.

The screenshot displays the configuration interface for an ARS (Automatic Route Selection) form. It is divided into two main sections: 'Short Code' and 'ARS'.

**Short Code Configuration:**

- Code: 9N
- Feature: Dial
- Telephone Number: N
- Line Group Id: 50: Main
- Locale: (empty)
- Force Account Code:

**ARS Configuration:**

- ARS Route Id: 50
- Route Name: Main
- Dial Delay Time: System Default (4)
- In Service:  (Out of Service Route: <None>)
- Time Profile: <None> (Out of Hours Route: <None>)
- Secondary Dial tone:  SystemTone
- Check User Call Barring:

**Short Code Table:**

Code	Telephone Number	Feature	Line Group Id
11	911	Dial Emergency	0
911	911	Dial Emergency	0
0N;	0N	Dial 3K1	0
1N;	1N	Dial 3K1	0
XN;	N	Dial 3K1	0
XXXXXXXXXXN	N	Dial 3K1	0

**ARS Additional Settings:**

- Alternate Route Priority Level: 3
- Alternate Route Wait Time: 30
- Alternate Route: <None>

If a user should always enter an account code to make any external call, the user option Force Account Code should be used.

**Related links**

[ARS Operation](#) on page 644

**Tiered ARS Forms**

It is possible for an ARS short code in one form to have another ARS form as its destination. Dialing that matches the short code is then subject to further matching against the short codes in the other ARS form.

In the example below, the user wants different routing applied to international calls based on the country code dialed. To do that in the default ARS form would introduce a large number of short codes in the one form, making maintenance difficult.

So the short code matching calls with the international dialing prefix 0 has been set to route matching calls to another ARS form. That form contains short codes for the different country dialing codes of interest plus a default for any others.

The screenshot displays the configuration for two ARS (Automatic Route Selection) entries and a Short Code configuration. The Short Code configuration is for '9x' with Code '9N', Feature 'Dial', Telephone Number 'N', Line Group Id '50: Main', and Locale set to a dropdown. The ARS configuration for ARS Route Id '50' (Main) has a Dial Delay Time of 'System Default (4)', In Service checked, and a table of routes. The ARS configuration for ARS Route Id '51' (International) has a Dial Delay Time of 'System Default (4)', In Service checked, and a table of routes. Blue arrows indicate the flow of configuration from the Short Code to ARS 50, and from ARS 50 to ARS 51.

**Short Code Configuration (9x):**

- Code: 9N
- Feature: Dial
- Telephone Number: N
- Line Group Id: 50: Main
- Locale: [Dropdown]
- Force Account Code:

**ARS Configuration (50 - Main):**

- ARS Route Id: 50
- Route Name: Main
- Dial Delay Time: System Default (4)
- In Service:
- Time Profile: <None>
- Secondary Dial tone: SystemTone
- Check User Call Barring:
- Out of Service Route: <None>
- Out of Hours Route: <None>
- Alternate Route Priority Level: 3
- Alternate Route Wait Time: 30
- Alternate Route: <None>

Code	Telephone Number	Feature	Line Group Id
11	911	Dial Emergency	0
911	911	Dial Emergency	0
0N;	0N	Dial 3K1	51:International
1N;	1N	Dial 3K1	0
XN;	N	Dial 3K1	0
XXXXXXXXXXN	N	Dial 3K1	0

**ARS Configuration (51 - International):**

- ARS Route Id: 51
- Route Name: International
- Dial Delay Time: System Default (4)
- In Service:
- Time Profile: <None>
- Secondary Dial tone: SystemTone
- Check User Call Barring:
- Out of Service Route: <None>
- Out of Hours Route: <None>

Code	Telephone Number	Feature	Line Group Id
0N;	0N	Dial 3K1	1
044N;	044N	Dial 3K1	2
0353N;	0353N	Dial 3K1	2
045N;	045N	Barred	2

**Related links**

[ARS Operation](#) on page 644

**Planning ARS**

Using the methods shown in the previous examples, it is possible to achieve ARS that meets most requirements. However the key to a good ARS implementation is planning.

A number of questions need to be assessed and answered to match the system's call routing to the customer's dialing.

**What** What numbers will be dialed and what needs to be output by the system. What are the different call tariffs and the dialing codes.

**Where** Where should calls be routed.

**Who** Which users should be allowed to use the call routes determined by the previous questions.

**When** When should outgoing external calls be allowed. Should barring be applied at any particular times? Does the routing of calls need to be adjusted for reasons such as time dependant call tariffs.

### Related links

[ARS Operation](#) on page 644

---

## Configuring IP Routes

The system acts as the default gateway for its DHCP clients. It can also be specified as the default gateway for devices with static IP addresses on the same subnet as the system. When devices want to send data to IP addresses on different subnets, they will send that data to the system as their default gateway for onward routing.

The IP Route table is used by the system to determine where data traffic should be forwarded. This is done by matching details of the destination IP address to IP Route records and then using the Destination specified by the matching IP route. These are referred to as 'static routes'.

**Automatic Routing (RIP):** The system can support RIP (Routing Information Protocol) on LAN1 and or LAN2. This is a method through which the system can automatically learn routes for data traffic from other routers that also support matching RIP options, see RIP. These are referred to as 'dynamic routes'. This option is not supported on Linux based servers.

**Dynamic versus Static Routes:** By default, static routes entered into the system override any dynamic routes it learns by the use of RIP. This behavior is controlled by the Favor RIP Routes over static routes option on the **System | System** tab.

**Static IP Route Destinations:** The system allows the following to be used as the destinations for IP routes:

- **LAN1** Direct the traffic to the system's LAN1.
- **LAN2** Traffic can be directed to LAN2.
- **Service** Traffic can be directed to a service. The service defines the details necessary to connect to a remote data service.
- **Tunnel** Traffic can be directed to an IPsec or L2TP tunnel.

**Default Route:** The system provides two methods of defining a default route for IP traffic that does not match any other specified routes. Use either of the following methods:

- **Default Service** Within the settings for services, one service can be set as the **Default Route (Service | Service)**.
- **Default IP Route** Create an IP Route record with a blank IP Address and blank IP Mask set to the required destination for default traffic.

### RIP Dynamic Routing common

Routing Information Protocol (RIP) is a protocol which allows routers within a network to exchange routes of which they are aware approximately every 30 seconds. Through this process, each router adds devices and routes in the network to its routing table.

Each router to router link is called a 'hop' and routes of up to 15 hops are created in the routing tables. When more than one route to a destination exists, the route with the lowest metric (number of hops) is added to the routing table.

When an existing route becomes unavailable, after 5 minutes it is marked as requiring 'infinite' (16 hops). It is then advertised as such to other routers for the next few updates before being removed from the routing table. The system also uses 'split horizon' and 'poison reverse'.

RIP is a simple method for automatic route sharing and updating within small homogeneous networks. It allows alternate routes to be advertised when an existing route fails. Within a large network the exchange of routing information every 30 seconds can create excessive traffic. In addition the routing table held by each system is limited to 100 routes (including static and internal routes).



It can be enabled on LAN1, LAN2 and individual services. The normal default is for RIP to be disabled.

- **Listen Only (Passive):** The system listens to RIP1 and RIP2 messages and uses these to update its routing table. However the system does not respond.
- **RIP1:** The system listens to RIP1 and RIP2 messages. It advertises its own routes in a RIP1 sub-network broadcast.
- **RIP2 Broadcast (RIP1 Compatibility):** The system listens to RIP1 and RIP2 messages. It advertises its own routes in a RIP2 sub-network broadcast. This method is compatible with RIP1 routers.
- **RIP2 Multicast:** The system listens to RIP1 and RIP2 messages. It advertises its own routes to the RIP2 multicast address (249.0.0.0). This method is not compatible with RIP1 routers.

Broadcast and multicast routes (those with addresses such as 255.255.255.255 and 224.0.0.0) are not included in RIP broadcasts. Static routes (those in the IP Route table) take precedence over a RIP route when the two routes have the same metric.

---

## Creating a Virtual WAN Port Procedure

1. Select  **WAN Port**.
2. Click  and select **PPP**.
3. In the **Name** field, enter either **LINEx.y** where:
  - **LINE** must be in uppercase.
  - **x** is the line number. For a PRI/T1 module in Slot A, this will be 1. For a PRI/T1 module in Slot B, this will be 5.
  - **y** is the lowest numbered channel number to be used by the WAN link minus 1. For example, if the lowest channel to be used is channel 1 then  $y = 1 - 1 = 0$ .
4. In the **Speed** field, enter the total combined speed of the maximum number of channels sets in the Service.

In this example, 12 channels x 64000 bits = 76800.

**\* Note:**

The maximum number of channels that can be used will be limited by the number of data channels supported by the system Control Unit and not already in use.

5. In the **RAS Name** field, select the RAS name created when the new Service of that name was created.
6. Click **OK**.

---

## System Events

The system supports a number of methods by which events occurring on the system can be reported. These are in addition to the real-time and historical reports available through the System Status Application (SSA).

### SNMP Reporting

Simple Network Management Protocol (SNMP) allows SNMP clients and servers to exchange information. SNMP clients are built into devices such as network routers, server PC's, etc. SNMP servers are typically PC application which receive and/or request SNMP information. The system SNMP client allows the system to respond to SNMP polling and to send alarm information to SNMP servers.

In order for an SNMP server application to interact with a system, the MIB files provided with the Manager installation software must be compiled into the SNMP server's applications database.

**\* Note:**

The process of 'on-boarding' (refer to the IP Office Installation manual and the IP Office SSL VPN Solutions Guide) may automatically configure SNMP and create a number of SNMP alarm traps. These will override any existing SNMP configuration settings.

### SMTP Email Reporting

The system can send alarms to an SMTP email server. Using SMTP requires details of a valid SMTP email account user name and password and server address. If SMTP email alarms are configured but for some reason the system cannot connect with the SMTP server, only the last 10 alarms are stored for sending when connection is successful. Use of SMTP alarms requires the SMTP server details to be entered in the SMTP tab.

### Syslog Reporting

The system can also send alarms to a Syslog server (RFC 3164) without needing to configure an SNMP server. In addition Syslog output can include audit trail events.

Multiple event destinations can be created, each specifying which events and alarms to include, the method of reporting to use (SNMP, Syslog or Email) and where to send the events. Up to 2 alarm destinations can be configured for SNMP, 2 for Syslog and 3 for SMTP email.

## Related links

[Configuring Alarm Destinations](#) on page 656

---

# Configuring Alarm Destinations

## About this task

The Alarms section of the System Events tab displays the currently created alarm traps. It shows the event destinations and the types of alarms that will trigger the send of event reports. Up to 2 alarm destinations can be configured for SNMP, 2 for Syslog and 3 for SMTP email.

## Procedure

1. In the navigation pane, select **System**.
2. In the details pane, select **System Events** and then select the **Alarms** sub-tab.
3. Use the **Add**, **Remove** and **Edit** controls to alter the traps.
4. Click **Add** or select the alarm to alter and then click **Edit**.
5. For a new alarm, set the **Destination** to either **Trap (SNMP)** or **Syslog** or **Email (SMTP)**.

Note that once a destination has been saved by clicking **OK** it cannot be changed to another sending mode.

6. The remaining details will indicate the required destination information and allow selection of the alarm events to include.
7. When completed, click **OK**.
8. Click **OK** again.

## Related links

[System Events](#) on page 655

---

# Configuring authorization codes

## \* Note:

In release 9.1, authorization codes can no longer be associated with User Rights. If an authorization code was configured in relationship with User Rights in an earlier release configuration, this authorization code will be lost during upgrade. The administrator must re-configure the authorization code, after upgrade. The authorization code must be associated with a user.

Authorization codes are enabled by default.

A user dials a number that matches a short code set to **Force Authorization Code**. The user is prompted to enter an authorization code.



They dial their authorization code. If a matching entry is found in **Authorization Codes** records the system checks the corresponding user. Note that the user checked does not necessarily need to be connected with the user dialing or the user whose extension is being used to make the call.

The dial string is checked against the short codes with the matching user. If it matches a dial short code or no short code the call is allowed, otherwise it is blocked. Note that the short code is not processed, it is just checked for a match. If multi-tier authorization codes are required there must be blocking (busy) short codes (or a wild card '?')

### Example:

A restaurant has a number of phones in publicly accessible areas and want to control what calls can be made by staff. Staff must not be able to dial long distance numbers. staff should be able to dial local and cell phone numbers.

<b>ARS Table</b>
In the Main (50) ARS table, add the following short codes: <ul style="list-style-type: none"> <li>• 044XXXXXXXXXX/Dial/044N/</li> <li>• 01XXXXXXXXXX/Dial/01N/Force Auth Code checked</li> </ul>
<b>Authorization Codes</b>
Configure an authorization code for each staff member that is allowed to make long distance calls. For example, for staff members Alice and Bob: <p>AuthCode: <b>2008 - Alice</b></p> <p>AuthCode: <b>1983 - Bob</b></p>

It is recommended to use short codes that use X characters to match the full number of characters to be dialed. That ensures that authorization code entry is not triggered until the full number has been dialed rather than mid-dialing. For example 09 numbers are premium rate in the UK, so you would create a **09XXXXXXXXX/Dial/N** short code set to Forced Authorization. In the associated user or user right short code it is recommended to use 09N type short codes.

System short codes that route to ARS will not have their **Force Authorization Code** setting used. However short codes within an ARS table will have their **Force Authorization Code** setting used.

### Forcing Authorization Codes

There are two methods to force a user to enter an authorization code in order to complete dialing an external call.

- **To Force Authorization Codes on All External Calls** A user can be required to enter an authorization code for all external calls. This is done by selecting Force Authorization Code (**User | Telephony | Supervisor Settings**).
- **To Force Authorization Codes on Specific Calls** To require entry of an authorization code on a particular call or call type, the Force Authorization Code option should be selected in the short code settings. This can be used in user or system short codes in order to apply its effect to a user or all users respectively. You need to ensure that the user cannot dial the same number by any other method that would by pass the short code, for example with a different prefix.

### Related links

[Entering an Authorization Code](#) on page 658

## Entering an Authorization Code

Where possible, when an authorization code is required, the user can enter it through their phones display. However, this is not possible for all type of phone, for example it is not possible with analog phones and Avaya XX01 or XX02 phones. The users of these device must either enter the authorization code using a short code set to the Set Authorization Code feature immediately before making the call.

When entry of an authorization code is triggered, the user can enter any authorization code with which they are directly associated.

Note the following.

- If authorization code entry is setup for a particular number, calls forwarded or transferred to that number will also trigger authorization code entry.
- On systems using line appearances to BRI trunk channels to make outgoing calls, authorization code entry may not be triggered. This can be resolved by adding a short code such as [9]XN;/Dial/XN/0 (adjust the prefix and line group as necessary).

### Related links

[Configuring authorization codes](#) on page 656

---

## Preventing Toll Bypass

Use this procedure to prevent toll bypass in Enterprise Branch and Small Community Network (SCN) deployments. Toll bypass is prevented by only allowing PSTN calls where the originating location and terminating location are the same.

The location of non-IP lines is the same as the system location. If an IP address is not resolved to any location, then that device is assumed to be in the system location. The location of public IP lines must be configured to same as PSTN termination location.

The **Location** field for extensions with simultaneous login must be automatic and the location tab must be properly configured for the IP range.

**Enterprise Branch deployments:** All the distributed users must be in the same location as system location. Users registering from a location different from the system location are not supported.

### Procedure

1. In the navigation pane on the left, select **System**.
2. In the details pane, click the **Telephony** tab.
3. Under **Telephony**, click the **Telephony** tab.

4. On the **Telephony** tab:
  - a. Click the check box to turn **Restrict Network Interconnect** on.
  - b. Click the check box to turn **Include location specific information** on.
 

Setting the two configuration setting on the **Telephony** tab adds a **Network Type** field to the configuration settings for each trunk.
5. For Enterprise Branch deployments, open the **SM Line | Session Manager** tab. For SCN deployments, open the **IP Office Line | Line** tab.
6. If the line is a PSTN trunk (includes SIP), set **Network Type** to **Public**. If the line is an enterprise trunk, set the **Network Type** to **Private**.
7. If the **Network Type** is **Private**, the **Include location specific information** field is available.
 

If the line is connected to an Avaya Aura® system release 7.0 or higher, or an IP Office release 9.1 or higher, set **Include location specific information** to **On**.

## Configuring unknown locations

Use this procedure to configure extensions where the location is unknown.

### Procedure

1. In the navigation pane, select **Location**.
2. Enter a **Location Name**.
3. Set **Parent Location for CAC** to **Cloud**.
4. In the **Extension | Extn** tab, set the **Location** field to the location defined in step 2.

---

## Call Barring

### Related links

[Applying Call Barring](#) on page 659

[Overriding call barring](#) on page 660

---

## Applying Call Barring

Call barring can be applied in a number of ways.

### Barring a User From Receiving Any External Calls:

For each user, the **Incoming Call Bar** setting (**User | Telephony | Supervisor Settings** ) can be selected to stop that user from receiving any external calls.

### Barring a User From Making Any External Calls:

For each user, the **Outgoing Call Bar** setting (**User | Telephony | Supervisor Settings**) can be selected to stop that user from making any external calls.

### **Barring Particular Numbers/Number Types:**

System short codes are used to match user dialing and then perform a specified action. Typically the action would be to dial the number to an external line. However, short codes that match the dialing of particular numbers or types of numbers can be added and set to another function such as Busy. Those short codes can be added to a particular user, to a User Rights associated with several users or to the system short codes used by all users.

The system allows short codes to be set at user, user rights, system and least cost route. These have a hierarchy of operation which can be used to achieve various results. For example a system short code for a particular number can be set to busy to bar dialing of that number. For a specific user, a user short code match to the same number but set to Dial will allow that user to override the system short code barring.

### **Using Account Codes:**

The system configuration can include a list of account codes. These can be used to restrict external dialing only to users who have entered a valid account code.

- **Forcing Account Code Entry for a User:** A user can be required to enter an account code before the system will return dialing tone. The account code that they enter must match a valid account code stored in the system configuration. The setting for this is **Force Account Code (User | Telephony | Supervisor Settings)**
- **Forcing Account Code Entry for Particular Numbers:** Each system short code has a Force Account Code option. Again the account code entered must match a valid account code stored in the system configuration. for the call to continue.

### **Barring External Transfers and Forwards:**

A user cannot forward or transfer calls to a number which they cannot normally dial. In addition there are controls which restrict the forwarding or transferring of external calls back off-switch. See [Off-Switch Transfer Restrictions](#) on page 731.

### **Related links**

[Call Barring](#) on page 659

---

## **Overriding call barring**

When a system or user short code is configured to bar outgoing calls, you can override call barring. Typically, this configuration is used for a phone in a shared or public area. By default, the phone has outgoing calls barred. The administrator can override call barring for specific dialed numbers by entering numbers with a record in the external directory. When the dialed number exists in the external directory and the **Directory Overrides Call Barring** setting is enabled, call barring is overridden.

The System Directory entries must use the format (shortcode)number. For example, if the number to dial is 61234, where 6 is the shortcode used to dial externally and 1234 is the number, the System Directory entry must be (6)1234. If the dial shortcode contains a name string rather than digits, then **Directory Overrides Call Barring** will not work.

The **Directory Overrides Barring** setting is located on the **System | Telephony | Telephony** tab.

For information on the directory, see the description for the **System | Directory Services** tab.

### **Server Edition configuration**

For Server Edition deployments, the **Directory Overrides Barring** must be enabled on each node. It is not a system wide setting.

For example, if the Primary Server uses an IP500 V2 expansion system as an ISDN gateway, **Directory Overrides Barring** must be enabled on the Primary Server for Primary Server users dialing on external ISDN lines. For the IP500 V2 expansion users, **Directory Overrides Barring** must be enabled on the IP500 V2 expansion system.

It is recommend that the short code configured to dial externally on ISDN lines be the same on all nodes. For example, if Primary Server users and IP500 V2 expansion users want to reach PSTN number 123456789 on ISDN lines, configure the dial codes as follows.

- Primary Server: 6N/Dial/6N/XX (XX is the line group ID for the SCN line)
- IP500 V2 expansion: 6N/Dial/N/YY (YY is the line group ID for ISDN line)
- Directory Entry number defined on Primary Server: (6)123456789

### **Related links**

[Call Barring](#) on page 659

# Chapter 13: Configure User Settings

## Related links

- [User Management Overview](#) on page 663
- [Configuring User Rights](#) on page 664
- [Configuring Gmail Integration](#) on page 668
- [Call Intrusion](#) on page 669
- [Call Tagging](#) on page 675
- [Call Waiting](#) on page 675
- [Call Restriction](#) on page 676
- [Centralized Call Log](#) on page 677
- [Centralized call log field descriptions](#) on page 678
- [Call scenarios](#) on page 680
- [Centralized call logging controls](#) on page 681
- [Centralized Personal Directory](#) on page 683
- [Account Code Configuration](#) on page 683
- [Coverage Groups](#) on page 685
- [DND, Follow Me and Forwarding](#) on page 685
- [Hot Desking](#) on page 699
- [Group Operation](#) on page 705
- [Malicious Call Tracing \(MCID\)](#) on page 715
- [Message Waiting Indication](#) on page 715
- [Mobile Call Control](#) on page 718
- [Twinning](#) on page 723
- [Private Calls](#) on page 726
- [System Phone Features](#) on page 727
- [The 'No User' User](#) on page 728
- [Transferring Calls](#) on page 729
- [Avaya cloud authorization](#) on page 738
- [Configuring automatic synchronization](#) on page 738
- [Enabling Avaya cloud account authorization](#) on page 739
- [Configuring token cache time](#) on page 740
- [Apple push notification services](#) on page 740
- [Enabling Apple push notifications](#) on page 741

---

# User Management Overview

Users are the people who use the system. They do not necessarily have to be an extension user, for example users are used for RAS dial in data access. In addition, more users can be created than there are extensions, with users logging in to an extension when they want to receive calls.

By default, a user is automatically created to match each extension. They are numbered from 201 upwards and the first 16 are placed in the hunt group Main (200), which is the default destination for incoming calls.

## Terminology

**Standard User:** A standard user.

**Centralized User:** Centralized users can be provisioned for enterprise branch deployments.

**No User:** Used to apply settings for extensions which currently have no associated user. The **SourceNumbers** settings of the **NoUser** user is used to configure a number of special options. These are then applied to all users on the system.

**Remote Manager:** Used as the default settings for dial in user connections.

**Hot Desking User:** Users with a Login Code can move between extensions by logging in and off.

## Deleting a User

When a user is deleted, any calls in progress continue until completed. The ownership of the call is shown as the NoUser user. Merging the deletion of a user causes all references to that deleted user to be removed from the system.

## Changing a User's Extension

Changing a user's extension number automatically logs the user in on the matching base extension if available and the user doesn't have Forced Login enabled. If **Forced Login** is enabled, then the user remains on the current extension being used until they log out and log in at the new extension.

Note that changing a user's extension number affects the user's ability to collect Voicemail messages from their own extension. Each user's extension is set up as a "trusted location" under the Source Numbers tab of the User configuration form. This "trusted location" allows the user to dial \*17 to collect Voicemail from his own extension. Therefore if the extension number is changed so must the "trusted location".

The following related configuration items are automatically updated when a user extension is changed:

- User, Coverage and Bridged Appearance buttons associated with the user.
- Hunt group membership (disabled membership state is maintained).
- Forwards and Follow Me's set to the user as the destination.
- Incoming call routes to this destination.
- Dial in source numbers for access to the user's own voicemail.
- Direct call pickup buttons are updated.
- The extension number of an associated extension is updated.

## Server Edition User Management

In a Server Edition network, individual users are still added to the configuration of a particular server. Typically they are added to the configuration of the server that hosts the user's physical extension or supports their main place of work. That server is treated as the host system for the user. However, once a user is added to the configuration of a particular system, you can use Manager and Web Manager to manage all users in the Server Edition solution.

## Centralized User Management

**Centralized Users** are provisioned for enterprise branch deployments. **Centralized Users** are registered with Session Manager and are able to utilize telephony features provided by Communication Manager. The **Centralized User** profile is applicable to both SIP and analogue extensions. For more information, see *Administering Centralized Users for an IP Office™ Platform Enterprise Branch*. The following requirements must be met when provisioning a centralized user:

- An SM line must be configured on the system.
- The user must be provisioned with an existing extension.
- The extension **Base Extension** value must match the centralized extension value.
- Centralized users must be configured with a password for SIP registration on Session Manager. The password is set in User | Telephony | Supervisor Settings | Login Code field.

### Related links

[Configure User Settings](#) on page 662

---

## Configuring User Rights

For most settings in a user rights template, the adjacent drop down list is used to indicate whether the setting is part of the template or not. The drop down options are:

- **Apply User Rights Value** Apply the value set in the user rights template to all users associated with the template.
  - The matching user setting is grayed out and displays a  lock symbol.
  - Users attempting to change the settings using short codes receive inaccessible tone.
- **Not Part of User Rights** Ignore the user rights template setting.

### Default User Rights

For defaulted systems, the following user rights are created as a part of the default configuration. Fields not listed are not part of the user rights.

#### **Note:**

When a user logs in as an Outbound Contact Express agent, the Outdialer user rights are automatically applied. When the agent logs out, the previous user rights are applied.

✓ = Set to On. ✗ = Set to Off. - = Not part of the user rights.



User Rights	Call Center Agent	Boss	Application	Default	IP Hard Phone	Mailbox	Paging	Outdialer
Priority	✓ 5	✓ 5	✓ 5	✓ 5	✓ 5	✓ 5	✓ 5	✓ 5
Voicemail	-	-	-	-	-	✓	-	✗
Voicemail Ringback	✗	✗	✗	✗	✗	✗	-	✗
Outgoing Call Bar	✗	✗	✗	✗	✗	✗	✗	✓
No Answer Time	✓ 0	✓ 0	✓ 0	✓ 0	✓ 0	✓ 0	✓ 0	0
Transfer Return Time	✓ 0	✓ 0	✓ 0	✓ 0	✓ 0	✓ 0	✓ 0	0
Individual Coverage Time	✓ 10	✓ 10	✓ 10	✓ 10	✓ 10	✓ 10	✓ 10	10
Busy on Held	✗	✗	✗	✗	✗	-	-	✓
Call Waiting	✗	✗	✓	✗	✗	✗	✗	✗
Can Intrude	✗	✗	✗	✗	✗	✗	✗	✗
Cannot be Intruded	✗	✗	✓	✓	✓	✗	✗	✗
Deny Auto Intercom Calls	-	-	-	-	-	-	-	✗
Enable Inhibit Off-Switch Forward/Transfer	-	-	-	-	-	-	-	✓
Enable Outgoing Call Bar	-	-	-	-	-	-	-	✓
Centralized Logging	-	-	-	-	-	-	-	✗

Table continues...



User Rights	Call Center Agent	Boss	Application	Default	IP Hard Phone	Mailbox	Paging	Outdialer
Force Login	✓	-	-	-	-	-	-	
Force Account Code	✗	✗	✗	✗	✗	✗	✗	
Button Programming	1: a= 2: b= 4: HGE na 5: DNDO n 6: Busy	1: a= 2: b= 3: c= 6: DNDO n 7: Dial *17	✓	1: a= 2: b= 3: c=	1: a= 2: b= 3: c= 6: Dial *17	✓	-	1: a= 2: b= 3: Supervisor 4: Extn Logout

**Related links**

- [Configure User Settings](#) on page 662
- [Adding User Rights](#) on page 666
- [Creating a User Right Based on an Existing User](#) on page 666
- [Associating User Rights to a User](#) on page 667
- [Copy User Rights Settings over a User's Settings](#) on page 667

## Adding User Rights

**About this task**  
**Procedure**

1. Select  **User Rights**.
2. Click  and select **User Rights**.
3. Enter a name.
4. Configure the user rights as required.
5. Click **OK**.

**Related links**

- [Configuring User Rights](#) on page 664

## Creating a User Right Based on an Existing User

**About this task**

## Procedure

1. Select  **User Rights**.
2. In the group pane, right-click and select **New User Rights from a User**.
3. Select the user and click **OK**.

### Related links



[Configuring User Rights](#) on page 664

---

## Associating User Rights to a User

### About this task

#### Procedure

1. Select  **User Rights** or  **User**.
2. In the group pane, right-click and select **Apply User Rights to Users**.
3. Select the user rights to be applied.
4. On the **Members of this User Rights** sub tab select the users to which the user rights should be applied as their Working Hours User Rights.
5. On the **Members when out of hours** sub tab select which users should use the selected user rights as their out of hours user rights.
6. Click **OK**.

### Related links

[Configuring User Rights](#) on page 664

---

## Copy User Rights Settings over a User's Settings

### About this task

This process replaces a user's current settings with those that are part of the selected user rights. It does not associate the user with the user rights.

#### Procedure

1. Select  **User Rights**.
2. In the group pane, right-click and select **Copy user rights values to users**.
3. Select the user rights to be applied.
4. Click **OK**.

## Related links

[Configuring User Rights](#) on page 664

---

# Configuring Gmail Integration

You can integrate the Google Gmail application into Voicemail Pro in order to use a Gmail account for voicemail to email functions.

### Important:

- Due to changes in the Gmail API, support for this feature has been withdrawn. Support will be re-enabled in a future release.

The supported functions are:

- **Forward:** Voicemail messages are sent as email to the Gmail account of a user. Users can use Gmail to retrieve and manage emails.
- **Copy:** Copies of voicemail messages are sent as email to the Gmail account of a user. The message is also stored locally on the Voicemail Pro server.
- **Alert:** An email is sent to the Gmail account of a user indicating the arrival of a new voicemail.

For the forwarding function:

- Up to 250 users are supported.
- The maximum message length is 7 minutes or 14 minutes when using companded.
- Messages can be accessed using Visual Voice but not one-X Communicator.

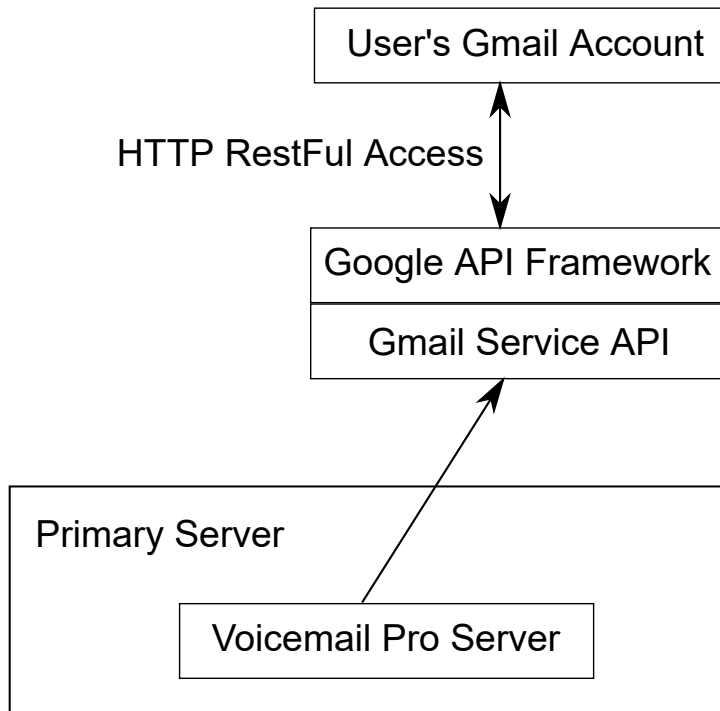
**Related links**

[Configure User Settings](#) on page 662

---

## Call Intrusion

The system supports several different methods for call intrusion. The method used affects which parties can hear and be heard by other parties following the intrusion. Intrusion features are supported across a multi-site network

In the scenarios below, user A is on a call with B who may be internal or external. User C invokes one of the call intrusion methods targeting user A.

Feature	Description	Privacy Settings		
		User	Target	
		Can Intrude	Cannot Be Intruded	Private Call
<p>Call Listen</p> 	<p>This feature allows you to monitor another user's call without being heard. Monitoring can be accompanied by a tone heard by all parties. Use of the tone is controlled by the Beep on Listen setting on the System   Telephony   Tones &amp; Music tab. The default for this setting is on. If enabled, this is the only indication of monitoring given to the monitored user. There is no phone display indication of monitoring.</p>	Used	Used	Used
<p>Call Intrude</p> 	<p>This feature allows you to intrude on the existing connected call of the specified target user. All call parties are put into a conference and can talk to and hear each other. A <b>Call Intrude</b> attempt to a user who is idle becomes a Priority Call.</p>	Used	Used	Used

Table continues...

Feature	Description	Privacy Settings		
		User	Target	
		Can Intrude	Cannot Be Intruded	Private Call
Call Steal	<p>This function can be used with or without a specified user target.</p> <p>If the target has alerting calls, the function will connect to the longest waiting call.</p> <p>If the target has no alerting calls but does have a connected call, the function will take over the connected call, disconnecting the original user.</p> <p>This usage is subject to the <b>Can Intrude</b> setting of the <b>Call Steal</b> user and the <b>Cannot Be Intruded</b> setting of the target.</p> <p>If no target is specified, the function attempts to reclaim the user's last ringing or transferred call if it has not been answered or has been answered by voicemail.</p>	Used	Used	Used

*Table continues...*

Feature	Description	Privacy Settings		
		User	Target	
		Can Intrude	Cannot Be Intruded	Private Call
Dial Inclusion 	<p>This feature allows you to intrude on another user's call to talk to them. Their current call is put on hold while you talk and automatically reconnected when you end the intrusion. The intruder and the target extension can then talk but cannot be heard by the other party. This can include intruding into a conference call, where the conference will continue without the intrusion target.</p> <p>During the intrusion all parties hear a repeated intrusion tone. When the intruder hangs-up the original call parties are reconnected. Attempting to hold a dial inclusion call simply ends the intrusion. The inclusion cannot be parked.</p>	Used	Used	Used

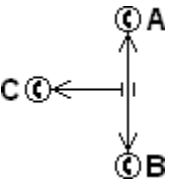
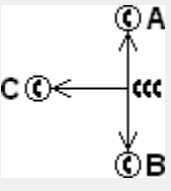
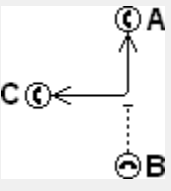
*Table continues...*



Feature	Description	Privacy Settings		
		User	Target	
		Can Intrude	Cannot Be Intruded	Private Call
<p>Whisper Page</p> 	<p>This feature allows you to intrude on another user and be heard by them without being able to hear the user's existing call which is not interrupted. For example: User A is on a call with user B. When user C intrudes on user A, they can be heard by user A but not by user B who can still hear user A. Whisper page can be used to talk to a user who has enabled private call.</p>	Used	Used	Not Used
<p>Coaching Intrusion</p> 	<p>This feature allows the you to intrude on another user's call and to talk to them without being heard by the other call parties to which they can still talk. For example: User A is on a call with user B. When user C intrudes on user A, they can hear users A and B but can only be heard by user A.</p>	Used	Used	Used

Table continues...

Feature	Description	Privacy Settings		
		User	Target	
		Can Intrude	Cannot Be Intruded	Private Call
Request Coaching Intrusion 	This feature allows you to request a call intrusion. While on a call, user A indicates to user C a request for coaching support. When user C intrudes on user A, they can hear users A and B but can only be heard by user A.	Used	Used	Used
Call Appearance	In addition to making and answering calls, appearance buttons that indicate 'in use elsewhere' can be pressed in order to join that call.  The <b>Can Intrude</b> setting of the user is not used. The <b>Cannot Be Intruded</b> setting of the longest present internal party in the call is used.	Not Used	Used	Used
Bridged Appearance		Not Used	Used	Used
Line Appearance		Not Used	Used	Used

**Warning:**

The use of features to listen to a call without the other call parties being aware of that monitoring may be subject to local laws and regulations. Before enabling the feature you must ensure that you have complied with all applicable local laws and regulations. Failure to do so may result in severe penalties.

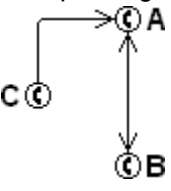
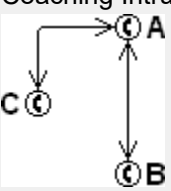
**Intrusion Privacy Controls**

The ability to intrude and be intruded is controlled by two configuration settings, the Can Intrude (User | Telephony | Supervisor Settings) setting of the user intruding and the Cannot Be Intruded (User | Telephony | Supervisor Settings) setting of target being intruded on. The setting of any other internal party is ignored. By default, no users can intrude and all users are set to cannot be intruded.

For intrusion using appearance buttons, the user's **Can Intrude** setting is not used. The **Cannot Be Intruded** setting of the longest present internal party in the call is used.

A user who can normally be intruded on can indicate that a call is a private call by using a Private Call short code or programmable button. While private call status is enabled, no intrusion is allowed except for **Whisper Page** intrusion.

In addition to the options above, **Call Listen** can only be used to intrude on calls by users in the user's Monitor Group (User | Telephony | Supervisor Settings).

For the **Call Steal** function, the **Can Be Intruded** setting is used if the call is connected.

#### Related links

[Configure User Settings](#) on page 662

---

## Call Tagging

Call tagging associates a text string with a call. That string remains with the call during transfers and forwards. That includes calls across a multi-site network.

On Avaya display phones, the text is shown whilst a call is alerting and is then replaced by the calling name and number when the call is connected. On analog phones with a caller ID display, the tag text replaces the normal caller information.

Applications such as SoftConsole display any call tag associated with a call. If the call is parked, the tag is shown on the call park slot button used. A call tag can be added when making a call using SoftConsole or one-X Portal. A tag can be added to a call by an Incoming Call Route or by an Voicemail Pro Assisted Transfer action.

#### Related links

[Configure User Settings](#) on page 662

---

## Call Waiting

Call waiting allows a user who is already on a call to be made aware of a second call waiting to be answered.

#### User Call Waiting

Call waiting is primarily a feature for analog extension users. The user hears a call waiting tone and depending on the phone type, information about the new caller may be displayed. The call waiting tone varies according to locale.

For Avaya feature phones with multiple call appearance buttons, call waiting settings are ignored as additional calls are indicated on a call appearance button if available.

To answer a call waiting, either end the current call or put the current call on hold, and then answer the new call. Hold can then be used to move between the calls.

Call waiting for a user can be enabled through the system configuration (User | Telephony | Call Settings | Call Waiting On) and through programmable phone buttons.

Call waiting can also be controlled using short codes. The following default short codes are available when using Call Waiting.

**\*15 - Call Waiting On** Enables call waiting for the user.

**\*16 - Call Waiting Off** Disables call waiting for the user.

**\*26 - Clear Call and Answer Call Waiting** Clear the current call and pick up the waiting call.

### Hunt Group Call Waiting

Call waiting can also be provided for hunt group calls. The hunt group **Ring Mode** must be **Collective Call Waiting**.

On phones with call appearance buttons, the call waiting indication takes the form of an alert on the next available call appearance button. On other phones, call waiting indication is given by a tone in the speech path (the tone is locale specific).

The user's own **Call Waiting** setting is overridden when they are using a phone with call appearances. Otherwise the user's own **Call Waiting** setting is used in conjunction with the hunt group setting.

### Related links

[Configure User Settings](#) on page 662

---

## Call Restriction

Call barring can be applied in a range of ways.

**Barring a User From Receiving Any External Calls** For each user, Incoming Call Bar (User | Telephony | Supervisor Settings) can be selected to stop that user from receiving any external calls.

**Barring a User From Making Any External Calls** For each user, Outgoing Call Bar (User | Telephony | Supervisor Settings) can be selected to stop that user from making any external calls.

**Barring Particular Numbers/Number Types** System short codes are used to match user dialing and then perform a specified action. Typically the action would be to dial the number to an external line. However, short codes that match the dialing of particular numbers or types of numbers can be added and set to another function such as Busy. Those short codes can be added to a particular user, to a User Rights associated with several users or to the system short codes used by all users.

The system allows short codes to be set at user, user rights, system and least cost route. These have a hierarchy of operation which can be used to achieve various results. For example a system

short code for a particular number can be set to busy to bar dialing of that number. For a specific user, a user short code match to the same number but set to Dial will allow that user to override the system short code barring.

**Using Account Codes** The system configuration can include a list of account codes. These can be used to restrict external dialing only to users who have entered a valid account code.

- **Forcing Account Code Entry for a User** A user can be required to enter an account code before the system will return dialing tone. The account code that they enter must match a valid account code stored in the system configuration. The setting for this is Force Account Code (User | Telephony | Supervisor Settings).
- **Forcing Account Code Entry for Particular Numbers** Each system short code has a Force Account Code option. Again the account code entered must match a valid account code stored in the system configuration. for the call to continue.

**Barring External Transfers and Forwards** A user cannot forward or transfer calls to a number which they cannot normally dial. In addition there are controls which restrict the forwarding or transferring of external calls back off-switch. See Off-Switch Transfer Restrictions.

#### Related links

[Configure User Settings](#) on page 662

---

## Centralized Call Log

IP Office can store a centralized call log for you. The centralized call log contains up to 60 call records for your calls (Server Edition) or 30 call records (IP500 V2). Each new call record replaces the oldest previous record when it reaches the limit.

On Avaya phones with a fixed **Call Log** or **History** button (1400, 1600, 9500, 9600, J100 Series), that button can be used display your centralized call log. You can use the call log to make calls or to store contacts as a personal speed dial. You can also edit the call log to remove records. The same call log is also used if the user logs into one-X Portal.

#### **Note:**

Avaya Workplace Client also now uses the centralized call log.

The centralized call log moves with you if you log on and off from different phones and / or Avaya Workplace Client. This includes hot desking within a network.

The missed call count is updated per user and not per call when a centralized call log is enabled. The missed call count is the sum of all the missed calls from a user, even if some of those missed calls have been reviewed in the call history screen already.

The user's call log records are stored by the system that is their home system, that is, the one on which they are configured. When the user is logged in on another system, new call log records are sent to the user's home system, but using the time and date on the system where the user is logged in.

**Related links**

[Configure User Settings](#) on page 662

## Centralized call log field descriptions

The following fields is included in each centralized call log record:

Field	Description
<b>Name</b>	Specifies the name of the caller or the party called, if available. The name can be up to 31 characters.  This text is similar to that shown on the phone display of phones when they receive the call. For example, on forwarded call details of the original target and the caller name are included, Bob > Sue.
<b>Number</b>	Specifies the number of the call. The number can be up to 31 digits.
<b>Tag</b>	The text tag associates a text string with a call. The string remains with the call during transfers and forwards. That includes calls across a multi-site network.  The text tag can be up to 31 characters. The tag is not shown within the call log display on phones.
<b>Time and Date</b>	The time and date of the call using the system time.
<b>Duration</b>	The call duration. For an outgoing and answered calls, this is the call connection time. For missed calls, this is the call ringing time.

*Table continues...*

Field	Description
<b>Record Type</b>	<p>The call log records can be <b>Incoming</b>, <b>Outgoing</b>, or <b>Missed</b>. Note that these are calls to or from the user, not the phone; hence, it can include calls handled through a twinned device such as when using mobile call control.</p> <ul style="list-style-type: none"> <li>• <b>Incoming</b>: These are the calls to the user that the user has answered. This includes <ul style="list-style-type: none"> <li>- The calls that the user answers on a twinned device.</li> <li>- The outgoing calls that are transferred to and answered by the user.</li> </ul> </li> <li>• <b>Outgoing</b>: These are the calls made by the user.</li> <li>• <b>Missed</b>: These are the calls to the user that they did not answer. This includes calls while the user is logged off or in Do Not Disturb state.</li> <li>• Missed call records include an indication of what happened to the missed call. It displays the following options , or <ul style="list-style-type: none"> <li>- <b>Answered by Another</b></li> <li>- <b>Answered by Voicemail</b></li> <li>- <b>Lost</b> (not answered on the system).</li> </ul> </li> <li>• Missed call records are also marked as either acknowledged or unacknowledged. If the user's call log contains any unacknowledged call log records, the <b>Call Log</b> lamp is enabled when using a 1608 or 1616 phone. From the phone, viewing an unacknowledged record changes it to acknowledged.</li> <li>• If the user has also configured to included missed hunt group calls in their call log, those are also marked as acknowledged or unacknowledged.</li> </ul>
<b>Count</b>	<p>Specifies the number of times a matching call has been logged. A matching call is one with the same name, number and type. Only the latest record is kept for matching calls, with the call count increased by one.</p>

**Related links**

[Configure User Settings](#) on page 662

## Call scenarios

This list summarizes how the your call log is used in some common call scenarios.

Scenarios	User Call Log Notes
<b>Authorization/Account Codes</b>	Account and authorization codes used as part of a call. The call logs do not include these codes.
<b>Automatic Callback</b>	If answered, they will show as an outgoing call to the target.
<b>Application Calls</b>	Calls made and answered using applications are logged as if you made or answered the call using an extension.
<b>Conference Calls</b>	Ad-hoc Conference calls are not included in the call log. Meet-me Conference calls are included in the call log.
<b>Hold</b>	When you hold and then un-hold a call, the call duration includes the time the call was on hold.
<b>Follow-Me</b>	Calls that still appear in the call log. The follow-me calls do not appear in the call log even if you set Follow-Me.
<b>Forward on Busy</b>	When answer, it records <b>Missed-Answered by Other</b> in the call log. When the forwarded to voicemail, call log records <b>Missed-Answered by Voicemail</b> .
<b>Forward on No Answer</b>	
<b>Forward Unconditional</b>	When forwarding to another number, there will be no record of forwarded calls in the forwarding users call log. When using the To Voicemail option, the forwarded call will by logged as a Missed - Answered by Voicemail call record.
<b>Page Calls</b>	Page calls are not included in any of the call logs unless the page is answered (by pressing conference). When answered, the call logs the page as a normal call between the two involved users.
<b>Park</b>	Retrieving a call from Park (even if you parked the call) is logged as an incoming call.
<b>Short Codes</b>	Call log records all outgoing and answered calls. Calls made using Break Out are not included in call logs.
<b>Suppressed Digits</b>	Calls made with digit suppression enabled (AD suppress button) are not included in the call log.

*Table continues...*



Scenarios	User Call Log Notes
<b>Transfers</b>	<p>If you answer and accept a supervised transfer, you will have an incoming calls records-one for the transfer inquiry call and one for the transferred call.</p> <p>If you are the target of an unsupervised transfer, you will have an Incoming or Missed call log.</p> <p>The call log records the attended transferred call (originally an outgoing call) as an incoming call.</p>
<b>Twinning and Mobility</b>	<p>When you have a twinned device (either internal twinning or mobile twinning), the call log operates regardless of which method you use to make or answer calls.</p> <p>Calls between the twinned devices, that is, the user transferring a call between devices, are not included in their call log.</p> <p>Call log includes calls made using mobile call control or a Avaya one-X<sup>®</sup> Mobile client.</p>

**Related links**

[Configure User Settings](#) on page 662

---

## Centralized call logging controls

The centralized call log includes the following controls for all calls.

Controls	Description
<b>User Setting</b>	As a user, you can set the centralized call log settings through the user settings <b>User &gt; Telephony &gt; Call Log</b> or through your associated user rights <b>User Rights &gt; Telephony &gt; Call Log</b> .
<b>Centralized Call Log</b>	<p>Default: ON</p> <p> As a user, you can enable (ON) or disable (OFF) the centralized call log settings. The default setting is set to ON to match (<b>Default Centralized Call Log On</b>) the system setting <b>System &gt; Telephony &gt; Call Log</b> If OFF is selected, the call log shown on the phone is the local call log stored by the phone.</p>
<b>System Settings</b>	<b>System &gt; Telephony &gt; Call Log</b>

*Table continues...*

Controls	Description									
<p><b>Default Centralized Call Log On</b></p>	<p>Default: ON.</p> <p>Enabling the <b>Default Centralized Call Log On</b> setting; call logs are stored in system by default. You can view this call log on <b>Call Log</b> or <b>History</b> button on your phone. As a user, you can enable (ON) or disable (OFF) the centralized call log settings using <b>Centralized Call Log</b> setting. (<b>User &gt; Telephony &gt; Call Log</b>).</p>									
<p><b>Log Missed Calls Answered at Coverage</b></p>	<p>Default: OFF</p> <p>When the <b>Log Missed Calls Answered at Coverage</b> setting is enabled, it logs the calls in the centralized call log answered by a covering user. This option applies for calls answered elsewhere (covered), call coverage (call coverage buttons or coverage group), bridged appearance button, user BLF, voicemail, and so on.</p> <table border="1" data-bbox="854 814 1468 940"> <thead> <tr> <th>Setting</th> <th>Targeted User</th> <th>Covering User</th> </tr> </thead> <tbody> <tr> <td><b>OFF</b></td> <td>Nothing</td> <td>Answered Call</td> </tr> <tr> <td><b>ON</b></td> <td>Missed Call</td> <td>Answered Call</td> </tr> </tbody> </table>	Setting	Targeted User	Covering User	<b>OFF</b>	Nothing	Answered Call	<b>ON</b>	Missed Call	Answered Call
Setting	Targeted User	Covering User								
<b>OFF</b>	Nothing	Answered Call								
<b>ON</b>	Missed Call	Answered Call								
<p><b>Log Missed Hunt Group Calls</b></p>	<p>Default: OFF</p> <p>By default, hunt group calls are not included in centralized call log unless answered by your. Selecting <b>Log Missed Hunt Group Calls</b> settings, a separate call log is available for each hunt group of calls that are not answered by anyone. It includes hunt group calls that go to voicemail.</p> <p>The system records the missed hunt group calls. The system stores up to 10 call records for each hunt group. The new call record replaces the oldest record when it reaches the limit.</p> <p>Within the user call log setting (<b>User &gt; Telephony &gt; Call Log</b>), the list of hunt groups allows selection displays the missed hunt groups' call records as part of the centralized call log.</p>									

**Related links**

[Configure User Settings](#) on page 662

## Centralized Personal Directory

Each system user is able to have up to 250 personal directory records stored by the system. A user's personal directory is also usable with 1400, 1600, 9500 and 9600 Series phones with a **CONTACTS** button. The user can view these records and use them to make calls.

1400, 1600, 9500 and 9600 Series phone users can edit their personal directory records through the phone. The user personal directory records can be edited using the Manager User | Personal Directory menu.

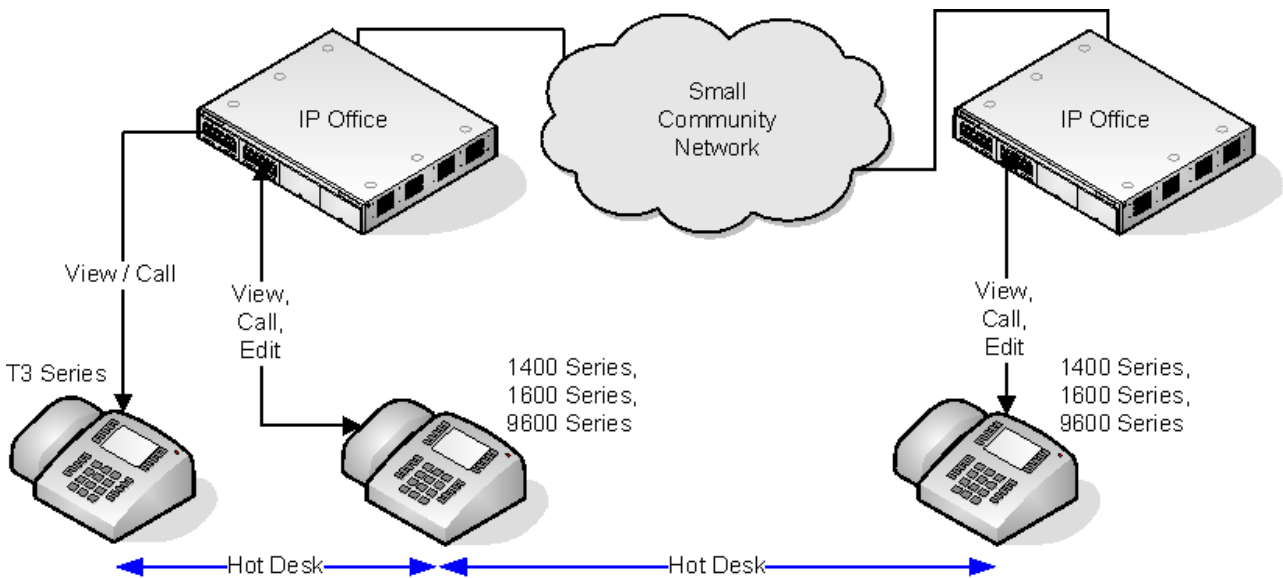

When the user hot desks to another phone that supports the centralized personal directory, their personal directory records become accessible through that phone. That also includes hot desking to another system in the network.

Users can also use and edit their personal directory records using one-X Portal for IP Office. Note that using one-X Portal for IP Office, users can have more personal directory records, with excess records stored by the one-X Portal server.

### Related links

[Configure User Settings](#) on page 662

## Account Code Configuration

### Forcing Account Code Entry for Specific Numbers

Account code can be set as being required for any dialing that matches a particular short code. This is done by ticking the Force Account Code option found in the short code settings. Note that the account code request happens when the short code match occurs. Potentially this can be in

the middle of dialing the external number, therefore the use of **X** wildcards in the short code to ensure full number dialing is recommended.

### Entering Account Codes

The method for entering account codes depends on the type of phone being used. Refer to the relevant telephone User's Guide for details.

#### Account Code Button:

The Account Code Entry action (**User | Button Programming | Emulation | Account Code Entry**) and Set Account Code action (**User | Button Programming | Advanced | Set | Set Account Code**) can be assigned to a programmable button on some phones. They both operate the same. The button can be preset with a specific account code or left blank to request account code entry when pressed. The button can then be used to specify an account code before a call or during a call.

#### Setting an Account Code using Short Codes:

The **Set Account Code** feature allows short codes to be created that specify an account code before making a call.

#### Show Account Code Setting :

This setting on the **System | Telephony | Telephony** tab controls the display and listing of system account codes.

When on and entering account codes through a phone, the account code digits are shown while being dialed.

When off and entering account codes through a phone, the account code digits are replaced by **s** characters on the display.

### Server Edition Account Code Management

Accounts codes configured on Server Edition are shared by all systems in the network.

#### Related links

[Configure User Settings](#) on page 662

[Setting a User to Forced Account Code](#) on page 684

---

## Setting a User to Forced Account Code

### Procedure

1. Receive the system configuration if one is not opened.
2. In the left-hand panel, click **User**. The list of existing user is shown in the right-hand panel.
3. Double-click the required user.
4. Select the **Telephony** tab.
5. Tick the Force Account Code option.
6. Click **OK**.
7. Merge the configuration.

**Related links**

[Account Code Configuration](#) on page 683

---

## Coverage Groups

For users with a **Coverage Group** selected, coverage group operation is applied to all external calls that are targeted to the user.

For external calls:

In scenarios where an external call would normally have gone to voicemail, it instead continues ringing and also starts alerting the members of the coverage group.

- The follow me settings of Coverage Group members are used, the forwarding settings are not.
- If the user is not available, for example if they have logged off or set to do not disturb, coverage group operation is applied immediately.
- If the user is configured for call forward on busy, coverage operation is applied to the user's calls forwarded to the forward on busy destination.

Coverage group operation is not applied to the following types of call:

Hunt group calls.

Recall calls such as transfer return, hold recall, park recall, automatic callback.

The Coverage Group is set through the user's User | Telephony | Supervisor Settings or through their associated User Rights | Telephony | Supervisor Settings. The only group settings used are:

- The list of group members. They are treated as a collective group regardless of the group's configuration.
- If the group has **Night Server Fallback Group** and or **Out of Service Fallback Group** set, the members of those groups are used if the coverage group is set to night service mode or out of service mode respectively.

**Related links**

[Configure User Settings](#) on page 662

---

## DND, Follow Me and Forwarding

This section contains topics looking at how users can have their calls automatically redirected. As illustrated, there is an order of priority in which the redirect methods are used.

## Configure User Settings

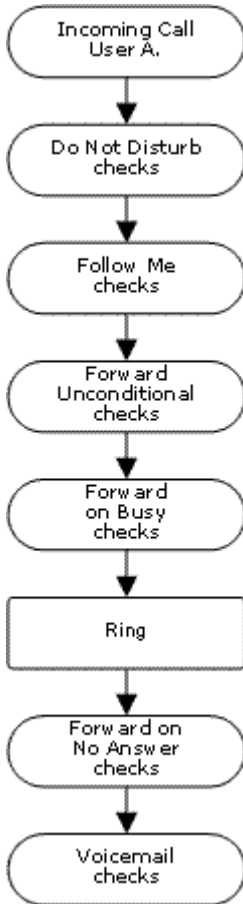

### Redirect priority

1. **Do Not Disturb (DND)** Redirect all calls to voicemail if available, otherwise return busy tone. DND overrides all the redirect method below unless the calling number is in the user's DND Exception Numbers List.
2. **Follow Me** Redirect all calls to another extension that the users is temporarily sharing. Follow Me overrides Forward Unconditional. The Follow Me destination is busy or does not answer, the user's Forward on Busy or Forward on No Answer options can be used if set.
3. **Forward Unconditional** Redirect the user's external calls to another number. That number can be any number the user can normally dial including external numbers. Forwarding of hunt group and internal calls is optional. Forward Unconditional overrides Forward on Busy and Forward on No Answer.  
  
If the destination is an internal user on the same system, they are able to transfer calls back to the user, overriding the Forward Unconditional.
4. **Forward on Busy** Redirects the user's external calls when the system sees the user as being busy. Uses the same number as Forward Unconditional unless a separate Forward on Busy Number is set. Forwarding internal calls is optional. Forward on Busy overrides Forward on No Answer.
5. **Forward on No Answer** Redirects the user's external calls when they ring for longer than the user's No Answer Time. Uses the same number as Forward Unconditional unless a separate Forward on Busy Number is set. Forwarding internal calls is optional.

**Retrieving Externally Forwarded Calls:**

Where a call is forwarded to an external destination and receives busy or is not answered within the forwarding user's **No Answer Time**, the system will attempt to retrieve the call. If forwarded on a trunk that does not indicate its state the call is assumed to have been answered, for example analog loop start trunks.

**Off-Switch Forwarding Restrictions:**

User forwarding is subject to the same restrictions as transferring calls. To bar a user from forwarding calls to an external number, the **Inhibit Off-Switch Forward/Transfers (User | Telephony | Supervisor Settings)** option. To bar all users from forwarding calls to external numbers the Inhibit **Off-Switch Forward/Transfers** option can be used.

When transferring a call to another extension that has forwarding enabled, the type of call being transferred is used. For example, if transferring an external call, if the transfer target has forwarding of external calls enabled then the forward is used.

**Block Forwarding:**

The Block Forwarding setting is used for enforcing predictable call routing, where the call should always go to the same destination. This setting was implemented for contact center applications.

Block Forwarding can be set for a user on the **User | Forwarding** page or as a user rights setting on the **User Rights | Forwarding** page.

**Related links**

- [Configure User Settings](#) on page 662
- [Do Not Disturb \(DND\)](#) on page 687
- [Follow Me](#) on page 689
- [Forward Unconditional](#) on page 691
- [Forward on Busy](#) on page 693
- [Forward on No Answer](#) on page 695
- [Determining a User's Busy Status](#) on page 697
- [Chaining](#) on page 698

---

**Do Not Disturb (DND)**

**Summary:** Redirect all calls to busy tone or to voicemail if available except those in your DND exceptions list.

Do Not Disturb (DND) is intended for use when the user is present but for some reason does not want to be interrupted. Instead calls are sent to voicemail if available, otherwise they receive busy tone.

**Exceptions** Specific numbers can be added to the user's Do Not Disturb Exception List. Calls from those numbers override DND. N and X wildcards can be used at the end of exception numbers to match a range of numbers. For external numbers, this uses the incoming caller line ID (ICLID) received with the call.

**Priority** Enabling DND overrides any Follow Me or forwarding set for the user, except for calls in the user's Do Not Disturb Exception List.

**Phone** When enabled, the phone can still be used to make calls. An **N** is displayed on many Avaya phones. When a user has do not disturb in use, their normal extension will give alternate dialtone when off hook.

**Applied to**

Call Types Blocked		Call Treatment
<b>Internal</b>	✓	Voicemail if available, otherwise busy tone.
<b>External</b>	✓	Voicemail if available, otherwise busy tone.
<b>Hunt Group</b>	✓	Call not presented (DND exceptions are not used).
<b>Page</b>	✓	Call not presented.
<b>Follow Me</b>	✗	Rings.
<b>Forwarded</b>	✓	Busy.
<b>VM Ringback</b>	✗	Rings
<b>Automatic Callback</b>	✗	Rings
<b>Transfer Return</b>	✗	Rings.
<b>Hold Return</b>	✗	Rings.
<b>Park Return</b>	✗	Rings.
<b>Twinning</b>	✓	Voicemail if available, otherwise busy tone.

Do Not Disturb and Twinning

**Mobile Twinning** Selecting DND disables mobile twinning.

**Internal Twinning**

- Logging out or setting do not disturb at the primary stops twinned calls alerting at the secondary also.
- Logging out or setting do not disturb at the secondary only affects the secondary.

**Do Not Disturb Exceptions List** For both types of twinning, when DND is selected, calls from numbers entered in the user's Do Not Disturb Exception List are presented to both the primary and secondary phones.

Do Not Disturb Controls

Do Not Disturb	
<b>Manager</b>	A user's DND settings can be viewed and changed through the User   DND tab within the system configuration settings.

*Table continues...*



<b>Controls</b>	The following short code features/button programming actions can be used:
<b>Voicemail</b>	If voicemail is available, it is used instead of busy tone for callers not in the users exceptions list.  For Voicemail Pro, the Play Configuration Menu action can be used to let callers switch DND on or off.
<b>SoftConsole</b>	A SoftConsole user can view and edit a user's DND settings except exception numbers. Through the directory, select the required user. Their current status including DND is shown. Double-click on the details to adjust DND on or off.

Feature/Action	Short Code	Default	Button
Do Not Disturb On	✓	*08	✓ - Toggles.
Do Not Disturb Off	✓	*09	✓
Do Not Disturb Exception Add	✓	*10*N#	✓
Do Not Disturb Exception Delete	✓	*11*N#	✓
Cancel All Forwarding	✓	*00	✓

### Related links

[DND, Follow Me and Forwarding](#) on page 685

---

## Follow Me

**Summary:** Have your calls redirected to another user's extension, but use your coverage, forwarding and voicemail settings if the call receives busy tone or is not answered.

Follow Me is intended for use when a user is present to answer calls but for some reason is working at another extension such as temporarily sitting at a colleague's desk or in another office or meeting room. Typically you would use Follow Me if you don't have a Hot Desking log in code or if you don't want to interrupt your colleague from also receiving their own calls, ie. multiple users at one phone.

**Priority** Follow Me is overridden by DND except for callers in the user's DND Exception Numbers List. Follow Me overrides Forward Unconditional but can be followed by the user's Forward on Busy or Forward on No Answer based on the status of the Follow Me destination.

**Destination** The destination must be an internal user extension number. It cannot be a hunt group extension number or an external number.

**Duration** The Follow Me user's no answer timeout is used. If this expires, the call either follows their Forward on No Answer setting if applicable, or goes to voicemail if available. Otherwise the call continues to ring at the destination.

**Phone** When enabled, the phone can still be used to make calls. When a user has follow me in use, their normal extension will give alternate dialtone when off hook.

**Exceptions**

- The Follow Me destination extension can make and transfer calls to the follow me source.
- The call coverage settings of the user are applied to their Follow Me calls. The call coverage settings of the destination are not applied to Follow Me calls it receives.

**Calls Forwarded**

Call Types Redirected		
<b>Internal</b>	✓	Redirected.
<b>External</b>	✓	Redirected.
<b>Hunt Group</b>	✓	Redirected*.
<b>Page</b>	✓	Redirected.
<b>Follow Me</b>	✗	Not redirected.
<b>Forwarded</b>	✓	Redirected.
<b>VM Ringback</b>	✗	Not redirected.
<b>Automatic Callback</b>	✗	Not redirected.
<b>Transfer Return</b>	✗	Not redirected.
<b>Hold Return</b>	✗	Not redirected.
<b>Park Return</b>	✗	Not redirected.

\*Except calls for "Longest Waiting" type hunt groups.

**Follow Me Controls**

Follow Me	
<b>Manager</b>	A user's Follow Me settings can be viewed and changed through the User   Forwarding tab within the system configuration settings. Note that on this tab, entering a Follow Me Number also enables Follow Me.
<b>Controls</b>	The following short code features/button programming actions can be used:

*Table continues...*

<b>Voicemail</b>	For calls initially targeted to the user but then redirected, when voicemail is invoked the mailbox of the user is used and not the mailbox of the destination.  For Voicemail Pro, the Play Configuration Menu action can be used to let callers alter or set their current Follow Me destination.
<b>SoftConsole</b>	A SoftConsole user can view and edit a user's Follow Me settings. Through the directory, select the required user. Their current status including Follow Me is shown. Double-click on the details and select Forwarding to alter their forwarding settings including Follow Me.

Feature/Action	Short Code	Default	Button
Follow Me Here	✓	*12*N#	✓
Follow Me Here Cancel	✓	*13*N#	✓
Follow Me To	✓	*14*N#	✓
Cancel All Forwarding	✓	*00	✓

### Related links

[DND, Follow Me and Forwarding](#) on page 685

## Forward Unconditional

**Summary:** Have your calls redirected immediately to another number including any external number that you can dial.

**Priority** This function is overridden by DND and or Follow Me if applied. **Forward Unconditional** overrides **Forward on Busy**.

**Destination** The destination can be any number that the user can dial. If external and Inhibit Off-Switch Transfers is applied, the caller is directed to voicemail if available, otherwise they receive busy tone. If the destination is an internal user on the same system, they are able to transfer calls back to the user, overriding the Forward Unconditional.

**Duration** After being forwarded for the user's no answer time, if still unanswered, the system can apply additional options. It does this if the user has forward on no answer set for the call type or if the user has voicemail enabled.

- If the user has forward on no answer set for the call type, the call is recalled and then forwarded to the forward on no answer destination.
- If the user has voicemail enabled, the call is redirected to voicemail.
- If the user has both options set, the call is recalled and then forwarded to the forward on no answer destination for their no answer time and then if still unanswered, redirected to voicemail.

- If the user has neither option set, the call remains redirected by the forward unconditional settings.

Note that for calls redirected via external trunks, detecting if the call is still unanswered requires call progress indication. For example, analog lines do not provide call progress signalling and therefore calls forwarded via an analog lines are treated as answered and not recalled.

**Phone** When enabled, the phone can still be used to make calls. An **D** is displayed on DS phones. When a user has forward unconditional in use, their normal extension will give alternate dialtone when off hook.

**Calls Forwarded** Once a call has been forwarded to an internal destination, it will ignore any further **Forward No Answer** or **Forward on Busy** settings of the destination but may follow additional **Forward Unconditional** settings unless that creates a loop.

Call Types Forwarded		
<b>Internal</b>	✓	Optional.
<b>External</b>	✓	Forwarded.
<b>Hunt Group</b>	✓	Optional.*
<b>Page</b>	✗	Not presented.
<b>Follow Me</b>	✗	Rings.
<b>Forwarded</b>	✓	Forwarded.
<b>VM Ringback</b>	✗	Rings.
<b>Automatic Callback</b>	✗	Rings.
<b>Transfer Return</b>	✗	Rings.
<b>Hold Return</b>	✗	Ring/hold cycle.
<b>Park Return</b>	✗	Rings.

\*Optional only for calls targeting sequential and rotary type groups. Includes internal call to a hunt group regardless of the forward internal setting.

**To Voicemail:** Default = Off. If selected and forward unconditional is enabled, calls are forwarded to the user's voicemail mailbox. The **Forward Number** and **Forward Hunt Group Calls** settings are not used. This option is not available if the system's **Voicemail Type** is set to **None**. 1400, 1600, 9500 and 9600 Series phone users can select this setting through the phone menu. Note that if the user disables forward unconditional the **To Voicemail** setting is cleared.

Forward Unconditional Controls

Forward Unconditional	
<b>Manager</b>	A user's forwarding settings can be viewed and changed through the User   Forwarding tab within the system configuration settings.
<b>Controls</b>	The following short code features/button programming actions can be used:

*Table continues...*

<b>Voicemail</b>	<p>For calls initially targeted to the user but then redirected, when voicemail is invoked the mailbox of the user is used and not the mailbox of the destination.</p> <p>For Voicemail Pro, the Play Configuration Menu action can be used to let callers set their current forwarding destination and switch Forwarding Unconditional on/off.</p>
<b>SoftConsole</b>	A SoftConsole user can view and edit a user's forwarding settings. Through the directory, select the required user. Their current forwarding status is shown. Double-click on the details and select Forwarding to alter their forwarding settings.

Feature/Action	Short Code	Default	Button
Forward Number	✓	*07*N#	✓
Forward Unconditional On	✓	*01	✓ - Toggles.
Forward Unconditional Off	✓	*02	✓
Forward Hunt Group Calls On	✓	✗	✓ - Toggles.
Forward Hunt Group Calls Off	✓	✗	✓
Disable Internal Forwards	✓	✗	✗
Enable Internal Forwards	✓	✗	✗
Disable Internal Forwards Unconditional	✓	✗	✗
Enable Internal Forwards Unconditional	✓	✗	✗
Set No Answer Time	✓	✗	✓
Cancel All Forwarding	✓	*00	✓

**Related links**

[DND, Follow Me and Forwarding](#) on page 685

**Forward on Busy**

Summary: Have your calls redirected when you are busy to another number including any external number that you can dial.

The method by which the system determines if a user is 'busy' to calls depends on factors such as whether they have multiple calls appearance buttons or Call Waiting and or Busy on Held set. See Busy.

**Priority** This function is overridden by DND and or Forward Unconditional if applied. It can be applied after a Follow Me attempt. It overrides Forward on No Answer.

**Destination** The destination can be any number that the user can dial. The Forward Unconditional destination number is used unless a separate number Forward on Busy Number is set. If Inhibit Off-Switch Transfers is applied, the caller is directed to voicemail if available, otherwise they receive busy tone.

**Duration** The destination is rung using the forwarding user's No Answer Time. If this expires, the call goes to voicemail is available. Calls to an external destination sent on trunks that do not signal their state are assumed to have been answered, for example analog loop start trunks.

**Phone** Forward on Busy is not indicated and normal dial tone is used.

**Calls Forwarded** Once a call has been forwarded to an internal destination, it will ignore any further **Forward No Answer** or **Forward on Busy** settings but may follow additional **Forward Unconditional** settings.

Call Types Forwarded		
<b>Internal</b>	✓	Optional.
<b>External</b>	✓	Forwarded.
<b>Hunt Group</b>	✗	Not presented.
<b>Page</b>	✗	Not presented.
<b>Follow Me</b>	✗	Rings.
<b>Forwarded</b>	✓	Forwarded.
<b>VM Ringback</b>	✗	Rings.
<b>Automatic Callback</b>	✗	Rings.
<b>Transfer Return</b>	✗	Rings.
<b>Hold Return</b>	✗	Ring/hold cycle.
<b>Park Return</b>	✗	Rings.

Forward on Busy Controls

Forward on Busy	
<b>Software Level</b>	A user's forwarding settings can be viewed and changed through the User   Forwarding tab within the system configuration settings.
<b>Controls</b>	The following short code features/button programming actions can be used:

*Table continues...*

<b>Voicemail</b>	<p>For calls initially targeted to the user but then redirected, when voicemail is invoked the mailbox of the user is used and not the mailbox of the destination.</p> <p>For Voicemail Pro, the Play Configuration Menu action can be used to let callers set the forward destination.</p>
<b>SoftConsole</b>	A SoftConsole user can view and edit a user's forwarding settings. Through the directory, select the required user. Their current forwarding status is shown. Double-click on the details and select Forwarding to alter their forwarding settings.

Feature/Action	Short Code	Default	Button
Forward Number	✓	*07*N#	✓
Forward on Busy Number	✓	*57*N#	✓
Forward on Busy On	✓	*03	✓ - Toggles.
Forward on Busy Off	✓	*04	✓
Disable Internal Forwards	✓	✗	✗
Enable Internal Forwards	✓	✗	✗
Disable Internal Forwards Busy or No Answer	✓	✗	✗
Enable Internal Forwards Busy or No Answer	✓	✗	✗
Set No Answer Time	✓	✗	✓
Cancel All Forwarding	✓	*00	✓

### Related links

[DND, Follow Me and Forwarding](#) on page 685

---

## Forward on No Answer

Summary: Have your calls redirected another number if it rings without being answered.

**Priority** This function is overridden by DND and Forward on Busy if applied. It can be applied after a Follow Me attempt. Forward Unconditional overrides Forward on Busy and Forward on No Answer.

**Destination** The destination can be any number that the user can dial. The Forward Unconditional destination number is used unless a separate number Forward on Busy Number is set. If Inhibit Off-Switch Transfers is applied, the caller is directed to voicemail if available, otherwise they receive busy tone.

**Duration** The destination is rung using the forwarding user's No Answer Time. If this expires, the call goes to voicemail if available. Otherwise the call continues to ring at the destination. Calls to an external destination sent on trunks that do not signal their state are assumed to have been answered, for example analog loop start trunks.

**Phone** Forward on No Answer is not indicated and normal dial tone is used.

**Calls Forwarded** Once a call has been forwarded to an internal destination, it will ignore any further **Forward No Answer** or **Forward on Busy** settings but may follow additional **Forward Unconditional** settings.

Call Types Forwarded		
<b>Internal</b>	✓	Optional.
<b>External</b>	✓	Forwarded.
<b>Hunt Group</b>	✗	Not applicable.
<b>Page</b>	✗	Not applicable.
<b>Follow Me</b>	✗	Rings.
<b>Forwarded</b>	✓	Forwarded.
<b>VM Ringback</b>	✗	Rings.
<b>Automatic Callback</b>	✗	Rings.
<b>Transfer Return</b>	✗	Rings.
<b>Hold Return</b>	✗	Ring/hold cycle.
<b>Park Return</b>	✗	Rings.

Forward on No Answer Controls

Forward on No Answer	
<b>Manager</b>	A user's forwarding settings can be viewed and changed through the User   Forwarding tab within the system configuration settings.
<b>Controls</b>	The following short code features/button programming actions can be used:

*Table continues...*



<b>Voicemail</b>	<p>For calls initially targeted to the user but then redirected, when voicemail is invoked the mailbox of the user is used and not the mailbox of the destination.</p> <p>For Voicemail Pro, the Play Configuration Menu action can be used to let callers set the forward destination. It cannot however be used to enable Forward on Busy or set a separate Forward on Busy number.</p>
<b>SoftConsole</b>	A SoftConsole user can view and edit a user's forwarding settings. Through the directory, select the required user. Their current forwarding status is shown. Double-click on the details and select Forwarding to alter their forwarding settings.

Feature/Action	Short Code	Default	Button
Forward Number	✓	*07*N#	✓
Forward on Busy Number	✓	*57*N#	✓
Forward on No Answer On	✓	*05	✓ - Toggles.
Forward on No Answer Off	✓	*06	✓
Enable Internal Forwards	✓	✗	✗
Disable Internal Forwards	✓	✗	✗
Enable Internal Forwards Busy or No Answer	✓	✗	✗
Disable Internal Forwards Busy or No Answer	✓	✗	✗
Set No Answer Time	✓	✗	✓
Cancel All Forwarding	✓	*00	✓

### Related links

[DND, Follow Me and Forwarding](#) on page 685

---

## Determining a User's Busy Status

Various system features allow users to handle more than one call at a time. Therefore the term "busy" has different meanings. To other users it means whether the user is indicated as being busy. To the system it means whether the user is not able to receive any further calls. The latter is

used to trigger 'busy treatment', either using a user's **Forward on Busy** settings or redirecting calls to voicemail or just returning busy tone.

**Busy Indication - In Use** The user busy indication provided to programmable buttons and to user applications, is based on the monitored user's hook switch status. Whenever the user is off-hook, they will be indicated as being busy regardless of call waiting or call appearance settings.

**Busy to Further Calls** Whether a user can receive further calls is based on a number of factors as described below.

- **Logged In and Present** Is the user logged into an extension and is that extension physically connected to the system.
- **Busy on Held** If a user enables their Busy on Held setting, whenever they have a call on hold, they are no longer available to any further incoming calls.
- **Appearance Buttons** A user's call appearance buttons are used to receive incoming calls. Normally, whilst the user has any free call appearance buttons, they are available to receive further calls. Exceptions are:
  - **Reserve Last Appearance** Users with appearance buttons require a free call appearance button to initiate transfers or conferences. Therefore it is possible through the user's configuration settings to reserve their last call appearance button for outgoing calls only.
  - **Other Appearance Buttons** Calls may also be indicated on line, call coverage and bridged appearance buttons.

**Call Waiting** Users of phones without appearance buttons can use call waiting. This adds an audio tone, based on the system locale, when an additional call is waiting to be answered. Only one waiting call is supported, any further calls receive busy treatment.

**Hunt Group Calls** A user's availability to receive hunt group calls is subject to a range of other factors. See Member Availability.

## Related links

[DND, Follow Me and Forwarding](#) on page 685

---

## Chaining

Chaining is the process where a call forward to an internal user destination is further forwarded by that user's own forwarding settings.

**Follow Me Calls** Follow Me calls are not chained. They ignore the forwarding, Follow Me and Do Not Disturb settings of the Follow Me destination.

**Voicemail** If the call goes to voicemail, the mailbox of the initial call destination before forwarding is used.

**Looping** When a loop would be created by a forwarding chain, the last forward is not applied. For example the following are scenarios where A forwards to B, B forwards to C and C forwards to A. In each case the final forward is not used as the destination is already in the forwarding chain.

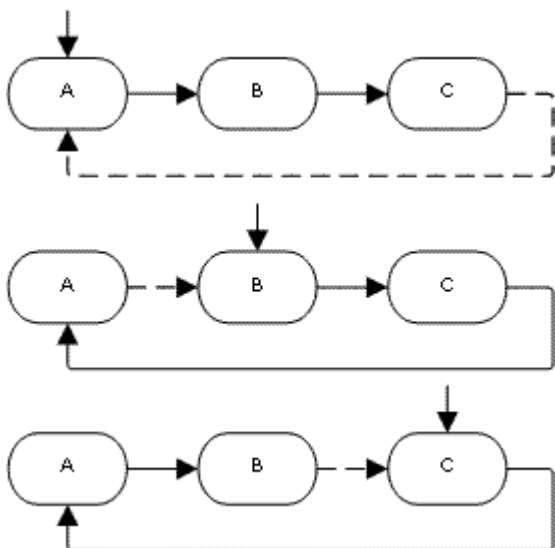

**Hunt Group Loop** If a user forwards a call to a hunt group of which they are a member, the group call is not presented to them but is presented to other members of the hunt group.

**Maximum Number of Forwards** A maximum of 10 forwarding hops are supported for any call.

**Calls Forwarded** Once a call has been forwarded to an internal destination, it will ignore any further **Forward No Answer** or **Forward on Busy** settings but may follow additional **Forward Unconditional** settings.

#### Related links

[DND, Follow Me and Forwarding](#) on page 685

---

## Hot Desking

Hot desking allows users to log in at another phone. Their incoming calls are rerouted to that phone and their user settings are applied to that phone. There are a number of setting and features which affect logging in and out of system phones.

In order to hot desk, a user must be assigned a Login Code (User | Telephony | Supervisor Settings) in the system configuration.

By default, each system extension has an **Base Extension** setting. This associates the extension with the user who has the matching **Extension** settings as being that extension's default associated user.

- By leaving the **Base Extension** setting for an extension blank, it is possible to have an extension with no default associated user. This is only supported for non-IP/CTI extensions. Extensions in this state use the settings of a special user named **NoUser**. On suitable phones the display may show **NoUser**.
- You can create users whose Extension directory number is not associated with any physical extension. These users must have a log in code in order to log in at a phone when they need

to make or receive calls. In this way the system can support more users than it has physical extensions.

When another user logs in at an extension, they take control of that phone. Any existing user, including the default associated user, is logged out that phone.

- Any user settings not applicable to the type of phone on which the user has logged in become inaccessible. For example some programmable button features will become inaccessible if the phone at which a user logs in does not have a sufficient number of programmable buttons.
- Note that settings that are stored by the phone rather than by the system remain with the phone and do not move when a user hot desks.

1400 Series, 1600 Series, 9500 Series, 9600 Series, M-Series and T-Series telephones all use the centralized call log and centralized personal directory features that move those settings with the user as they hot desk.

Other Avaya H.323 IP telephones can be configured to backup and restore user settings to a file server when a user hot desks between phones. The range of settings supported depends on the particular phone model. Refer to the IP Office H.323 IP Telephone Installation Manual.

For all other features and phone types, it must be assumed that any settings and data shown by the phone is stored by the phone and are still accessible after logging off.

When a user logs off or is logged out by someone else logging in, they are automatically logged back in at the extension for which they are the default associated user if no one else is logged in at that extension. However this does not happen for users set to **Forced Login** (User | Telephony | Supervisor Settings).

For each user, you can configure how long the extension at which they are logged in can remain idle before they are automatically logged out. This is done using the Login Idle Period option. This option should only be used in conjunction with Force Login.

Logged in users who are members of a hunt group can be automatically logged out if they do not answer hunt group calls presented to them. This is done by selecting **Logged Off** as the user's **Status on No Answer** (User | Telephony | Supervisor Settings) setting.

Calls to a logged out user are treated as if the user is busy until the user logs in.

Logging in and out at a phone can be done either using system short codes or programmable buttons.

- The default system short code for logging in, is **\*35\*N#** where the user replaces N with their extension number and then log in code separated by a \*. This uses the short code feature ExtnLogin. If the user dials just a log in code as N, it is checked against the user with the same extension number as the extension's base extension number.
- The default system short code for logging out is **\*36**. This uses the short code feature ExtLogout.
- The ExtnLogin and ExtnLogout features can be assigned to programmable buttons on suitable Avaya phones. The **ExtnLogin** button will then prompt the user to enter their details.

## Related links

[Configure User Settings](#) on page 662

[Remote Hot Desking](#) on page 701

[Call Center Agents](#) on page 702

[Hot Desking Examples](#) on page 702

[Automatic Log Out](#) on page 704

---

## Remote Hot Desking

The system supports hot desking between systems within a network.

In the descriptions below, the system on which the user is configured is termed their 'home' system, all other systems are 'remote' systems.

When a user logs in to a remote system:

- The user's incoming calls are rerouted to that system.
- The user's outgoing calls uses the settings of the remote system.
- The user's license privileges move with them, for example their user profile setting is retained. The host system does not need to be licensed for the user.
- The user's own settings are transferred. However, some settings may become unusable or may operate differently.
- User rights are not transferred to the remote system but the name of any user rights associated with the user are transferred. If user rights with the same name exist on the remote system, then they will be used. The same applies for user rights applied by time profiles, if time profiles with the same name exist on the remote system .
- Appearance buttons configured for users on the home system will no longer operate.
- Various other settings may either no longer work or may work differently depending on the configuration of the remote system at which the user has logged in.
- The rights granted to the user by their **Profile** settings are retained by the user. There is no requirement for the remote system to have the appropriate licenses for the **Profile**.

If the user's home system is disconnected while the user is remotely hot desked, the user will remain remotely hot desked. They can remain in that state unless the current host system is restarted. They retain their license privileges as if they were on their home system. Note however that when the user's home system is reconnected, the user may be automatically logged back onto that system.

**Break Out Dialing** In some scenarios a hot desking user logged in at a remote system will want to dial a number using the system short codes of another system. This can be done using either short codes with the **Break Out** feature or a programmable button set to **Break Out**. This feature can be used by any user within the multi-site network but is of most use to remote hot deskers.

## Related links

[Hot Desking](#) on page 699

## Call Center Agents

On systems with a call center application such as Compact Contact Center (CCC) or Compact Business Center (CBC), logging in and logging out is a key part of tracking and reporting on call center agents. It also controls call distribution as, until the agent logs in, their hunt group membership is seen as disabled.

For CCC, CBC and Delta Server, an agent is defined as being a user with a Login Code and set to Forced Login. Those users consume a CCC agent license.

### Related links

[Hot Desking](#) on page 699

---

## Hot Desking Examples

The following are example of different ways that the hot desking settings can be used.

### Related links

[Hot Desking](#) on page 699

## Scenario 1: Occasional Hot Desking

### About this task

In this scenario, a particular user, for this example extension 204, needs to occasionally work at other locations within the building.

### Procedure

1. A **Login Code** is added to the user's configuration settings, for this example **1234**.
2. The user can now log in when needed at any other phone by dialing **\*35\*204\*1234#**.

The phone's default associated user is logged out by this and their calls get busy treatment. User 204 is also logged out their normal phone and their calls now rerouted to the phone at which they have logged in.

3. When finished, the user can dial **\*36** to log out.
4. This logs the phone's normal default user back on.

Its also logs the hot desking user back on at their normal extension.

## Scenario 2: Regular Hot Desking

### About this task

This scenario is very similar to the one above. However, the user doesn't want to be automatically logged back in on their normal phone until they return to its location.

## Procedure

1. A **Login Code** is added to the user's configuration settings, for this example **1234**.
2. The Forced Login option is selected.
3. When the user logs out of the phone that they are currently using, they are no longer automatically logged in on their normal extension.

When they return to it they must dial **\*35\*204\*1234#** to log in.

4. Whilst not logged in anywhere, calls to the user receive busy treatment.

## Scenario 3: Full Hot Desking

### About this task

Similar to the scenarios above but this time the user doesn't have a regular phone extension that they use. In order to make and receive calls they must find a phone at which they can log in.

### Procedure

1. The user is given an Extension directory number that is not matched by the extension directory number setting of any existing extension.
2. They are also given a **Login Code** and a **Login Idle Period** is set, for this example 3600 seconds (an hour).  
**Forced Login** isn't required as the user has no default extension at which they might be automatically logged in by the system.
3. The user can now log in at any available phone when needed.
4. If at the end of the business day they forget to log out, the Login Idle Period will eventually log them off automatically.

## Scenario 4: Call Center Hot Desking

### About this task

In this scenario, the phone extensions have no default extension number. Several phones set like this might be used in a call center where the agents use whichever desk is available at the start of their shift. Alternatively a set of desks with such phones might be provided for staff that are normally on the road but occasionally return to the office and need a temporary desk area to complete paper work.

### Procedure

1. For the extensions, the Extension setting is left blank.  
This means that those phones will be associated with the NoUser user's settings and display **NOT LOGGED ON**.
2. The call center agents or road-warrior users are configured with Extension directory numbers that also don't match any existing physical extensions.

They are all given Login Code numbers.

3. The users can log in at any of the extensions when required.

When they log out or log in elsewhere, the extensions return to the NoUser setting.

---

## Automatic Log Out

Normally a user can either log themselves out or be logged out by another user logging in. The following methods can be used by the system to automatically log out a user, so long as that user has a **Login Code** and is set to **Forced Login**.

Note: A remote hot desking user whose home system can no longer be seen by the remote system at which they are logged in is automatically logged out after 24 hours.

### Idle Timeout:

The user **Login Idle Period (User | Telephony | Supervisor Settings)** can be used to automatically log out the user after a set period of phone inactivity. The period can be set between 1 to 99999 seconds and is based on call inactivity other than ringing calls.

### Unanswered Calls:

Users who are members of hunt groups are presented with hunt group calls when they are logged in and not already on a call. If the user is logged in but not actually present they will continue to be presented with hunt group calls. In this scenario it can be useful to log the user off.

- **For the hunt group** On the **Hunt Group | Hunt Group** tab, use the **Agent's Status on No Answer Applies to** setting to select which types of unanswered hunt group calls should change the user's status. The options are:
  - **None**
  - **Any Calls**
  - **External Inbound Calls Only**
- **For the user** The **Status on No Answer** setting (**User | Telephony | Supervisor Settings**) can be used. This sets what the user's status should be changed to if they do not answer a hunt group call. The options are:
  - **Logged In** If this option is selected, the user's status is not changed.
  - **Busy Wrap-Up** If this option is selected, the user's membership status of the hunt group triggering the action is changed to disabled. The user can still make and receive calls and will still continue to receive calls from other hunt groups to which they belong.
  - **Busy Not Available** If this option is selected, the user's status is changed to do not disturb. This is the equivalent of DND and will affect all calls to the user.
  - **Logged Off** If this option is selected, the user's status is changed to logged out. In that state the cannot make calls and cannot receive calls. Hunt group calls go to the next available agent and personal calls treat the user as being busy.



**Related links**

[Hot Desking](#) on page 699

---

## Group Operation

A group is a collection of users accessible through a single directory number. Calls to that group can be answered by any available member of the group. The order in which calls are presented can be adjusted by selecting different group types and adjusting the order in which group members are listed.

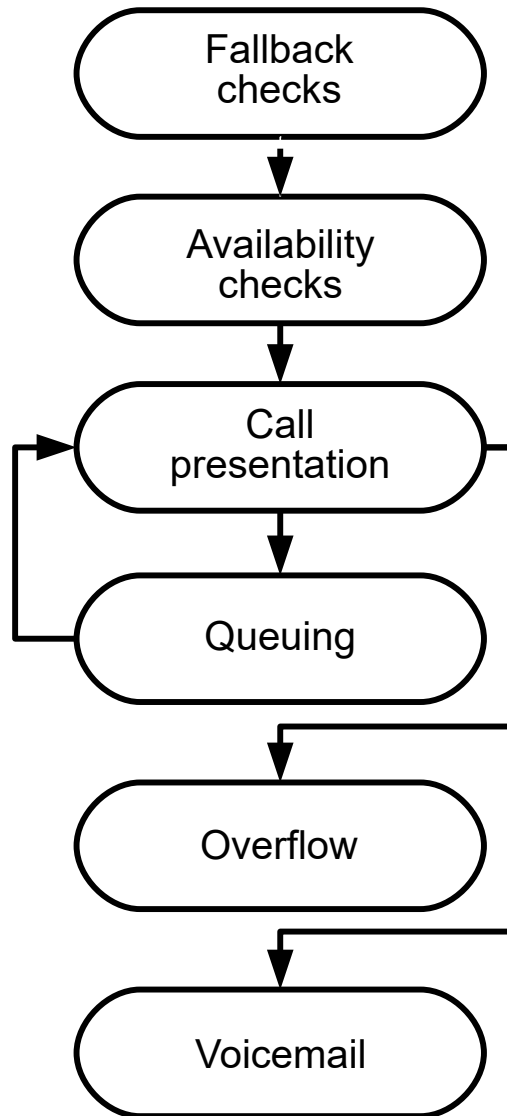

- **Call Presentation:** The order in which the available members of the group are used for call

presentation is selectable.

- **Availability:** There are a range of factors which control whether group calls are presented to a user in addition to that user being a member of the group.
- **Queuing:** This optional feature allows calls to be queued when the number of calls to be presented exceeds the number of available group members to which call can be presented.
- **Announcements:** On systems with a voicemail server (Voicemail Pro or Embedded Voicemail), announcements can be played to callers waiting to be answered. That includes calls that are ringing and calls that are queued.
- **Overflow:** This optional feature can be used to include additional agents from an overflow group or groups when a call is not answered.
- **Fallback:** A group can be taken out of operation manually or using a time profile. During fallback, calls can be redirected to a fallback group or sent to voicemail or just receive busy tone. Two types of fallback are supported; night service and out of service.
- **Voicemail:** Calls can be redirected to voicemail. The system allows selection of whether group calls remain in the group mailbox or are copied (broadcast) to the individual mailboxes of the group members. When messages are stored in the group's own mailbox, selection of who receives message waiting indication is possible.

## Group Editing

Changing the name of a group has the following effects:

- A new empty mailbox is created on voicemail with the new group name.
- Records in other groups' Overflow lists will be updated.
- Out-of-Service and Night-Service fallback references are updated.

Modifying the extension number of a group updates the following:

- Group buttons.
- Overflow, Out of Service Fallback and Night Service Fallback group records.
- Incoming call route records.

When a group is deleted, all references to the deleted group will be removed including:

- Records in Incoming call routing tables.
- Transfer target in internal auto-attendant.
- Overflow, Night-Service or Fallback-Service on other groups.
- DSS keys monitoring group status.

## Server Edition Group Management

Groups can be stored in the configuration of any system in the network. Groups created at the solution level on Manager and Web Manager are stored on the Primary Server. All groups can include users from anywhere in the network and are automatically advertised to and diallable on any of the systems in the network.

Groups configured on the Server Edition Primary by default fail over to the Server Edition Secondary. Groups configured on a Server Edition Expansion System can be configured to fail over to the Server Edition Primary, the Server Edition Secondary, or another Server Edition Expansion System.

## Groups in a Multi-Site Network

In a multi-site network, the extension numbers of users are automatically shared between systems and become diallable from other systems without any further programming.

The following features are available for groups.

### Advertised Groups:

Each group can be set as being 'advertised'. The group can then be dialed from other systems within the multi-site network. The groups extension number and name must be unique within the network. Non-advertised group numbers remain local only to system hosting the group.

### Distributed Groups:

Groups on a system can include users located on other systems within the network. Distributed groups are automatically advertised to other systems within the network. Note that distributed groups can only be edited on the system on which they were created.

### Related links

- [Configure User Settings](#) on page 662
- [Group Types](#) on page 708
- [Call Presentation](#) on page 709
- [Group Member Availability](#) on page 710
- [Example Hunt Group](#) on page 712
- [CBC/CCC Agents and Hunt Groups](#) on page 714

## Group Types

At its most basic, a group's settings consist of a group name, an extension number, a list of group members and a hunt type selection. It is the last two settings which determine the order in which incoming calls are presented to hunt group members.

The available group types are; Collective, Sequential, Rotary and Longest Waiting. These work are follows:

Collective Group (formerly Group Group)	
An incoming call is presented simultaneously to all the available group members.	
Sequential Group (formerly Hunt or Linear Group)	

*Table continues...*

<p>An incoming call is presented to the first available member in the list. If unanswered, it is presented to the next available member in the list.</p> <p>The next incoming call uses the same order. It is presented to the available members starting again from the top of the list.</p>	
<p>Rotary Hunt Type (formerly Circular Group)</p>	
<p>Longest Waiting Hunt Type (formerly Idle or Most Idle)</p> <p>This hunt type does not present calls to hunt group members in the order that they are listed. It presents calls using the order of how long the available hunt group members have been idle.</p> <p>An incoming call is first presented to the available member who has been idle the longest. If unanswered it is presented to the next longest idle member.</p> <p>Release 4.2+: Where hunt group calls are being presented to a twinned extension, the longest waiting status of the user can be reset by calls answered at either their master or twinned extension.</p>	

## Related links

[Group Operation](#) on page 705

## Call Presentation

**Summary:** Calls are presented to each available hunt group member in turn. If having been presented to all the available members, none answers, the call is redirected to voicemail if available, otherwise it continues to be presented to the next available member.

In addition to the summary, options exist to have calls queued or to have calls also presented to agents in an overflow group or groups.

**First and Next Available Members** The first available member to which a call is presented and the order of the next available members to which a call is presented are determined by the hunt group's Hunt Type setting.

**Additional Calls** When additional calls are waiting to be presented, additional available hunt group members are alerted using the hunt group type. When any member answers a call it will be the first waiting call that is answered.

**No Available Members** If the number of incoming calls exceeds the number of available members to which calls can be presented, the following actions are usable in order of precedence.

**Queuing** If queuing has been enabled for the hunt, it is applied to the excess calls up to the limits specified for the number of queued calls or length of time queued.

**Voicemail** If voicemail has been enabled for the hunt group, excess calls are directed to voicemail.

**Busy Tone** Busy tone is returned to the excess calls (except analog and T1 CAS calls which remain queued).

**No Answer Time** This value is used to determine how long a call should ring at a hunt group member before being presented to the next available hunt group member. The **System | Telephony | Telephony | No Answer Time** setting is used unless a specific **Hunt | Hunt Group | No Answer Time** is set.

**Voicemail** If voicemail is being used, if having been presented to all the available group members the call is still not answered then it goes to voicemail.

The call will also go to voicemail when the hunt group's **Voicemail Answer Time** is exceeded. the mailbox of the originally targeted hunt group is used even if the call has overflowed or gone to a night server hunt group.

**Calls Not Being Answered Quick Enough - Overflow** In addition to ringing at each available member for the No Answer Time, a separate **Overflow Time** can be set. When a calls total ring time against the group exceeds this, the call can be redirected to an overflow group or groups.

**No Available Member Answers** If a call has been presented unanswered to all the available members, either of two actions can be applied. If voicemail is available, the call is redirected to voicemail. If otherwise, the call will continue being presented to hunt group members until answered or, if set, overflow is used.

**Call Waiting** For hunt groups using the Group hunt type, call waiting can be used.

#### Related links

[Group Operation](#) on page 705

---

## Group Member Availability

**Summary:** Details when a hunt group member is seen as being available to be presented a hunt group call.

The Hunt Group settings within Manager list those users who are members of the hunt group and therefore may receive calls directed to that hunt group. However there are a range of factors that can affect whether a particular hunt group member is available to take hunt group calls at any time.

**Existing Connected Call** Users with an existing connected call are not available to further hunt group calls. This is regardless of the type of connected call, whether the user has available call appearance buttons or is using call waiting.

**Hunt Group Call Waiting** For Collective hunt groups call waiting can be enabled using the **Ring Type** of **Collective Call Waiting**.

**Logged In/Logged Out** The system allows user's to log in and out extensions, a process known as 'hot desking'. Whilst a user is logged out they are not available to receive hunt group calls.

Mobile Twinning users with both **Hunt group calls eligible for mobile twinning** and **Twin when logged out** selected will still receive hunt group calls unless they switch off twinning.

**Membership Enabled/Disabled** The system provides controls to temporarily disable a users' membership of a hunt group. Whilst disabled, the user is not available to receive calls directed to that hunt group.

**Do Not Disturb** This function is used by users to indicate that they do not want to receive any calls. This includes hunt group calls. In call center environments this state is also known as 'Busy Not Available'. See Do Not Disturb.

**Busy on Held** When a user has a held call, they can receive other calls including hunt group calls. The Busy on Held settings can be used to indicate that the user is not available to further calls when they have a held call.

**Forward Unconditional** Users set to Forward Unconditional are by default not available to hunt group calls. The system allows the forwarding of hunt group calls to be selected as an option.

**Idle /Off Hook** The hunt group member must be idle in order to receive hunt group call ringing.

**No Available Members** If queuing has been enabled, calls will be queued. If queuing has not been enabled, calls will go to the overflow group if set, even if the overflow time is not set or is set to 0. If queuing is not enabled and no overflow is set, calls will go to voicemail. If voicemail is not available, external calls go to the incoming call routes fallback destination while internal calls receive busy indication.

Hunt Group Member Availability Settings	
<b>Manager</b>	Forwarding and do not disturb controls for a user are found on the User   Forwarding and User   DND tabs.  Enabling and disabling a users hunt group membership is done by ticking or unticking the user entry in the hunt group's extensions list on the Hunt Group   Hunt Group tab.
<b>Controls</b>	The following short code features/button programming actions can be used:
<b>SoftConsole</b>	A SoftConsole user can view and edit a user's settings. Through the directory, select the required user. Their current status including DND, Logged In and hunt group membership states are shown and can be changed. Forwarding settings can be accessed by then selecting Forwarding.

Feature/Action	Short Code	Default	Button
Hunt Group Enable	✓	✗	✓HGE na - Toggles.
Hunt Group Disable	✓	✗	✓HGDis
Forward Hunt Group On	✓	✓-*50	✓FwDH+ - Toggles

*Table continues...*

Feature/Action	Short Code	Default	Button
Forward Hunt Group Off	✓	✓-*51	✓FwDH-
Busy on Held	✓	✗	✓BusyH
Do Not Disturb On	✓	✓-*08	✓DNDOOn - Toggles
Do Not Disturb Off	✓	✓-*09	✓DNDOF
Extn Login	✓	✓-*35*N#	✓Login
Extn Logout	✓	✓-*36	✓Logof

**Related links**

[Group Operation](#) on page 705

---

## Example Hunt Group

The follow are simple examples of how a department might use the facilities of a hunt group.

### 1. Basic Hunt Group

<b>Scenario</b>	The Sales department want all sales related calls to be presented first to Jane, then Peter and finally Anne.
<b>Actions</b>	<ol style="list-style-type: none"> <li>1. Create a hunt group named Sales and assign it an extension number.</li> <li>2. Set the <b>Hunt Type</b> to <b>Sequential</b>.</li> <li>3. Add Jane, Peter and Ann to the <b>User L</b> ist in that order.</li> <li>4. Turn off queuing on the Queuing tab and voicemail on the Voicemail tab.</li> <li>5. Route relevant calls to the Sales group by selecting it as the destination in the appropriate Incoming Call Routes.</li> </ol>
<b>Results</b>	Any call received by the Sales hunt group is first presented to Jane if she is available. If Jane is not available or does not answer within 15 seconds the call is presented to Peter. If Peter is not available or does not answer within 15 seconds the call goes Anne. Since voicemail is not on, the call will continue to be presented around the group members in that order until it is answered or the callers hangs up.

### 2. Adding Voicemail Support



<b>Scenario</b>	A voicemail server has now been added to the system. The Sales department wants to use it to take messages from unanswered callers. When messages are left, they want Jane to receive message waiting indication.
<b>Actions</b>	<ol style="list-style-type: none"> <li>1. Open the Sales hunt group settings and select <b>Voicemail On</b> on the Voicemail tab.</li> <li>2. Select the User settings for Jane. On the <b>Source Numbers</b> tab, add the entry <b>HSales</b>.</li> </ol>
<b>Results</b>	Once a call to the Sales group has been presented to all the available members, if it is still unanswered then the call will be redirected to the group's voicemail mailbox to leave a message. When a message has been left, the message waiting indication lamp on Jane's phone is lit.

### 3. Using the Queuing Facility

<b>Scenario</b>	The Sales department now wants calls queued when no one is available to answer. However if the number of queued calls exceeds 3 they then want any further callers directed to voicemail.
<b>Actions</b>	<ol style="list-style-type: none"> <li>1. Open the Sales hunt group settings and select <b>Queuing On</b> on the <b>Queuing</b> tab.</li> <li>2. Set the <b>Queue Limit</b> to <b>3</b>.</li> </ol>
<b>Results</b>	When the Sales group are all on calls or ringing, any further calls to the group are queued and receive queuing announcements from the voicemail server. When the number of queued calls exceeds 3, any further calls are routed to the group's voicemail mailbox.

### 4. Using Out of Service Fallback

<b>Scenario</b>	During team meetings, the Sales department want their calls redirected to another group, for this example Support.
<b>Actions</b>	<ol style="list-style-type: none"> <li>1. Open the Sales hunt group settings and select the <b>Fallback</b> tab. In the <b>Out of Service Fallback Group</b> field select the <b>Support</b> group.</li> <li>2. Create a system short code <b>*88/Set Hunt Group Out of Service/300</b>.</li> <li>3. Create a system short code <b>*89/Clear Hunt Group Out of Service/300</b>.</li> </ol>

*Table continues...*

<b>Results</b>	Prior to team meetings, dialing *88 puts the Sales group into out of service mode. Its calls are then redirected to the Support group. Following the meeting, dialing *89 puts the Sales group back In Service.
----------------	-----------------------------------------------------------------------------------------------------------------------------------------------------------------------------------------------------------------

5. Using a Night Service Time Profile

<b>Scenario</b>	Outside their normal business hours, the Sales department want their group calls automatically sent to voicemail. This can be done using a time profile and leaving the Night Service Fallback Group setting blank.
<b>Actions</b>	<ol style="list-style-type: none"> <li>1. Create a Time Profile called <b>Sales Hours</b> and in it enter the times during which the Sales department are normally available.</li> <li>2. Open the Sales hunt group settings and select the <b>Fallback</b> tab.</li> <li>3. In the <b>Time Profile</b> field select <b>Sales Hours</b>.</li> </ol>
<b>Results</b>	Outside the normal business hours set in the time profile, the Sales hunt group is automatically put into Night Service mode. Since no Night Service Fallback Group has been set, calls are redirected to voicemail.

**Related links**

[Group Operation](#) on page 705

## CBC/CCC Agents and Hunt Groups

The use of and reporting on hunt groups is a key feature of call center operation. For IP Office, reporting is provided through the Compact Business Center (CBC) or Compact Contact Center (CCC) applications.

In order for these applications to provide hunt group and hunt group user (agent) reports, the following rules apply:

- The hunt group names must be restricted to a maximum of 12 characters.
- The hunt group and user extension numbers should be a maximum of 4 digits.
- Hunt group members should be given a Login Code and set to Force Login.
- The agent state Busy Not Available is equivalent to Do Not Disturb. The agent state Busy Wrap Up is equivalent to hunt group disable.

**Related links**

[Group Operation](#) on page 705

---

## Malicious Call Tracing (MCID)

MCID (Malicious Caller ID) is an ISDN feature. It is supported on BRI and PRI trunks to ISDN service provider who provide MCID.

When used, it instructs the ISDN exchange to perform a call trace on the user's current call and to keep a record of the call trace at the exchange for the legal authorities. Trace information is not provided to or displayed by the system or system phones.

The use of MCID is subject to local and national legal requirements that will vary. The feature may also not be enabled until specifically requested from the service provider. You should consult with your ISDN service provider and with appropriate legal authorities before attempting to use MCID.

### **Note:**

Currently, in Server Edition network, MCID is only supported for users using an MCID button and registered on the same IP500 V2 Expansion system as the MCID trunks.

### **Activating MCID**

1. **Liaise with the ISDN Service Provider** MCID should not be used without first confirming its usage with the ISDN service provider.
2. **Enabling MCID Call Tracing on a Line** BRI and PRI lines include a **Support Call Tracing Option** which by default is off.
3. **Enabling MCID Call Tracing for a User** Each user has a **Can Trace Calls (User | Telephony | Supervisor Settings)** option. This option is off by default.
4. **Providing an Active MCID Control** The user needs to be provided with a mechanism to trigger the MCID call trace at the exchange. This can be done using either a short code or a programmable button.
  - **MCID Activate Button** The action **MCID Activate (Advanced | Miscellaneous | MCID Activate)** can be assigned to a programmable buttons. It allows a malicious call trace to be triggered during a call.
  - **MCID Activate Short Codes** The feature **MCID Activate** can be used to create a short code to triggering a malicious call trace.

### **Related links**

[Configure User Settings](#) on page 662

---

## Message Waiting Indication

Message waiting indication (MWI) or a message lamp is supported for a wide variety of phones. It is used to provide the user with indication of when their voicemail mailbox contains new messages. It can also be configured to provide them with indication when selected hunt group mailboxes contain new messages.

Avaya digital and IP phones all have in-built message waiting lamps. Also for all phone users, the one-X Portal for IP Office application provides message waiting indication.

**Related links**

[Configure User Settings](#) on page 662

[Message Waiting Indication for Analog Phones](#) on page 716

[Message Waiting Indication for Analog Trunks](#) on page 717

## Message Waiting Indication for Analog Phones

For analog phones, the system supports a variety of analog message waiting indication (MWI) methods. The method used for an individual analog extension is set for the **Extn | Analog | Message Waiting Lamp Indication Type** field. Those methods are

- **101V**
- **51V Stepped**
- **81V**
- **Bellcore FSK**
- **Line Reversal A**
- **Line Reversal B**
- **None**
- **On**

The 101V method is only supported when using a Phone V2 expansion module.

81V is typically used in European countries. 51V Stepped is used in most other countries. However the actual method used for a particular model of analog phone should be confirmed with the phone manufacturer's documentation.

The **Message Waiting Lamp Indication Type** field also provides options for **None** (no MWI operation) and **On**. **On** selects a default message waiting indication method based on the system locale.

'On' Method	Locale
<b>81V</b>	Belgium, Denmark, Finland, France, Germany, Greece, Hungary, Iceland, Italy, Netherlands, Norway, Poland, Portugal, Russia, Saudi Arabia, Sweden, Switzerland, United Kingdom.
<b>51V Stepped</b>	Argentina, Australia, Brazil, Canada, Chile, China, Colombia, Japan, Korea, Mexico, New Zealand, Peru, South Africa, Spain, United States.

For the United Kingdom system locale (eng), the default Caller Display Type (UK) allows updates of an analog phone's ICLID display whilst the phone is idle. The system uses this facilities to display the number of new messages and total number of messages in the users own mailbox. This feature is not supported with other Caller Display Types.

## Hunt Group Message Waiting Indication

By default no message waiting indication is provided for hunt group voicemail mailboxes. Message waiting indication can be configured by adding an **H** entry followed by the hunt groups name to the Source Numbers tab of the user requiring message waiting indication for that hunt group. For example, for the hunt group Sales, add **HSales**. Hunt group message waiting indication does not require the user to be a member of the hunt group.

### Related links

[Message Waiting Indication](#) on page 715

---

## Message Waiting Indication for Analog Trunks

IP Office can provide a MWI for analog trunks from the PSTN network that terminate on an ATM4U-V2 card. Multiple users can be configured to receive a MWI from a single analog line. Users can receive an MWI from multiple lines. Configuring a user for MWI includes configuration of a button for automatically dialing the message center.

Note the following conditions.

- Only supported for analog trunks terminating on the ATM4U-V2 card.
- When Analog Trunk MWI is selected as the Voicemail Type, no other voicemail system is active. As a result, hunt group queue announcements are not supported, since they require Embedded Voice Mail or Voicemail Pro.
- All analog trunks configured for MWI must use the same message center number. Multiple message centers are not supported.
- Not supported in One-X Portal.
- No TAPI is provided for analog trunk MWI status.
- Not supported across multiple IP Office systems. If the analog line is on a different node than the user's phone, that phone cannot receive an MWI for the line.
- Mobile twinning is not supported. Analog trunk MWI is displayed only on the master set.
- Internal twinning is not supported automatically. However, the twinned set can be configured to receive the same analog trunk MWI as the master set.

### Configuring MWI for an Analog Trunk

1. Go to **System | Voicemail**. In the **Voicemail** field, select **Analog Trunk MWI**.
2. In the **Destination** field, enter the message center telephone number.
3. Select the **Line** you want to configure for Analog MWI, and then select the **Analog Options** tab.
4. In the **MWI Standard field**, select **Bellcore FSK**.
5. Select the **User** you want to configure for MWI and then select the **Button Programming** tab.
6. Select the button you want to configure and then click **Edit**.
7. In the **Action** field click the browse (...) button and select **Advanced > Voicemail > Monitor Analog Trunk MWI**.

8. In the **Action Data** field, enter the line appearance ID of the analog line.

#### Related links

[Message Waiting Indication](#) on page 715

---

## Mobile Call Control

Mobile call control is only supported on digital trunks, including SIP trunks. It allows a user receiving a call on their twinned device to access system dial tone and then perform dialing action including making calls and activating short codes.

After answering a twinned call, the Mobile Call Control user can dial \*\* (within 1 second of each other) to place that call on hold and instead get dial tone from the system. Any dialing is now interpreted as if the user is logged into a basic single line extension on the system using their user settings. That also include user BLF status indication.

To use these features the user must be configured to support mobile call control.

#### **Warning:**

This feature allows external callers to use features on your phone system and to make calls from the phone system for which you may be charged. The only security available to the system is to check whether the incoming caller ID matches a configured users' **Twinned Mobile Number** setting. The system cannot prevent use of these features by caller's who present a false caller ID that matching that of a user configured for access to this feature.

#### **Trunk Restrictions:**

Mobile call control is only supported on systems with trunk types that can give information on whether the call is answered. Therefore, mobile call control is not supported on analog or T1 analog trunks. All other trunk types are supported (ISDN PRI and BRI, SIP (RFC2388), H323).

Routing via trunks that do not support clearing supervision (disconnect detection) should not be used.

DTMF detection is applied to twinned calls to a user configured for this feature. This will have the following effects:

DTMF dialing is muted though short chirps may be heard at the start of any DTMF dialing.

DTMF dialed by the user will not be passed through to other connected equipment such as IVR or Voicemail.

#### **Mobile Call Control Features and FNE Services:**

Mobile call control uses a short code set to invoke an FNE service. The codes relevant to mobile call control are summarized below.

- **FNE 31 = Mobile Call Control** This code allows a user called or calling the system to invoke mobile call control and to then handle and make calls as if they were at their system extension.

- **FNE 32 = Mobile Direct Access** Mobile direct access FNE32 immediately redials on switch the DDI digits received with the call rather than returning dial tone and waiting for DTMF digits as with FNE31 .
- **FNE 33 = Mobile Callback** Mobile callback allows the user to call the system and then hang up. The system will then make a call to the user's CLI and when answered, provide them with dial tone from the system to make calls.
- **FNE 35 = Simplified Mobile Call Control:** In addition to the Mobile Call Control feature that enables your mobile to make and handle calls as if your are using your extension, this Simplified Mobile Call Control FNE 35 clears the dial tone when the call recipient ends the call. The dial tone is provided on the mobile phone for fresh calls after the current call is cleared.
- **FNE 36 = Simplified Mobile Direct Access:** In addition to the Mobile Direct Access feature, the Simplified Mobile Direct Access FNE36 clears the dial tone when the call recipient ends the call.
- **FNE 37 = Simplified Mobile Callback:** In addition to the Mobile Callback feature that enables your mobile to get call back from the system and lets you use the dial tone for making and handling calls, this Simplified Mobile Callback FNE 37 clears the dial tone when the call recipient ends the call. The dial tone is provided on the mobile phone for fresh calls after the current call is cleared.

The codes relevant to mobility are summarized in the table.

FNE Number	Feature
00	System Dial Tone
01	Steal Call
02	Auto Call Back
04	Forward All Calls
05	Forward Busy and No Answer Calls
06	Call Forward Disable
07	Park Call
08	Call UnPark
09	Pick Up Group
10	Directed Call Pick Up
12	Withheld CLI (To External Calls off IPO)
13	Enable CLI (To External Calls off IPO)
14	Conference Add
15	Drop Call
16	Private Call (cannot be intruded or recorded)
17	Held Appearance Select
18	Same as FNE 00–Dial Tone Appearance (a=)

*Table continues...*

FNE Number	Feature
19	Enable Twinning
20	Disable Twinning
24	DND On
25	DND Off
26	Blind Transfer
27	Transfer to Voicemail

**Using Mobile Call Control:**

In addition to using \*\* to access mobile call control, the user has access to the following additional controls:

- **Clearing a Call: \*52** It may be necessary to clear a connected call, for example after attempting a transfer and hearing voicemail or ringing instead. To do this dial \*\* for dial tone and then \*52 (this is a default system short code and can be changed if required).
- **Return to Dial Tone: ##** Return to dial tone after getting busy, number unobtainable or short code confirmation tones from the system.

**Enabling Outgoing Mobile Call Control:**

1. **Configure the user for Mobile Twinning and Mobile Call Control** On the User | Mobility tab do the following:
  - Enable **Mobility Features** for the user.
  - Set the **Twinned Mobile Number** for the user's twinned calls destination.
    1. Digits are matched from right to left.
    2. The match must be at least 6 digits. If either the CLI or the Mobile Twinned Number is less than 6 digits no match will occur.
    3. Matching is done for up to 10 digits. Further digits are ignored. If either the CLI or Mobile Twinned Number is less than 10 digits, matching stops at that shorter length.
    4. If multiple matches occur the first user in the configuration is used. Manager will warn against configuration where such a conflict may exist.
  - Select **Can do Mobile Call Control**.

On systems with some unsupported trunk types, further changes such as Outgoing Group ID, system shorts codes and ARS may be necessary to ensure that calls to the mobile twinned numbers are only routed via trunks that support mobile call control.

**Incoming Mobile Call Control:**

The system can be configured to allow Mobile Call Control users to use this function when making an incoming call to the system. This requires the user to make the incoming call from the same CLI as their Mobile Twinning Number (even if they do not actually use Mobile Twinning).



The call will be rejected:

- If the caller ID is blank or withheld.
- If the caller ID does not match a Twinned Mobile Number of a user with **Can do Mobile Call Control** enabled.
- If the call is received on a trunk type that does not support Mobile Call Control.

### Enabling Incoming Mobile Call Control:

On the **User | Mobility** tab do the following:

1. Enable **Mobility Features** for the user.
2. Set the **Twinned Mobile Number** to match the CLI of the device from which the user will be making calls.
3. Select **Can do Mobile Call Control**.

**9x Add a FNE Short Code** In the system short codes section of the configuration add a short code similar to the following. Key points are the use of the **FNE Service** feature and the **Telephone Number** value **31**.

- **Short Code:** \*89
- **Feature:** FNE Service
- **Telephone Number:** 31

**➔ Add an Incoming Call Route for the user** Create an incoming call route that matches the user's CLI and with the FNE short code created above as its destination.

On systems with some unsupported trunk types, further changes such as Incoming Group ID changes may be necessary to ensure that only calls received on trunks that support Mobile Call Control are routed to this short code.

### Related links

[Configure User Settings](#) on page 662

[Mobile Direct Access \(MDA\)](#) on page 721

[Mobile Callback](#) on page 723

---

## Mobile Direct Access (MDA)

For a Mobile Call Control or one-X Mobile client user, FNE32 immediately redials on switch the DDI digits received with the call rather than returning dial tone and waiting for DTMF digits as with FNE31. This is called Mobile Direct Access (MDA).

MDA requires the user's external telephony provider to provide a direct trunk with DDI to the system (ie. an ISDN or SIP trunk). By assigning a specific incoming line group ID to the trunk, an incoming call route can be created for the same line group ID with blanks incoming number and incoming CLI fields. The destination is a short code set to FNE32.

## Configure User Settings

User validation is performed using the CLI in the same way as for normal Mobile Call Control. In addition the call will be rejected no DDI digits are provided. Once connected the user can use the other Mobile Call Control features such as \*\*.

The image shows a configuration interface for Avaya Manager, divided into four main sections:

- BRI Line:** Contains fields for Line Number (06), Card (2), Port (10), Telephone Number, Incoming Group ID (20), Prefix, Line SubType (ETSI), TEI (0), Outgoing Group ID (0), and Number of Channels (2).
- Standard:** Contains tabs for Standard, Voice Recording, and Destinations. The Standard tab is active, showing Bearer Capability (Any Voice) and Line Group Id (20).
- Destinations:** A table with columns TimeProfile, Destination, and Fallback Extension. The first row shows Default, \*99, and a dropdown arrow.
- Short Code:** Contains fields for Code (\*99), Feature (FNE Service), Telephone Number (32), and Line Group Id (0).

Blue arrows indicate the flow of configuration: from Incoming Group ID (20) in the BRI Line section to Line Group Id (20) in the Standard section, then to the Destination (\*99) in the Destinations table, and finally to the Feature (FNE Service) in the Short Code section.

### Related links

[Mobile Call Control](#) on page 718

---

## Mobile Callback

Mobile callback allows the user to call the system and then hang up. The system will then make a call to the user's CLI and when answered, provide them with dial tone from the system to make calls.

Mobile callback is subject to all the normal trunk type and user licensing restrictions of mobile call control. In addition the user must have the **Mobile Callback (User | Mobility)** setting enabled in the system configuration.

When the user makes a call using a DDI that is routed to an FNE33 short code, the system will not connect (answer) the call but will provide ringing while it waits for the user to hang up (after 30 seconds the system will disconnect the call).

- The system will reject the call if the CLI does not match a user configured for Mobile Callback or does not meet any of the other requirements for mobile call control.
- The system will reject calls using FNE33 if the user already has a mobile twinning or mobile call control call connected or in the process of being connected. This includes a mobile callback call in the process of being made from the system to the user.

If the CLI matches a user configured for mobile callback and they hang up within the 30 seconds, the system will within 5 seconds initiate a callback to that user's CLI.

- If the call is answered after the user's **Mobile Answer Guard** time and within the user's **No Answer Time**, the user will hear dial tone from the system and can begin dialling as if at their system extension.
- If the call is not answered within the conditions above it is cleared and is not reattempted.

### Related links

[Mobile Call Control](#) on page 718

---

## Twinning

Twinning allows a user's calls to be presented to both their current extension and to another number. The system supports two modes of twinning:

	Internal	Mobile
<b>Twinning Destination</b>	Internal extensions only	External numbers only.
<b>Supported in</b>	All locales.	All locales.
<b>License Required</b>	No	No

User BLF indicators and application speed dials set to the primary user will indicate busy when they are connected to a twinned call including twinned calls answered at the mobile twinning destination.

## Do Not Disturb and Twinning

### Mobile Twinning

Selecting DND disables mobile twinning.

### Internal Twinning

- Logging out or setting do not disturb at the primary stops twinned calls alerting at the secondary also.
- Logging out or setting do not disturb at the secondary only affects the secondary.

### Do Not Disturb Exceptions List

For both types of twinning, when DND is selected, calls from numbers entered in the user's Do Not Disturb Exception List are presented to both the primary and secondary phones.

### Internal Twinning

Internal twinning can be used to link two system extensions to act as a single extension. Typically this would be used to link a users desk phone with some form of wireless extension such as a DECT or WiFi handset.

Internal twinning is an exclusive arrangement, only one phone may be twinned with another. When twinned, one acts as the primary phone and the other as the secondary phone. With internal twinning in operation, calls to the user's primary phone are also presented to their twinned secondary phone. Other users cannot dial the secondary phone directly.

- If the primary or secondary phones have call appearance buttons, they are used for call alerting. If otherwise, call waiting tone is used, regardless of the users call waiting settings. In either case, the **Maximum Number of Calls** setting applies.
- 
- Calls to and from the secondary phone are presented with the name and number settings of the primary.
- The twinning user can transfer calls between the primary and secondary phones.
- Logging out or setting do not disturb at the primary stops twinned calls alerting at the secondary also.
- Logging out or setting do not disturb at the secondary only affects the secondary.
- User buttons set to monitor the status of the primary also reflect the status of the secondary.
- Depending on the secondary phone type, calls alerting at the secondary but then answered at the primary may still be logged in the secondary's call log. This occurs if the call log is a function of the phone rather than the system.
- Call alerting at the secondary phone ignoring any **Ring Delay** settings applied to the appearance button being used at the primary phone. The only exception is buttons set to No Ring, in which case calls are not twinned.

The following applies to internal twinned extensions:

If using a 1400, 1600, 9500 or 9600 Series phone as the secondary extension:

- The secondary extension's directory/contacts functions access the primary user's Centralized Personal Directory records in addition to the Centralized System Directory.

- The secondary extension's call Log/call List functions access the primary user's Centralized Call Log.
- The secondary extension's redial function uses the primary users Centralized Call Log. Note that the list mode or single number mode setting is local to the phone.

It is also shown on 3700 Series phones on a DECT R4 system installed using system provisioning .

For all phone types, changing the following settings from either the primary or secondary extension, will apply the setting to the primary user. This applies whether using a short code, programmable button or phone menu. The status of the function will be indicated on both extensions if supported by the extension type.

- Forwarding settings.
- Group membership status and group service status.
- Voicemail on/off.
- Do Not Disturb on/off and DND Exceptions Add/Delete.

### Mobile Twinning

This method of twinning can be used with external numbers. Calls routed to the secondary remain under control of the system and can be pulled back to the primary if required. If either leg of an alerting twinned call is answered, the other leg is ended.

Mobile twinning is only applied to normal calls. It is not applied to:

- Intercom, dial direct and page calls.
- Calls alerting on line appearance, bridged appearance and call coverage buttons.
- Returning held, returning parked, returning transferred and automatic callback calls.
- Follow me calls.
- Forwarded calls except if the user's **Forwarded Calls Eligible for Mobile Twinning** setting is enabled.
- Hunt group calls except if the user's **Hunt Group Calls Eligible for Mobile Twinning** setting is enabled.
- Additional calls when the primary extension is active on a call or the twinning destination has a connected twinned call.

A number of controls are available in addition to those on this tab.

### Button Programming Actions:

The **Emulation | Twinning** action can be used to control use of mobile twinning. Set on the primary extension, when that extension is idle the button can be used to set the twinning destination and to switch twinning usage on/off. When a twinned call has been answered at the twinned destination, the button can be used to retrieve the call at the primary extension.

### Mobile Twinning Handover:

When on a call on the primary extension, pressing the **Twinning** button will make an unassisted transfer to the twinning destination. This feature can be used even if the user's **Mobile Twinning** setting was not enabled.

- During the transfer process the button will wink.
- Pressing the twinning button again will halt the transfer attempt and reconnect the call at the primary extension.
- The transfer may return if it cannot connect to the twinning destination or is unanswered within the user's configured **Transfer Return Time** (if the user has no **Transfer Return Time** configured, a enforced time of 15 seconds is used).

#### Short Code Features:

The following short code actions are available for use with mobile twinning.

- **Set Mobile Twinning Number.**
- **Set Mobile Twinning On.**
- **Set Mobile Twinning Off.**
- **Mobile Twinned Call Pickup.**

#### Related links

[Configure User Settings](#) on page 662

---

## Private Calls

This feature allows users to mark a call as being private.

When on, any subsequent calls cannot be intruded on until the user's private call status is switched off. The exception is Whisper Page which can be used to talk to a user on a private call.

Note that use of private calls is separate from the user's intrusion settings. If the user's **Cannot be Intruded** (User | Telephony | Supervisor Settings) setting is enabled, switching private calls off does not affect that status. To allow private calls to be used to fully control the user status, **Cannot be Intruded** (User | Telephony | Supervisor Settings) should be disabled for the user.

Use of private calls can be changed during a call. Enabling privacy during a call will stop any current recording, intrusion or monitoring. Privacy only applies to the speech part of the call. Call details are still recorded in the SMDR output and other system call status displays.

**Button Programming** The button programming action **Advanced | Call | Private Call** can be used to switch privacy on/off. Unlike the short code features it can be used during a call to apply or remove privacy from current calls rather than just subsequent calls. On suitable phones the button indicates the current status of the setting.

**Short Codes** A number of short code features are available for privacy.

- **Private Call** Short codes using this feature toggle private status on/off for the user's subsequent calls.

- **Private Call On** Short codes using this feature enable privacy for all the user's subsequent calls until privacy is turn off.
- **Private Call Off** Short codes using this feature switch off the user's privacy if on.

### Related links

[Configure User Settings](#) on page 662

---

## System Phone Features

The user option **System Phone Rights** (User | User) can be used to designate a user as being a system phone user. System phone users can access a number of additional function not available to other phone users. Note that if the user has a login code set, they will be prompted to enter that code in order to access these features..

- **None** The user cannot access any system phone options.
- **Level 1** The user can access all system phone options supported on the type of phone they are using except system management and memory card commands.
- **Level 2** The user can access all system phone options supported on the type of phone they are using including system management and memory card commands. Due to the nature of the additional commands a login code should be set for the user to restrict access.

### System Phone Functions:

The following functions are supported:

- **MENU to set date/time** Restricted to 4412, 4424, 4612, 4624, 6408, 6416 and 6424 phones where supported by the system. Note 4612 and 4624 not support for 4.1+. On these phones, a system phone user can manually set the system date and time by pressing **Menu | Menu | Func | Setup**.
- **SoftConsole Send Message** If the system phone user is using SoftConsole, they can access the SoftConsole function **Send Message** to send a short text message (up to 16 characters) to a display phone. Refer to the SoftConsole documentation for details. Note that this is no longer required for 4.0+.
- **Change Login Code of Other Users** Using a short code with the Change Login Code feature, system phone users can change the login code of other users on the system.
- **Outgoing Call Bar Off** Using a short code with the Outgoing Call Bar Off feature, system phone users can switch off the outgoing call bar status of other users on the system. .

The following commands are only supported using 1400, 1600, 9500 and 9600 Series phones. Due to the nature of the commands a login code should be set for the user to restrict access. The commands are accessed through the **Features | Phone User | System Administration** menu. For full details refer to the appropriate phone user guide.

- **Edit System Directory Records** Using a 1400, 1600, 9500 or 9600 Series phone, a system phone user can edit system directory records stored in the configuration of the system on which they are hosted. .They cannot edit LDAP and/or HTTP imported records.

- **System Management** (IP500 V2 only) Allows the user to invoke a system shutdown command.
- **Memory Card Management** Allows the user to shutdown, startup memory cards and to perform actions to move files on and between memory cards.
- **System Alarms** (IP500 V2 only) For certain events the system can display an **S** on the user's phone to indicate that there is a system alarm. The user can then view the full alarm text in the phone's Status menu. The possible alarms in order of priority from the highest first are:
  1. Memory Card Failure.
  2. Expansion Failure.
  3. Voicemail Failure.
  4. Voicemail Full.
  5. Voicemail Almost Full.
  6. License Key Failure.
  7. System Boot Error.
  8. Corrupt Date/Time.
- **Date/Time Programmable Button:** Allows system phone users to manually set the system date and time through a programmable button (see [System Date and Time](#) on page 596).

#### Related links

[Configure User Settings](#) on page 662

---

## The 'No User' User

It is possible to have an extension which has no default associated user. This can occur for a number of reasons:

- The extension has no **Base Extension** setting associating it with a user who has the same setting as their **Extension** to indicate that they are the extension's default associated user.
- The extension's default associated user has logged in at another extension. Typically they will be automatically logged back in at their normal extension when they log out the other phone.
- The extension's default associated user cannot be automatically logged in as they are set to **Forced Login**.

Phones with no current user logged in are associated with the setting of the **NoUser** user in the system configuration. This user cannot be deleted and their Name and Extension setting cannot be edited. However their other settings can be edited to configure what functions are available at extensions with no currently associated user.



By default the **NoUser** user has **Outgoing Call Bar** enabled so that the extension cannot be used for external calls. The users first programmable button is set to the **Login** action.

Avaya 1100 Series, 1200 Series, M-Series and T-Series phones, when logged out as **No User**, the phones are restricted to logging in and dial emergency calls only.

### NoUser Source Numbers

The **SourceNumbers** tab of the **NoUser** user is used to configure a number of special options. These are then applied to all users on the system. For details refer to the **User | Source Numbers** section.

#### Related links

[Configure User Settings](#) on page 662

[Suppressing the NoCallerId alarm](#) on page 729

---

## Suppressing the NoCallerId alarm

Use this procedure to suppress the NoCallerId alarm for all users on the system. Once the task is completed, the NoCallerID alarm is not raised in SysMonitor, SNMP traps, email notifications, SysLog or System Status.

### Procedure

1. In Manager, in the navigation pane on the left, select **User**.
2. In the list of users, select **NoUser**.
3. In the details pane, select the **Source Numbers** tab.
4. Click **Add**.
5. In the **Source Number** field, enter **SUPPRESS\_ALARM=1**.
6. Click **OK**.

#### Related links

[The 'No User' User](#) on page 728





---

## Transferring Calls

The following are some of the methods usable to transfer calls.

- **Supervised Transfer:** This is a transfer where the user waits for the transfer destination to answer and talks to that party before completing the transfer, this is referred to as a consultation call. They then either complete the transfer or drop the call and return to the held for transfer call. The call details, display, ringing and forwarding applied are appropriate to the type of call (internal or external) being transferred.
- **Unsupervised Transfer:** This is a transfer completed whilst the destination is still ringing.

- **Automatic Transfer - Forwarding:** The system allows users to automatically transfer calls using forwarding options such as Forward on Busy, Forward on No Answer and Forward Unconditional. For full details see DND, Follow Me and Forwarding.
- **Transfers to a Forwarded Extension:** When transferring a call to another extension that has forwarding enabled, the type of call being transferred is used. For example, if transferring an external call, if the transfer target has forwarding of external calls enabled then the forward is used.
- **Transfer Return Time (secs):** Default = Blank (Off), Range 1 to 99999 seconds.  Sets the delay after which any call transferred by the user, which remains unanswered, should return to the user. A return call will continue ringing and does not follow any forwards or go to voicemail.
  - Transfer return only occurs if the user has an available call appearance button.
  - Transfer return is not applied if the transfer is to a hunt group that has queuing enabled.

Tool	Unsupervised Transfer	Supervised Transfer	Reclaim
Analog Phone/ Single Line Phones	<ol style="list-style-type: none"> <li>1. Press R. Note that broken dial tone is heard while a call is on hold.</li> <li>2. Dial the transfer destination number.</li> <li>3. Hang-up.</li> </ol>	<ol style="list-style-type: none"> <li>1. Press R.</li> <li>2. Dial the transfer destination number.</li> <li>3. If the destination answers and accepts the call, hang-up.</li> <li>4. If the called party does not answer or does not want to accept the call, press R again.</li> <li>5. To return to the original caller press R.</li> </ol>	*46
Avaya DS Phone	<ol style="list-style-type: none"> <li>1. Press  <b>Transfer</b>.</li> <li>2. Dial the transfer destination number.</li> <li>3. Press  <b>Transfer</b> again to complete the transfer.</li> </ol>	<ol style="list-style-type: none"> <li>1. Press  <b>Transfer</b>.</li> <li>2. Dial the transfer destination number.</li> <li>3. If the destination answers and accepts the call, press  <b>Transfer</b> again to complete the transfer.</li> <li>4. If the called party does not answer or does not want to accept the call, press  <b>Drop</b>.</li> <li>5. To return to the original caller press it's call appearance button.</li> </ol>	*46

**Related links**

[Configure User Settings](#) on page 662

---

## Off-Switch Transfer Restrictions

Users cannot transfer calls to a destination that they cannot normally dial. This applies to manual transfers and also to automatic transfers (forwarding). In addition to call barring applied through short codes, the following system settings may restrict a users ability to transfer calls.

### User Specific Controls

**Outgoing Call Bar:** Default = Off (**User | Telephony | Supervisor Settings**) When enabled, this setting stops a user from making any external calls. It therefore stops them making any external transfers or forwards.

**Inhibit Off-Switch Forward/Transfer:** Default = Off (**User | Telephony | Supervisor Settings**). When enabled, this setting stops the specific user from transferring or forwarding calls externally. This does not stop another user transferring the restricted users calls off-switch on their behalf.

When either system or user **Inhibit Off-Switch Forward/Transfer** is enabled, it affects the operation of the user's phone and applications. User attempts to set an external forward destination via a short code will receive error tone. User attempt to set an external forward destination via a programmable button on their phone will not have a Next option allowing the number to be saved.

### Line Specific Control

**Analog Trunk to Trunk Connection:** Default = Off (**Line | Analog Line | Analog Options**) When not enabled, users cannot transfer or forward calls on one analog trunk back off-switch using another analog trunk.

### System Wide Controls

**Inhibit Off-Switch Forward/Transfer:** Default = Off (**System | Telephony**) When enabled, this setting stops any user from transferring or forwarding calls externally.

**Restrict Network Interconnect:** Default = Off (**System | Telephony**). When this option is enabled, each trunk is provided with a Network Type option that can be configured as either **Public** or **Private**. The system will not allow calls on a Public trunk to be connected to a Private trunk and vice versa, returning busy indication instead.

Due to the nature of this feature, its use is not recommended on systems also using any of the following other system features: multi-site networks, VPNremote, application telecommuter mode.

### Conference Control

Users can use conference controls to effectively transfer calls. This includes transferring an external call to another external number. The use of conferencing to effect off-switch transfers can be restricted using the **Inhibit External Only Impromptu Conference** setting (**System | Telephony**).

---

## Context Sensitive Transfer

**Calls and Button Status Indication** The status indication for a call on hold pending transfer has changed to differentiate such calls from standard held calls:

- On phones with both dual lamp buttons, both the green and red lamps fast flash (flutter) when the button represents a call on hold pending transfer.
- On phones with single lamp buttons or status icons, **Xfer:** is now shown in front of the caller ID information rather than the button name. For example **Xfer:Extn299** is shown rather than **a = Extn299**.
- The call status information shown when the button of a call on hold pending transfer is the currently highlight line is now prefixed with **On-Hold-Xfer** rather than **On-Hold**.

**Switching Between Calls** Switching from a connected call to an existing call on hold pending transfer puts the connected call on hold pending transfer. The following table is an example of the resulting operation .

Call or answer A	Connected to A
Press Transfer	A on hold pending transfer
Call or answer B	A on hold pending transfer. Connected to B.
Reconnect to A	Connected to A. B on hold pending transfer
Press Transfer or <b>Complete*</b> .	A transferred to B.

**Requirement for a Free Call Appearance Before Starting a Transfer** When the user already has a call or calls on hold, they can now put their current call on hold pending transfer even if there are no free call appearances available. Previously an available call appearance was required in order to then make a consultation call to the potential transfer destination.

**Conferencing Calls** For these phone there have also been changes to which calls are conferenced in different scenarios including when there is a call on hold pending transfer. See Context Sensitive Conferencing.

---

## Dial Tone Transfer

Release 5.0+: A user who is not able to make external calls to any or some external numbers, can be transferred to dial tone by a user who is able to make external calls.

- The restricted user wanting to make the external call, dials the unrestricted user and requests dial tone.
- The unrestricted user initiates a transfer and dials the prefix for an ARS form configured to provide secondary dial tone.

The prefix is a short code set up to access the required ARS form. While this can be a system short code, using a user or user rights short code will allow control over who can provide dial tone transfer for restricted users.

- When they hear the secondary dial tone, the unrestricted user completes the transfer.
- The restricted user now hears the secondary dial tone and is now able to make an external call.
- The restricted user is now able to make calls as permitted by the short codes in the ARS form.
- The restricted user is not able to transfer the dial tone to another user.

The ARS form being used can still contain short codes that restrict the dialing that can be attempted after the restricted user hears secondary dial tone. Other ARS features can also be used such as alternate routing or time profiles to provide out of hours routing. The ARS form timers are run from when the unrestricted caller dials the ARS form. They are not reset when the restricted user is transferred to the ARS form.

Multiple prefixes and ARS forms can be used if required to create more complex scenarios. For example, one where the unrestricted user can transfer the restricted users to an ARS forms that allows international calls or to an ARS form that only allows national dialing.

### Example Configuration:

The example below is a simple configuration that allows the unrestricted user to use 8 as a transfer destination that provides secondary dial tone.

**Create an ARS Form for Secondary Dial Tone** The ARS form needs to be created before short codes can be added to route callers to it.

- Enter a **Route Name** to identify the ARS form, for example `Dial Tone Trans.`
- Select **Secondary Dial Tone**.
- Select either **System Tone** (this matches locale specific normal dial tone) or **Network Tone** (this matches locale specific secondary dial tone). For some locales both tones are the same.
- Enter short codes that will take any digits dialed by the restricted user and process them for external dialing to an outgoing line group. For this example we will allow any digits dialed to be presented to the first trunk seized in outgoing line group 0.

<b>Code</b>	N
<b>Telephone Number</b>	N
<b>Feature</b>	Dial
<b>Line Group ID</b>	0

- Other short codes can be used to allow or bar the dialing of specific numbers or types of numbers.
- Configure the rest of the ARS form as required. For full details on ARS form configuration see ARS.

**Create a Short Code for Dial Tone Transfer** For this example we will allow the prefix 8 to be used to access an ARS form created above.

In the user short codes of the unrestricted user, create a short code that invokes the ARS form created above. For example:

<b>Code</b>	8
<b>Telephone Number</b>	
<b>Feature</b>	Dial
<b>Line Group ID</b>	51 Dial Tone Trans

- It is important that the short code does not pass any digits to the ARS form. Once the ARS form receives any digits, it starts short code matching and ends secondary dial tone.
- The short code could also be setup as a system or user rights short code.

The unrestricted user is now able to provide secondary dial tone to other users by on request by pressing **Transfer**, dialing **8** and then pressing **Transfer** again.

**Account and Authorization Codes:**

If the restricted user enters an account or authorization code while calling the unrestricted user to request dial tone, that value is not carried forward with their external call once they have been provided with secondary dial tone.

If the unrestricted user enters an account or authorization code while dialing the ARS form, that value remains associated with the call made by the restricted user.

If the ARS form short code used to route the restricted users call requires an account or authorization code, the value already entered is used, otherwise the restricted user is prompted to enter a value.

**Call Logging:**

The restricted user's outgoing call log will include the call to the unrestricted user and the outgoing external call they subsequently make. The outgoing external call record will include the prefix dialed by the unrestricted user to access the ARS form.

The unrestricted users call log will include just an incoming call from the restricted user.

Within the SMDR output, the calls by the restricted user are included. The call by the unrestricted user is not included.

## Handsfree Announced Transfers

This feature allows the enquiry call part of a supervised transfer to be answered handsfree. In addition the system can be optionally configured to allow both the enquiry call and completed transfer call to be auto-answered.

**Example:**

1. User 201 answers a call that they then want to transfer to user 203.

2. They press **Transfer** to put the call on hold pending transfer.
3. They then press a **Dial Direct** button and dial 203.
4. The transfer enquiry call is auto answered by User 203's phone. User 201 is able to announce the pending transfer and hear if User 203 wants to accept the call.

The auto-answer only occurs if the target user's extension is idle. If the target is already connected to a call, the transfer enquiry will be presented as normal call.

If the transfer is accepted, User 201 can press **TRANSFER** again to complete the transfer process.

The transferred call will then ring at the target. However, if required the system can be configured to also auto-answer the completed transfer.

### Configuration:

Handsfree announced transfers are supported when using one of the following features after having pressed **TRANSFER**.

Button Features	Short Code Features
Dial Direct Automatic Intercom Dial Intercom	Dial Direct

### User Button Usability:

Following the use of any of the buttons above, if the button has not been programmed with a specific target, a User button can be used to indicate the target for the enquiry call. This gives the advantage of being able to see the target user's status before attempting the transfer.

- For **Automatic Intercom** and **Dial Intercom** buttons without a pre-specified target, the **User** button must be on a button module.
- For **Dial Direct** buttons without a pre-specified target, the **User** button can be on the phone or button module. Due to this and the support for **Dial Direct** across a network of systems, we recommend that a **Dial Direct** button is used for handsfree announced transfers.

### Phone Support:

Handsfree announced transfer is supported for calls being transferred to the following phones:

Full Support	Partial Support	Not Supported
The following system phones support full announced transfer operation. <b>1603, 1608, 1616, 2410, 2420, 5410, 5420, 4610, 4621, 4625, 5610, 5620, 5621.</b> <b>Analog Off-Hook Stations</b> (See notes below).	The following phone can auto-answer announced transfers but require the user to use the handset to respond. <b>2402, 4601, 4602, 5402, 5601, 5602.</b>	Announced transfer is not supported for any phones not listed in the other column. On unsupported phones the transfer enquiry consultation call will be presented as a normal call.

**Notes:**

- On supported phones, if the target user's phone is not idle when the enquiry call attempt is made, the enquiry call is turned into a normal transfer attempt, eg. alerting on an available call appearance.
- Enabling the extension specific setting **Disable Speakerphone** will turn all auto-answer calls, including handsfree announced transfers to the extension, into normal calls.
- **Off-Hook Station Analog Phones** Analog phone extensions configured as Off-Hook Station can auto-answer transfers when off-hook and idle.
- **Headset Users** The following applies to users on supported phones with a dedicated **HEADSET** button. These users, when in headset mode and idle will auto-answer the announced transfer enquiry call through the headset after hearing 3 beeps. The transfer completion will require them to press the appropriate call appearance unless they are set to Headset Force Feed.
- **Twining** Handsfree announced transfer calls to users with twinning enabled will be turned into normal calls.
- **Multi-site network Support** Dial Direct is supported to targets across a multi-site network, therefore allowing handsfree announced transfers to remote users.

**Full Handsfree Transfer Operation:**

If required the system can be configured to allow the full handsfree announced transfer process, ie. both the enquiry call and the transfer, to be auto-answered on supported phones. This is done by entering `FORCE_HANDSFREE_TRANSFER` into the Source Numbers of the NoUser user and rebooting the system

---

## One Touch Transferring

This feature allows selected users to transfer calls to each other using a reduced number of key presses.

With this option, a call can be transferred by simply selecting the transfer destination and then hanging up (or pressing **Transfer** if working handsfree).

Without this option the normal sequence is to press **Transfer**, dial the destination and then hanging up (or pressing **Transfer** if working handsfree).

For one touch transfer the transfer destination number must be selected using a button programmed to one of the following features:

- **User**
- **Dial**
- **Abbreviated Dial**
- **Automatic Intercom**
- **Dial Intercom**



- **Dial Direct**

This feature is enabled on a per user basis by adding `Enable_OTT` to the **Source Number** settings of the user. This feature is supported on all Avaya phones that support the programmable button features.

---

## Centrex Transfer

Centrex Transfer is a feature provided by some line providers on external analog lines. It allows the recipient of a calls on such a line to transfer that call to another external number. The transfer is performed by the line provider and the line is freed. Without Centrex Transfer, transferring an external call to another external number would occupy both a incoming and outgoing line for the duration of the call.

The following are the supported controls and usages for Centrex Transfer:

- **Centrex Transfer Button Operation** The action **Flash Hook** can be assigned to a programmable button. This button can be configured with or without a telephone number for an automatic or manual transfer.
  - **Manual Transfer** If the programmable button is setup without a target telephone number, pressing the button returns dial tone to the user. They can then dial the required transfer number and when they hear ringing or an answer, hang up to complete the Centrex Transfer.
  - **Automatic Transfer** If the programmable button is setup with a target telephone number, pressing the button performs the Centrex Transfer to the number as a single action.
- **Centrex Transfer Short Code Operation** The **Flash Hook** short code feature can be used with system short codes. It can be setup with or without a telephone number in the same way as a Flash Hook programmable button above. The line group must be the group of analog lines from the Centrex service line provider.
  - **Centrex Transfer Operation for Analog Extensions** Most analog phones have a button that performs the action of sending a hook flash signal. The marking of the button will vary and for example may be any of **R**, **H**, **Recall** or **Hold**. Pressing this button sends a hook flash to the system to hold any current call and return dial tone.
    - To perform a Centrex Transfer, pressing the analog extension's hook flash button should be followed by the dialing of a **Flash Hook** short code.
    - For analog extension users with call waiting enabled, pressing the hook flash button during a call will hold the current call and connect any call waiting. Therefore it is recommend that analog extension users wanting to use Centrex Transfer should not also have call waiting enabled.
- **Auto Attendant Transfer** System's using embedded voicemail can select Centrex Transfer as an action. For system using Voicemail Pro, the equivalent can be achieved by transferring calls to a **Flash Hook** short code.

### Additional Notes

- **Networked Systems** In networked systems, Centrex Transfer is only supported using **Flash Hook** or **Centrex Transfer** features on the system which hosts the Centrex analog trunks.
- **Addition Prefix Dialing** In some cases the Centrex service provider may require a prefix for the transfer number. If that is the case, that prefix must be inserted in the button programming or the short code used for the Centrex Transfer.
- **Application Transfers** Centrex Transfer is not supported for calls being held and transferred through applications such as SoftConsole.
- **Conference Calls** Centrex Transfer is not supported with conference calls.

---

## Avaya cloud authorization

Using Avaya cloud authorization, you can configure the Avaya Workplace Client connection using your Google, Office 365, Salesforce account, Avaya native spaces email account, or Enterprise Account (SSO).

You can configure the Avaya Workplace Client settings automatically using your email address or the automatic configuration web address.

Enabling Avaya cloud authorization automatically uses your network login and password to access different enterprise systems with a single sign-on. Using Avaya cloud authorization, you do not need to separately login to each system or service in your organization.

 **Note:**

Avaya Cloud Account Authorization works only on TLS transport type.

### Related links

[Configure User Settings](#) on page 662

---

## Configuring automatic synchronization

### About this task

Use this procedure if you have an Avaya Workplace Client account and want to sign in to Avaya Workplace Client. You can configure the Avaya Workplace Client settings automatically using your email address or the automatic configuration web address.

Use this procedure to enable automatic synchronization and Avayacloud authorization. See [Avaya Cloud Services](#) on page 278 for field descriptions.

### Before you begin

To enable synchronization, the customer domain must be verified.

## Procedure

1. Select **System Settings > System > Avaya Cloud Services**.
2. Select **Enable Avaya Cloud Account** check box.
3. In the company domain, type the customer's verified domain.
4. Select **Enable User Synchronization**.
5. Set the **Enable Setting file URL sync** setting to set **Enable for current IP Office node** or **Enable for all IP Office nodes**.
6. Click **OK**.

## Related links

[Configure User Settings](#) on page 662

---

# Enabling Avaya cloud account authorization

## About this task

The **Unique Identity** setting is used to configure Avaya Workplace Client connection using your Google, Office 365, Salesforce account, Avaya native spaces email account, or Enterprise Account (SSO).

Ensure to configure email address in **Unique Identity** settings in **User > User > Unique Identity**, see [Avaya Cloud Services](#) on page 278 for field descriptions.

### **Note:**

Avaya Cloud Account Authorization works only on TLS transport type.

Use this procedure to enable Avaya cloud account authorization.

## Procedure

1. Select **System Settings > System > Avaya Cloud Services**.
2. Select **Enable Avaya Cloud Account Authorization**.
3. Click **OK**.

## Related links

[Configure User Settings](#) on page 662

---

## Configuring token cache time

### About this task

Use this procedure to enable token cache time. See [Avaya Cloud Services](#) on page 278 for field descriptions.

### Procedure

1. Select **System Settings > System > Avaya Cloud Services**.
2. In the **Token Cache Time** field, enter the time for which the token is cached in IP Office.  
The minimum token cache time is 15 minutes and maximum is 1 hour. The default value is 15 minutes.
3. Click **OK**.

### Related links

[Configure User Settings](#) on page 662

---

## Apple push notification services

Apple Push Notification service (APNs) is a platform notification service created by Apple Inc. This service allows iOS users of Avaya Workplace Client for iOS to receive notification of new calls, voicemail messages, and other events. They receive these notifications regardless when the Avaya Workplace Client for iOS is idle in the background or is in quit state. However, if Avaya Workplace Client for iOS is on suspension, then Avaya Workplace Client for iOS automatically starts when a new call or instant message notification arrives.

### \* Note:

Apple Push Notification service (APNs) works only on TLS transport type.

The iOS device sends notifications via an intermediate push notifications server provided by Avaya.

Avaya Workplace Client for iOS 3.8 and 3.8.4 supports the push notifications feature.

- On receiving a new call notification, and while Avaya Workplace Client for iOS is on suspension, it takes up to six seconds before the Avaya Workplace Client for iOS becomes active, and you can answer the call. The exact delay depends on the version of iOS and the device used. Therefore, the **No Answer Time** setting time is increased to more than 20 seconds to allow the calls to ring before going to voicemail or following the divert on no answer settings.
- APNs service supports only a single iOS device per user. If the you use Avaya Workplace Client for iOS on two devices, for example, an iPad and an iPhone, only the last client to register will receive notifications.

- While using iOS push notifications, always configure and enable voicemail or an alternate call destination number. When Avaya Workplace Client for iOS is not reachable, the **No Answer Time** setting triggers and the push notifications to a voicemail or a forward on no answer number.
- Setting your iOS device with a GSM telephone number as your mobile twinning, and setting the **Mobile Dial Delay** (sec) to more than 10 seconds, allows the time for the call notification to be answered on a previously suspended client before it alerts the GSM call.

**\* Note:**

In IP Office, while using iOS push notifications, if you were using a secured port in the primary server, use the same secured port as a preferred port in secondary server. Any mismatch in the secured port configuration is not valid.

**Related links**

[Configure User Settings](#) on page 662

---

## Enabling Apple push notifications

### About this task

Apple Push notifications for Avaya Workplace Client on iOS devices.

Use this procedure to enable the push notifications to allow the clients to receive call and voicemail message notifications.

**\* Note:**

When Avaya Workplace Client in your iOS device, such as iPad or iPhone, is in suspended state or quit state and you log in to another Android or Windows based mobility or desktop device using the same user, IP Office deletes the associated application device token and unregisters your iOS device if registered. When you log in using the same user, you must manually logout and login to the the iOS device to reactivate the token so that you can receive push notification calls.

### Before you begin

- All IP Office's in Small Community Networking (SCN) should have egress public access to connect to Apple Push Notification Provider (APNP) to support push notification to Avaya Workplace Client.
- In the case of IP Office 500v2 systems in SCN or Server Edition without a centralized primary, ensure the company domain is configured and verified.
- The API Key and Secret Key values are entered in the IP Office Manager security settings.

### Procedure

1. Select **System Settings > System > Avaya Push Notification Services**.
2. Select **Enable Apple Push Notification Services**.

3. Click **OK**.

 **Note:**

Increase the **No Answer Time** settings while using Avaya Workplace Client on iOS devices to at least 20 seconds. This can be done either by:

- Go to **System Settings > System > Telephony > Telephony** and increase the **Default No Answer Time** settings
- Select **Call Management > Users > Add > Telephony > Call Settings** and increase the **No Answer Time** setting of the individuals.

**Related links**

[Configure User Settings](#) on page 662

# Part 4: Configuring IP Office

# Chapter 14: Configure Server Edition system settings

---

## Synchronizing Server Edition passwords in Web Manager

In order to open IP Office Manager for a Server Edition solution, all IP Office systems in the solution must have a service user with common credentials. If the security settings on any system are reset, service user passwords are reset to the default value. In this case, when a system does not have a service user with common credentials, launch of IP Office Manager fails.

### Before you begin

You must know the user ID and password of the service user that is common to all systems in the solution.

### Procedure

1. For the system where the security settings were reset, open Web Manager using the address `https://<ip_address>:7070/WebManagement/WebManagement.html`.
2. Log on as **Administrator**.
3. In Web Manager, select **Security Manager > Service Users**.
4. Create the common service user.
5. Log out of this Web Manager session.
6. Start another Web Manager session on the system using the address `https://<ip_address>/index.html`.
7. Log on as the common service user.
8. In Web Manager, select **Security Manager > Service Users**.
9. Click **Synchronize Service User and System Password**.
10. Select **Applications > IP Office Manager**.



---

## Shared Administration User Account

### About this task

When managing multiple systems, it may be useful to create a common user name and password on all the systems for configuration access. This tool can be used to create a new service user account, **SCN\_Admin**, for configuration access.

This process requires you to have a user name and password for security configuration access to each of the systems.

Managing a Common Configuration Administration Account

### Procedure

1. Select **Tools | Server Edition Service User Management**.
2. The **Select IP Office** menu displays the list of discovered systems.
3. Select the systems for which you want to create a common configuration account.  
Typically this should be all systems. Click **OK**.
4. A user name and password for security configuration access to each system is requested.  
Enter the values and click **OK**. If the same values can be used for all systems enter those values, select **Use above credentials for all remaining, selected IPOs**. If each system requires a different security user names and password, deselect **Use above credentials for all remaining, selected IPOs**.
5. The systems will be listed and whether they already have an **SCN\_Admin** account is shown.
6. To create the **SCN\_Admin** account on each system and set the password for those account click on **Create Service User**.
7. Enter the common password and click **OK**.
8. The password can be changed in future using the Change Password option.
9. Click **Close**.

---

## Voicemail Administration

If the Voicemail Pro client application is installed on the same PC as Manager, it can be launched from Manager. If not already installed, the Voicemail Pro client application can be downloaded from the Primary Server via its web control menus. Refer to the Server Edition Deployment Guide.

Starting the Voicemail Pro Client

Using the following method automatically starts the Voicemail Pro client with information about the system to be administered.

1. In the Server Edition Solution View, select the server for which you want to administer the voicemail application that the server hosts. This can be either the Primary Server or Secondary Server. If **Solution** is selected, it is assumed that the voicemail server on the Primary Server is being administered.
2. Click on the  **Voicemail Administration** link on the right-hand edge of the menu.

#### Alternate Method

The Voicemail Pro client can . When started this way, it will be necessary to manually enter the IP address and other details of the system you want to monitor after starting the System Status Application.

Click **File | Advanced | Launch Voicemail Pro Client**.

---

## Server Edition Resiliency

### Related links

[Voicemail Pro Resiliency](#) on page 748

[Avaya one-X Portal resiliency](#) on page 750

[Phone Resiliency](#) on page 752

[Configuring Resiliency](#) on page 755

## Resilience

A single Server Edition Primary server supports redundant hard disk drives and power supply units. You can also configure Alternate Route Selection.

Add a Server Edition Secondary to provide resilience at any level. The Server Edition Secondary Server provides resilience for the Server Edition Primary Server users, H.323 and SIP extensions, hunt groups, and voicemail without any administration. The Server Edition Secondary server can provide resilience for Avaya one-X<sup>®</sup> Portal for IP Office.

A Server Edition Expansion System can be backed up to either the Server Edition Primary, Server Edition Secondary, or another Server Edition Expansion System. The dual star Multi-Site Network topology when a Server Edition Secondary Server is present supports diverse routing between all nodes.

For Server Edition Select deployments, IP Office Lines (SCN trunks) can be configured between Server Edition Expansion Systems. Hunt groups can be configured local to the Expansion system and resiliency for hunt groups and phones can be configured, with failover to the Server Edition Primary, Server Edition Secondary, or another Server Edition Expansion System.

At all times, no server hardware is forced to be idle, enabling you decide whether to provide true redundancy, or shared resource resilience.

The IP Office Server Edition Solution provides resilience for supported H.323 phones, SIP endpoints, and DECT R4 deployments. IP Office Lines between systems can be configured to

allow control to be automatically passed to a backup IP Office when the home system is not available.

### **Resilient components**

The following components of IP Office Server Edition Solution are resilient:

- IP Office Server Edition
- Voicemail Pro server
- Avaya one-X® Portal server
- H.323 telephones
- SIP endpoints
- DECT R4
- Hunt groups
- Interdevice links
- Trunks
- Incoming Call Routes
- Management

### **Multisite network**

A multisite network enhances resilience by providing the following capabilities:

- Transparency for most of the features
- Resilience of users and hunt groups
- Back up system for Voicemail Pro
- Network topology provides resilience
- None of the hardware is idle
- Simple to activate resilience

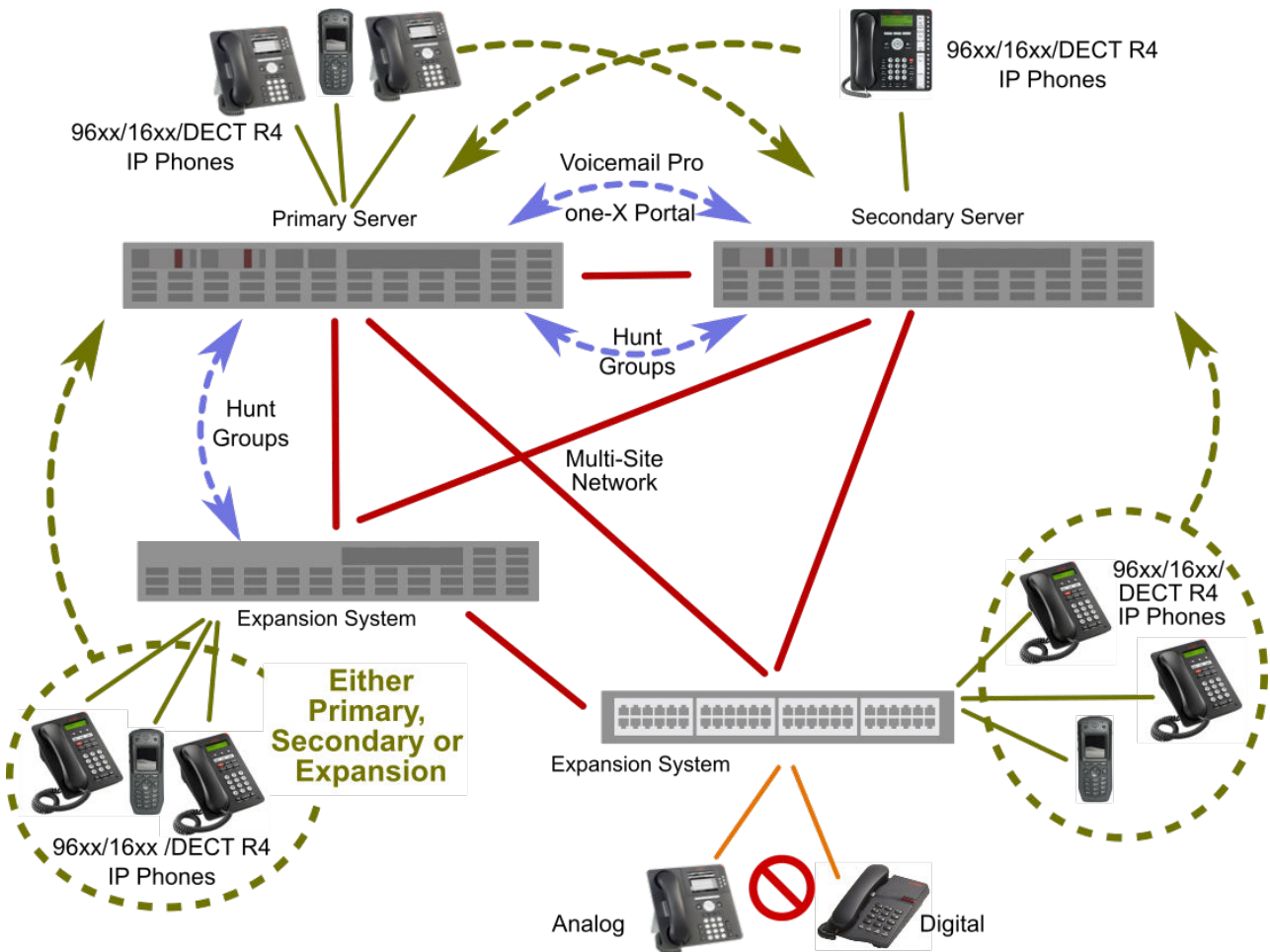

Figure 3: Resiliency Architecture

### Resilient management

You can continue to administer and manage the failure of IP Office Server Edition server and devices in an IP Office Server Edition Solution network through the Server Edition Secondary Server. This provides management without the offline capability, and a facility to realign the configuration after the outages have been resolved. The resynchronization feature highlights the time and source of configuration change and enables the administrator to decide which change set to retain. In addition, you can directly manage each device and application to allow configuration whilst isolated. You can use the resynchronization capability to realign the configurations after the devices are reconnected.

## Voicemail Pro Resiliency

### One Active Voicemail Pro server

Server Edition supports one active Voicemail Pro server on the Server Edition Primary server. A backup Voicemail Pro server is supported on the Server Edition Secondary server for resiliency.

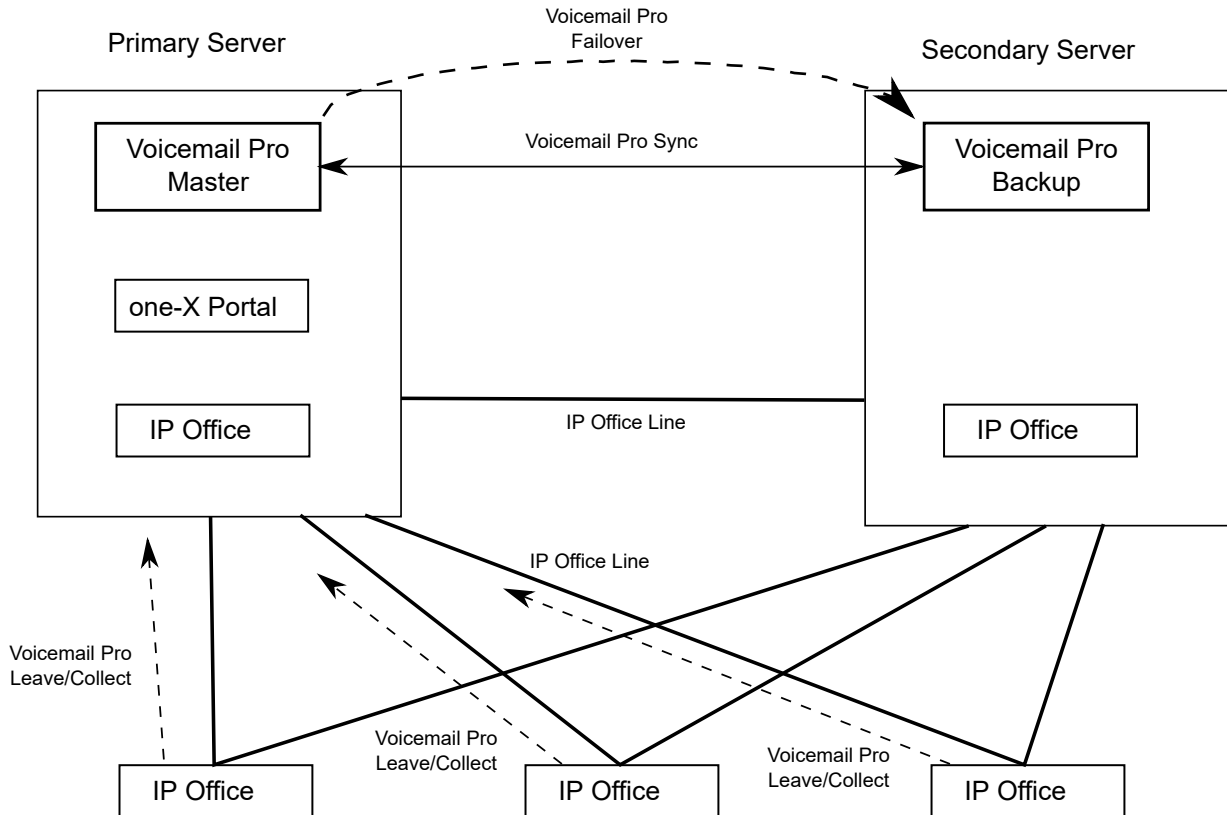

**Figure 4: One active Voicemail Pro server**

**Dual Active Voicemail Pro servers**

Server Edition deployments with Select licensing support two active Voicemail Pro servers, doubling the maximum channel capacity and dual processing locations. Each expansion system and all contained users can be configured to use one or the other. Each Voicemail Pro server provides backup for the other. The two Voicemail Pro servers are both active for a configured subset of users. They share a common configuration and message store. Each can support all mailboxes, message waiting indicators (MWI) and call flows under failure conditions.

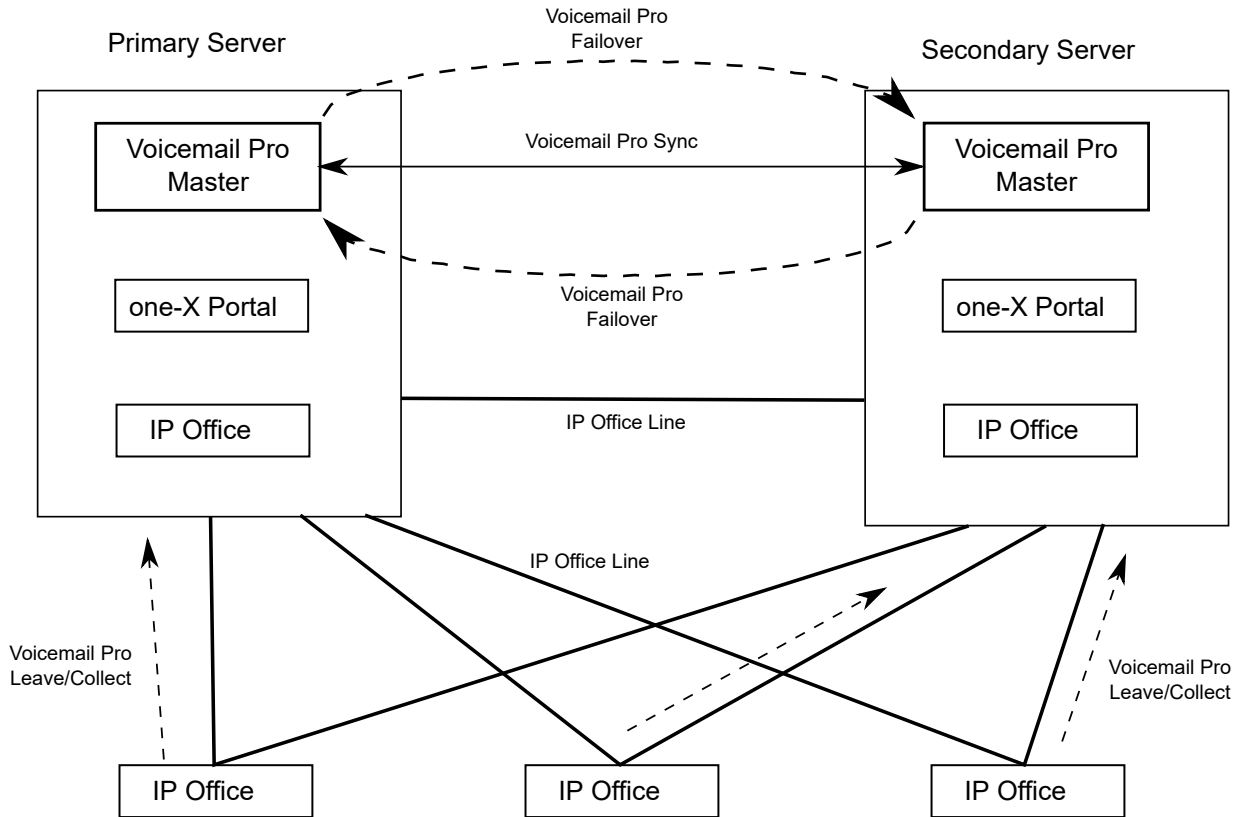

**Figure 5: Dual Active Voicemail Pro servers**

### Supported Configurations

The following configuration are supported.

- Dual Voicemail Pro, each acting as a backup
- Dual Voicemail Pro, no backup operation
- Single master Voicemail Pro on Primary, no backup (non-Select)
- Single master Voicemail Pro on Primary and backup on Secondary (non-Select)
- Single master Voicemail Pro on Secondary and backup on Primary

### Related links

[Server Edition Resiliency](#) on page 746

## Avaya one-X<sup>®</sup> Portal resiliency

Server Edition Select deployments support a backup Avaya one-X<sup>®</sup> Portal server, providing resiliency for Unified Communication (UC) features. The resilient one-X Portal server is installed by default on the Server Edition Secondary server. Resilient one-X Portal servers can also be located on standalone application servers.

### Resilient one-X Portal on the Server Edition Primary and Server Edition Secondary Servers

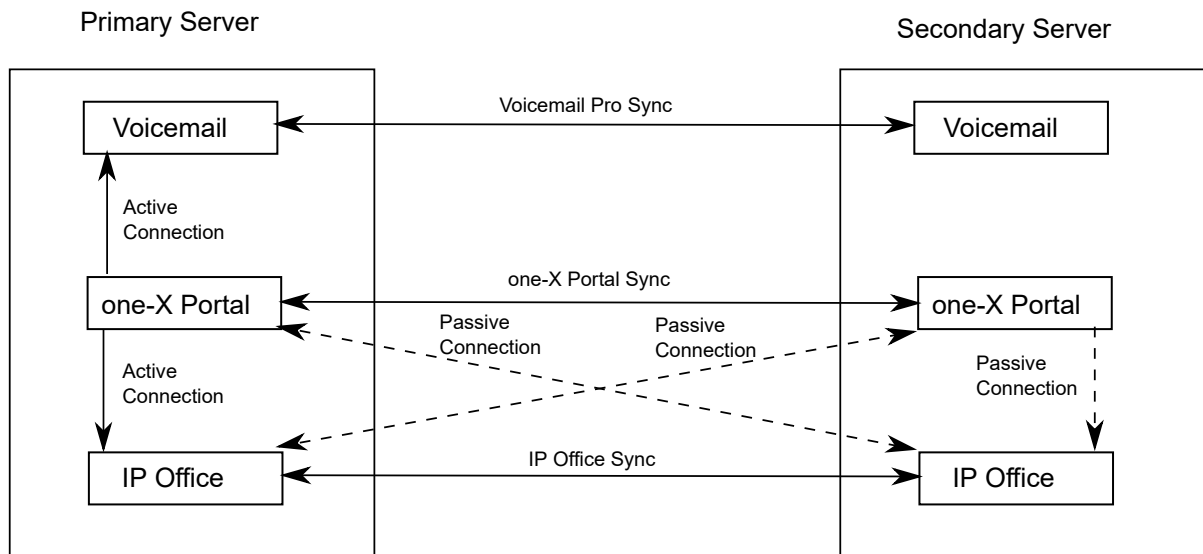

### Resilient Avaya one-X® Portal on Standalone Application Servers

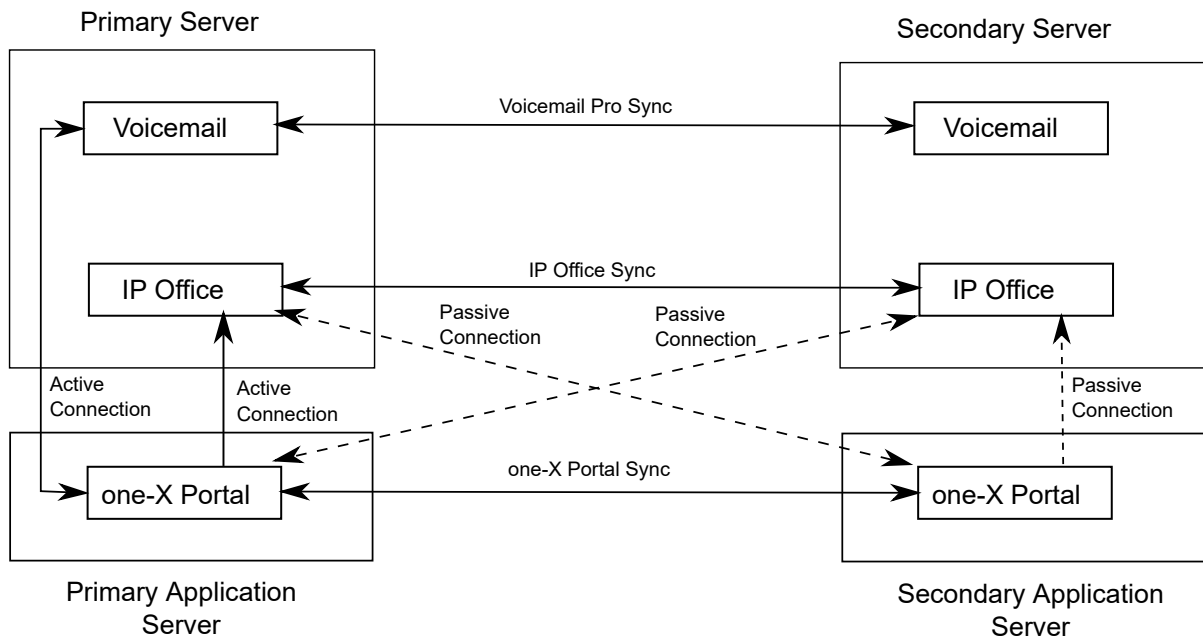

### Avaya one-X® Portal Failover and Failback

When the primary Avaya one-X® Portal server is not available, failover occurs and the backup server becomes active. Clients automatically recognize that the primary Avaya one-X® Portal

server is not available and log in to the backup server. Logged in users are automatically logged in to the backup Avaya one-X<sup>®</sup> Portal server.

When the primary Avaya one-X<sup>®</sup> Portal server is once again available, users automatically failback to it. The backup Avaya one-X<sup>®</sup> Portal server redirects login requests to the primary Avaya one-X<sup>®</sup> Portal server.

If connectivity between the primary and backup Avaya one-X<sup>®</sup> Portal servers is lost for an extended time, both Avaya one-X<sup>®</sup> Portal servers become active and accept login requests. Once connectivity is reestablished, the two servers are synchronized and all users are logged in to the primary one-X Portal server.

**\* Note:**

When both Avaya one-X<sup>®</sup> Portal servers are active, any changes made by users logged in to the backup server will be lost when failback occurs.

### **one-X Portal Resiliency with IP Office and Voicemail Pro**

If the Voicemail Pro server on the Server Edition Primary server is not available, the primary Avaya one-X<sup>®</sup> Portal server fails over to the Voicemail Pro server on the Server Edition Secondary server. When the Voicemail Pro server on the Server Edition Primary server is once again available, the primary Avaya one-X<sup>®</sup> Portal server automatically performs a failback to the Voicemail Pro server on the Server Edition Primary server.

#### **Related links**

[Server Edition Resiliency](#) on page 746

---

## **Phone Resiliency**

### **Phone Failover**

When phone resiliency is configured, the home system shares information about the registered phones and users on those phones with the backup system. If the home system is no longer visible to the phones, failover occurs and the phones register with the backup system.

### **Phone Failback**

If the phone's home system has been up for more than 10 minutes, the system causes idle phones to perform a failback to the home system. If the phone is unable to connect to the home system, there is a five minute grace period, referred to as homeless prevention, where the phone can be logged in to either the home or backup system.

Automatic failback to the home system is the default mode. Failback can be configured to operate manually. This may be desired if for example, the home system will be unavailable for some time. In manual mode, failback does not occur until the phone has been logged out or rebooted.

**\* Note:**

Manual failback is not supported for SIP phones.



## Configuration Options

Resiliency is configured on **IP Office Line > Line** under **SCN Resiliency Options**. The options are:

- **Backs up my IP Phones**
- **Backs up my Hunt Groups**
- **Backs up my Voicemail**
- **Backs up my IP DECT Phones**
- **Backs up my one-X Portal**

## Notes on Phone Resiliency Behavior

- Failover handover takes a minimum of 3 minutes (longer for larger networks). This ensures that failover is not invoked when it is not required; for example, when the home system is simply being rebooted to complete a non-mergeable configuration change.
- Failover is only intended to provide basic call functionality while the cause of failover occurring is investigated and resolved. If users make changes to their settings while in failover, for example changing their DND mode, those changes will not apply after failback.
- Calls anchored on the home system lose all voice paths during failover. Direct media calls in a stable state might maintain voice paths until the next call event, but this is not guaranteed.

Media preservation is not supported on SIP phones.

- If the failover system is rebooted while it is providing failover services, the failover services are lost.
- Failover features require that the phones local to each system are still able to route data to the backup system when the home system is not available. This will typically require each system site to be using a separate data router.
- When an IP phone fails over, the backup system allows it to operate indefinitely as a “guest”, but only until the system resets. Licenses will never be consumed for a guest phone.
- Hot desking users are automatically logged out. When their base extension fails back to the home system, the user is automatically logged in on their base extension.
- The media security configuration should be the same on all systems. For example, if an extensions home system is set to **Best Effort**, the failover system should also be set to **Best Effort**.
- For secure communication using TLS/SRTP, all IP Office systems must have an identity certificate that has been signed by the same trusted root CA.

### **Note:**

- Authentication of the client's certificate by the server is not a requirement. IP Office does not support client certificate validation for all SIP endpoint types.
- Failover provides only basic call functionality for Avaya Workplace Client and call logs generated while connected to the backup server will not be available after failback.
- The primary and secondary servers should have the same configurations of Avaya cloud account authorization. If Avaya cloud account authorization is enabled on primary server and you have logged in with Avaya cloud account authorization, use the same login in secondary server during failover.

## Supported Network Configurations

Phone resiliency is supported between any IP Office systems linked through an IP Office Line with **Networking Level** set to **SCN**. This includes failover from an IP500V2/IP500V2A system to another IP500V2/IP500V2A system.

For Server Edition deployments, failover from one node to any other node in the solution is supported.

Resiliency can be configured by specifying a **Location** with a unique IP address for the backup system.

## Supported Phones

Phone resiliency is supported on the phones listed below. Each IP Office system can be the initial or backup system for a mixture of resilient phone types.

### H.323 Phones:

- Resiliency is supported on 1600 and 9600 series phones.

### SIP Phones:

The following SIP phones are supported:

- 1120
- 1140
- 1220
- 1230
- E129
- J129
- J139
- J159
- J169
- J179
- J189
- B179
- B199
- H175
- K165 for Vantage 2.2
- K175
- K155

### SIP Soft Clients:

The following SIP soft clients are supported. Note that for these client, resiliency is also dependent on Avaya one-X<sup>®</sup> Portalresilience.

- Avaya Workplace Client for Windows

- one-X Mobile Preferred for Android
- one-X Mobile Preferred for iOS

**\* Note:**

Resiliency is not supported for:

- Avaya Lync Plug-in
- IP Office SoftConsole

**Notes on Supported Phones:**

- E129, 1100 Series, 1200 Series, B179, B199, and Avaya Workplace Client for Windows always attempt to register to multiple servers. The homeless prevention feature is not applicable to these phones.
- The B179 phone does not have a configuration file setting for the backup system. You must use the phone web interface to configure the **Secondary SIP Server** setting and the **Fallback Account** settings.
- For SIP phone resiliency, all IP Office systems in the Server Edition solution or SCN cluster must have the same **System > LAN > VoIP > SIP Domain** setting.

The **SIP Domain** is not the same as the IP Office fully qualified domain name (FQDN). They are not synonymous but can be related through DNS SRV A records. A single SIP Domain can include multiple SIP servers.

- On Avaya Workplace Client, the **System > LAN > VoIP > SIP Domain** value must be configured in the **Domain name** field under **Settings**.
- Remote worker SIP phones will not failover when the failover server is CPE and their home system is cloud based.
- B199 is not supported in Avaya Session Border Controller for Enterprise (ASBCE) remote worker and with Branch deployments.

**Related links**

[Server Edition Resiliency](#) on page 746

---

## Configuring Resiliency

**Related links**

[Server Edition Resiliency](#) on page 746

## Configuring Resiliency Using the Resiliency Administration Tool

This process adjusts the settings of the IP Office lines between systems to indicate which lines are being used to give/receive fallback options and what fallback options.

**\* Note:**

You can activate the resilience for an expansion system either on a primary server or a secondary server only. You cannot activate the resilience for an expansion system on both the primary server and secondary server.

## Procedure

1. In the Server Edition Solution View, select the **Resilience Administration** link on the right.
2. The **Resiliency Administration** page opens.

Select the options required.

- **Backup Primary Server IP Phones, Hunt Groups, Voicemail and one-X Portal on Secondary Server** When selected, the Secondary Server will support hunt group operation during any failure of the Primary Server. Also when selected, the Secondary Server will support the continued operation of Avaya IP phones normally registered to the Primary Server.
  - **Backup Secondary Server IP Phones on Primary Server** When selected, the Primary Server will support the continued operation of Avaya IP phones normally registered to the Secondary Server.
  - **Backup Expansion Systems**
    - For each expansion system, you can select to **Backup Phones** and **Backup Hunt Groups** by clicking the check boxes.
    - In the **Resilient To** field, select the IP Office system that will act as the backup.
3. Click **OK**.

## Linking Server Edition Expansion Systems

You can link Server Edition Select expansion systems with an IP Office Line in order to enable resiliency capability. When you link expansion systems using the Link Expansions tool, an IP Office Line is configured with default settings. You must select the security level for the line.

### Procedure

1. Open Manager and log in to the Primary Server.
2. On the Solution page, on the right hand side, click **Link Expansions**.
3. In the Link Expansions window, in the **First Expansion** field, select an expansion system from the list.
4. In the **Second Expansion** field, select an expansion system from the list.
5. Under **Select Link Type**, select one of the following options:
  - **SCN Websocket (Secure)**: Recommended for security and NAT traversal.
  - **SCN Websocket**: Supports NAT traversal with limited security.
  - **SCN**: Legacy SCN line. Not recommended for new deployment.
6. If the Link Type is set to **SCN Websocket (Secure)** or **SCN Websocket**, you must configure a password.

## Configuring Voicemail Pro Resiliency

Supported configurations are listed in the table below. A dual Voicemail Pro configuration is supported on Server Edition deployments with Select licensing.

Configuration Type	Voicemail IP Address on Primary	Backup Voicemail IP Address on Primary	Voicemail IP Address on Secondary	Backup Voicemail IP Address on Secondary
Dual Voicemail Pro, each acting as a backup	Primary Server IP Address	Secondary Server IP Address	Secondary Server IP Address	Primary Server IP Address
Dual Voicemail Pro, no backup operation	Primary Server IP Address		Secondary Server IP Address	
Single master Voicemail Pro on Primary, no backup [1]	Primary Server IP Address			
Single master Voicemail Pro on Primary and backup on Secondary [1]	Primary Server IP Address	Secondary Server IP Address		
Single master Voicemail Pro on Secondary and backup on Primary			Secondary Server IP Address	Primary Server IP Address

**Notes:**

1. Non-Select.
2. For resiliency operation, you must also ensure that the default SMTP Sender setting of the voicemail server is set to be the server's fully qualified domain name. Within the voicemail server preferences, select **System Preferences | Email | SMTP Sender**. The **Domain** and **Server** fields of the first entry must be set to the fully-qualified domain name of the voicemail server, not *local host*. This needs to be done on both the primary and secondary voicemail servers.

**Procedure**

1. Log in to Manager.
2. In the navigation pane on the left, open the Primary server configuration and select **System**.
3. In the details pane, select the **Voicemail** tab.
4. In the **Voicemail Type** field, select **Voicemail Lite/Pro**.
5. Set the **Voicemail IP Address** and **Backup Voicemail IP Address** as required based on the table above.
6. Repeat for the Secondary server configuration.

## Configuring one-X Portal Resiliency

Use this procedure to turn on one-X Portal Resiliency. Note that if resiliency is not turned on, the one-X Portal server on the Server Edition Secondary remains in a stopped state.

### Procedure

1. Log in to Manager.
2. In the navigation pane on the left, select the Primary Server configuration and click **Line**.
3. In the Group pane, select the **IP Office Line** connection to the Secondary Server.
4. On the **Line** tab, under **SCN Resiliency Options**, check the box **Supports Resiliency**.
5. Check the box **Backs up my one-X Portal**.
6. Repeat on the Secondary server for the **IP Office Line** connection to the Primary server.

### Next steps

You must configure resiliency on one-X Portal. See the section “Resilience” in *Administering Avaya one-X® Portal for IP Office™ Platform* .

## Configuring Phone Resiliency

### Procedure

1. Using Manager, log in to the backup system that phones will failover to.
2. In the navigation pane on the left, select **Line**.
3. In the group pane, select the IP Office Line that connects to the home system.  
In the details pane, the **Line** tab is displayed.
4. Under **SCN Resiliency Options**, check the box for **Supports Resiliency**.
5. Check the boxes for the desired resiliency options.

The options are:

- **Backup my IP phones** — Note that changes to the resilience destination for phones registered with the system are not picked up by those phones until they are restarted.
  - **Backup my Hunt Groups**
  - **Backup my Voicemail**
  - **Backup my IP DECT Phones**
6. If you are configuring resiliency for SIP phones.
    - a. Navigate to **System > LAN > VoIP > SIP Domain** and record the SIP domain value.
    - b. Log in to the home system for the resilient phones and navigate to **System > LAN > VoIP > SIP Domain**.
    - c. Ensure the values are the same on both systems.

## Configuring Manual Phone Failback

Automatic failback to the home system is the default mode. Failback can be configured to operate manually. This may be desired if for example, the home system will be unavailable for some time. In manual mode, failback does not occur until the phone has been logged out or rebooted.

### **Note:**

SIP endpoints do not support manual phone failback.

### **Procedure**

1. Using Manager, log in to the home system for the resilient phones.
2. In the navigation pane on the left, select **System**.
3. In the details pane, click the **Telephony** tab.  
The **Telephony | Telephony** tab is displayed.
4. In the **Phone Failback** field, select **Manual**.

## Configuring Location Based Extension Resiliency

Server Edition Select location based resiliency allows you to create a group of extensions by applying a common **Location** value to each extension. You can then specify the fallback IP Office server for the group. The location based fallback overrides the system fallback configuration. Using location based resiliency

- Phones on the Primary and Secondary server can fall back to an Expansion system
- Phones on an Expansion system can fall back to another Expansion system

Location based resiliency is supported on Avaya 1600 and 9600 series phones and all SIP endpoints.

### **Procedure**

1. In Manager, open the **Location** page and define a location for the phone group.
2. If the phone group is in a remote location, you can define the **Time Settings** for the group.
3. In the **Fallback System** field, select the system where the phone group will fall back to.

Note that the **Fallback System** list only contains systems where an IP Office Line has been configured.

4. Save the location.
5. For all phones that will be part of the group, open the extension page for the phone and select the new **Location**.  
Note that you can also set an IP address and subnet mask at the location level to match the phone IP addresses.
6. On the system where the extension is configured, open the **Line | IP Office Line** page.
7. Under **SCN Resiliency Options**, enable **Supports Resiliency**.

---

## Synchronizing the Configurations

### About this task

Normally during configuration of the Server Edition solution, records that are shared (Incoming Call Route, Time Profile, Account Code and User Rights) are automatically synchronized with the configuration of the individual servers as they are edited. However, when new servers are added to the network or systems have their configuration individually edited, it is possible that some share records may become out of synch with the Primary Server. This process can be used to re-establish the correct shared records.

Synchronizing the Configurations

### Procedure

1. In the Server Edition Solution View, right-click on **Solution**.
2. Select **Synchronize Configurations**.
3. Select **Yes** to confirm the removal.

---

## Starting Web Control

### About this task

Web control is the term used for a set of web based administration menus used by Linux based servers. That includes the Primary Server, Secondary Server and Expansion System (L) in a Server Edition solution. The menus provide functions such as stopping and starting individual services being run by the server. The menus for the Primary Server provide special network functions such as backing up and upgrading the whole network.

### Procedure

1. In the Server Edition Solution View, select the system for which you want to display its web control menus.  
The option is not available for Expansion System (V2).
2. Click on the  **Web Control** link on the right-hand edge of the menu.
3. The PC's default web browser is started with the address to the system.
4. When the login menu is displayed, login using the same configuration name and password as used for Manager configuration access.



# Chapter 15: Configuring SIP Trunks

## Related links

[Overview](#) on page 761

[Configuring a SIP Trunk](#) on page 762

[SIP Line Requirements](#) on page 763

[SIP Incoming Call Routing](#) on page 765

[SIP Prefix Operation](#) on page 766

[SIP messaging](#) on page 767

[IP Office SIP trunk specifications](#) on page 781

---

## Overview

A growing number of service providers now offer PSTN access to businesses via public SIP trunk connections, either to extend their reach beyond their typical copper based network coverage areas, or so that multiple services (voice and internet access) can be bundled into a single network connection. Although detailed public SIP trunk service offerings vary depending on the exact nature of the offer from the specific service provider, SIP trunks can potentially provide several advantages compared to traditional analog or digital trunks. These advantages include:

- cost savings resulting from reduced long distance charges, more efficient allocation of trunks, and operational savings associated with managing a consolidated network
- simplified dialing plans and number portability
- geographic transparency for local accessibility creating a virtual presence for incoming calls
- trunk diversity and redundancy
- multi-media ready to roll out future SIP enabled applications
- fewer hardware interfaces to purchase and manage, reducing cost and complexity
- faster and easier provisioning

IP Office delivers functionality that enhances its ability to be deployed in multi-vendor SIP-based VoIP networks. While this functionality is primarily based on the evolving SIP standards, there is no guarantee that all vendors, interpret and implement the standards in the same way. To help the SIP service provider, Avaya operates a comprehensive SIP Compliance Testing Program referred to as GSSCP. Avaya's DevConnect program validates the operation of the IP Office solution with the service provider's SIP trunk offering.

## Related links

[Configuring SIP Trunks](#) on page 761

---

# Configuring a SIP Trunk

This procedure provides the basic steps for configuring a SIP trunk between two IP Office systems.

## Before you begin

- You must know the IP address of both ends of the trunk.
- You must have valid licenses on both IP Office systems.
- On Server Edition, make sure you have a non-zero value in the **SIP Trunk Sessions** field on the **License | Remote Server** tab. If you do not, you will see Monitor messages about insufficient licenses.

## Procedure

1. In the Manager navigation pane, right click **Line** and select **New > SIP Line**.
2. Record the **Line Number** value that appears on the SIP Line page for use later.
3. In the **ITSP Domain Name** field, enter the domain name required by the far end.  
If nothing is configured in this field, then IP Office inserts the far end's **ITSP Proxy Address** from the **Transport** tab as the ITSP domain in the SIP messaging.
4. Use the default values for the remaining fields.
5. Select the **Transport** tab.
6. In the **ITSP Proxy Address** field, enter the IP Address of the far end.
7. Select the **SIP URI** tab.
8. Click **Add**.
9. Enter values for the **Incoming Group** and **Outgoing Group** fields.  
You can use the **Line Number** from the **SIP Line** tab for both values.
10. In the Manager navigation page, select **Incoming Call Route**.
11. On the **Standard** tab, in the **Line Group ID** field, enter the **Line Number** from the **SIP Line** tab.
12. Select the **Destinations** tab.
13. In the **Destination** column, replace the value with a period (".").
14. In the Manager navigation pane, select **Short Code**.
15. Add a short code to dial the trunk you have just added.
16. One end of the trunk is now configured. Save the configuration to the IP Office.

17. Using Manager, open the configuration for the IP Office at the other end of the SIP trunk and repeat the steps.

### Related links

[Configuring SIP Trunks](#) on page 761

---

## SIP Line Requirements

Use of SIP requires the following:

- **SIP Service Account** An account or accounts with a SIP internet service provider (ITSP). The method of operation and the information provided will vary. The key requirement is a SIP URI, a web address of the form **name@example.com**. This is the equivalent of a SIP telephone number for making and receiving calls via SIP.
- **Voice Compression Channels** SIP calls use system voice compression channels in the same way as used for standard IP trunks and extensions. For an IP500 V2 system, these are provided by the installation of VCM modules within the control unit. RTP relay is applied to SIP calls where applicable.
- **Licensing** SIP trunks require licenses in the system configuration. These set the maximum number of simultaneous SIP calls supported by the system.
- **Firewall Traversal** Routing traditional H.323 VoIP calls through firewalls often fails due to the effects of NAT (Network Address Translation). For SIP a number of ways to ensure successful firewall traversal can be used. The system does not apply any firewall between LAN1 and LAN2 to SIP calls.
  - **STUN (Simple Traverse of UDP NAT)** UDP SIP can use a mechanism called STUN to cross firewalls between the switch and the ITSP. This requires the ITSP to provide the IP address of their STUN server and the system to then select from various STUN methods how to connect to that server. The system can attempt to auto-detect the required settings to successfully connect. To use STUN, the line must be linked to the Network Topology settings of a LAN interface using the line's Use Network Topology Info setting.
  - **TURN (Traversal Using Relay NAT)** TCP SIP can use a mechanism called TURN (Traversal Using Relay NAT). This is not currently supported.
  - **Session Border Control** STUN does not have to be used for NAT traversal when SBC is between IP Office and the ITSP, since the SBCE will be performing NAT traversal.
- **SIP Trunks** These trunks are manually added to the system configuration. Typically a SIP trunk is required for each SIP ITSP being used. The configuration provides methods for multiple URI's from that ITSP to use the same trunk. For each trunk at least one SIP URI entry is required, up to 150 SIP URI's are supported on the same trunk. Amongst other things this sets the incoming and outgoing groups for call routing.
- **Outgoing Call Routing** The initial routing uses any standard short code with a dial feature. The short code's Line Group ID should be set to match the Outgoing Group ID of the SIP URI channels to use. However the short code must also change the number dialed into a

destination SIP URI suitable for routing by the ITSP. In most cases, if the destination is a public telephone network number, a URI of the form **123456789@example.com** is suitable. For example:

- **Code:** 9N#
- **Feature:** Dial
- **Telephone Number:** N"@example.com"
- **Line Group ID:** 100

While this can be done in the short code, it is not an absolute necessity. The ITSP Proxy Address or ITSP Domain Name will be used as the host/domain part.

- **Incoming Call Routing** Incoming SIP calls are routed in the same way as other incoming external calls. The caller and called information in the SIP call header can be used to match Incoming CLI and Incoming Number settings in normal system Incoming Call Route records.
- **DiffServ Marking** DiffServ marking is applied to calls using the DiffServer Settings on the System | LAN | VoIP tab of the LAN interface as set by the line's **Use Network Topology Info** setting.

### SIP URIs

Calls across SIP require URI's (Uniform Resource Identifiers), one for the source and one for the destination. Each SIP URI consists of two parts, the user part (for example **name**) and the domain part (for example **example.com**) to form a full URI (in this case **name@example.com**). SIP URI's can take several forms:

- name@117.53.22.2
- name@example.com
- 012345678@example.com

Typically each account with a SIP service provider will include a SIP URI or a set of URI's. The domain part is then used for the SIP trunk configured for routing calls to that provider. The user part can be assigned either to an individual user if you have one URI per user for that ITSP, or it can also be configured against the line for use by all users who have calls routed via that line.

If the wildcard \* is used in the SIP trunk's **Local URI**, **Contact** and **Display** fields, that SIP trunk will accept any incoming SIP call. The incoming call routing is still performed by the system incoming call routes based on matching the values received with the call or the URI's incoming group setting. For outgoing calls using this SIP URI, all valid short code CLI manipulations are used (transforming calling party number to ISDN will be ignored). For a full list of valid CLI manipulations, see "Telephone Number Field Characters" under [Short Code Characters](#) on page 808. For example, character 'i' is not supported since it sets calling party number plan to isdn and number type to national.

### Resource Limitation

A number of limits can affect the number of SIP calls. When one of these limits is reached the following occurs: any further outgoing SIP calls are blocked unless some alternate route is available using ARS; any incoming SIP calls are queued until the required resource becomes available. Limiting factors are:

- the number of licensed SIP sessions.

- the number of SIP sessions configured for a SIP URI.
- the number of voice compression channels.
  - **SIP Line Call to/from Non-IP Devices** Voice compression channel required.
  - **Outgoing SIP Line Call from IP Device** No voice compression channel required.
  - **Incoming SIP Line Call to IP Device** If using the same codec, voice compression channel reserved until call connected. If using differing codecs then 2 channels used.

### SIP Information Display

The full from and to SIP URI will be recorded for use by SMDR, CBC and CCC. For all other applications and for telephone devices, the SIP URI is put through system directory matching the same as for incoming CLI matching. First a match against the full URI is attempted, then a match against the user part of the URI. Directory wildcards can also be used for the URI matching.

### Related links

[Configuring SIP Trunks](#) on page 761

---

## SIP Incoming Call Routing

Incoming SIP calls are routed using Incoming Call Routes in the same way as call arriving on other external trunks. The following **Incoming Call Route** fields are used to determine which route is the best match for a call.

**Line Group ID** This field is matched against the Incoming Group settings of the SIP URI (Line | SIP URI). This must be an exact match.

**Incoming Number** This field can be used to match the called details (TO) in the SIP header of incoming calls. It can contain a number, SIP URI or Tel URI. For SIP URI's the domain part of the URI is removed before matching by incoming call routing occurs. For example, for the SIP URI mysip@example.com , only the user part of the URI, ie. mysip, is used for matching.

**Incoming CLI** This field can be used to match the calling details (FROM) in the SDP header of incoming SIP calls. It can contain a number, SIP URI, Tel URI or IP address received with SIP calls. For all types of incoming CLI except IP addresses, a partial entry can be used to achieve the match, records being read from left to right. For IP addresses only full entry matching is supported.

The fields **Bearer Capability** and **Incoming Sub Address** are not used for matching of incoming SIP calls. The remaining **Incoming Call Route** fields, including those on the **Voice Recording** page, are used as for all call types..

If the wildcard \* is used in the SIP trunk's **Local URI**, **Contact** and **Display** fields, that SIP trunk will accept any incoming SIP call. The incoming call routing is still performed by the system incoming call routes based on matching the values received with the call or the URI's incoming group setting. For outgoing calls using this SIP URI, all valid short code CLI manipulations are used (transforming calling party number to ISDN will be ignored). For a full list of valid CLI manipulations, see "Telephone Number Field Characters" under [Short Code Characters](#) on page 808. For example, character 'i' is not supported since it sets calling party number plan to isdn and number type to national.

**Related links**

[Configuring SIP Trunks](#) on page 761

## SIP Prefix Operation

The prefix fields **Prefix**, **National Prefix**, **Country Code** and **International Prefix** are available with the SIP Line settings. These fields are used in the following order:

1. If an incoming number (called or calling) starts with the + symbol, the + is replaced with the **International Prefix**.
2. If the **Country Code** has been set and an incoming number begins with that **Country Code** or with the **International Prefix** and **Country Code**, they are replaced with the **National Prefix**.
3. If the **Country Code** has been set and the incoming number does not start with the **National Prefix** or **International Prefix**, the **International Prefix** is added.
4. If the incoming number does not begin with either the **National Prefix** or **International Prefix**, then the **Prefix** is added.

For example, if the SIP Line is configured with prefixes as follows:

- **Prefix:** 9
- **National Prefix:** 90
- **International Prefix:** 900
- **Country Code:** 44

Number Received	Processing	Resulting Number
<b>+441707362200</b>	Following rule 1 above, the + is replace with the <b>International Prefix</b> (900), resulting in 900441707362200.  The number now matches the <b>International Prefix</b> (900) and <b>Country Code</b> (44).Following rule 2 above they are replace with the <b>National Prefix</b> (90).	<b>901707362200</b>
<b>00441707362200</b>	Following rule 2 above the <b>International Prefix</b> (900) and the <b>Country Code</b> (44) are replaced with the <b>National Prefix</b> (90).	<b>90107362200</b>
<b>441707362200</b>	Following rule 2 above, the <b>Country Code</b> (44) is replace with the <b>National Prefix</b> (90).	<b>901707362200</b>

*Table continues...*

Number Received	Processing	Resulting Number
6494770557	Following rule 3 above the <b>International Prefix</b> (900) is added.	9006494770557

## OPTIONS Operation

Options are not sent only when active SIP registration is present. In all other cases, OPTIONS are sent.

The interval is determined as by the No User source number **SIP\_OPTIONS\_PERIOD=X** as follows.

- If no **SIP\_OPTIONS\_PERIOD** parameter is defined and the **LAN1 | Network Topology | Binding Refresh Time** is 0, then the default value of 300 seconds is used.
- To establish a period less than 300 seconds, do not define a **SIP\_OPTIONS\_PERIOD** parameter and set the **Binding Refresh Time** to a value less than 300 seconds. The OPTIONS message period will be equal to the **Binding Refresh Time**.
- To establish a period greater than 300 seconds, a **SIP\_OPTIONS\_PERIOD** parameter must be defined. The **Binding Refresh Time** must be set to a value greater than 300 seconds. The OPTIONS message period will be the smaller of the **Binding Refresh Time** and the **SIP\_OPTIONS\_PERIOD**.

### Related links

[Configuring SIP Trunks](#) on page 761

---

## SIP messaging

### SIP trunk prerequisites

Before any calls can be made, the system must have sufficient SIP trunk licenses for the maximum number of simultaneous SIP trunk calls expected.

On Server Edition systems, the **System | Telephony | Telephony | Maximum SIP Sessions** value must match the total number of SIP extension and trunk calls that can occur at the same time.

### Related links

[Configuring SIP Trunks](#) on page 761  
[Outgoing call message details](#) on page 768  
[Incoming call message details](#) on page 772  
[Codec selection](#) on page 777  
[DTMF transmission](#) on page 778  
[Fax over SIP](#) on page 778  
[Hold scenarios](#) on page 778  
[SIP REFER](#) on page 780

---

## Outgoing call message details

### Related links

- [SIP messaging](#) on page 767
- [Destination URI](#) on page 768
- [From field content](#) on page 768
- [To field content](#) on page 769
- [Contact field content](#) on page 769
- [P-Asserted Identity field content](#) on page 769
- [Typical outgoing call scenarios](#) on page 770

### Destination URI

The destination URI in an INVITE message has the general format of an e-mail address. Specific rules have been defined for expressing telephone numbers in this format. These rules are defined in RFC 2806 and RFC 3261 (section 19.1.6). A sample URI for a call on a SIP trunk is:

```
sip: 12125551234@ITSP_Domain SIP/2.0
```

The **ITSP\_Domain** in the following headers is taken from the **SIP Line | ITSP Domain Name** field. If that is empty, the IP Address of the IP Office LAN interface is used or the public address of that interface if topology discovery is used.

### Related links

- [Outgoing call message details](#) on page 768

### From field content

If the call is originated from an IP Office endpoint, the settings on the **SIP line | SIP URI** tab determine whether the information should be taken from the trunk's SIP credentials, or from the **User | SIP** tab.

- If the channel's Local URI is set to \* then the extension number is used for the User part of the identity.

```
From: "SipDisplayNameAlice" <sip: 311@ITSP_Domain>;tag=8a9fed65b
```

- If the channel's Local URI is set to 'Use Internal Data' then the **User | SIP | SIP Name** will be used for the User part of the identity, and the ITSP Domain for the host part.

```
From: "SipDisplayNameAlice" <sip: SipName@ITSP_Domain>;tag=8a9fed65b
```

- If the SIP Name field also contains a domain (indicated by the presence of @) then that domain will be used.

```
From: "SipDisplayNameAlice" <sip: SipName@USER_Domain>;tag=8a9fed65b
```

- If Call-ID is blocked either by short code or if the **User | SIP | Anonymous** checkbox is checked then the From: header will be anonymous, unless the **SIP Line | Send From in Clear** checkbox is checked.

```
From: "Anonymous" <sip:anonymous@anonymous.invalid>;tag=8a9fed65b
```



- If the channel's **Local URI** is set to **Use Credentials ...** then there must first be at least one set of SIP Credentials defined, and that account selected in the channel's **Registration** dropdown selection box. The corresponding field from the **SIP Line | SIP Credentials** tab will be used for the User part of the identity.

From: "Line17Cred2" <sip:Line17Cred2@ITSP\_Domain>;tag=8a9fed65b

- The contact identity is populated similarly to the **From:** header. If Call-Id blocking is invoked: via **W** in a short code, or by checking the **User | SIP | Anonymous** checkbox then the **Contact:** field becomes semi-anonymous:

Contact: <sip:anonymous@135.55.86.70:5060;transport=udp

### Related links

[Outgoing call message details](#) on page 768

## To field content

Since the identity of the called party is not known at the time of the initial INVITE, the **To:** field shows only the information necessary to route the call, which is the dialed digits after any short code and ARS manipulation, prefix manipulation, and removal of any end-of-dial digits (# in North America).

To: <sip: 12125551234@ITSP\_Domain>

### Related links

[Outgoing call message details](#) on page 768

## Contact field content

The contact identity is populated similarly to the **From:** header. If Call-Id blocking is invoked: via **W** in a short code, or by checking the **User | SIP | Anonymous** checkbox then the **Contact:** field becomes semi-anonymous:

Contact: <sip:anonymous@135.55.86.70:5060;transport=udp

### Related links

[Outgoing call message details](#) on page 768

## P-Asserted Identity field content

Without Call-Id blocking, this field essentially mirrors the **From:** field.

P-Asserted-Identity: " SipDisplayName " <sip: SipName@ITSP\_Domain>

### Note:

You can enter the wildcard character "\*". Entering this value populates the SIP PAI header with the caller information available to IP Office.

Call-Id blocking: using **W** in a short code, or by checking the **User | SIP | Anonymous** checkbox results in the **P-Asserted** field being the only header that carries the calling party information, and so is unchanged from the non-blocked case above.

P-Asserted-Identity: " SipDisplayName" <sip:SipName@ITSP\_Domain>

**Related links**

[Outgoing call message details](#) on page 768

**Typical outgoing call scenarios**

**INVITE with SDP, local ringback**

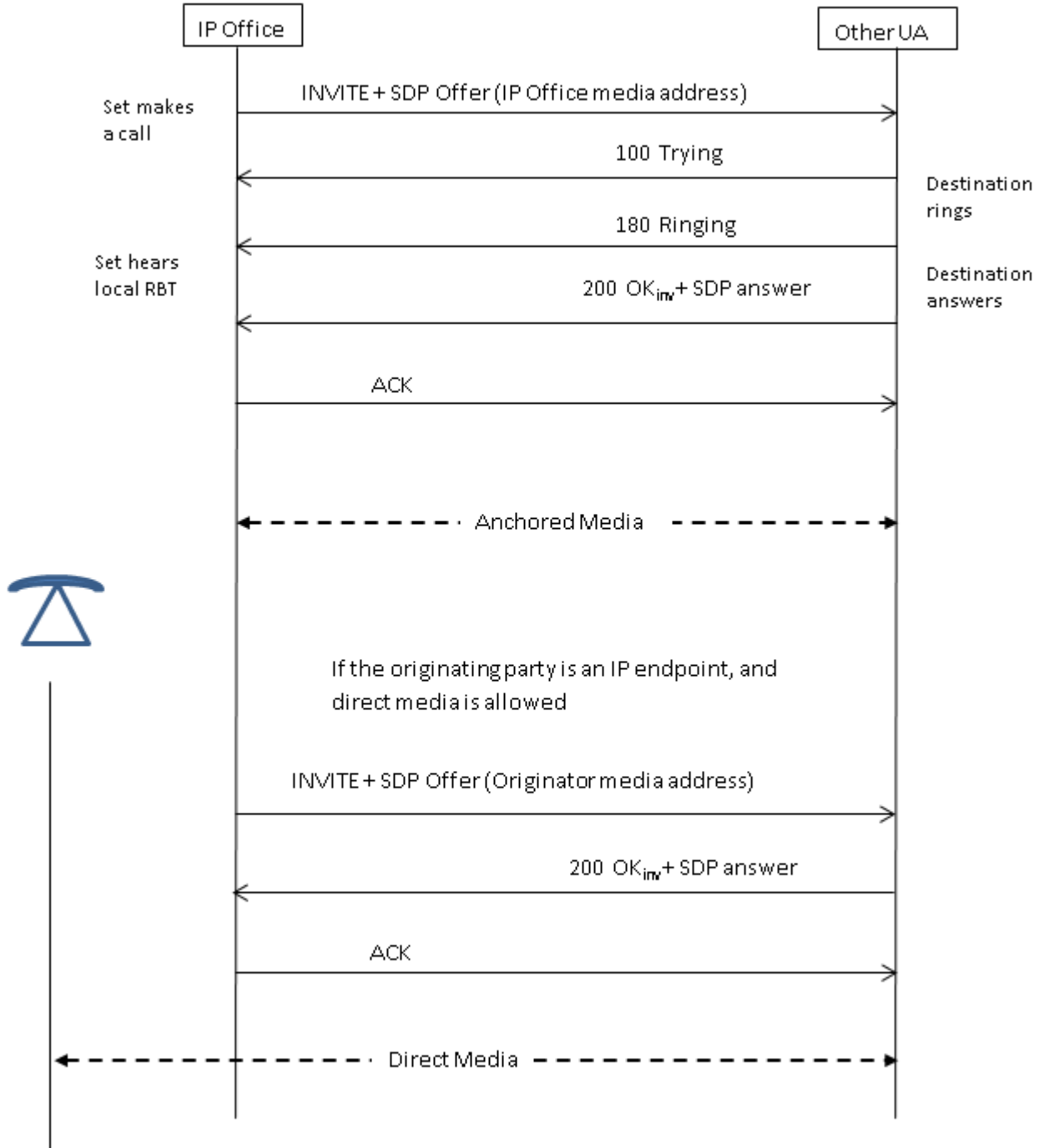

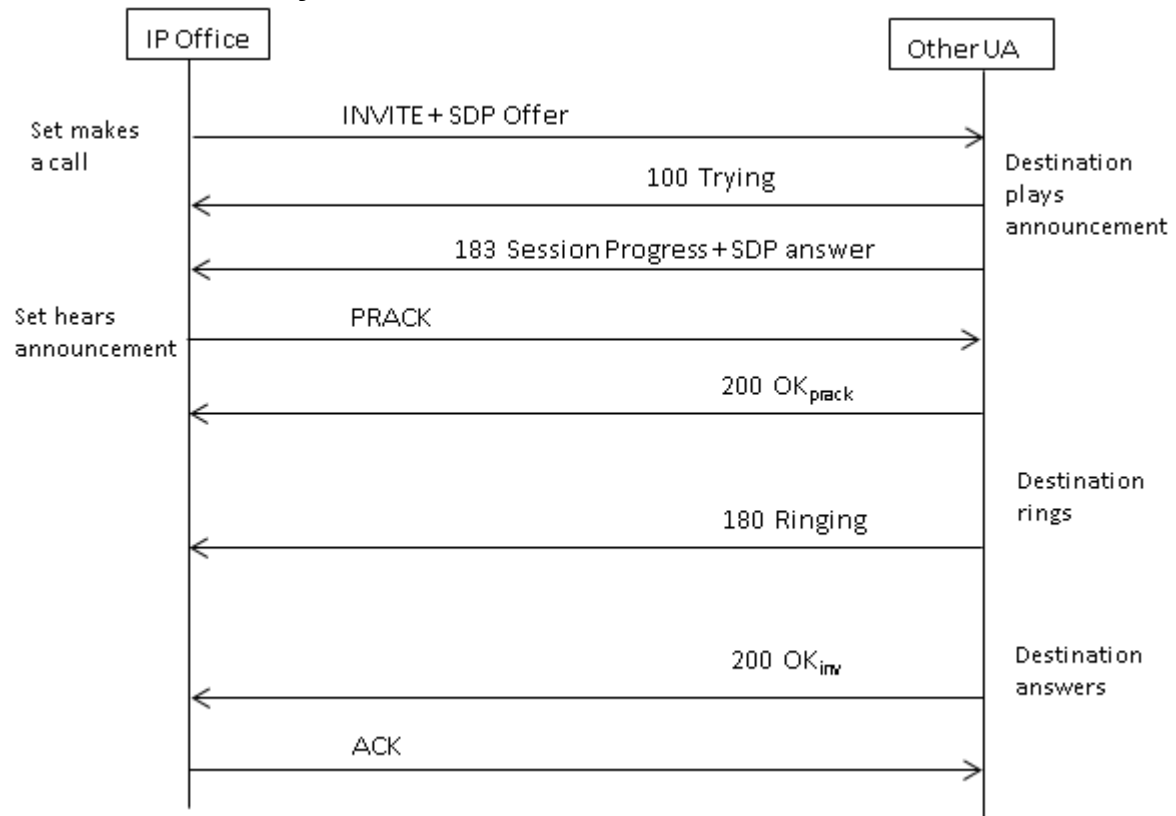
**INVITE with SDP, early media**

### INVITE with SDP, early media re-directed by destination

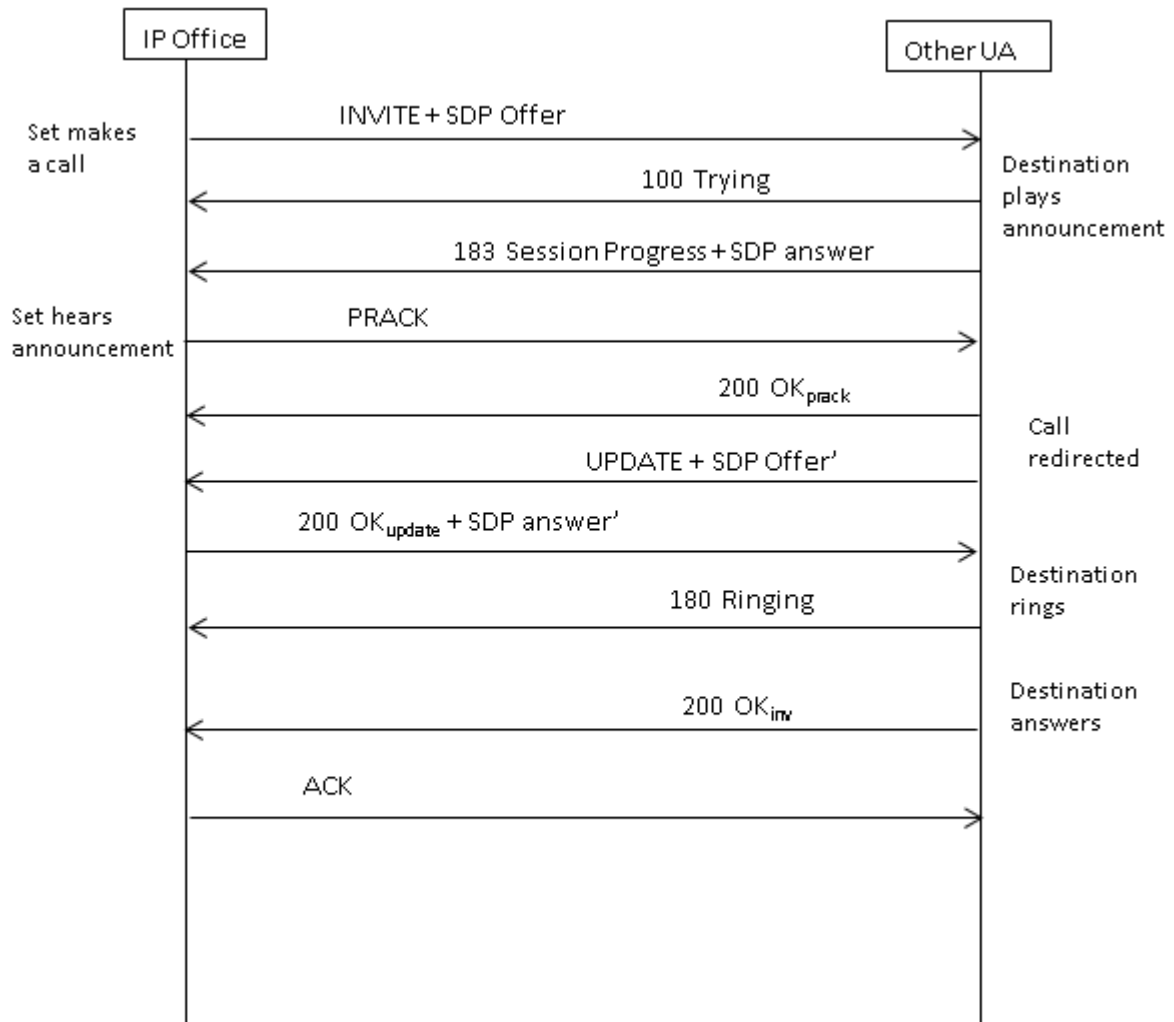

**Related links**

[Outgoing call message details](#) on page 768

## Incoming call message details

**Related links**

- [SIP messaging](#) on page 767
- [Incoming call routing](#) on page 772
- [Media path connection](#) on page 773
- [Typical incoming call scenarios](#) on page 774

## Incoming call routing

When a SIP INVITE is received by IP Office, its origin is compared to the known IP addresses of the SIP lines configured. If a match is not found, then the INVITE is presented internally to the

extension interface to determine if it matches any of the registered terminals. SIP messages from unknown endpoints are discarded, and solicit no response from IP Office.

SIP lines have incoming and outgoing groups associated with them, which are configured on the **SIP line | SIP URI** tab. In the example below, the incoming and outgoing groups are both 19, and the **Local URI** specifies **Use Internal Data**. With this **Local URI** setting, to route a call to a user, the **User | SIP | SIP Name** field is used to match against the incoming digits.

The screenshot displays the configuration for a SIP Line. On the left, a table lists various line types and subtypes. On the right, the 'SIP Line - Line 19' configuration page is shown, with the 'SIP URI' tab selected. Below the configuration table, the 'Edit Channel' section shows settings for the selected channel (1).

Line Number	Line Type	Line SubType
1	PRI 24 (Universal)	PRI
5	Analogue Trunk	
6	Analogue Trunk	
7	Analogue Trunk	
8	Analogue Trunk	
17	SIP Line	
18	SIP Line	
19	SIP Line	
20	SM Line	
22	SIP Line	
23	H323 Line	None
32	H323 Line	IP Office SCN
240	IP DECT	

Channel	Groups	Via	Local URI	Contact	Display Name	PAI	Credential	Max Calls
1	19 19	1...	Use Internal Data	Use Internal Data	Use Internal Data		0: <Non...	10

**Edit Channel**

Via: 135.55.86.71

Local URI: Use Internal Data

Contact: Use Internal Data

Display Name: Use Internal Data

The incoming group indicates the identity of an **Incoming Call Route**, which is used to match the incoming digits in the Request-URI to a target. That target could be an extension, a hunt group, another trunk, or an ARS entry.

Due to this grouping, calls incoming to several different trunks or trunk types can use the same **Incoming Call Route**, but in order for this to work, the **Local URI** must be manually set to <\*>.

**Incoming Call Routes** are identified by the **Line Group ID** or optionally, an **Incoming Number** may be specified to match against in the received digits. Then a **Destination** specified, which may be a specific target, or may contain only a <.> to indicate that the digits are to be matched against known system targets.

### Related links

[Incoming call message details](#) on page 772

## Media path connection

IP Office does not provide in-band ringback to incoming SIP trunk calls. This is different from what is done for H.323. The only scenario in which an incoming SIP trunk call will hear in-band ringback occurs when the call terminates on an analog trunk. With analog trunks, the media path is cut through immediately because IP Office has no way of determining the state (ringing, busy, answered) of the trunk.

IP Office connects “early” media before the call is answered by sending a 183 Session Progress response only if the following two conditions are met:

- A PROGRESS (in-band tone indication OR 183 Session Progress with SDP) message is received from the destination (this can only happen in a SIP-to-PRI or SIP-to-SIP tandem scenario).
- The INVITE message contains SDP.

IP Office does not attempt to connect early media on PROGRESS when there is no SDP in the initial INVITE, since this is unlikely to succeed. The reason there is no SDP in INVITE is probably that the originating system does not know the originator’s media address yet. A typical scenario where this is the case occurs when the call on the originating system comes from an H.323 SlowStart trunk.

**Related links**

[Incoming call message details](#) on page 772

**Typical incoming call scenarios**

**INVITE with SDP, local ringback**

If the destination is an analog trunk, the 180 Ringing will be replaced with a 183 Progress with SDP followed immediately by a “fake” answer in order that the media will be connected right away so that the originator hears whatever in-band tones are present on the analog trunk (ringback or busy). If the target is an extension that is unconditionally call forwarded over an analog trunk, then there will be a 180 Ringing without SDP, followed immediately by the “fake” answer.

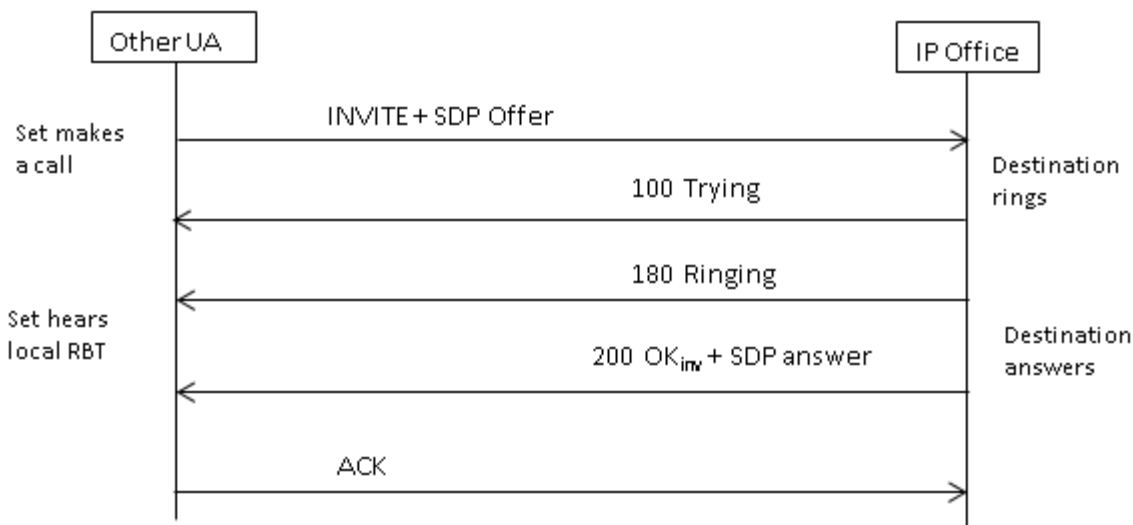

**INVITE with SDP, early media**

If the SIP Trunk receives a FAR\_PROGRESS (in-band) message from its peer in the core (e.g. from a tandem PRI or SIP trunk), it sends a 183 Session Progress message with SDP to the far end. IP Office will connect the media on receipt of 180 or 183 with SDP.

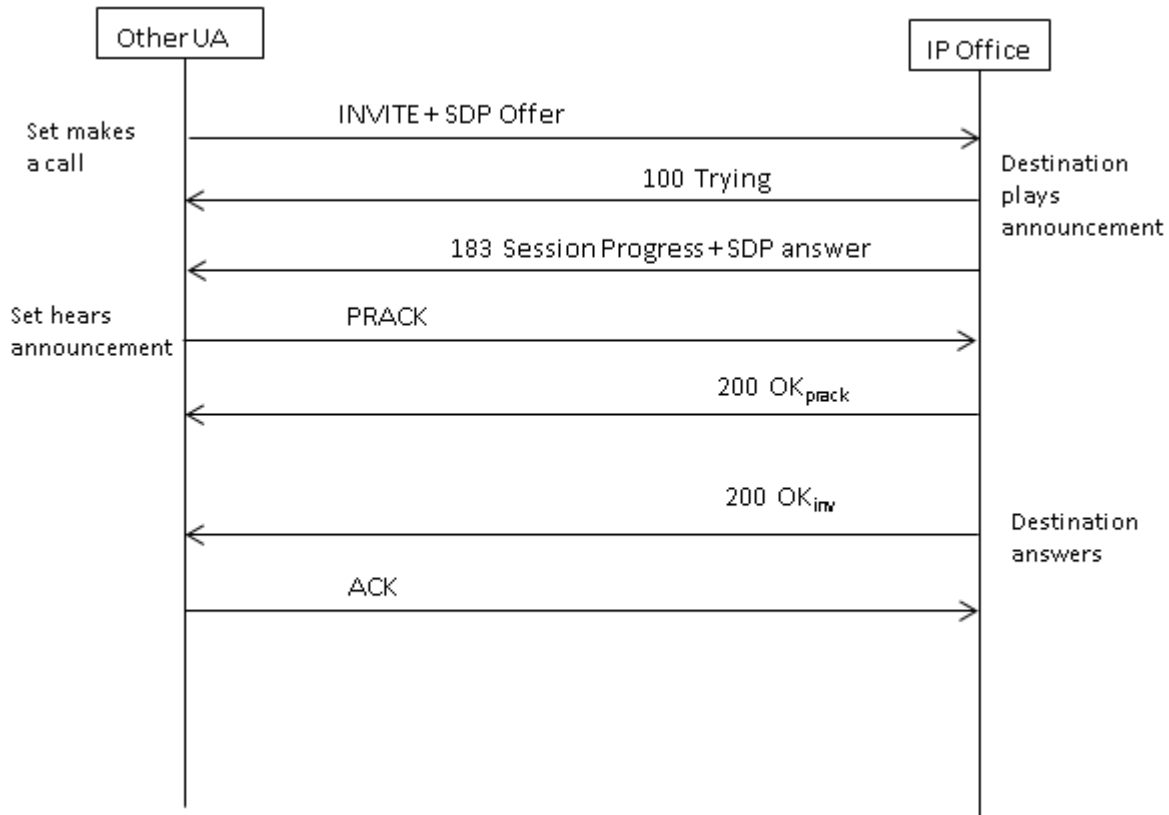

### INVITE without SDP, local ring back

IP Office does not attempt to send early media in this scenario.

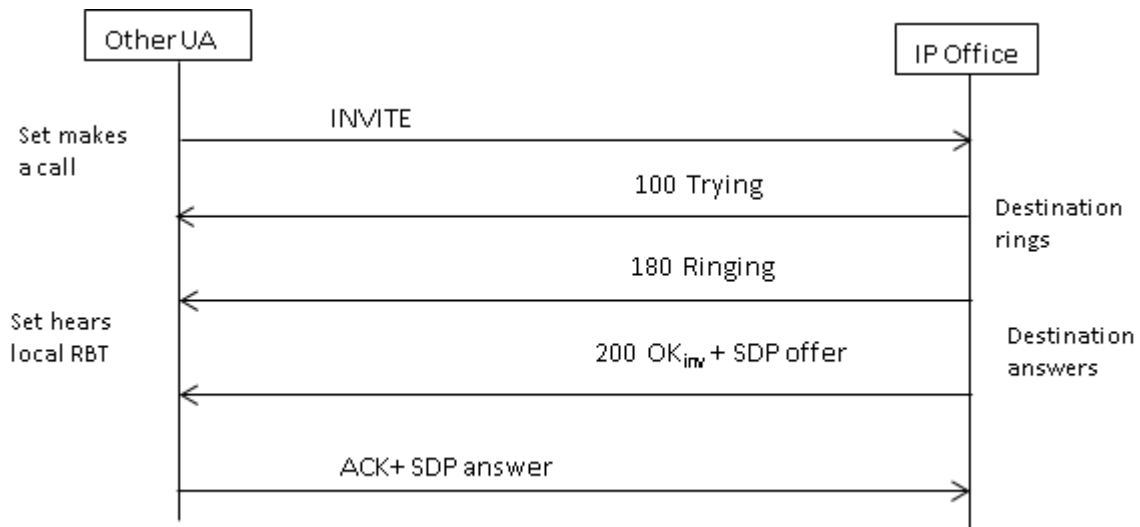

### INVITE without SDP, early media

In this scenario, the far end attempts to connect media before the call is answered. IP Office does not provide early media when receiving an empty INVITE, but rather 180 Ringing instead. There is

no requirement to provide an SDP in the 180 Ringing provisional response, as that response is not sent reliably using the PRACK mechanism.

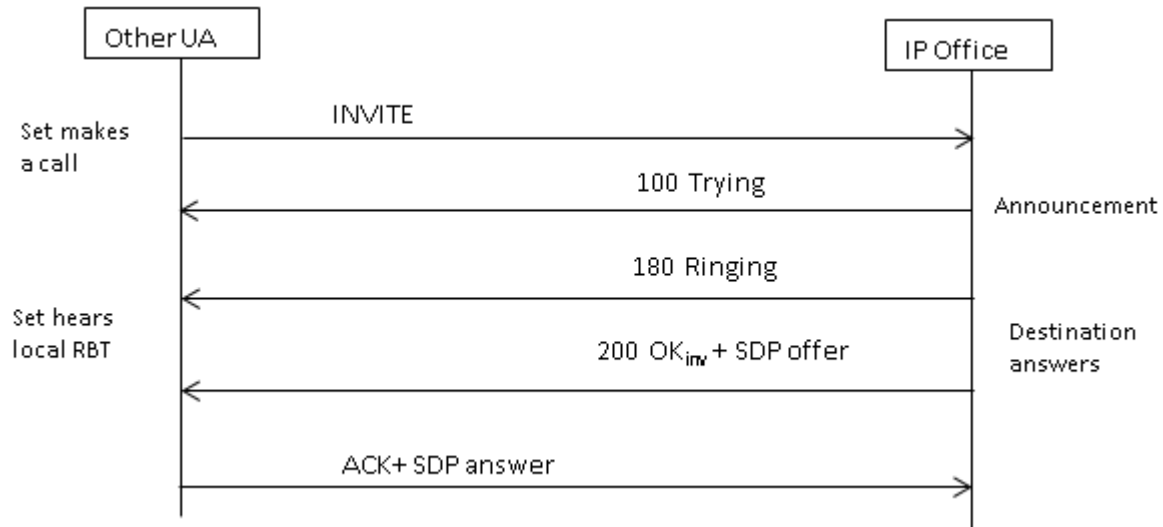

**INVITE without SDP, call terminates on H.323 endpoint**

If the destination of the call is an H.323 trunk, the destination media address is not known when the call is answered. Therefore, the SDP offer in 200 OK will contain a null port number (and IP address). Once the logical channels are opened on the H.323 side, IP Office sends a re-INVITE using the real media address.



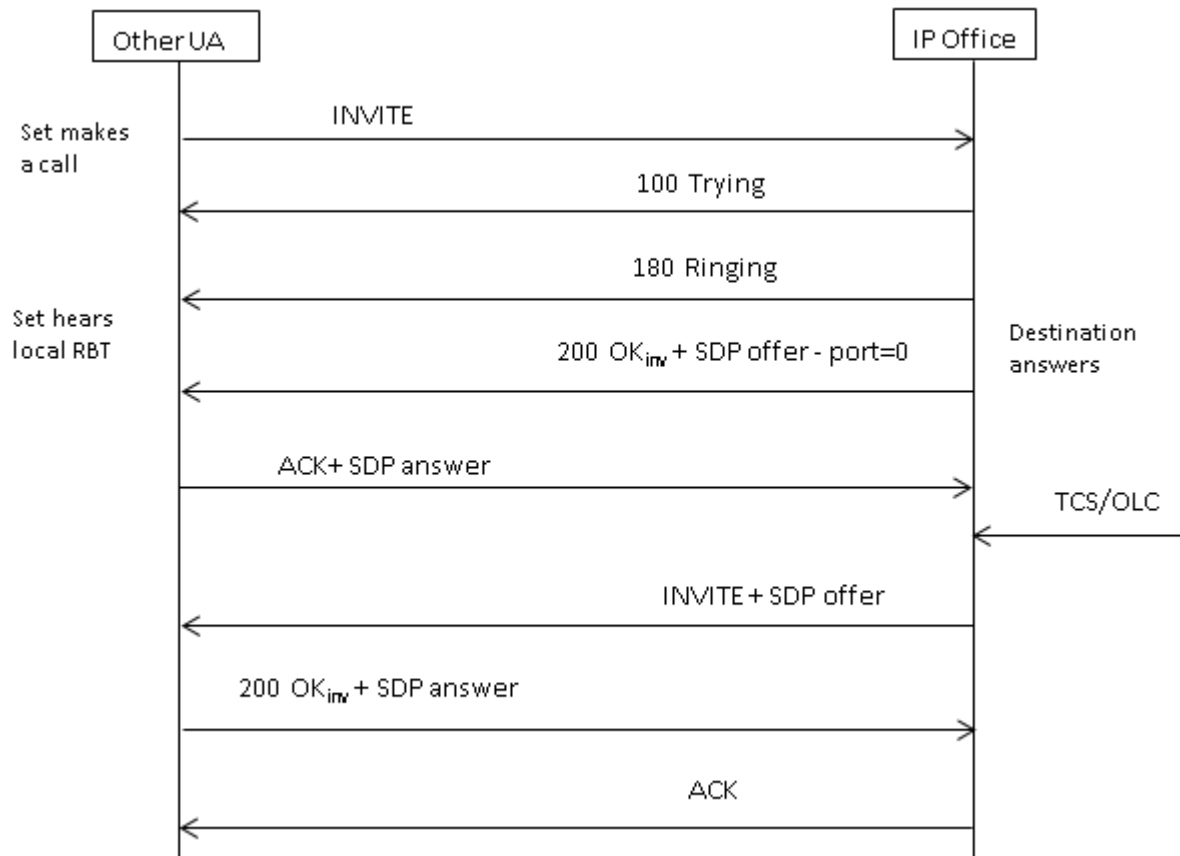

### Related links

[Incoming call message details](#) on page 772

## Codec selection

Codec selection is based on the Offer/Answer model specified in RFC 3264. The endpoint that issues the offer includes the list of codecs that it supports. IP Office offers the codecs set on the **SIP line | VoIP** tab, not those that are set on the extension.

The other endpoint sends an answer that should normally contain a single codec. If there are multiple codecs in the answer, IP Office only considers the first codec. If the SIP Line is configured to do Codec Lockdown (Re-Invite Supported is a prerequisite) then it will send another INVITE with the single chosen codec.

### Related links

[SIP messaging](#) on page 767

## DTMF transmission

DTMF over RTP (RFC 2833) can be used in IP Office. Asymmetric dynamic payload negotiation is supported when it is necessary to bridge multiple SIP endpoints that do not support payload negotiation. The value used for an initial offer is configured on the **System | Codecs** tab. The default value is 101. Upon receipt of an offer with an RFC2833 payload type, IP Office will automatically use the proposed value rather than its own configured value. This helps to support networks that do not negotiate payload types.

There are cases in which direct media is desirable between SIP trunks and endpoints that do not support RFC2833. To allow for this, if key presses are indicated from the extension, the IP Office will 'shuffle' the media in. This connects its own media engine to the endpoint and to the SIP trunk, and injects the digits in-band using the negotiated dynamic payload. After fifteen seconds of no key presses, the media will be shuffled back out to re-establish a direct connection again.

### Related links

[SIP messaging](#) on page 767

---

## Fax over SIP

T.38 Fax over SIP is supported on the IP500 V2 platform deployed as standalone or as an expansion gateway. G.711 fax is also supported, and is supported on Linux servers. For networks that do or do not support T.38, IP Office allows both G3 and Super G3 fax machines to interoperate.

There are configuration parameters that control the behavior in different networks. If T.38 is supported in a network, then it may make sense to select T.38 as the Fax Transport preference in order to make use of the inherent quality provided by the redundancy mechanisms. On the other hand, if all of the fax machines in the network are Super G3 capable, there may be a need to take advantage of the increased speed that this encoding provides. Since T.38 is not capable of encoding Super G3, G.711 may be a better choice for the Fax Transport. In either case, IP Office will accept codec change requests from the far SIP endpoint to switch to T.38 or to G.711.

T.38 Fax Transport and Direct Media are mutually exclusive on a given SIP Line. IP Office keeps itself in the media path so that it can detect fax tones to make the switch to T.38.

### Related links

[SIP messaging](#) on page 767

---

## Hold scenarios

### Hold originated by IP Office

When an IP Office DS extension or non-IP trunk puts a SIP trunk on hold, there is no indication to the network. The voice path is merely switched in the TDM domain to the appropriate hold

treatment source, be it tones, silence or music. For IP extensions and trunks, be they H.323 or SIP, if the call uses direct media, there will be a re-INVITE sent to redirect the media source from the extension or trunk endpoint to a port on the IP Office in order to connect hold treatment. When the call is then unheld, another INVITE will go out to connect the extension with the far end.

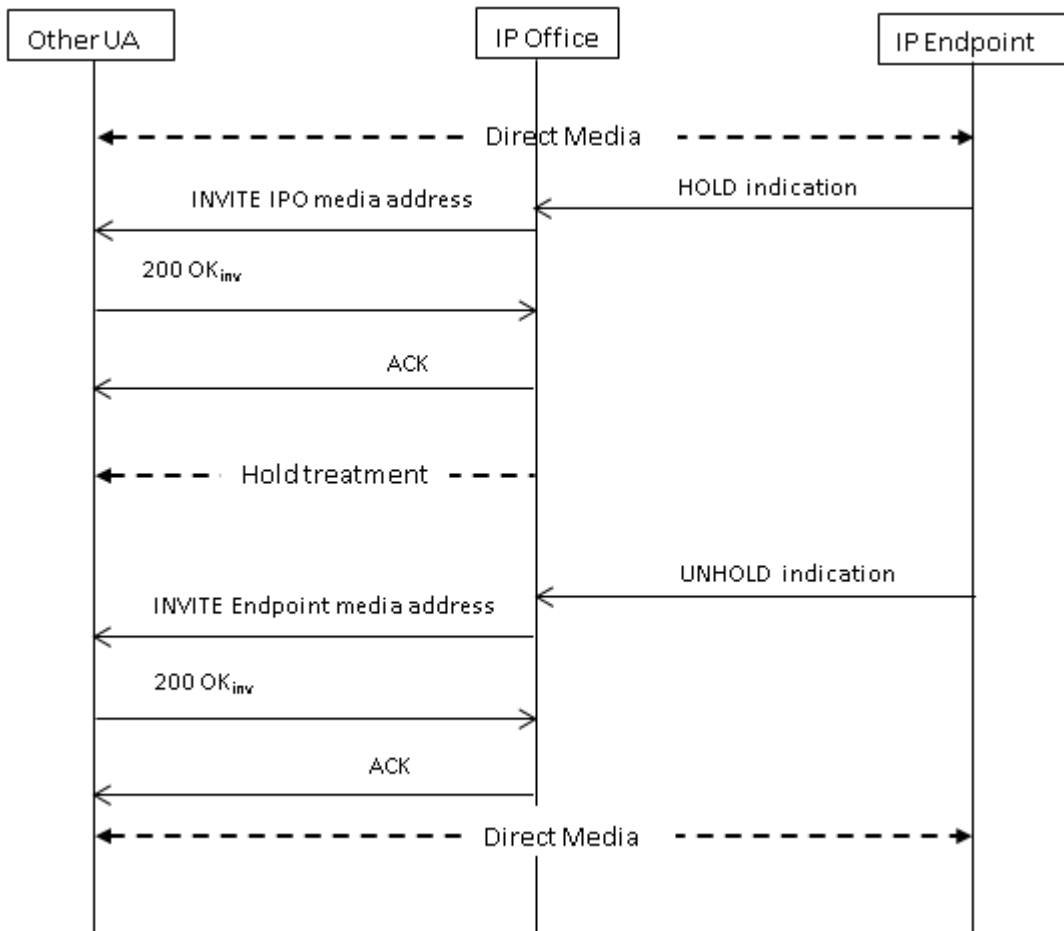

### Hold originated by far end

The far end of a SIP trunk can put the IP Office on hold by sending it re-INVITE with an SDP Offer containing:

- A **sendonly** attribute. IP Office replies with an SDP Answer containing the **recvonly** attribute.
- An **inactive** attribute. IP Office replies with **inactive**.
- A zero media connection address (c=0.0.0.0). IP Office replies with **inactive**.

### Unhold

A held call is unheld by means of an SDP Offer with the **sendrecv** attribute (or no direction attribute, since **sendrecv** is assumed if not specified).

### Unhold from mutual hold

Either end can un-hold the other end, i.e., allow it to transmit again, by sending a new Offer with the **sendrecv** or **recvonly** attribute. The other end replies with **sendonly** if the call is still on hold at its end.

#### Related links

[SIP messaging](#) on page 767

---

## SIP REFER

After a SIP call has been established between two parties (the “Primary” call), the SIP REFER method is used by the **TransferOR** end of the call to transfer the **TransferEE** end to a **Transfer Target**. The REFER message provides the Transfer Target’s contact information in the Refer-To header. This causes the TransferEE to establish the Secondary call to the Transfer Target, thus completing the transfer.

For public SIP trunks, IP Office supports only consultative call transfer using REFER. Consultative transfer is also known as Attended. With consultative transfer, the TransferOR puts the Primary call on hold and establishes a **Consult** call to another party. After the consultation, the TransferOR completes the transfer, causing the TransferEE to connect to the Transfer Target, thereby replacing the Transfer Target’s call with the TransferOR.

REFER can be configured to accept incoming, reject incoming, or decide based on the presence of REFER in the **Allow:** header in responses to OPTIONS messages. Similarly, there is the same configuration for outgoing REFER.

Although the TransferOR and TransferEE must be SIP endpoints, the Transfer Target may be a TDM, PRI, H.323 or SIP terminal on the same IP Office, or an endpoint reachable over the same SIP line as the REFER request is received from.

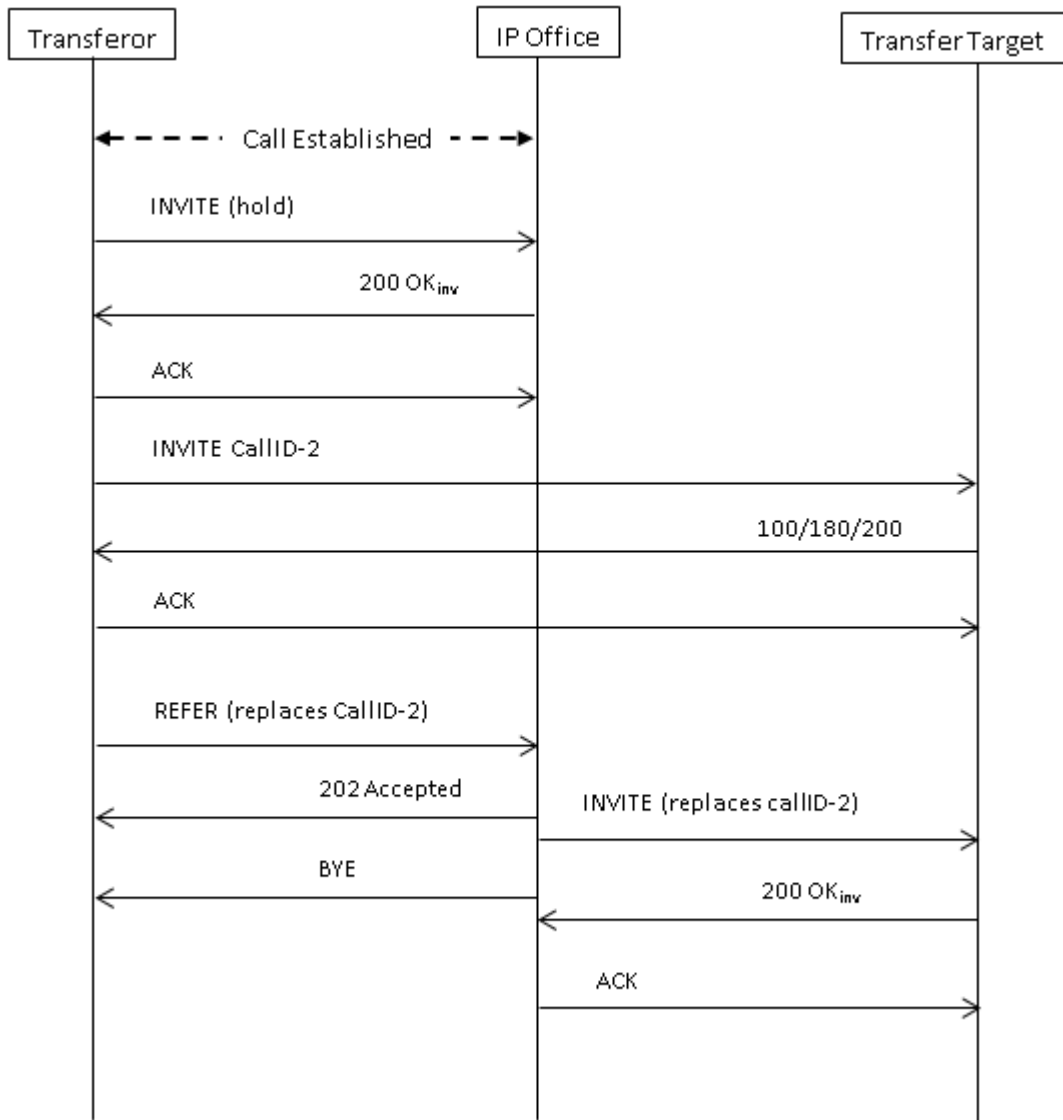
**Related links**

[SIP messaging](#) on page 767

---

## IP Office SIP trunk specifications

This section outlines the SIP trunk capabilities supported by IP Office.

**Related links**

[Configuring SIP Trunks](#) on page 761

[RFCs](#) on page 783

[Transport protocols](#) on page 784

[Request methods](#) on page 784

[Response methods](#) on page 784

[Headers](#) on page 785

## RFCs

- ITU-T T.38 Annex D, Procedures for real-time Group 3 facsimile communication over IP networks
- RFC 1889 - RTP: A Transport Protocol for Real-Time Applications
- RFC 2327 - SDP: Session Description Protocol
- RFC 2617 - HTTP Authentication: Basic and Digest Access Authentication
- RFC 2833/RFC 4733 - RTP Payload for DTMF Digits, Telephony Tones and Telephony Signals
- RFC 2976 - The SIP INFO Method
- RFC 3087 - Control of Service Context using SIP Request-URI
- RFC 3261 - Session Initiation Protocol
- RFC 3262 - Reliability of Provisional Responses in the Session Initiation Protocol (SIP)
- RFC 3263 - Session Initiation Protocol (SIP): Locating SIP Servers
- RFC 3264 - An Offer/Answer Model with the Session Description Protocol (SDP)
- RFC 3311 - The Session Initiation Protocol (SIP) UPDATE Method
- RFC 3323 - A Privacy Mechanism for the Session Initiation Protocol (SIP)
- RFC 3325 - Private Extensions to the Session Initiation Protocol (SIP) for Asserted Identity within Trusted
- RFC 3326 - The Reason Header Field for the Session Initiation Protocol (SIP)
- RFC 3398 - Integrated Services Digital Network (ISDN) User Part (ISUP) to Session Initiation Protocol (SIP) Mapping
- RFC 3407 - Session Description Protocol (SDP) Simple Capability
- RFC 3489 - STUN - Simple Traversal of User Datagram Protocol (UDP) Through Network Address Translators (NATs)
- RFC 3515 – The Session Initiation Protocol (SIP) Refer method
- RFC 3550 - RTP: A Transport Protocol for Real-Time Applications
- RFC 3551 - RTP Profile for Audio and Video Conferences with Minimal Control
- RFC 3665 - Session Initiation Protocol Basic Call Flow Examples
- RFC 3666 - Session Initiation Protocol PSTN Call Flows
- RFC 3725 - Best Current Practices for Third Party Call Control (3pcc) in the Session Initiation Protocol (SIP)
- RFC 3824 - Using E.164 numbers with the Session Initiation Protocol (SIP)
- RFC 3842 - A Message Summary and Message Waiting Indication Event Package for the Session Initiation Protocol
- RFC 3891 - The Session Initiation Protocol (SIP) "Replaces" Header
- RFC 3960 - Early Media and Ringing Tone Generation in the Session Initiation Protocol (SIP)
- RFC 4028 - Session Timers in the Session Initiation Protocol (SIP)
- RFC 4566 - SDP: Session Description Protocol
- RFC 5359 - Session Initiation Protocol Service Examples
- RFC 5379 - Guidelines for Using the Privacy Mechanism for SIP
- RFC 5806 - Diversion Indication in SIP
- RFC 5876 - Updates to Asserted Identity in the Session Initiation Protocol (SIP)
- RFC 6337 - Session Initiation Protocol (SIP) Usage of the Offer/Answer Model
- RFC 6432 - Carrying Q.850 Codes in Reason Header Fields in SIP (Session Initiation Protocol) Responses

**Related links**

[IP Office SIP trunk specifications](#) on page 781

---

## Transport protocols

- UDP
- TCP
- RTP
- RTCP

**Related links**

[IP Office SIP trunk specifications](#) on page 781

---

## Request methods

- |             |           |
|-------------|-----------|
| • INVITE    | • NOTIFY  |
| • ACK       | • PRACK   |
| • BYE       | • OPTIONS |
| • CANCEL    | • UPDATE  |
| • INFO      | • PUBLISH |
| • REFER     | • MESSAGE |
| • REGISTER  | • PING    |
| • SUBSCRIBE |           |

**Related links**

[IP Office SIP trunk specifications](#) on page 781

---

## Response methods

- |                               |                |
|-------------------------------|----------------|
| • 100 Trying                  | • 202 ACCEPTED |
| • 180 Ringing                 | • 3XX          |
| • 181 Call Is Being Forwarded | • 4XX          |
| • 182 Call Queued             | • 5XX          |
| • 183 Session progress        | • 6XX          |
| • 200 OK                      |                |

**Related links**

[IP Office SIP trunk specifications](#) on page 781



---

## Headers

- Accept
- Alert-Info
- Allow
- Allow-Event
- Authorization
- Call-ID
- Contact
- Content-Length
- Content-Type
- CSeq
- Diversion
- From
- History-Info
- Max-Forwards
- P-Asserted-Identity
- P-Early-Media
- P-Preferred-Identity
- Privacy
- Proxy-Authenticate
- Proxy-Authorization
- Proxy-Require
- Require
- Remote-Party-ID
- Server
- Session-Timers
- Supported
- To
- User-Agent
- Via
- WWW-Authenticate

### Related links

[IP Office SIP trunk specifications](#) on page 781

# Chapter 16: Configuring Small Community Networking

Systems linked by IP Office Line IP trunks can enable voice networking across those trunks to form a multi-site network. Within a multi-site network, the separate systems automatically learn each other's extension numbers and user names. This allows calls between systems and support for a range of internal call features, see Supported Small Community Network Features.

## Capacity

The following are the supported capacity limits for a Small Community Network system.

<b>Maximum Number of Systems</b>	32
<b>Maximum Number of Users</b>	1000
<b>Maximum H.323 Line Hops Between Systems</b>	5
<b>Star H.323 Line Layout</b>	✓
<b>Serial H.323 Line Layout</b>	✓
<b>Mesh H.323 Line Layout</b>	✓

## Configuration Summary

To set up a Small Community Network, the following are required:

A working IP Office Line trunk between the systems, that has been tested for correct voice and data traffic routing.

- The arrangement the IP Office Line trunks must meet the requirements detailed in Supported Small Community Network Layouts.
- Within a particular system, all SCN trunks should be on the same LAN interface.
- VCM channels are required in all systems.
- The extension, user and group numbering on each system must be unique.
- The user and group names on each system must be unique.
- We also recommend that all names and numbers (line, services, etc) on the separate systems are kept unique. This will reduce potential maintenance confusion.
- The **Outgoing Group ID** on the Small Community Network lines should be changed to a number other than the default **0**.
- All systems should use the same set of telephony timers, especially the **Default No Answer Time**.

- Check that all systems in the network are configured to use the same Codecs.
- Only one system should have its **Voicemail Type** set to **Voicemail Pro/Lite**. All other systems must be set to either **Centralized Voicemail** or **Distributed Voicemail**. No other settings are supported.

### Software Level Interoperation

Small Community Networks is supported between systems with the same major software level or one level of difference in major software level. For example between 9.1 and 9.0 (same major level) and between 8.0 and 9.0 (one major level of difference).

This option is intended mainly to allow the phased upgrading of sites within a Small Community Network. It is still recommended that all systems within a network are upgraded to the same level where possible. Within a Small Community Network including differing levels of software, the network features and capacity will be based on the lowest level of software within the network.

### Related links

[Supported Small Community Network Network Layouts](#) on page 787

[Telephone Features Supported Across Server Edition and SCN Networks](#) on page 110

[Voicemail Support](#) on page 789

[Enabling Small Community Networking](#) on page 790

[Small Community Network Management](#) on page 792

[Small Community Network Remote Hotdesking](#) on page 801

[Small Community Network Fallback](#) on page 802

[SCN Short Code Programming](#) on page 803

---

## Supported Small Community Network Network Layouts

The allowed arrangement of IP Office Lines between the systems depends on the lowest software level of any system in the network. Note that we are referring to IP Office Lines configured in the system configurations. The actual IP network configuration, including IP routes in the system configurations, can differ as per the customer network requirements.

**Star/Serial Layouts** The following are examples of star and serial layouts.

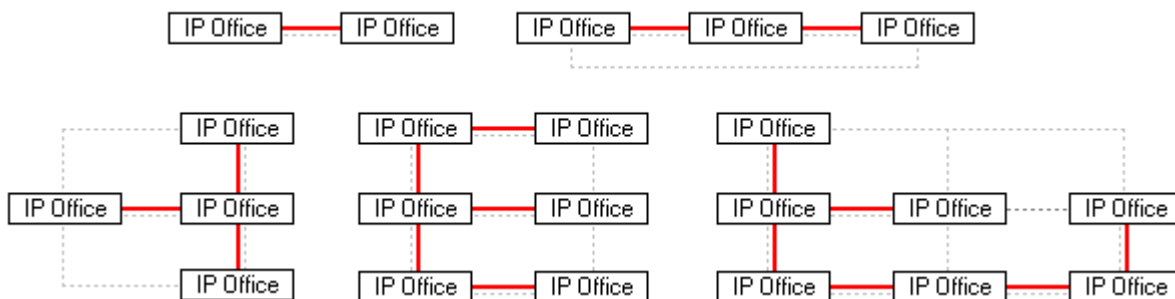

---- = IP network, | = IP Office Line.

**Mesh Layout** A mesh layout is one where there is more than one possible IP Office Line route between any two systems. The following are examples of mesh layouts. Mesh, star and serial layouts can be combined.

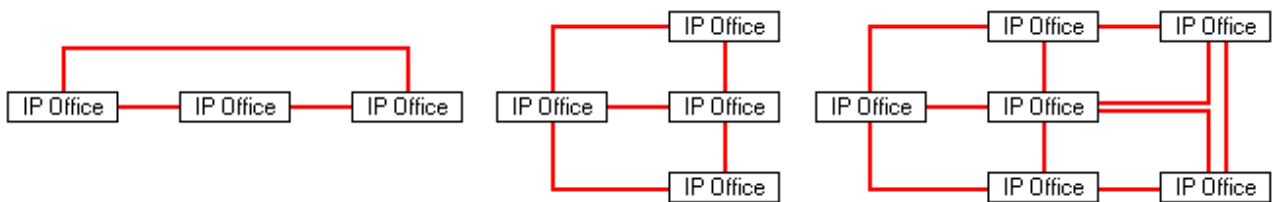

**Small Community Network Signalling** Small Community Network uses a signalling similar to RIP in order to update each other of their presence. This traffic can be seen in the System Monitor application as AVRIP packets. This traffic is sent to port 50795 on which each system listens.

Each system in the Small Community Network transmits an update every 30 seconds. Additionally BLF updates are transmitted when applicable up to a maximum of every 0.5 seconds. Typically the volume is less than 1Kbps per system.

#### Related links

[Configuring Small Community Networking](#) on page 786

## Telephone Features Supported Across Server Edition and SCN Networks

Each system running IP Office in a multi-site network acts as a self-contained IP Office telephone system. In addition to the remote systems sharing knowledge of user and hunt group extension numbers, the following additional telephony features are supported between systems in a multi-site network. Features not listed are not supported across the multi-site network.

- **Absence Text**
- **Advertised Hunt Groups** Hunt groups set to advertised can be dialed by users on other systems
- **Anti-tromboning** Calls routed across the multi-site network and back to the originating system are turned back into internal calls on the originating system only.
- **Break Out Dialing**
- **Call Park / Unpark Call**
- **Call Pick-up Extension**
- **Call Tagging**
- **Callback When Free**
- **Centralized Call Log**

- **Centralized Personal Directory**
- **Conference**
- **Distributed Hunt Groups**
- **Distributed Voicemail Server Support** When using Voicemail Pro, each system can support its own Voicemail Pro server.
- **Enable ARS / Disable ARS**
- **Extension Dialing** Each system automatically learns the user extension numbers available on other systems and routes calls to those numbers.
- **Resiliency Options**
- **Fax Relay**
- **Follow Me Here / Follow Me To**
- **Forwarding**
- **Hold** Held calls are signalled across the network.
- **Internal Twining**
- **Intrusion Features**
- **Mobile Call Control** Licensed mobile call control users who remote hot desk to another system take their licensed status with them.
- **Music On Hold Source Selection**
- **Remote Hot Desking**
- **Set Hunt Group Out of Service / Clear Hunt Group Out of Service**
- **Transfer** Calls can be transferred to network extensions.
- **User DSS/BLF** Monitoring of user status only. The ability to use additional features such as call pickup via a USER button will differ depending on whether the monitored user is local or remote. Indication of new voicemail messages provided by SoftConsole user speed dial icon is not supported.
- **User Profile Resilience** When a user hot desks to another system, they retain their Profile settings and rights.

#### Related links

[Working with the Server Edition Manager User Interface](#) on page 105

[Configuring Small Community Networking](#) on page 786

---

## Voicemail Support

Within a Small Community Network, a single Voicemail Pro can be used to provide voicemail services for all the systems. For full details of installation and setup refer to the Voicemail Pro documentation. The Voicemail Pro is licensed and hosted by a chosen central system and

provides full operation for that system. The voicemail features supported for the other remote systems are listed below:

The use of additional Voicemail Pro servers is supported. The distributed servers provide call recording and auto attendant functions to their local system. The central Voice Pro server is still used as the message store for all messages. Refer to the Voicemail Pro documentation.

- **User mailboxes.**
- **Call recording.** Recording of incoming call routes is only supported for destinations on the same system, not for remote Small Community Network destinations.
- **Dial by Name.**
- **Auto Attendants.**
- **Breakout** Requires that the numbers used are routable by the system hosting the voicemail server.
- **Announcements**
- **UMS Web Services** Users for UMS Web Services (IMAP and or web voicemail) are licensed through the **UMS Web Services** license on their host system. This applies even if the user remote hot desks to another system in the Small Community Network.

#### Related links

[Configuring Small Community Networking](#) on page 786

---

## Enabling Small Community Networking

The process below adds an IP Office Line to the system configuration. It is assumed that data routing between the systems has already been configured and tested. Adding Small Community Network connections between systems can also be done using Manager's Small Community Network Management mode.

#### Related links

[Configuring Small Community Networking](#) on page 786

---

## Setup the VoIP Line from System A to System B

### About this task

Receive the system configuration for System A. Prepare the system for addition to the Small Community Network:

## Procedure

1. Change all extensions numbers and names to values that will be unique within the multi-site network.
  - For users and extensions this can be done using the **Extension Renumber** tool. That will adjust all users and extension and all items using those numbers, for example hunt group memberships and incoming call routes.
  - For hunt groups, each hunt group must be change individually.
2. Click **Line** to display a list of existing lines.
3. Right-click on the displayed list and select **New** and then **IP Office Line**.
4. Select the **Line** tab and set the following:
  - In the **Transport Type** field, select **Proprietary**.
  - In the **Networking Level** field, select **SCN**.
  - In the **Description** field, enter a description of the link. For example **System B Small Community Network**.
  - Set the **Outgoing Group ID** to a unique value. For example match the automatically assigned **Line Number** value.
5. Under **Gateway**, set the following:
  - For the **Gateway IP Address**, enter the IP address of the remote System B.
  - Use of **IP Office SCN - Fallback** is detailed in Small Community Network Fallback.
6. Click the **VoIP Settings** tab.
  - 
  - Select the preferred **Compression Mode**. The same mode must be used by all VoIP lines and extensions within the network.
  - The other option can be configured as required but must be matched by the other IP Office Lines in the network. For example the Silence Suppression settings on all the network trunks must match.
7. Select **System | Voicemail**.
  - a. Only one system should have its **Voicemail Type** set to **Voicemail Pro/Lite**.  
The **Voicemail IP Address** will be the IP address of the central voicemail server PC.
  - b. Any other system with its own Voicemail Pro server PC should have its **Voicemail Type** set to **Distributed Voicemail**.  
The **Voicemail IP Address** should be the IP address of the distributed voicemail server PC. The **Voicemail Destination** should be set to the **Outgoing Group ID** used for the Small Community Network line to the system that is set as **Voicemail Pro/Lite**.
  - c. All other systems should have their Voicemail Type set to Centralized Voicemail.

The **Voicemail Destination** should be set to the **Outgoing Group ID** used for the Small Community Network line to the system that is set as **Voicemail Pro/Lite**.

8. Save the configuration and reboot System A.

### Next steps

Set up the IP Office Line from B to A.

---

## Setup the VoIP Line from System B to System A

### Procedure

1. On the remote system, repeat the previous steps to create an IP Office Line to System A. As stated above, where possible the line settings, especially the VoIP settings, must match those used for other IP Office Lines in the network.
2. Load the configuration and reboot the remote system.

### Next steps

Test by making calls between extensions on the different systems

---

## Small Community Network Management

Manager supports the ability to load and manage the configurations of the systems in a Small Community Network at the same time. Manager must be enabled for Small Community Network discovery.

When the configurations of the systems in a Small Community Network are loaded, Manager switched to Small Community Network management mode. This differs from normal system configuration mode in a number of ways:

- A network viewer is available. In addition to giving a graphical view of the Small Community Network, the view can be used to add and remove links between the systems in the Small Community Network.
- In the configuration tree, the records for users and hunt groups on all systems are grouped together.
- Time Profiles and User Right common to all systems are grouped together.
- The configuration settings for each system in the Small Community Network can be accessed and edited.

### Related links

[Configuring Small Community Networking](#) on page 786

[Enabling SCN Discovery](#) on page 793

[Creating a Common Admin Account](#) on page 793

[Loading a Small Community Network Configuration](#) on page 794



[Editing a Small Community Network Configuration](#) on page 795

[Using the Network Viewer](#) on page 796

[System Inventory](#) on page 801

---

## Enabling SCN Discovery

### About this task

In order for the **Select IP Office** menu to groups systems in a Small Community Network and allow loading of all the Small Community Network configurations, Manager must be enabled for SCN discovery.

### Procedure

1. Select **File | Preferences**.
2. Select the **Discovery** tab.
3. Select the SCN Discovery option.
4. Check that the other discovery setting are sufficient to discover all the systems in the Small Community Network.
5. Click **OK**.

### Related links

[Small Community Network Management](#) on page 792

---

## Creating a Common Admin Account

### About this task

When managing multiple systems, it may be useful to create a common user name and password on all the systems for configuration access. This tool can be used to create a new service user account, **SCN\_Admin**, for configuration access.

This process requires you to have a user name and password for security configuration access to each of the systems.

Select **Tools | SCN Service User Management**.

The option is not shown if a Basic Mode system configuration is loaded. If no configuration is loaded, and the option is not shown, select **View | Advanced View**.

### Procedure

1. The **Select IP Office** menu displays the list of discovered systems.
2. Select the systems for which you want to create a common configuration account.  
Click **OK**.
3. A user name and password for security configuration access to each system is requested.

Enter the values and click **OK**. If the same values can be used for all systems enter those values, select **Use above credentials for all remaining, selected IPOs**. If each system requires a different security user names and password, deselect **Use above credentials for all remaining, selected IPOs**.

4. The systems will be listed and whether they already have an **SCN\_Admin** account is shown.
5. To create the **SCN\_Admin** account on each system and set the password for those account click on **Create Service User**.
6. Enter the common password and click **OK**.
7. The password can be changed in future using the Change Password option.
8. Click **Close**.

#### Related links

[Small Community Network Management](#) on page 792

---

## Loading a Small Community Network Configuration

### About this task

If Manager is configured with SCN Discovery enabled, the **Select IP Office** menu will display any SCNs it discovers.

### Procedure

1. With no configuration loaded, click on  or select **File | Open Configuration**.
2. The **Select IP Office** menu is displayed.  
Any systems in a Small Community Network will be grouped together.
3. To load the configuration of all the systems in the network, click the check box next to the network name and then click **OK**.

If a  warning icon is displayed next to the **SCN** check box, it indicates that not all the systems known to be in the Small Community Network were discovered. Hovering the cursor over the icon will display details of the missing systems. Loading the network configuration at this time would not include the configuration of the missing system or systems. The missing systems:

- May be disconnected
- The discovery settings for the Manager PC may be incorrect.
- The data routing between the Manager PC and the missing systems may be incorrect or blocked.

4. Enter the name and password for configuration access to each system.

If the systems all have a common user name and password (see Common Administrator Access below), select **Use above credentials for all remaining selected IPOs**. Click **OK**.

5. Manager will load and display the combined configurations in Small Community Network Management mode.

### Related links

[Small Community Network Management](#) on page 792

---



## Editing a Small Community Network Configuration

When the configuration of a Small Community Network is loaded, Manager displays the configuration in a different way from when the configuration of a single system is loaded. The main differences are in how configuration records are grouped in the configuration tree.



Clicking on the  Small Community Network icon displays the Network Viewer which shows the lines between the systems in the Small Community Network.

**Small Community Network Configuration Records** Certain records from each of the systems in the Small Community Network are grouped together in the configuration tree differently from when just a single system configuration is loaded. There are two types, unique Small Community Network records and shared Small Community Network records:

**Unique Records** They can be edited here and the system to which they belong is indicated in the group pane and in the title bar of the details pane. However, to add or delete these types of record must be done within the configuration records of the particular system that will host the entry's configuration details.

- All user in the Small Community Network are shown under the  **User** icon.
- All hunt groups in the Small Community Network are shown under the  **Hunt Group** icon.

**Shared Records** Shared records are configuration items that exist on all systems in the Small Community Network, having the same name and settings on each system. Editing the shared record updates the matching copy in the configuration of each system. Similarly, adding or deleting a shared record adds or deletes from the individual system configurations. If the copy of the shared record within an individual configuration is edited, it is no longer a shared record for the Small Community Network though the individual records on other system will remain. Changing the individual records back to matching will turn the records back into a shared record.

- Shared time profiles are shown under the  **Time Profile** icon.
- Shared user rights are shown under the  **User Rights** icon.

**Individual System Configurations**  The full configuration for each system in the Small Community Network can be accessed and edited as required. It is possible to copy and paste configuration records between systems using the configuration tree.

Saving Changes

When the  save icon or **File | Save Configuration** is selected, the menu for multiple configuration saves is displayed. It provides similar options for a normal single configuration save. Note that when working in Small Community Network Management mode, after saving configuration changes the Manager will always close the displayed configuration.

**Change Mode** If Manager thinks the changes made to the configuration settings are mergeable, it will select **Merge** by default, otherwise it will select **Reboot**.

- **Merge** Send the configuration settings without rebooting the system. This mode should only be used with settings that are mergeable. Refer to Mergeable Settings.
- **Reboot** Send the configuration and then immediately reboot the system.
- **Reboot When Free** Send the configuration and reboot the system when there are no calls in progress. This mode can be combined with the **Call Barring** options.
- **Timed** The same as When Free but waits for a specific time after which it then wait for there to be no calls in progress. The time is specified by the **Reboot Time**. This mode can be combined with the **Call Barring** options.

**Reboot Time** This setting is used when the reboot mode **Timed** is selected. It sets the time for the system reboot. If the time is after midnight, the system's normal daily backup is canceled.

**Call Barring** These settings can be used when the reboot mode **Reboot When Free** is selected. They bar the sending or receiving of any new calls.

**Error Status** The warning will appear if the configuration being sent contains any validation errors indicated by a  icon in the error pane. The configuration can still be sent if required.

#### Related links

[Small Community Network Management](#) on page 792

---

## Using the Network Viewer

Clicking on Small Community Network in the configuration tree displays the Network Viewer. This shows each of the systems in the Small Community Network and the links between each of the systems. Systems with attached Voicemail Pro servers are also indicated.

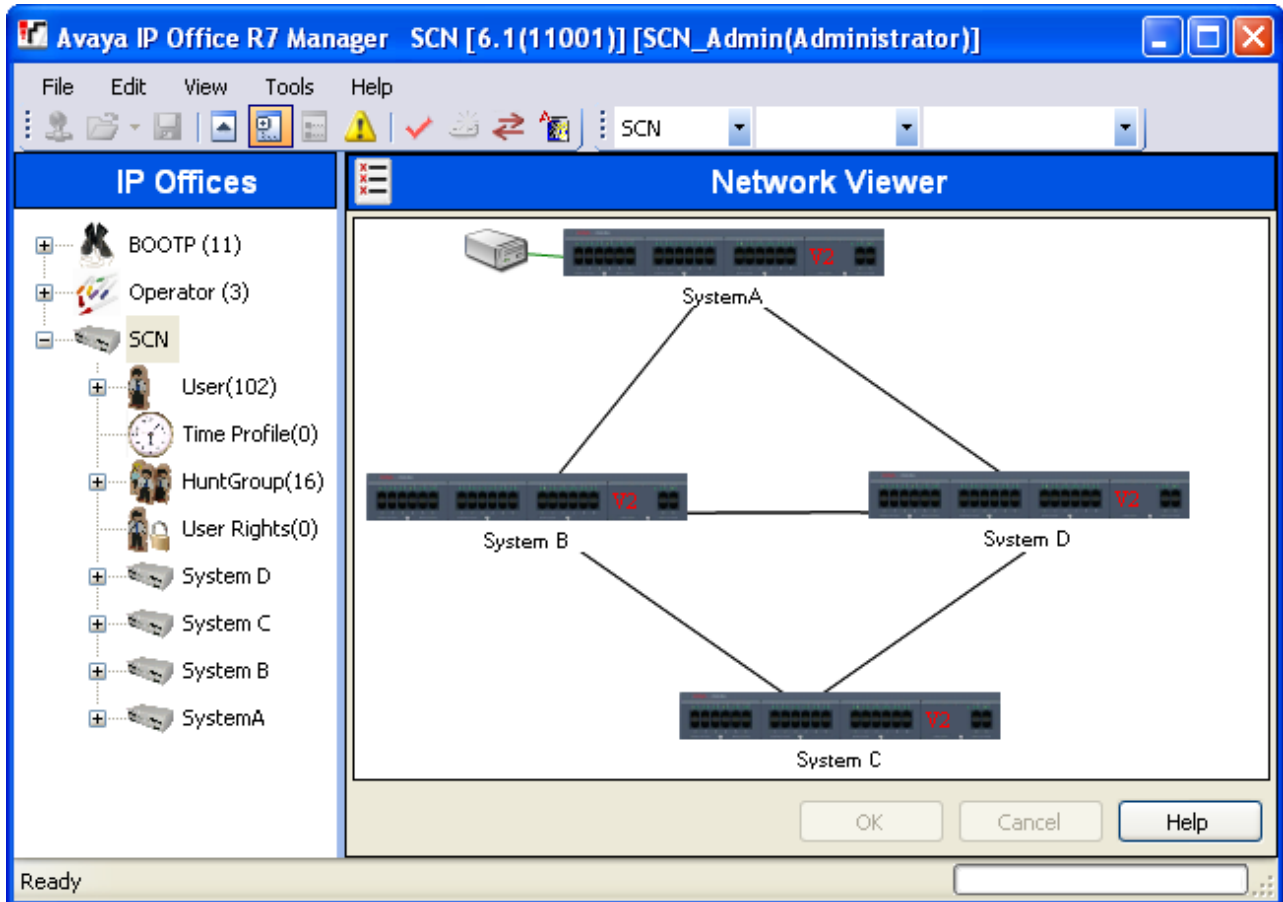

**Green** System with Voicemail Pro system.

**Black** Small Community Network line between two systems.

**Red** Incorrect Small Community Network line between systems (probably one-way connection). Right-click on the line and select **Repair**.

You can use the Network Viewer to perform a range of functions:

- Arrange the View
- Launch System Status
- Launch Voicemail Pro
- Add an IP Office Line
- Add a system
- Remove an IP Office Line
- Remove a system from the Small Community Network
- Repairing an IP Office Line
- Add a Background Image

## Related links

[Small Community Network Management](#) on page 792

## Arranging the View

### About this task

#### Procedure

You can click and drag items around in order to position them where required.

Alternatively if you right click on the view you can select Auto Arrange.

#### \* Note:

The position of elements in the network view are stored as part of the system configuration. Therefore changes to the view will require the configuration to be saved.

## Adding a Line Within the Small Community Network

### About this task

You can use the network viewer to add a Small Community Network link between two systems in the Small Community Network that are currently linked. This process will add new H.323 Small Community Network line records to the configurations of each of the systems.

#### \* Note:

Adding a line between systems will require those systems to reboot when the changes are saved.

#### Procedure

1. Right click on the starting system for the link.

Select **Connect To** and select the name of the other system in the Small Community Network to which you want to link.

2. Select the type of line, **IP Office SCN** or **IP Office SCN-Fallback**.
3. Click **OK**.

If Small Community Network-Fallback is selected, the actual backup function still need to be configured.

- a. The newly added line is displayed in the network viewer.
- b. Click **OK**.

## Repairing a Line Within the Small Community Network

### About this task

A red line in the network viewer indicates a incorrectly configured line between two systems in the Small Community Network. Typically this will be a line configured in one of the systems but not matched by a line configured in the other system. The network viewer can be used to correct this error.

## Procedure

1. Note that adding a line between systems will require those systems to reboot when the changes are saved.
2. Right click on the red line and select **Repair Line**.
3. The line is changed to black.
4. Click **OK**.

## Adding a System to the Small Community Network

### About this task

You can use the network viewer to add a Small Community Network line to a system not yet in the Small Community Network. This process will add new H.323 Small Community Network line records to the configurations of each of the systems.

### Procedure

1. Note that adding a line between systems will require those systems to reboot when the changes are saved.
2. Right click on the starting system for the link.  
Select **Connect To** and select **Discovery**.
3. The **Select IP Office** menu will display any discoverable systems not already in the Small Community Network.

If the discovery includes systems already in another Small Community Network it will not indicate such. If you want to add such a system in order to join the SCNs you can do so. However after adding the system, you should immediately save the configuration and reload the Small Community Network.

- a. Select the required system and click **OK**.
- b. Enter the name and password for configuration access to the selected system and click **OK**.
- c. The newly added system is displayed in the network viewer.
- d. Click **OK**.

The configuration of the newly added system is now included in the configuration tree.

- e. If the **Error List** is visible (**View | Error Pane**), check that none of the error are Small Community Network specific errors, for example duplicate names or extension numbers.

## Removing a Small Community Network Line

### About this task

You can use the network viewer to remove the Small Community Network lines between two systems in the Small Community Network.

### Procedure

1. Note that removing a link between systems will require those systems to reboot when the changes are saved.
2. Right click on the link and select **Delete Line**.
3. The line is removed from the network viewer.
4. Click **OK**.

## Removing a System

### About this task

You can use the network viewer to remove a system from the Small Community Network.

### Procedure

1. Note that removing a system will require previous linked systems to reboot when the changes are saved.
2. Right click on the system and select **Remove From Small Community Network**.
3. Any lines to other system in the Small Community Network are removed.
4. Click **OK**.

## Start System Status

### About this task

If the System Status Application is also installed on the Manager PC, you can start it for a particular system.

### Procedure

1. Right click on the system and select **System Status**.
2. The application is started and the login form pre filled with the IP address of the system.

## Start Voicemail Pro

### About this task

If the Voicemail Pro client is also installed on the Manager PC, you can start it for the any system with an associated Voicemail Pro server.

### Procedure

Right click on the voicemail server icon and select **Launch VMPro Client**.

## Add a Background Image

### About this task

You can select an image file to be displayed in the background of the Network Viewer display. This file is not saved as part of the configuration in any way, ie. if the image file is moved or deleted it is not longer used by Manager.



## Procedure

1. Right click on the general background area of the network viewer and select **Background Image**.
2. Select **Set Background Image** to browse to the location of the file to be used.
3. The Visible option can be used to switch the display of the background image on or off.

## System Inventory

When working in Small Community Network Management mode, clicking on the **System** icon for a particular system displays a system inventory page for that system.

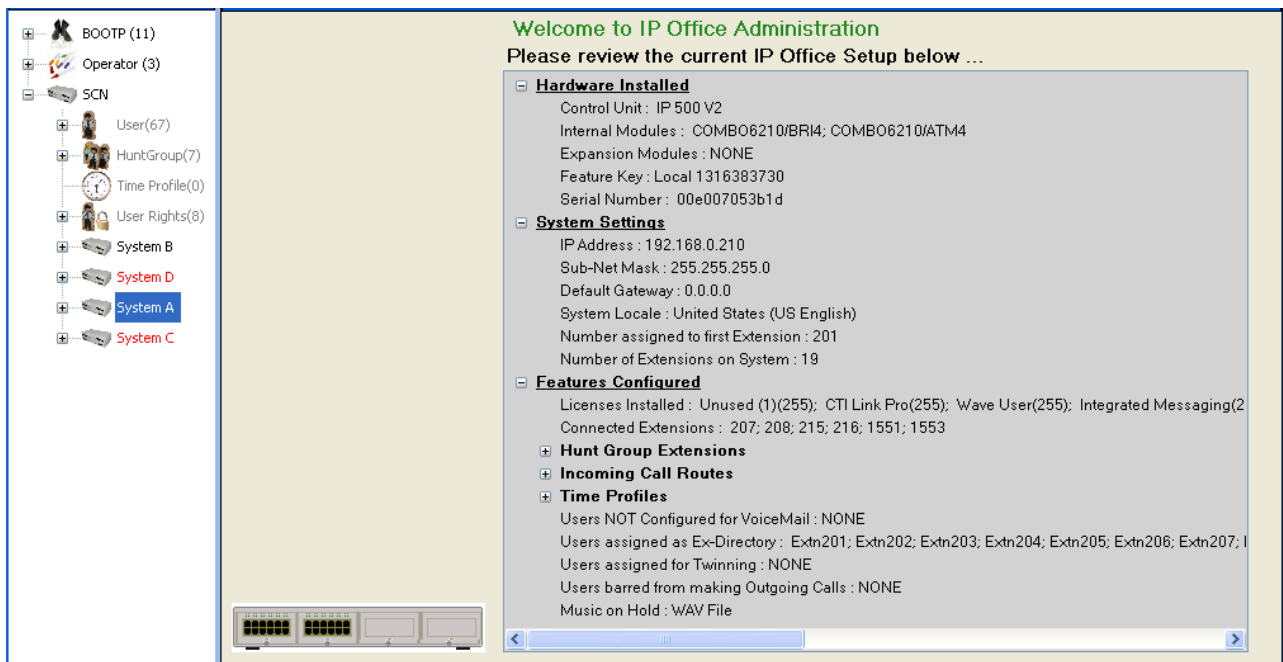

### Related links

[Small Community Network Management](#) on page 792

## Small Community Network Remote Hotdesking

The system supports hotdesking between systems within a network.

In the descriptions below, the system on which the user is configured is termed their 'home' system, all other systems are 'remote' systems.

When a user logs in to a remote system:

- The user's incoming calls are rerouted to that system.

- The user's outgoing calls uses the settings of the remote system.
- The user's license privileges move with them, for example their user profile setting is retained. The host system does not need to be licensed for the user.
- The user's own settings are transferred. However, some settings may become unusable or may operate differently.
- User rights are not transferred to the remote system but the name of any user rights associated with the user are transferred. If user rights with the same name exist on the remote system, then they will be used. The same applies for user rights applied by time profiles, if time profiles with the same name exist on the remote system .
- Appearance buttons configured for users on the home system will no longer operate.
- Various other settings may either no longer work or may work differently depending on the configuration of the remote system at which the user has logged in.
- The rights granted to the user by their **Profile** settings are retained by the user. There is no requirement for the remote system to have the appropriate licenses for the **Profile**.

If the user's home system is disconnected while the user is remotely hot desked, the user will remain remotely hot desked. They can remain in that state unless the current host system is restarted. They retain their license privileges as if they were on their home system. Note however that when the user's home system is reconnected, the user may be automatically logged back onto that system.

**Break Out Dialing** In some scenarios a hot desking user logged in at a remote system will want to dial a number using the system short codes of another system. This can be done using either short codes with the **Break Out** feature or a programmable button set to **Break Out**. This feature can be used by any user within the multi-site network but is of most use to remote hot deskers.

#### Related links

[Configuring Small Community Networking](#) on page 786

---

## Small Community Network Fallback

Each system in the Small Community Network can include one IP Office Line where the **SCN Resiliency Options** is set to **Supports Resiliency**. The system to which the IP Office Line connects is then requested to provide fallback support for selected options for the local system.

- Note that both ends of the SCN trunk connection must be set to fallback.
- On the system requesting backup, the required **SCN Resiliency Options** are selected, indicating that it is requesting backup. A single system can only request backup from one other system.
- A system providing backup can provide backup for up to 7 other systems.

Resiliency is supported on Server Edition systems for Avaya 1600 and 9600 series H.323 phones. IP500 V2 systems also support 4600 and 5600 series phones. Resiliency is configured on **Line | IP Office Line | Line** under **SCN Resiliency Options**. The options supported are:

- **Backs up my IP Phones**
- **Backs up my Hunt Groups**
- **Backs up my Voicemail**
- **Backs up my IP DECT Phones**

### Phone Resiliency

When **Backs up my IP Phones** is selected, the local system shares information about the registered phones and users on those phones with the other system. If the local system is no longer visible to the phones, the phones reregisters with the other system.

**Failback Recovery:** If the setting **System | Telephony | Telephony | Phone Failback** is set to **Automatic**, and the phone's primary gatekeeper has been up for more than 10 minutes, the system causes idle phones to perform a failback recovery to the original system.

### Notes

- Failback handover takes approximately 3 minutes. This ensure that failback is not invoked when it is not required, for example when the local system is simply being rebooted to complete a non-mergeable configuration change.
- Failback is only intended to provide basic call functionality while the cause of failback occurring is investigated and resolved. If users make changes to their settings while in failback, for example changing their DND mode, those changes will not apply after failback.
- If the fallback system is rebooted while it is providing fallback services, the fallback services are lost.
- Fallback features require that the IP devices local to each system are still able to route data to the fallback system when the local system is not available. This will typically require each system site to be using a separate data router from the system.
- When an IP Phone re-registers to a secondary IP Office on the failure of the primary control unit, the second system will allow it to operate indefinitely as a "guest", but only until the system resets. Licenses will never be consumed for a guest IP phone.
- Remote hot desking users on H323 extensions are automatically logged out.

### Related links

[Configuring Small Community Networking](#) on page 786

---

## SCN Short Code Programming

In a multi-site network, the systems automatically learn each others extension numbers and route calls appropriately. However the same does not apply to dialing of other numbers. Using short codes it is possible to have the dialing of numbers on one system to be redirected to another system and dialed there. The dialing is then matched against the short codes available on the remote system.

## Scenario

We want a short code on System A which will correctly route any 3000 range number to System B. This will allow System B group numbers to be dialed from System A. To achieve the above scenario, we will add a new system short code. By using a system short code it becomes available to all users.

## Example Short Code

In the configuration for System A.

1. Click **Short code** to display a list of existing system short codes.
2. Right-click on the displayed list and select **New**.
3. Enter the short code settings as follows:
  - **Short Code:** 3XXX This will match any four-digit number beginning with 3.
  - **Telephone Number:** . The . indicates that the short code should output the digits as dialed.
  - **Line Group ID:** 99999 This should match the Outgoing Group ID given to the IP Office Line connected to System B.
  - **Feature:** Dial

Click **OK**.

A similar system short code can be added to System B's configuration to route 2XXX dialing to System A.

## Related links

[Configuring Small Community Networking](#) on page 786

# Part 5: Short Codes

# Chapter 17: Short Code Overview

Whenever the system receives a set of digits to process, if those digits do not match a user or group extension number, the system will look for a short code match. The matching short code then defines what action (short code feature) should be applied to the call, where it should be routed and which of the dialed digits, if any, should be used in the subsequent action.

This applies to digits dialed by a telephone user, sent by a user selecting a directory contact or speed dial, and in some cases to digits received with an incoming call on a line.

This section provides an overview of short codes configuration and use.

## **Warning:**

The dialing of emergency numbers must not be blocked. Whenever short codes are edited, you must ensure that the ability of users to dial emergency numbers is tested and maintained. This is typically done by ensuring that the dialing of an emergency number always matches a user or system short code set to the **Dial Emergency** feature. If the system uses external dialing prefixes, you should also ensure that the dialing of emergency numbers including the prefix is not blocked.

## **Short Code Fields:**

Each short code has the following fields:

- **Short Code:** The digits which, if proved to be a best match to the dialed digits, trigger use of the short code. In addition to the normal dialing digits (0 to 9 plus \* and #), characters can also be used as follows:
  - Some characters have special meaning. For example, the wildcard **X** to match any single digit or **N** to match any set of digits. See [Short Code Characters](#) on page 808
  - Using characters also allows the creation of short codes which cannot be dialed from a phone but can be dialed from some applications.
- **Telephone Number:** The number used by the short code feature if needed, for example the outgoing number for a call to be passed to an external telephone line. Again special characters can be used in this field, see [Short Code Characters](#) on page 808.
- **Line Group ID:** This field is used for short codes that result in a number to be dialed, that is any short code set to one of the various **Dial** short code features. When that is the case, this field specifies the outgoing line group or ARS form to be used for the call. .
- **Feature:** This sets the action to performed by the short code. See [Short Code Features](#) on page 827.

- **Locale:** Features that transfer the call to voicemail indicate the language required. If the required set of language prompts is not available, the voicemail system will fallback to another appropriate language if possible (refer to the appropriate voicemail installation manual for details). The locale sent to the voicemail server by the system is determined in the following order of priority:
  1. **Short Code Locale:** The short code locale, if set, is used if the call is routed to voicemail using the short code.
  2. **Incoming Call Route Locale:** The incoming call route locale, if set, is used if caller is external.
  3. **User Locale:** The user locale, if set, is used if the caller is internal.
  4. **System Locale:** If no user or incoming call route locale is set, the system locale is used unless overridden by a short code locale. Systems using Embedded Voicemail, if the required set of upgraded language prompts to match the locale is not present on the system SD card, Manager will display an error. The required prompt set can be uploaded from Manager using the Add/Display VM Locales option.
- **Force Account Code:** When selected, if the short code results in the dialing of an external number, the user is prompted to enter a valid account code before the call is allowed to continue. See [Account Code Configuration](#) on page 683.
- **Force Authorisation Code:** When selected, if the short results in the dialing of an external number, the user is prompted to enter a valid authorisation code before the call is allowed to continue. See [Configuring authorization codes](#) on page 656.

### Short Code Descriptions:

The short method for describing short codes in this manual, for example **9N/Dial/.0**, indicates the settings of main short code fields, each separated by a / as follows:

- **Code:** In this case **9N**.
- **Feature:** In this case **Dial**.
- **Telephone Number:** In this case the symbol . representing all dialed digits.
- **Line Group ID:** In this case the call is sent to outgoing line group **0**.

### Examples:

- **\*17/VoicemailCollect/?U** A user dialing **\*17** is connected to their own mailbox to collect messages.
- **\*14\*N#/FollowMeTo/N** If a user dials **\*14\*210#** at their own extension, their calls are redirected to extension 210.

### Types of Short Code:

In addition to different short code features, there are different types of short code:

- **Dialing Short Codes:** The following types of short code applied to on-switch dialing. The result may be an action to be performed by the system, a change to the user's settings or a number

to be dialed. The order below is the order of priority in which they are used when applied to user dialing.

- **User Short Codes:** These are usable by the specific user only. User short codes are applied to numbers dialed by that user and to calls forwarded via the user.
- **User Rights Short Codes:** These are usable by any users associated with the user rights in which they are set. User Rights short codes are only applied to numbers dialed by that user. For example they are not applied to calls forwarded via the user.
- **System Short Codes:** These are available to all users on the system. They can be overridden by user or user rights short codes.
- **Post-Dialing Short Codes:** When any the short code above result in a number to be dialed, further short code can be applied to that number to be dialed. This is done using the following types of short codes.
  - **ARS (Alternate Route Selection) Short Codes:** The short code that matches dialing can specify that the resulting number should be passed to an ARS form. The ARS form can specify which routes should be used for the call by using further short code matches and also provide option to use other ARS forms based on other factors such as time and availability of routes.
  - **Transit Network Selection (TNS) Short Codes:** Used on T1 ISDN trunks set to use AT&T as the Provider. Applied to the digits presented following any other short code processing.
- **Incoming Number Short Codes:** On certain types of trunks short codes can be applied to the incoming digits received with calls.
  - **Line Short Codes:** These short codes are used to translate incoming digits received with calls. The stage at which they are applied varies between different line types and may be overridden by an extension number match.

#### Related links

[Short Code Characters](#) on page 808

[User Dialing](#) on page 811

[Application Dialing](#) on page 814

[Secondary Dial Tone](#) on page 814

[? Short Codes](#) on page 816

[Short Code Matching Examples](#) on page 816

[Default System Short Code List](#) on page 821

---

## Short Code Characters

The short code fields **Short Code** and **Telephone Number** can contain the normal diallable digits \*, # and 0 to 9. In addition they can also use a range of special characters as listed below.



## Short Code Field Characters

- **? = Default Match** This character can be used on its own to create a short code match in the absence of any other short code match. See Short Codes topic in *Administering Avaya IP Office™ Platform with Web Manager*.
- **?D = Default Number Dialing** This character combination makes a call to the defined phone number as soon as the user goes off-hook. See Short Codes topic in *Administering Avaya IP Office™ Platform with Web Manager*.
- **?D(x) = Default Number Dialing Timeout** The character x represents time in seconds. If a phone is off-hook or speaker is enabled and no number is dialed for x seconds, the phone makes a call to the defined phone number. A maximum of 30 seconds is used for x though system accepts values more than 30 on the interface.
- **N = Match Any Digits** Matches any dialed digits (including none). The **Dial Delay Time** or a following matching character is used to resolve when dialing is complete.
- **X = Match a Digit** Matches a single digit. When a group of X's is used, the short code matches against the total number of X's.
- **[ ] = Secondary Dial Tone Trigger** For pre-4.0 IP Office systems used to trigger secondary dial tone. Not used for Release 4.0+. See Secondary Dial Tone.
- **; = Receive Sending Complete** When used this must be the last character in the short code string.
  - If the **Dial Delay Count** is 0, a ; instructs the system to wait for the number to be fully dialed, using the **Dial Delay Time** or the user dialing #, to indicate completion and then acting on the short code.
  - If the **Dial Delay Count** is not zero, the dialing is only evaluated when # is pressed. The majority of North-American telephony services use en-bloc dialing. Therefore the use of a ; is recommended at the end of all dialing short codes that use an N before routing those calls to a trunk or ARS. This is also recommended for all dialing where secondary dial tone short codes are being used.

## Telephone Number Field Characters

- **A = Allow Outgoing CLI** Allow the calling party number sent with the call to be used. This character may be required by service providers in some locales.
- **C = Use Called Number Field** Place any following digits in the outgoing call's Called number field rather than the Keypad field.
- **D = Wait for Connect** Wait for a connect message before sending any following digits as DTMF.
- **E = Extension Number** Replace with the extension number of the dialing user. Note that if a call is forwarded this will be replaced with the extension number of the forwarding user.
- **h = Hold Music Source** When used as part of the short code telephone number field, this character allows the source for music on hold to be selected. Enter h (X) where X indicates the required hold music source if available. This overrides any previous hold music selection that may have been applied to the call.
  - For IP500 V2 systems, the value of X can be 1 to 4.
  - For systems on a Linux based server, the value of X can be 1 to 32.

- When used with Park Call short codes, the **h(X)** should be entered before the park slot number part of the telephone number.
- **I = Use Information Packet** Send data in an Information Packet rather than Set-up Packet.
- **K = Use Keypad Field** Place any following digits in the outgoing call's Keypad field rather than the Called Number field. Only supported on ISDN and QSIG.
- **I = Last Number Dialed (lower case L)** Use the last number dialed.
- **L = Last Number Received** Use the last number received.
- **N = Dialed Digit Wildcard Match** Substitute with the digits used for the **N** or **X** character match in the Short Code number field.
- **p = Priority** The priority of a call is normally assigned by the Incoming Call Route or else is **1-Low** for all other calls. Dial Extn short codes can use **p(x)** as a suffix to the **Telephone Number** to change the priority of a call. Allowable values for **x** are **1, 2** or **3** for low, medium or high priority respectively.
- In situations where calls are queued, high priority calls are placed before calls of a lower priority. This has a number of effects:
  - Mixing calls of different priority is not recommended for destinations where Voicemail Pro is being used to provide queue ETA and queue position messages to callers since those values will no longer be accurate when a higher priority call is placed into the queue. Note also that Voicemail Pro will not allow a value already announced to an existing caller to increase.
  - If the addition of a higher priority call causes the queue length to exceed the hunt group's Queue Length Limit, the limit is temporarily raised by 1. This means that calls already queued are not rerouted by the addition of a higher priority call into the queue.
- **r = Ring Tone Plan** When used as part of the short code telephone number field, this character can specify a Ring Tone Plan number. Enter **r(X)** where **X** is 1 to 8 indicating the Ring Tone Plan number to use.
- **S = Calling Number** Place any following digits into the outgoing call's calling number field. Using **S** does not alter any allow or withhold CLI setting associated with the call, the short code characters **A** or **W** should be used respectively.
  - On mobile twinned calls, if the original party information is used or a specific calling party information CLI is set, that number overrides setting the outgoing CLI using short codes.
  - Note that for SIP trunks, the SIP URI configuration options override this setting.
  - **Outgoing CLI Warning** Changing the outgoing CLI for calls requires the line provider to support that function. You must consult with your line provider before attempting to change the outgoing CLI, failure to do so may result in loss of service. If changing the outgoing CLI is allowed, most line providers required that the outgoing CLI used matches a number valid for return calls on the same trunks. Use of any other number may cause calls to be dropped or the outgoing CLI to be replaced with a valid number. On mobile twinned calls, if the original party information is used or a specific calling party information CLI is set, that number overrides setting the outgoing CLI using short codes.
- **SS = Pass Through Calling Number** Pass through the Calling Party Number. For example, to provide the incoming ICLID at the far end of a VoIP connection, a short code **?** with telephone number **.SS** should be added to the IP line.

- **i = National** Both the **S** and **SS** characters can be followed by an **i**, that is **Si** and **SSi**. Doing this sets the calling party number plan to ISDN and number type to National. This may be required for some network providers.
- **t = Allowed Call Duration** Set the maximum duration in minutes for a call plus or minus a minute. Follow the character with the number of minutes in brackets, for example **t(5)**.
- **U = User Name** Replace with the User Name of the dialing user. Used with voicemail.
- **W = Withhold Outgoing CLI** Withhold the sending of calling ID number. Operation is service provider dependent.
- **Y = Wait for Call Progress Message** Wait for a Call Progress or Call Proceeding message before sending any following digits as DTMF. For example, the Y character would be necessary at a site where they have signed up with their telephone service provider to withhold international dialing until a DTMF pin/account number is entered that initiates the call progress/proceeding message.
- **Z = Calling Party Name** This option can be used with trunks that support the sending of name information. The **Z** character should be followed by the name enclosed in " " quotation marks. Note that there may be name length restrictions that vary between line providers. The changing of name information on calls being forwarded or twinned may also not be supported by the line provider.
- **@ = Use Sub Address Field** Enter any following digits into the sub-address field.
- **. = Dialed Digits** Replace with the full set of dialed digits that triggered the short code match.
- **, = One Second Pause** Add a one second pause in DTMF dialing.
- **; = Receive Sending Complete** When used this must be the last character in the short code string. If the **Dial Delay Count** is **0**, a ; instructs the system to wait for the number to be fully dialed, using the **Dial Delay Time** or the user dialing #, to indicate completion and then acting on the short code. If the **Dial Delay Count** is not zero, the dialing is only evaluated when # is pressed.
- **" " = Non Short Code Characters** Use to enclose any characters that should not be interpreted as possible short code special characters by the system. For example characters being passed to the voicemail server.

#### Related links

[Short Code Overview](#) on page 806

---

## User Dialing

The following rules are used when short code matching is performed for user dialing:

- A short code is used immediately an exact match is found unless followed by a ;.
- If no match is found but partial matches exist, the user can continue dialing.
- If no match or partial matches are found, incompatible is returned.

- The following precedence is used to determine which short codes are used:
  - Extension number matches override all short codes.
  - User short codes override user rights and system short codes.
  - User Rights short code matches override system short codes.
- When multiple exact matches occur,
  - The match with the most specified digits rather than wildcards is used.
  - If there are still more than one match, the match with the most exact length is used. This means X wildcards will override N when both match.
- The rules above are applied even if the number is dialed by selection from a directory or using any other method of stored number dialing.

### User Digit Dialing Settings:

The following system settings influence user dialing.

**Dial Delay Count:** *Default = 0 (US/Japan), 4 (ROW)*. This value sets the number of digits dialed before the system looks for a short code match.

**Dial Delay Time:** *Default = 4 seconds (US/Japan), 1 second (ROW)*. This value sets the maximum allowed interval between the dialing of each digit. If exceeded, the system looks for a short code match even if the Dial Delay Count has not been reached.

**Off-Hook Timer:** When a user goes off-hook, the system starts a 30 second off-hook timer (10 seconds in Italy). If the off-hook timer expires before a short code match occurs, the user is disconnected.

### User Dialing Flowchart:

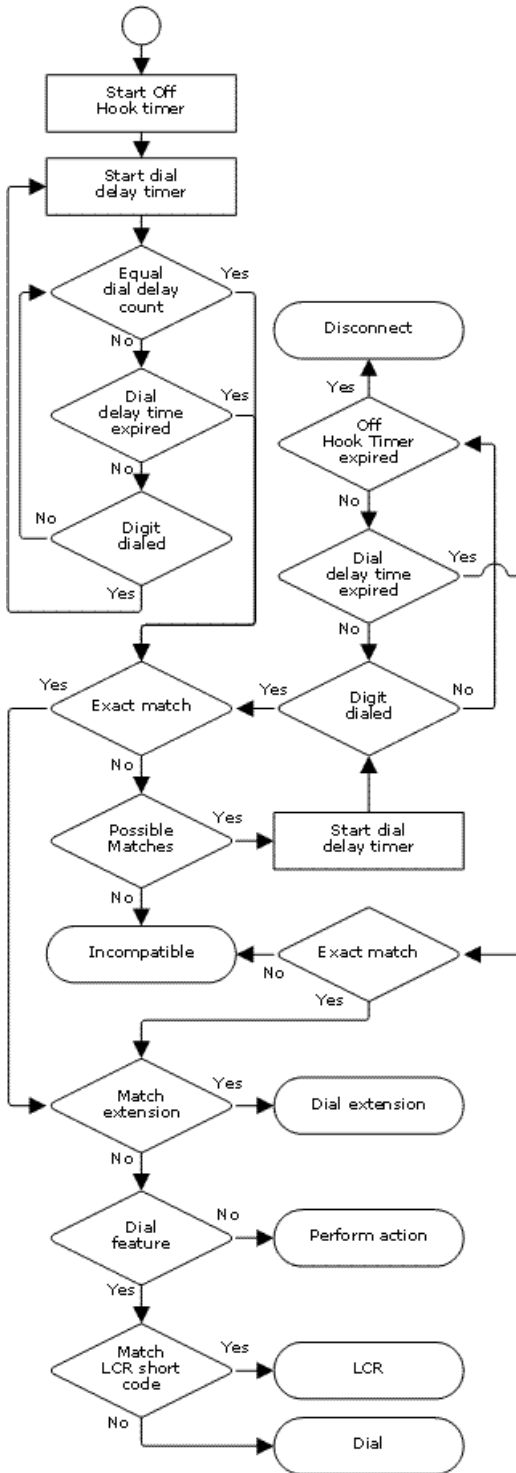

**Related links**

[Short Code Overview](#) on page 806

---

## Application Dialing

Numbers speed dialed by system applications such as SoftConsole are treated differently. Since the digits are received en bloc as a single group, they can override some short code matches. The same applies to short codes used within system configuration settings such as Incoming Call Route destinations.

Example:

- Telephone Number: 12345678
- Short Code 1: 1234XX/Dial/Extn/207
- Short Code 2: 12345678/Dial Extn/210

If dialed manually by the user, as soon as they have dialed 123456 a match to short code 1 occurs. They can never dial short code 2.

If dialed using an application, 12345678 is sent as a string and a match to short code 2 occurs.

### Partial Dialing

If the application dialing does not trigger an exact match, the user can dial additional digits through their extension. The processes for normal user dialing are applied.

### Non-Digit Short Codes

Short codes can be created that use alphabetic characters instead of numbers. While these short codes cannot be dialed from a phone, they can be dialed using application speed dials and settings. However characters that are interpreted as special short code characters will still be interpreted as such.

### Related links

[Short Code Overview](#) on page 806

---

## Secondary Dial Tone

Some locales prefer to provide users with secondary dial tone once they have started dialing external calls. This dial tone is heard by the user until they have completed dialing and a trunk is seized at which point call progress tones are provided by the trunk, or camp on/busy tone is provided by the system if the required trunk cannot be seized.

### Release 4.0 and Higher

The use of secondary dial tone is provided through the **Secondary Dial Tone** check box option on the ARS form to which the call is routed. When on, this setting instructs the system to play secondary dial tone to the user.

The tone used is set as either **System Tone** (normal dial tone) or **Network Tone** (secondary dial tone). Both tone types are generated by the system in accordance with the system specific locale setting. Note that in some locales normal dial tone and secondary dial tone are the same.

When **Secondary Dial Tone** is selected, the ARS form will return tone until it receives digits with which it can begin short code matching. Those digits can be the result of user dialing or digits passed by the short code which invoked the ARS form. For example with the following system short codes:

In this example, the 9 is stripped from the dialed number and is not part of the telephone number passed to the ARS form. So in this case secondary dial tone is given until the user dials another digit or dialing times out.

- **Code:** 9N
- **Telephone Number:** N
- **Line Group ID:** 50 Main

In this example, the dialed 9 is included in the telephone number passed to the ARS form. This will inhibit the use of secondary dial tone even if secondary dial tone is selected on the ARS form.

- **Code:** 9N
- **Telephone Number:** 9N
- **Line Group ID:** 50 Main

#### Pre-4.0 IP Office Secondary Dial Tone

Pre-4.0 systems provided dial tone through the use of the short code feature Secondary Dial Tone and the [ ] special characters. For example, on a system where 9 is used as a prefix for external dialing, the system short code 9./Secondary Dial Tone/0 will trigger secondary dial tone when users dial a number prefixed with 9. This method is not supported by Release 4.0 which provides ARS forms for the control of outgoing calls.

In order to allow further digit matching, the digits dialed are put back through short code matching against any short codes that start with [n] where n is the digit used to trigger the system secondary dial tone short code.

On all systems where secondary dial tone is used, a ; should also be used in dialing short codes that contain N.

For example:

#### System Short Codes

- 9/SecondaryDialTone/.
- [9]0N;/Dial/0

#### User Short Code

[9]0N;/Busy/0

The user dials 90114445551234. The 9 matches the system secondary dial tone short code and unlike other short codes this is applied immediately. The user's dialing is put through short code matching again using the normal order of precedence but matched to possible short codes beginning [9]. In this case the user's [9]0N; short code would take precedence over the system [9]0N; short code.

## Related links

[Short Code Overview](#) on page 806

---

## ? Short Codes

The ? character can be used in short codes in the following ways:

### Default Short Code Matching:

? short codes are used in short code matching in the following way. If no user or system short code match is found, the system will then look for a ? short code match. It will look first for a user ? short code and then, if not found, a system ? short code.

Example: On systems outside North America, the system short code **?/Dial/.0** is added as a default short code. This short code provides a match for any dialing to which there is no other match. Therefore, on systems with this short code, the default is that any unrecognized number will be dialed to Outgoing Line Group 0.

### Hot-Line Dialing:

A user short code **?D** can be used to perform a short code action immediately the user extension goes off-hook. This is supported with Dial type short code features. Typically it is used with door, lift and lobby phones to immediately connect the phone to a number such as the operator or reception.

### Voicemail Collect Short Codes:

The ? character can appear in the **Telephone Number** field of a short code. This is done with short codes using the VoicemailCollect feature. In this instance the ? character is not interpreted by the system, it is used by the voicemail server.

## Related links

[Short Code Overview](#) on page 806

---

## Short Code Matching Examples

The following examples are not meant as practical examples. However they are simple to implement and test on real system without conflicting with its normal operation. They illustrate the interaction between different short codes in resolving which short code is an exact match. They assume that extension numbers are in the 200 to 299 range.

The term 'dials' means dialing the indicated digit or digits without the inter-digit Dial Delay Time expiring.

The term 'pause' means a wait that exceeds the inter-digit Dial Delay Time.



Scenario 1		
Short Code 1 = 60/Dial Extn/203		
Dial Delay Count = 0. Dial Delay Time = 4 seconds.		
Test	Dialing	Effect
1	8	No possible match, incompatible returned immediately
2	6	No exact match but there is a potential match, so the system waits. When the Dial Delay Time expires, no exact match is found so incompatible is returned.
3	60	Exact match to Short Code 1. Extension 203 called immediately.
4	61	No possible match, the system returns incompatible.

Scenario 2		
Short Code 1 = 60/Dial Extn/203		
Short Code 2 = 601/Dial Extn/210		
Dial Delay Count = 0. Dial Delay Time = 4 seconds.		
Test	Dialing	Effect
1	8	No possible match, incompatible returned immediately
2	60	Exact match to Short Code 1. Extension 203 called immediately.
3	601	Exact match to Short Code 1 as soon as the 0 is dialed. The user cannot manually dial 601.

Scenario 3		
Short Code 1 = 60/Dial Extn/203		
Short Code 2 = 601/Dial Extn/210		
Dial Delay Count = 3. Dial Delay Time = 4 seconds.		
Test	Dialing	Effect
1	8	Insufficient digits to trigger matching. The system waits for additional digits or for Dial Delay Time to expire. When Dial Delay Time expires, no possible match is found so incompatible is returned.

*Table continues...*

## Short Code Overview

2	60	Insufficient digits to trigger matching. The system waits for additional digits or for Dial Delay Time to expire. When Dial Delay Time expires, matching started and exact match to Short Code 1 occurs. .
3	601	Third digit triggers matching. Exact match to Short Code 2. Extension 210 dialed immediately.
4	60#	# is treated as a digit and as the third digit triggers matching. No exact match found. The system returns incompatible.

Scenario 4		
Short Code 1 = 60;/Dial Extn/203		
Short Code 2 = 601/Dial Extn/210		
Dial Delay Count = 3. Dial Delay Time = 4 seconds.		
Test	Dialing	Effect
1	8	Insufficient digits to trigger matching. The system waits for additional digits or for Dial Delay Time to expire. When Dial Delay Time expires, no possible match is found so incompatible is returned.
2	6	Insufficient digits to trigger matching. The system waits for additional digits or for the interdigit Dial Delay Time to expire. If the Dial Delay Time expires, a potential match exists to a short code that uses ; so the system waits for an additional digit until the off-hook timer expires.

*Table continues...*

3	60	<p>As above but an additional digit now may create a match.</p> <p>If 1 is dialed, it creates an exact match to Short Code 2 and is used immediately.</p> <p>If 0, * or 2 to 9 is dialed, no possible match exists. The system returns incompatible.</p> <p>If the next digit is a #, it is treated as signaling dialing complete rather than being a digit. Short code 1 becomes an exact match and is used immediately.</p>
4	601	<p>Third digit triggers matching. Exact match to Short Code 2. Extension 210 dialed immediately.</p>

Scenario 5		
Short Code 1 = 601/Dial Extn/203		
Short Code 2 = 60N/Dial Extn/210		
Dial Delay Count = 0. Dial Delay Time = 4 seconds.		
Test	Dialing	Effect
1	6	No exact match but there is a potential match, so the system waits for additional dialing. If the Dial Delay Time expires, no exact match is found so incompatible is returned.
2	60	Potential match to both short codes. The system waits for additional dialing. If the Dial Delay Time expires, Short Code 2 becomes an exact match with N blank.
3	601	Exact match to Short Code 1. Used immediately
4	602	Exact match to Short Code 2. Used immediately.

Scenario 6
------------

*Table continues...*

Short Code Overview

Short Code 1 = 601/Dial Extn/203 Short Code 2 = 60N/Dial Extn/210 Short Code 3 = 60X/Dial Extn/207 Dial Delay Count = 0. Dial Delay Time = 4 seconds.		
Test	Dialing	Effect
1	6	No exact match but there are potential matches so the system waits for additional dialing. If the Dial Delay Time expires, no exact match has occurred so incompatible is returned.
2	60	Potential match to all short codes. System waits for additional dialing. If the Dial Delay Time expires, Short Code 2 becomes an exact match with N blank. If a digit is dialed, Short Code 3 becomes a more exact match and is used.
3	601	Exact match all short code, however Short Code 1 is treated as being more exact (more matching digits) and is used immediately
4	602	Exact match to short codes 2 and 3, however the Short Code 3 is treated as being more exact (length match) and is used immediately.

Scenario 7 Short Code 1 = 601/Dial Extn/203 Short Code 2 = 60N/Dial Extn/210 Short Code 3 = 6XX/Dial Extn/207 Dial Delay Count = 0. Dial Delay Time = 4 seconds.		
Test	Dialing	Effect
1	6	No exact match but there are potential matches so the system waits for additional dialing. If the Dial Delay Time expires, no exact match has occurred so incompatible is returned.

*Table continues...*

2	60	Potential match to all short codes. System waits for additional dialing. If the Dial Delay Time expires, Short Code 2 becomes an exact match with N blank. If a digit is dialed, Short Code 3 becomes an more exact match and is used.
3	601	Exact match all short code, however Short Code 1 is treated as being more exact (more matching digits) and is used immediately
4	602	Exact match to short codes 2 and 3, however the Short Code 2 is treated as being more exact (more matching digits) and is used immediately.
5	612	Exact match to Short Code 3.

**Related links**

[Short Code Overview](#) on page 806

---

## Default System Short Code List

Most control units are available in A-Law and U-Law models. Typically U-Law models are supplied to North American locales, A-Law models are supplied to the rest of the world. In addition to the using different default companding for digital lines and phone, A-Law and U-Law models support different default short codes. The following table lists the default system short codes present in a system's configuration.

**Standard Mode**

Short Code	Telephone Number	Feature	A-Law	ULAW
*00	Blank	Cancel All Forwarding	✓	✓
*01	Blank	Forward Unconditional On	✓	✓
*02	Blank	Forward Unconditional Off	✓	✓
*03	Blank	Forward On Busy On	✓	✓

*Table continues...*

Short Code Overview

Short Code	Telephone Number	Feature	A-Law	ULAW
*04	Blank	Forward On Busy Off	✓	✓
*05	Blank	Forward On No Answer On	✓	✓
*06	Blank	Forward On No Answer Off	✓	✓
*07*N#	N	Forward Number	✓	✓
*08	Blank	Do Not Disturb On	✓	✓
*09	Blank	Do Not Disturb Off	✓	✓
*10*N#	N	Do Not Disturb Exception Add	✓	✓
*11*N#	N	Do Not Disturb Exception Del	✓	✓
*12*N#	N	Follow Me Here	✓	✓
*13*N#	N	Follow Me Here Cancel	✓	✓
*14*N#	N	Follow Me To	✓	✓
*15	Blank	Call Waiting On	✓	✓
*16	Blank	Call Waiting Off	✓	✓
*17	?U	Voicemail Collect	✓	✓
*18	Blank	Voicemail On	✓	✓
*19	Blank	Voicemail Off	✓	✓
*20*N#	N	Set Hunt Group Night Service	✓	✓
*21*N#	N	Clear Hunt Group Night Service	✓	✓
*22*N#	N	Suspend Call	✓	✗
*23*N#	N	Resume Call	✓	✗
*24*N#	N	Hold Call	✓	✗
*25*N#	N	Retrieve Call	✓	✗
*26		Clear CW	✓	✗
*27*N#	N	Hold CW	✓	✗
*28*N#	N	Suspend CW	✓	✗
*29	Blank	Toggle Calls	✓	✓
*30	Blank	Call Pickup Any	✓	✓
*31	Blank	Call Pickup Group	✓	✓
*32*N#	N	Call Pickup Extn	✓	✓

Table continues...

Short Code	Telephone Number	Feature	A-Law	ULAW
*33*N#	N	Call Queue	✓	✓
*34N;	N	Hold Music	✓	✓
*35*N#	N	Extn Login	✓	✓
*36	Blank	Extn Logout	✓	✓
*37*N#	N	Call Park	✓	✓
*38*N#	N	Unpark Call	✓	✓
*39	1	Relay On	✓	✓
*40	1	Relay Off	✓	✓
*41	1	Relay Pulse	✓	✓
*42	2	Relay On	✓	✓
*43	2	Relay Off	✓	✓
*44	2	Relay Pulse	✓	✓
*45*N#	N	Acquire Call	✓	✓
*46	Blank	Acquire Call	✓	✓
*47	Blank	Conference Add	✓	✓
*48	Blank	Voicemail Ringback On	✓	✓
*49	Blank	Voicemail Ringback Off	✓	✓
*50	Blank	Forward Huntgroup On	✓	✓
*51	Blank	Forward Huntgroup Off	✓	✓
*52	Blank	Cancel or Deny	✓	✓
*53*N#	N	Call Pickup Members	✓	✓
*55	Blank	Stamp Log	✓	✓
*57*N#	N	Forward On Busy Number	✓	✓
*70	Blank	Call Waiting Suspend	✓	✗
*70*N#	N	Dial Physical Extn by Number	✗	✓
*71*N#	N	Dial Physical Extn by Id	✗	✓
*9000*	"MAINTENANCE"	Relay On	✓	✓
*91N;	N".1"	Record Message	✓	✓

Table continues...

## Short Code Overview

Short Code	Telephone Number	Feature	A-Law	ULAW
*92N;	N".2"	Record Message	✓	✓
*99;	"edit_messages"	Voicemail Collect	✓	✓
9N	N	Dial	✗	✓
?	.	Dial	✓	✗

## Server Edition

Short Code	Telephone Number	Feature	A-Law	ULAW
*00	Blank	Cancel All Forwarding	✓	✓
*01	Blank	Forward Unconditional On	✓	✓
*02	Blank	Forward Unconditional Off	✓	✓
*03	Blank	Forward On Busy On	✓	✓
*04	Blank	Forward On Busy Off	✓	✓
*05	Blank	Forward On No Answer On	✓	✓
*06	Blank	Forward On No Answer Off	✓	✓
*07*N#	N	Forward Number	✓	✓
*08	Blank	Do Not Disturb On	✓	✓
*09	Blank	Do Not Disturb Off	✓	✓
*10*N#	N	Do Not Disturb Exception Add	✓	✓
*11*N#	N	Do Not Disturb Exception Del	✓	✓
*12*N#	N	Follow Me Here	✓	✓
*13*N#	N	Follow Me Here Cancel	✓	✓
*14*N#	N	Follow Me To	✓	✓
*17	?U	Voicemail Collect	✓	✓
*18	Blank	Voicemail On	✓	✓
*19	Blank	Voicemail Off	✓	✓
*20*N#	N	Set Hunt Group Night Service	✓	✓

Table continues...



Short Code	Telephone Number	Feature	A-Law	ULAW
*21*N#	N	Clear Hunt Group Night Service	✓	✓
*29	Blank	Toggle Calls	✓	✓
*30	Blank	Call Pickup Any	✓	✓
*31	Blank	Call Pickup Group	✓	✓
*32*N#	N	Call Pickup Extn	✓	✓
*33*N#	N	Call Queue	✓	✓
*34N;	N	Hold Music	✓	✓
*35*N#	N	Extn Login	✓	✓
*36	Blank	Extn Logout	✓	✓
*37*N#	N	Call Park	✓	✓
*38*N#	N	Unpark Call	✓	✓
*44	2	Relay Pulse	✓	✓
*45*N#	N	Acquire Call	✓	✓
*46	Blank	Acquire Call	✓	✓
*47	Blank	Conference Add	✓	✓
*48	Blank	Voicemail Ringback On	✓	✓
*49	Blank	Voicemail Ringback Off	✓	✓
*50	Blank	Forward Huntgroup On	✓	✓
*51	Blank	Forward Huntgroup Off	✓	✓
*52	Blank	Cancel or Deny	✓	✓
*53*N#	N	Call Pickup Members	✓	✓
*55	Blank	Stamp Log	✓	✓
*57*N#	N	Forward On Busy Number	✓	✓
*66*N#	N	Conference Meet Me	✓	✓
*70	Blank	Call Waiting Suspend	✓	✗
*70*N#	N	Dial Physical Extn by Number	✗	✓
*71*N#	N	Dial Physical Extn by Id	✗	✓

Table continues...

## Short Code Overview

Short Code	Telephone Number	Feature	A-Law	ULAW
<b>*99;</b>	"edit_messages"	Voicemail Collect	✓	✓
<b>9N</b>	N	Dial	✗	✓ [1]
<b>?</b>	.	Dial	✓	✓ [1]

For U-Law systems, a **9N** is a default short code on the Primary Server while a **?** short code is a default on all other servers.

Additional short codes of the form \*DSSN, \*SDN, \*SKN, these are used by the system for internal functions and should not be removed or altered. Short codes \*#N and \*\*N may also be visible, these are used for ISDN functions in Scandinavian locales.

The default **\*34** short code for music on hold has changed to **\*34N**;

### Related links

[Short Code Overview](#) on page 806

# Chapter 18: Short Code Features

Note that this document describes all existing short codes. The short codes available in the Manager application depends on the software release.

## Related links

[Auto Attendant](#) on page 830  
[Auto Intercom Deny Off](#) on page 831  
[Auto Intercom Deny On](#) on page 831  
[Break Out](#) on page 832  
[Barred](#) on page 832  
[Busy On Held](#) on page 833  
[Call Intrude](#) on page 834  
[Call Listen](#) on page 834  
[Call Park](#) on page 836  
[Call Park and Page](#) on page 837  
[Call Pickup Any](#) on page 837  
[Call Pickup Extn](#) on page 838  
[Call Pickup Group](#) on page 838  
[Call Pickup Line](#) on page 839  
[Call Pickup Members](#) on page 840  
[Call Pickup User](#) on page 840  
[Call Queue](#) on page 841  
[Call Record](#) on page 842  
[Call Steal](#) on page 842  
[Call Waiting On](#) on page 843  
[Call Waiting Off](#) on page 844  
[Call Waiting Suspend](#) on page 844  
[Cancel All Forwarding](#) on page 845  
[Cancel Ring Back When Free](#) on page 845  
[Change Login Code](#) on page 846  
[Clear After Call Work](#) on page 847  
[Clear Call](#) on page 847  
[Clear CW](#) on page 848  
[Clear Hunt Group Night Service](#) on page 848  
[Clear Hunt Group Out Of Service](#) on page 849

[Clear Quota](#) on page 850  
[Coaching Intrusion](#) on page 850  
[Conference Add](#) on page 851  
[Conference Meet Me](#) on page 852  
[CW](#) on page 853  
[Dial](#) on page 854  
[Dial 3K1](#) on page 855  
[Dial 56K](#) on page 855  
[Dial 64K](#) on page 856  
[Dial CW](#) on page 856  
[Dial Direct](#) on page 857  
[Dial Direct Hot Line](#) on page 857  
[Dial Emergency](#) on page 858  
[Dial Extn](#) on page 858  
[Dial Fax](#) on page 859  
[Dial Inclusion](#) on page 860  
[Dial Paging](#) on page 861  
[Dial Physical Extension by Number](#) on page 861  
[Dial Physical Extension By ID](#) on page 862  
[Dial Speech](#) on page 862  
[Dial V110](#) on page 863  
[Dial V120](#) on page 863  
[Dial Video](#) on page 863  
[Disable ARS Form](#) on page 864  
[Disable Internal Forwards](#) on page 864  
[Disable Internal Forward Unconditional](#) on page 865  
[Disable Internal Forward Busy or No Answer](#) on page 865  
[Display Msg](#) on page 866  
[Do Not Disturb Exception Add](#) on page 867  
[Do Not Disturb Exception Delete](#) on page 867  
[Do Not Disturb On](#) on page 868  
[Do Not Disturb Off](#) on page 869  
[Enable ARS Form](#) on page 869  
[Enable Internal Forwards](#) on page 870  
[Enable Internal Forward Unconditional](#) on page 870  
[Enable Internal Forward Busy or No Answer](#) on page 871  
[Extn Login](#) on page 871  
[Extn Logout](#) on page 872  
[Flash Hook](#) on page 873  
[FNE Service](#) on page 874  
[Follow Me Here](#) on page 874

[Follow Me Here Cancel](#) on page 875  
[Follow Me To](#) on page 875  
[Forward Hunt Group Calls On](#) on page 876  
[Forward Hunt Group Calls Off](#) on page 877  
[Forward Number](#) on page 877  
[Forward On Busy Number](#) on page 878  
[Forward On Busy On](#) on page 879  
[Forward On Busy Off](#) on page 879  
[Forward On No Answer On](#) on page 880  
[Forward On No Answer Off](#) on page 880  
[Forward Unconditional On](#) on page 881  
[Forward Unconditional Off](#) on page 882  
[Group Listen Off](#) on page 882  
[Group Listen On](#) on page 883  
[Headset Toggle](#) on page 883  
[Hold Call](#) on page 884  
[Hold CW](#) on page 885  
[Hold Music](#) on page 885  
[Hunt Group Disable](#) on page 886  
[Hunt Group Enable](#) on page 886  
[Last Number Redial](#) on page 887  
[MCID Activate](#) on page 887  
[Mobile Twinned Call Pickup](#) on page 888  
[Off Hook Station](#) on page 889  
[Outgoing Call Bar Off](#) on page 889  
[Outgoing Call Bar On](#) on page 890  
[Private Call Off](#) on page 891  
[Private Call On](#) on page 891  
[Priority Call](#) on page 892  
[Record Message](#) on page 892  
[Relay On](#) on page 893  
[Relay Off](#) on page 894  
[Relay Pulse](#) on page 895  
[Resume Call](#) on page 895  
[Retrieve Call](#) on page 896  
[Ring Back When Free](#) on page 896  
[Secondary Dial Tone](#) on page 897  
[Set Absent Text](#) on page 898  
[Set Account Code](#) on page 899  
[Set Authorization Code](#) on page 900  
[Set Fallback Twinning Off](#) on page 900

- [Set Fallback Twinning On](#) on page 900
- [Set Hunt Group Night Service](#) on page 901
- [Set Hunt Group Out Of Service](#) on page 902
- [Set Inside Call Seq](#) on page 902
- [Set Mobile Twinning Number](#) on page 903
- [Set Mobile Twinning On](#) on page 904
- [Set Mobile Twinning Off](#) on page 904
- [Set No Answer Time](#) on page 904
- [Set Outside Call Seq](#) on page 905
- [Set Ringback Seq](#) on page 906
- [Set Time Profile](#) on page 906
- [Set Wrap Up Time](#) on page 908
- [Speed Dial](#) on page 909
- [Shutdown Embedded Voicemail](#) on page 909
- [Stamp Log](#) on page 910
- [Startup Embedded Voicemail](#) on page 910
- [Suspend Call](#) on page 911
- [Suspend CW](#) on page 911
- [Start After Call Work](#) on page 912
- [Toggle Calls](#) on page 912
- [Unpark Call](#) on page 913
- [Voicemail Collect](#) on page 913
- [Voicemail Node](#) on page 916
- [Voicemail On](#) on page 916
- [Voicemail Off](#) on page 917
- [Voicemail Ringback On](#) on page 918
- [Voicemail Ringback Off](#) on page 918
- [Whisper Page](#) on page 919

---

## Auto Attendant

This feature is used with Embedded Voicemail. It is not supported by Server Edition. It allows the recording of the greetings used by auto-attendant services and the transfer of calls to that auto attendant. This feature was previously called **Record Greeting**.

### Details

**Telephone Number:** ✓

Four system short codes (**\*81XX**, **\*82XX**, **\*83XX** and **\*84XX**) are automatically added for use with all auto attendants, for the morning, afternoon, evening and menu options greetings respectively.

These use a telephone number of the form "**AA:" N" . Y "** where **N** is the replaced with the auto attendant number dialed and **Y** is 1, 2, 3 or 4 for the morning, afternoon, evening or menu option greeting.

- An additional short code of the form (for example) **\*80XX/Auto Attendant/"AA:"N** can be added manual if internal dialed access to auto attendants is required.
- To add a short code to access a specific auto attendant, the name method should be used.
- For IP Office deployed in a Enterprise Branch environment, the short codes \*800XX, \*801XX...\*809XX, \*850XX, and \*851XX are automatically created for recording a Page prompt.

**Default Short Code:** ✓ See Configuration Settings | Auto Attendant.

**Programmable Button Control:** ✗

**Release:** 2.0+.

#### Related links

[Short Code Features](#) on page 827

## Auto Intercom Deny Off

### Details

**Telephone number:** ✗

**Default short code:** ✗

**Programmable Button Control:** ✓ Auto Intercom Deny Off

#### Related links

[Short Code Features](#) on page 827

## Auto Intercom Deny On

### Details

**Telephone number:** ✗

**Default short code:** ✗

**Programmable Button Control:** ✓ Auto Intercom Deny On

#### Related links

[Short Code Features](#) on page 827

---

## Break Out

This feature is usable within a system multi-site network. It allows a user on one system in the network to specify that the following dialing be processed by another system on the network as if the user dialed it locally on that other system. Pre-Release 5.0: This feature requires the IP Offices to have **Advanced Small Community Networking** licenses.

Details

**Telephone Number:** The IP Address or Name of the system, using \* characters in place of . characters.

**Default Short Code:** ✘

**Programmable Button Control:** BkOut

**Release:** 4.0+.

**Example** On a system, to break out via a system called RemoteSwitch with the IP Address 192.168.42.3, either of the following short codes could be used.

### Example 1

**Code:** \*80\*N#

**Telephone Number:** N

**Feature:** Break Out

### Example 2

**Code:** \*81

**Telephone Number:** RemoteSwitch

**Feature:** Break Out

Example 1 allows break out using any remote switch by dialing its IP address, for example \*80\*192\*168\*42\*3#. Example 2 does this for a specific remote system by dialing just \*81.

### Related links

[Short Code Features](#) on page 827

---

## Barred

This short code feature can be used for call barring by using the short code as the call destination. This short code feature was previously called **Busy**. It has been renamed but its function has not changed.

When used in an ARS form that has been configured with an Alternate Route, for callers whose dialing has matched the short code no further routing is applied.



#### Details

**Telephone Number:** ✘

**Default Short Code:** ✘

**Programmable Button Control:** ✘

**Release:** 1.0+.

#### Related links

[Short Code Features](#) on page 827

---

## Busy On Held

When on, busy on held returns busy to new calls when the user has an existing call on hold. This short code feature is useful when a user does not want to be distracted by an additional incoming call when they have a call on hold.

#### Details

**Telephone Number:** ✔ Y or 1 for on, N or 0 for off.

**Default Short Code:** ✘

**Programmable Button Control:** ✔ BusyH

**Release:** 1.0+.

#### Example: Turning Busy on Held on

If on, when the user has a call on hold, new calls receive busy tone (ringing if analog) or are diverted to Voicemail if enabled, rather than ringing the user.

#### **Note:**

This overrides call waiting when the user has a call on hold.

**Short Code:** \*12

**Telephone Number:** Y

**Feature:** BusyOnHeld

Example: Turning Busy on Held off

Another short code must be created to turn the Busy on Held feature off. If off, when the user has a call on hold, new calls will still get directed to the user.

**Short Code:** \*13

**Telephone Number:** N

**Feature:** BusyOnHeld

#### Related links

[Short Code Features](#) on page 827

---

## Call Intrude

This feature allows you to intrude on the existing connected call of the specified target user. All call parties are put into a conference and can talk to and hear each other. A **Call Intrude** attempt to a user who is idle becomes a Priority Call.

The ability to intrude and be intruded is controlled by two configuration settings, the Can Intrude (User | Telephony | Supervisor Settings) setting of the user intruding and the Cannot Be Intruded (User | Telephony | Supervisor Settings) setting of target being intruded on. The setting of any other internal party is ignored. By default, no users can intrude and all users are set to cannot be intruded.

Note that this feature requires conference resources from the system for the duration of the intrusion.

Users can use privacy features that to indicate that a call cannot be intruded on. See Private Calls.

Intruding onto a user doing silent monitoring ([Call Listen](#) on page 834) is turned into a silent monitoring call.

The system support a range of other call intrusion methods in addition to this feature.

### Details

**Telephone Number:** ✓ Target extension number.

**Default Short Code:** ✗

**Programmable Button Control:** ✓ Intru

**See also:** [Call Listen](#) on page 834, [Coaching Intrusion](#) on page 850, [Dial Inclusion](#) on page 860, [Whisper Page](#) on page 919.

**Release:** 1.0+.

### Related links

[Short Code Features](#) on page 827

---

## Call Listen

This feature allows you to monitor another user's call without being heard. Monitoring can be accompanied by a tone heard by all parties. Use of the tone is controlled by the Beep on Listen setting on the System | Telephony | Tones & Music tab. The default for this setting is on. If enabled, this is the only indication of monitoring given to the monitored user. There is no phone display indication of monitoring.

### Warning:

The use of features to listen to a call without the other call parties being aware of that monitoring may be subject to local laws and regulations. Before enabling the feature you must

ensure that you have complied with all applicable local laws and regulations. Failure to do so may result in severe penalties.

The use of call listen is dependant on:

The target being a member of the group set as the user's Monitor Group (User | Telephony | Supervisor Settings). The user does not have to be a member of the group.

The ability to intrude and be intruded is controlled by two configuration settings, the Can Intrude (User | Telephony | Supervisor Settings) setting of the user intruding and the Cannot Be Intruded (User | Telephony | Supervisor Settings) setting of target being intruded on. The setting of any other internal party is ignored. By default, no users can intrude and all users are set to cannot be intruded.

This feature uses system conference resources. If insufficient conference resource are available it will not be possible to use this feature.

A number of features are supported for call listening:

- Users can be given privacy features that allow them to indicate that a call cannot be monitored. See Private Calls.
- IP extensions can be monitored including those using direct media. Previously the monitoring of IP extensions could not be guaranteed.
- The monitoring call can be initiated even if the target user is not currently on a call and remains active until the monitoring user clears the monitoring call.
- The user who initiated the call listen can also record the call.

Intruding onto a user doing silent monitoring (Call Listen) is turned into a silent monitoring call.

1400, 1600, 9500 and 9600 Series phones with a user button can initiate listening using that button if the target user meets the criteria for listening.

The system support a range of other call intrusion methods in addition to this feature.

### Details

**Telephone Number:** ✓ Target extension number (extension must be local).

**Default Short Code:** ✗

**Programmable Button Control:** ✓ Listn

**See also:** [Call Intrude](#) on page 834, [Coaching Intrusion](#) on page 850, [Dial Inclusion](#) on page 860, [Whisper Page](#) on page 919.

**Release:** 1.0+.

Example

User 'Extn205' wants to be able to monitor calls received by members of the Hunt Group 'Sales'.

1. For user 'Extn205', in the Monitor Group (User | Telephony | Supervisor Settings) list box select the hunt group.

2. Ensure that **Can Intrude** is checked.
3. Create a user short code to allow Extn205 to start monitoring.
  - **Short Code:** \*89\*N#
  - **Telephone Number:** N
  - **Line Group ID:** 0.
  - **Feature:** CallListen
4. For each member of the hunt group, check that their **Cannot be Intruded** setting is unchecked.
5. Now when a member of the 'Sales' hunt group is on a call, Extn205 can replace N in the short code with the extension number of that member and monitor their call.

### Related links

[Short Code Features](#) on page 827

---

## Call Park

Parks the user's current call into the specified park slot number. The call can then be retrieved by other extensions (refer to the appropriate telephone user guide). While parked the caller hears music on hold if available. The 'Unpark Call' feature can be used to retrieve calls from specific park slots.

Park Timeout (System | Telephony | Telephony) controls how long a call will remain parked. When this expires the call will recall to the parking user if they are idle or when they next become idle. The recall call will continue ring and does follow any forwards or go to voicemail.

### Details

**Telephone Number:** ✓ Park slot number. If no park slot number is specified when this short code is used, the system automatically assigns a park slot number based on the extension number of the user parking the call plus one digit 0 to 9.

Park slot IDs can be up to 9 digits in length. Names can also be used for application park slots.

**Default Short Code:** ✓ \*37\*N#

**Programmable Button Control:** ✓ Call Park

**See also:** Unpark Call.

**Release:** 1.0+.

### Example

This short code is a default within the system configuration. This short code can be used to toggle the feature on/off. N represents the park slot number in which the call will be parked. For example, if a user wants to park a call to slot number 9, the user would dial \*37\*9#. The call will be parked there until retrieved by another extension or the original extension.

**Short Code:** \*37\*N#

**Telephone Number:** N

**Feature:** ParkCall

#### Related links

[Short Code Features](#) on page 827

---

## Call Park and Page

Parks the user's current call into the highest park slot number within the range specified on the **System | Telephony | Park & Page** tab, in the **Central Park Range** field. For example, if the specified **Central Park Range** is 1XX, then the Park & Page short code would attempt to Park on 199. If the range is 567XX, then the call would attempt to Park on 56799.

Call Park and Page via short code is primarily useful for phones with no display, or phones on which a Call Park operation is seldom performed. It provides a way for the user to Central Park in a pre-known location. If the highest Central Park slot is already in use, then the short code Call Park and Page attempt will not be successful.

In order to perform a Page after a successful Call Park via short code, the user must enter a valid Page short code.

Details

**Telephone Number:** ✘

**Default Short Code:** ✘

**Programmable Button Control:** ✔ Call Park and Page

**Release:** 9.0+.

#### Related links

[Short Code Features](#) on page 827

---

## Call Pickup Any

Pick up the first available ringing call.

Details

**Telephone Number:** ✘

**Default Short Code:** ✔ \*30

**Programmable Button Control:** ✔ PickA

**See also:** Call Pickup Extn, Call Pickup Group, Call Pickup Members, Acquire Call, Call Pickup Line, Call Pickup User.

**Release:** 1.0+.

Example

Below is an example of the short code setup:

- **Short Code:** \*30
- **Feature:** CallPickupAny

#### Related links

[Short Code Features](#) on page 827

---

## Call Pickup Extn

Pick up a ringing call from a specific extension.

Details

**Telephone Number:** ✓ Target extension number.

**Default Short Code:** ✓ \*32\*N#

**Programmable Button Control:** ✓ CpkUp

**See also:** Call Pickup Any, Call Pickup Group, Call Pickup Members, Acquire Call, Call Pickup Line, Call Pickup User.

**Release:** 1.0+.

Example

This short code is a default within the system configuration. N represents the specific extension. For example, if a user dials \*32\*201#, they will pick up the call coming into extension 201.

**Short Code:** \*32\*N#

**Telephone Number:** N

**Feature:** CallPickupAny

#### Related links

[Short Code Features](#) on page 827

---

## Call Pickup Group

Pick up a call ringing any hunt group of which the user is a member. The user can use this feature even if their membership of the group is currently set as disabled.

Details

**Telephone Number:** ✘

**Default Short Code:** ✔ \*31

**Programmable Button Control:** ✔ PickG

**See also:** Call Pickup Any, Call Pickup Extn, Call Pickup Members, Acquire Call, Call Pickup Line, Call Pickup User.

**Release:** 1.0+.

Example

Below is an example of the short code setup.

Short Code: \*31

Feature: CallPickupGroup

### Related links

[Short Code Features](#) on page 827

## Call Pickup Line

Pick up an incoming call which is alerting, parked or held. The pickup uses the Line Appearance ID specified in Telephone Number field of the short code. It cannot be used to pickup conferenced calls. The normal user intrusion features are not applied to this pickup feature.

Details

**Telephone Number:** ✔ Target Line Appearance ID.

**Default Short Code:** ✘

**Programmable Button Control:** ✘

**See also:** Call Pickup Any, Call Pickup Extn, Call Pickup Group, Call Pickup Members, Acquire Call, Call Pickup User.

**Release:** 4.0+ (Added in the Release 4.0 Q2 2007 maintenance release).

Example

This short code is a default within the system configuration. N represents the specific Line Appearance ID.

**Short Code:** \*89\*N#

**Telephone Number:** N

**Feature:** CallPickupLine

## Related links

[Short Code Features](#) on page 827

---

# Call Pickup Members

This feature can be used to pick up a ringing or queuing call at an extension that is a member of the Hunt Group specified. The call picked up does not have to be a hunt group call. The function includes group members even if their membership of the group is currently disabled.

Details

**Telephone Number:** ✓ Group number or "Group name".

**Default Short Code:** ✓ \*53\*N#

**Programmable Button Control:** ✓ PickM

**See also:** Call Pickup Any, Call Pickup Extn, Call Pickup Group, Acquire Call, Call Pickup Line, Call Pickup User.

**Release:** 1.0+.

Example

Below is an example of the short code setup. N represents the extension number of the Hunt Group. For example, if a user dials \*53\*500#, they will pick up the call coming into extension 500 (the hunt group's extension).

Short Code: \*53\*N#

Telephone Number: N

Feature: CallPickupMembers

## Related links

[Short Code Features](#) on page 827

---

# Call Pickup User

Pick up an incoming call which is alerting, parked or held. The pickup uses the user extension number specified in Telephone Number field of the short code. If there are multiple calls, priority is given to picking up alerting, then parked and then held in that order of priority. It cannot be used to pickup conferenced calls. The normal user intrusion features are not applied to this pickup feature.

Details

**Telephone Number:** ✓ Target user extension number.

**Default Short Code:** ✗



**Programmable Button Control:** ✘

**See also:** Call Pickup Any, Call Pickup Extn, Call Pickup Group, Call Pickup Members, Acquire Call, Call Pickup Line.

**Release:** 4.0+.

Example

N represents the specific user.

**Short Code:** \*89\*N#

**Telephone Number:** N

**Feature:** CallPickupUser

**Related links**

[Short Code Features](#) on page 827

---

## Call Queue

Queue the current call to the destination phone, even when the destination phone is busy. This is the same as a transfer except it allows you to transfer to a busy phone.

Details

**Telephone Number:** ✔ Target extension number.

**Default Short Code:** ✔ \*33\*N#

**Programmable Button Control:** ✔ Queue

**Release:** 1.0+.

Example

Below is an example of the short code setup. N represents the extension the caller wishes to queue for. For example, if a user dials \*33\*201# while connected to a caller, this caller will be queued for extension 201.

**Short Code:** \*33\*N#

**Telephone Number:** N

**Feature:** CallQueue

**Related links**

[Short Code Features](#) on page 827

---

## Call Record

This feature allows you to record a conversation. To use this requires Voicemail Pro. Refer to your local regulations in relation to the recording of calls.

This feature uses system conference resources. If insufficient conference resource are available it will not be possible to use this feature.

Release 4.0+: The system provides privacy features that allow users to indicate that a call should not be recorded. See Private Calls.

Details

**Telephone Number:** ✓ Target extension number.

**Default Short Code:** ✗

**Programmable Button Control:** ✓ Recor

**Release:** 1.0+.

Example: Record your own extension's call

To use this short code, the user should place the call on hold and dial \*55. They will automatically be reconnected to the call when recording begins.

**Short Code:** \*55

**Telephone Number:** None

**Feature:** CallRecord

### Related links

[Short Code Features](#) on page 827

---

## Call Steal

This function can be used with or without a specified user target.

If the target has alerting calls, the function will connect to the longest waiting call.

If the target has no alerting calls but does have a connected call, the function will take over the connected call, disconnecting the original user. This usage is subject to the **Can Intrude** setting of the **Call Steal** user and the **Cannot Be Intruded** setting of the target.

If no target is specified, the function attempts to reclaim the user's last ringing or transferred call if it has not been answered or has been answered by voicemail.

Details

**Telephone Number:** ✓ Target extension number or blank for last call transferred.

**Default Short Code:** ✓ \*45\*N# and \*46

**Programmable Button Control:** ✓ Acquire

**Release:** 2.1+

Example: Taking Over a Call

In this example, N represents the extension to be taken over. For example, if a user dials \*45\*201#, they will take over the current call on extension 201.

**Short Code:** \*45\*N#

**Telephone Number:** N

**Feature:** Call Steal

Example: Reclaiming a Call

This short code reclaims the last call from your extension. This function is useful when you want to catch a call you have just missed that has gone off to Voicemail.

**Short Code:** \*46

**Feature:** Call Steal

#### Related links

[Short Code Features](#) on page 827

---

## Call Waiting On

Enables call waiting on the user's extension. When on, if the user receives a second calls when already on a call, they hear a call waiting tone in the speech path.

Call waiting settings are ignored for users with multiple call appearance buttons. In this case the appearance buttons are used to indicate additional calls. Call waiting is automatically applied for users with 'internal twinned' phones.

Details

**Telephone Number:** ✗

**Default Short Code:** ✓ \*15 (not on Server Edition)

**Programmable Button Control:** ✓ CWOOn

**See also:** Call Waiting Off, Call Waiting Suspend.

**Release:** 1.0+.

Example

Below is a sample of the short code setup.

**Short Code:** \*15

**Feature:** CallWaitingOn

### Related links

[Short Code Features](#) on page 827

---

## Call Waiting Off

Disables call waiting on the user's extension. Call waiting may be applied for users with internal twinned phones regardless of their call waiting settings.

Details

**Telephone Number:** ✘

**Default Short Code:** ✔ \*16 (not on Server Edition)

**Programmable Button Control:** ✔ CWOFF

**See also:** Call Waiting On, Call Waiting Suspend.

**Release:** 1.0+.

Example

Below is a sample of the short code setup.

**Short Code:** \*16

**Feature:** Call Waiting Off

### Related links

[Short Code Features](#) on page 827

---

## Call Waiting Suspend

For phones using call waiting, this feature temporarily disables call waiting for the duration of the user's next call.

Details

**Telephone Number:** ✘

**Default Short Code:** ✔ \*70 (A-Law only)

**Programmable Button Control:** ✔ CWSus

**See also:** Call Waiting On, Call Waiting Off.

**Release:** 1.0+.

Example

Below is a sample of the short code setup. This short code is a default within the system configuration.

**Short Code:** \*70

**Feature:** CallWaitingSuspend

#### Related links

[Short Code Features](#) on page 827

---

## Cancel All Forwarding

This feature cancels all forms of forwarding on the user's extension including "Follow Me" and "Do Not Disturb".

Details

**Telephone Number:** ✘

**Default Short Code:** ✔ \*00

**Programmable Button Control:** ✔ FwdOf

**See also:** Forward On Busy On, Forward On Busy Off, Forward On No Answer On, Forward On No Answer Off, Forward Unconditional On, Forward Unconditional Off, Do Not Disturb On, Do Not Disturb Off.

**Release:** 1.0+.

Example

Below is a sample of the short code setup.

**Short Code:** \*00

**Feature:** CancelCallForwarding

#### Related links

[Short Code Features](#) on page 827

---

## Cancel Ring Back When Free

Cancels any existing ring back (also known as callback) set by the user.

Details

**Telephone Number:** ✘

**Default Short Code:** ✘

**Programmable Button Control:** ✓ RBak-

**See also:** Ring Back When Free.

**Release:** 1.0+.

Example: Cancel Ring Back When Free

This example Short Code will cancel Ring Back When Free on the specified extension. N represents the target extension from which you have set a ring back. For example, if Paul has set a ring back on extension 201, he must dial \*84\*201# to cancel that ring back request.

Short Code: \*84\*N#

Telephone Number: N

Feature: CancelRingBackWhenFree

### Related links

[Short Code Features](#) on page 827

---

## Change Login Code

Allows a user to change their login code. The login code must meet the **Login Code Complexity** requirements defined on the Manager **System | Telephony** tab.

### Details

**Telephone Number:** ✓ The user's current and new log in codes separated by a \*, see the examples below.

**Default Short Code:** ✗

**Programmable Button Control:** ✗

Example

The user has a **Login Code** of **1234** and wants to change it to **5678**. To use the short code below, the user must dial **\*60\*1234\*5678#**.

**Short Code:** \*60\*N#

**Telephone Number:** N

**Feature:** Change Login Code.

### Example

For a user with no login code currently set, they can still use the short code to set a login code. For example using the short code created above to set their login code to 1234 they should dial **\*60\*\*1234#**.

### Example

System phone users can also use this short code to change the login code of an other user. For example 403 is configured as a system phone with a login code of **1234**. User 410 has forgotten their login code and needs it changed. User 403 can do this by dialing the following:

**\*60\*410\*1234\*<new code>#**

#### Related links

[Short Code Features](#) on page 827

---

## Clear After Call Work

This feature can be users who have been configured as CCR agents. It allows them to dial a short code to exit the After Call Work (ACW) state as reported by the Customer Call Reporter (CCR) application.

#### Note:

CCR is not supported in IP Office release 9.1 and later.

Details

**Telephone Number:** ✘

**Default Short Code:** ✘

**Programmable Button Control:** ✔ ACWrk

**See also:** Start After Call Work.

**Release:** 4.2 4Q 2008 Maintenance release+.

#### Related links

[Short Code Features](#) on page 827

---

## Clear Call

This feature can be used to end the current call.

Details

**Telephone Number:** ✘

**Default Short Code:** ✔ \*52

**Programmable Button Control:** ✔ Clear

**Release:** 1.0+.

Example

Below is a sample of the short code setup. This example could be used in a situation where you are doing a supervised transfer and the party to be transferred to does not want to take the call. In this scenario, you can put the call on hold and dial \*52. This will clear the last connected call (for example the party who has just refused the transfer), and retrieve the original call or dial tone.

**Short Code:** \*52

**Feature:** Deny/ClearCall

#### Related links

[Short Code Features](#) on page 827

---

## Clear CW

This feature is most commonly used to end the user's current call and answer the waiting call.

#### **Note:**

Call waiting settings are ignored for users with multiple call appearance buttons.

#### **Details**

**Telephone Number:** ✘

**Default Short Code:** ✔ \*26 (A-Law only) (not on Server Edition)

**Programmable Button Control:** ✔ ClrCW

**Release:** 1.0+.

#### **Example**

Below is a sample of the short code setup.

**Short Code:** \*26

**Feature:** ClearCW

#### Related links

[Short Code Features](#) on page 827

---

## Clear Hunt Group Night Service

This feature changes the specified hunt group from Night Service mode to In Service mode.

Setting and clearing hunt group night service can be done using either manual controls or using a system time profile. The use of both methods to control the night service status of a particular hunt group is not supported.



This function is currently not supported between systems in a multi-site network. It can only be used by a user currently logged onto the same system as hosting the hunt group.

#### Details

**Telephone Number:** ✓ Hunt group extension number. If left blank, the short code will affect all hunt groups of which the user is a member.

The **Set Hunt Group Night Service** and **Clear Hunt Group Night Service** short code and button features can be used to switch an SSL VPN service off or on respectively. The service is indicated by setting the service name as the telephone number or action data. Do not use quotation marks.

**Default Short Code:** ✓ \*21\*N#

**Programmable Button Control:** ✓ HGNS-

**See also:** Clear Hunt Group Out Of Service, Set Hunt Group Night Service, Set Hunt Group Out Of Service.

**Release:** 1.0+.

#### Example

Below is a sample of the short code setup. N represents the telephone number of the hunt group to be taken out of "Night Service" mode and placed into "In Service" mode. For example, when \*21\*201# is dialed, the hunt group associated with extension 201 will be taken out of "Night Service" mode.

**Short Code:** \*21\*N#

**Telephone Number:** N

**Feature:** ClearHuntGroupNightService

#### Related links

[Short Code Features](#) on page 827

---

## Clear Hunt Group Out Of Service

This feature changes the specified hunt group from Out of Service mode to In Service mode. This will not override a hunt group in night service due to a time profile.

#### Details

**Telephone Number:** ✓ Hunt group extension number. If left blank, the short code will affect all hunt groups of which the user is a member.

**Default Short Code:** ✗

**Programmable Button Control:** ✓ HGOS-

**See also:** Clear Hunt Group Night Service, Set Hunt Group Night Service, Set Hunt Group Out Of Service.

**Release:** 1.0+.

Example

Below is a sample short code using the Clear Hunt Group Out Of Service feature. N represents the telephone number of the hunt group to be taken out of "Out of Service" mode. For example, when \*55\*201# is dialed, the hunt group associated with extension 201 will be placed into "In Service" mode.

**Short Code:** \*55\*N#

**Telephone Number:** N

**Feature:** ClearHuntGroupOutOfService

#### Related links

[Short Code Features](#) on page 827

---

## Clear Quota

This feature refreshes the time quota for all services or a specific service.

Details

**Telephone Number:** ✓ "Service name" or "" (all services).

**Default Short Code:** ✗

**Programmable Button Control:** ✓ Quota

**Release:** 1.0+.

#### Related links

[Short Code Features](#) on page 827

---

## Coaching Intrusion

This feature allows the you to intrude on another user's call and to talk to them without being heard by the other call parties to which they can still talk. For example: User A is on a call with user B. When user C intrudes on user A, they can hear users A and B but can only be heard by user A.

The ability to intrude and be intruded is controlled by two configuration settings, the Can Intrude (User | Telephony | Supervisor Settings) setting of the user intruding and the Cannot Be Intruded (User | Telephony | Supervisor Settings) setting of target being intruded on. The setting of any other internal party is ignored. By default, no users can intrude and all users are set to cannot be intruded.

**⚠ Warning:**

The use of features to listen to a call without the other call parties being aware of that monitoring may be subject to local laws and regulations. Before enabling the feature you must ensure that you have complied with all applicable local laws and regulations. Failure to do so may result in severe penalties.

The system support a range of other call intrusion methods in addition to this feature.

Details

**Telephone Number:** ✓ Target extension number.

**Default Short Code:** ✗

**Programmable Button Control:** ✓ Coach.

**See also:** Call Intrude, Call Listen, Dial Inclusion, Whisper Page.

**Release:**9.0+

**Related links**

[Short Code Features](#) on page 827

---

## Conference Add

Conference add controls can be used to place the user, their current call and any calls they have on hold into a conference. When used to start a new conference, the system automatically assigns a conference ID to the call. This is termed ad-hoc (impromptu) conferencing.

If the call on hold is an existing conference, the user and any current call are added to that conference. This can be used to add additional calls to an ad-hoc conference or to a meet-me conference. Conference add can be used to connect two parties together. After creating the conference, the user can drop from the conference and the two incoming calls remain connected.

For further details refer to the Conferencing section.

Details

**Telephone Number:** ✗

**Default Short Code:** ✓ \*47

**Programmable Button Control:** ✓ Conf+

**See also:** Conference Meet Me.

**Release:** 1.0+.

Example

Below is a sample of the short code setup.

**Short Code:** \*47

**Feature:** ConferenceAdd

**Related links**

[Short Code Features](#) on page 827

---

## Conference Meet Me

Conference meet-me refers to features that allow a user or caller to join a specific conference by using the conference's ID number (either pre-set in the control or entered at the time of joining the conference).

IP500 and IP500 V2 systems require a **Preferred Edition** license.

**\* Note:**

Conference Meet Me features can create conferences that include only one or two parties. These are still conferences that are using resources from the host system's conference capacity.

### Conference ID Numbers

By default, ad hoc conferences are assigned numbers starting from 100 for the first conference in progress. Therefore, for conference Meet Me features specify a number away from this range ensure that the conference joined is not an ad hoc conference started by other users. It is no longer possible to join a conference using conference Meet Me features when the conference ID is in use by an ad-hoc conference.

**User Personal Conference Number** Each user's own extension number is treated as their own personal conference number. Only that user is able to start a conference using that number as the conference ID. Any one else attempting to start a conference with that number will find themselves in a conference but on hold until the owner also joins. Personal conferences are always hosted on the owner's system.

**\* Note:**

When a user calls from their mobile twinned number, the personal conference feature will only work if they access the conference using an FNE 18 service.

### Multi-Site Network Conferencing

Meet Me conference IDs are now shared across a multi-site network. For example, if a conference with the ID 500 is started on one system, anyone else joining conference 500 on any system will join the same conference. Each conference still uses the conference resources of the system on which it was started and is limited by the available conference capacity of that system.

Previously separate conferences, each with the same conference ID, could be started on each system in a multi-site network.

### Other Features

**Transfer to a Conference Button** A currently connected caller can be transferred into the conference by pressing **TRANSFER**, then the Conference Meet Me button and **TRANSFER** again to complete the transfer. This allows the user to place callers into the conference specified by the button without being part of the conference call themselves. This option is only supported on Avaya phones with a fixed **TRANSFER** button.

**Conference Button Status Indication** When the conference is active, any buttons associated with the conference ID indicate the active state.

For further details refer to the Conferencing section.

Details

### Details

- **Telephone Number:** ✓ Conference number. This can be an alphanumeric value up to 15 characters.
  - The number can be prefixed with **H(x)** where **x** is the number of the music-on-hold source that should be played to the first caller to enter the conference.
- **Default Short Code:** ✗ / ✓ \*66\*N# on Server Edition systems.
- **Programmable Button Control:** ✓ CnfMM
- **See also:** Conference Add.
- **Release:** 1.0+.

### Related links

[Short Code Features](#) on page 827

## CW

Pick up the waiting call. This feature provides same functionality as pressing the **Recall** or **Hold** key on the phone. Unlike the Clear CW feature, this feature does not disconnect you from the existing call when the second call is picked up.

Details

**Telephone Number:** ✗

**Default Short Code:** ✗

**Programmable Button Control:** ✗

**Release:** 1.0+.

### Related links

[Short Code Features](#) on page 827

---

## Dial

This short code feature allows users to dial the number specified to an outside line.

Details

**Telephone Number:** ✓ Telephone number.

**Default Short Code:** ✓ Various depending on locale and system type.

**Programmable Button Control:** ✓ Dial

**See also:** Dial Direct, Dial Emergency, Dial Extn, Dial Inclusion, Dial Paging.

**Release:** 1.0+.

Example: Creating a Speed Dial

In this example, users entering 401 on their telephone key pad will dial the New Jersey Office on 212 555 0000.

**Short Code:** 401

**Telephone Number:** 2125550000

Example: Replace Outgoing Caller ID

This short code is useful in a "call center" environment where you do not want customers to have access to the number of your direct line; you want the general office number displayed. The sample short code below will force the outgoing caller ID to display 123.

 **Note:**

The usability of this feature is dependent upon your local service provider.

**Short Code:** ?

**Telephone Number:** .s123

Example: External Dialing Prefix

The short code is for dialing a prefix for an outside line N represents the external number you want to call.

**Short Code:** 9N

**Telephone Number:** N

Example: Blocking Caller ID

This is for blocking Caller ID for external calls. This feature can be applied to specific external numbers or to all out going calls. In most situations, the company will choose to block the caller ID for all external calls or leave it available for all external calls.

**Short Code:** 9N

**Telephone Number:** NW

Example: Maximum Call Length

The character t can be used in dialing short codes to set the maximum allowed duration of a call. For example, the following short code will dial a number but then disconnect the call after 20 minutes (plus or minus a minute).

**Short Code:** 9N

**Telephone Number:** Nt(20)

#### Related links

[Short Code Features](#) on page 827

---

## Dial 3K1

Sets the ISDN bearer capabilities to 3.1Khz audio call.

Details

**Telephone Number:** ✓ Telephone number.

**Default Short Code:** ✗

**Programmable Button Control:** ✓ D3K1

**Release:** 1.0+.

#### Related links

[Short Code Features](#) on page 827

---

## Dial 56K

Sets the ISDN bearer capabilities to 56Kbps data call.

Details

**Telephone Number:** ✓ Telephone number.

**Default Short Code:** ✗

**Programmable Button Control:** ✓ D56K

**Release:** 1.0+.

#### Related links

[Short Code Features](#) on page 827

---

## Dial 64K

Sets the ISDN bearer capabilities to 64Kbps data call.

Details

**Telephone Number:** ✓ Telephone number.

**Default Short Code:** ✗

**Programmable Button Control:** ✓ D64K

**Release:** 1.0+.

### Related links

[Short Code Features](#) on page 827

---

## Dial CW

Call the specified extension number and force call waiting indication on if the extension is already on a call.

If the user has call appearance buttons programmed, call waiting will not get activated. The next incoming call will appear on an available call appearance button. When there are no available call appearance buttons, the next incoming call will receive busy tone.

Details

**Telephone Number:** ✓ Extension number.

**Default Short Code:** ✗

**Programmable Button Control:** ✓ DCW

**Release:** 1.0+.

Example

N represents the extension number to be dialed. For example, a user dialing \*97\*201# will force call waiting indication on at extension 201 if extension 201 is already on a call.

**Short Code:** \*97\*N#

**Telephone Number:** N

**Feature:** DialCW

### Related links

[Short Code Features](#) on page 827



---

## Dial Direct

Automatic intercom functions allow you to call an extension and have the call automatically answered on speaker phone after 3 beeps. The extension called must support a handsfree speaker. If the extension does not have a handsfree microphone then the user must use the handset if they want to talk. If the extension is not free when called, the call is presented as a normal call on a call appearance button if available.

Details

**Telephone Number:** ✓ Extension number

**Default Short Code:** ✗

**Programmable Button Control:** ✓ Direct

**See also:** Dial Paging.

**Release:** 1.0+.

Example

This allows the extension specified to be automatically answered. N represents the extension that will be forced to automatically answer. For example, when a user dials \*83\*201#, extension 201 will be forced to automatically answer the call.

**Short Code:** \*83\*N#

**Telephone Number:** N

**Feature:** DialDirect

### Related links

[Short Code Features](#) on page 827

---

## Dial Direct Hot Line

When the line appearance button is mapped to a short code using the DialDirectHotLine short code feature, no secondary dial tone is generated and the number is dialed directly. This feature should not be confused with the hot line feature enabled using ?D short codes.

Details

**Telephone Number:** ✓

**Default Short Code:** ✗

**Programmable Button Control:** ✗

**Release:** 3.0 to 4.0, 8.0+

Example

Below is a sample short code using the DialDirectHotLine feature. The short code \*83\* should then be set as the prefix for the particular line required.

**Short Code:** \*83\*

**Telephone Number:** .

**Feature:** DialDirectHotLine

#### Related links

[Short Code Features](#) on page 827

---

## Dial Emergency

Dials the number specified regardless of any call barring applicable to the user.

On all systems, regardless of locale; system and or ARS short codes using the Dial Emergency feature should be created for any required emergency service numbers. Those short codes should be usable by all users from all extensions. Those short codes should route the calls to suitable lines. If the system uses prefixes for external dialing, the dialing of emergency numbers with and without the prefix should be allowed.

The blocking of emergency calls or the rerouting of emergency calls to a intermediate destination other than the central office may be against local and nation laws.

- Details of calls made using this function can be viewed using an **Emergency View** button. See [Emergency View](#) on page 1006.

Details

**Telephone Number:** ✓ Telephone number.

**Default Short Code:** ✗

**Programmable Button Control:** ✓ Emrgy

**Release:** 1.0+.

#### Related links

[Short Code Features](#) on page 827

---

## Dial Extn

This feature can be used to dial an internal extension number (user or hunt group).

Details

**Telephone Number:** ✓ Extension number.

**p( x )** can be added as a suffix to the **Telephone Number** to change the priority of a call. Allowable values for **x** are **1**, **2** or **3** for low, medium or high priority respectively. For example **Np(1)**.

**Default Short Code:** ✘

**Programmable Button Control:** ✘

**See also:** Dial Direct, Dial Paging, DialPhysicalExtensionByNumber, DialPhysicalNumberByID.

**Release:** 1.0+.

Example: Dial on Pick up

The following user short code dials the extension specified the moment the user's handset is picked up.

**Short Code:** ?D

**Telephone Number:** 201

**Line Group ID:** 0

**Feature:** Dial Extn

#### Related links

[Short Code Features](#) on page 827

## Dial Fax

This feature is used to route fax calls via Fax Relay.

Details

**Telephone Number:** ✔ Fax destination number.

**Default Short Code:** ✘

**Programmable Button Control:** ✘

**Release:** 5.0+.

Example

In this example, the line group ID matches the URI configured on a SIP line that has been configured for Fax Relay.

**Short Code:** 6N

**Telephone Number:** N"@192.16.42.5"

**Line Group ID:** 17

**Feature:** Dial Fax

## Related links

[Short Code Features](#) on page 827

---

# Dial Inclusion

This feature allows you to intrude on another user's call to talk to them. Their current call is put on hold while you talk and automatically reconnected when you end the intrusion. The intruder and the target extension can then talk but cannot be heard by the other party. This can include intruding into a conference call, where the conference will continue without the intrusion target.

During the intrusion all parties hear a repeated intrusion tone. When the intruder hangs-up the original call parties are reconnected. Attempting to hold a dial inclusion call simply ends the intrusion. The inclusion cannot be parked.

The ability to intrude and be intruded is controlled by two configuration settings, the Can Intrude (User | Telephony | Supervisor Settings) setting of the user intruding and the Cannot Be Intruded (User | Telephony | Supervisor Settings) setting of target being intruded on. The setting of any other internal party is ignored. By default, no users can intrude and all users are set to cannot be intruded.

The system support a range of other call intrusion methods in addition to this feature.

Details

**Telephone Number:** ✓ Target extension number.

**Default Short Code:** ✗

**Programmable Button Control:** ✓ Inclu.

**See also:** Call Intrude, Call Listen, Coaching Intrusion, Whisper Page.

**Release:** 1.4+.

Example

N represents the extension to be intruded upon. For example, if a user dials \*97\*201# while extension 201 is on a call, then the user is intruding into extn. 201's current call.

**Short Code:** \*97\*N#

**Telephone Number:** N

**Feature:** DialInclusion

## Related links

[Short Code Features](#) on page 827

---

## Dial Paging

This feature makes a page call to an extension or group. The target extension or group members must support page calls (that is be able to auto-answer calls).

Details

**Telephone Number:** ✓ Extension or group number.

**Default Short Code:** ✗

**Programmable Button Control:** ✓ Page

**See also:** Dial Direct.

**Release:** 1.0+.

When paging, always use only one codec (the preferred). It is the system administrator's responsibility to ensure all the phones in the paging group support the codec.

### Related links

[Short Code Features](#) on page 827

---

## Dial Physical Extension by Number

Dial a specified extension number regardless of the current user logged in at that extension and any forwarding, follow me or do not disturb settings applied by the current extension user. Note that the extension number used is the Base Extension number set against the extension configuration settings.

Details

**Telephone Number:** ✓ Base Extension number.

**Default Short Code:** ✓ \*70\*N# (U-Law only) (not on Server Edition)

**Programmable Button Control:** ✓ PhyEx

**See also:** Dial Physical Extension By Id, Priority Call.

**Release:** 1.4+.

Example

The example below allows the extension with the base extension number 201 to be called regardless of the extension number of the user currently logged in at that extension.

**Short Code:** \*97

**Telephone Number:** 201

**Feature:** DialPhysicalExtnByNumber

## Related links

[Short Code Features](#) on page 827

---

# Dial Physical Extension By ID

Dial a specific extension using its system ID. This may be necessary in hot desking environments where some extensions have been created with no default extension number. Without an extension number, a call can not be made to that extension unless a short code is created.

Details

**Telephone Number:** ✓ Extension ID

**Default Short Code:** ✓ \*71\*N# (U-Law only)

**Programmable Button Control:** ✓ DialP

**See also:** DialPhysicalExtensionByNumber, Priority Call.

**Release:** 1.4+.

Example

In the above example, if the telephone at extension ID 16 is not associated with an extension number, a user can dial \*97 to connect to that phone. This may be useful in hot desking environments where some extensions may not have a dedicated base extension number.

**Short Code:** \*97

**Telephone Number:** 16

**Feature:** DialPhysicalNumberByID

## Related links

[Short Code Features](#) on page 827

---

# Dial Speech

This feature allows a short code to be created to force the outgoing call to use the Speech bearer capability.

Details

**Telephone Number:** ✓ Telephone number.

**Default Short Code:** ✗

**Programmable Button Control:** ✓ DSpch

**Release:** 1.0+.

**Related links**

[Short Code Features](#) on page 827

---

## Dial V110

Sets the ISDN bearer capabilities to V110. The call is presented to local exchange as a "Data Call".

Details

**Telephone Number:** ✓ Telephone number.

**Default Short Code:** ✗

**Programmable Button Control:** ✓ DV110

**Release:** 1.0+.

**Related links**

[Short Code Features](#) on page 827

---

## Dial V120

Sets the ISDN bear capabilities using V.120.

Details

**Telephone Number:** ✓ Telephone number.

**Default Short Code:** ✗

**Programmable Button Control:** ✓ DV120

**Release:** 1.0+.

**Related links**

[Short Code Features](#) on page 827

---

## Dial Video

The call is presented to the local exchange as a "Video Call".

Details

**Telephone Number:** ✓ Telephone number.

**Default Short Code:** ✘

**Programmable Button Control:** ✔ Dvide

**Release:** 1.0+.

#### Related links

[Short Code Features](#) on page 827

---

## Disable ARS Form

This feature can be used to put an ARS form out of service. It can be used with ARS forms for which an Out of Service Route has been configured in Manager. The short code feature Enable ARS Form can be used to return an ARS form to in service.

Details

**Telephone Number:** ARS form number.

**Default Short Code:** ✘

**Programmable Button Control:** ✘

**See also:** Enable ARS Form

**Release:** 4.0+.

#### Related links

[Short Code Features](#) on page 827

---

## Disable Internal Forwards

This feature turns off the forwarding of internal calls for the user. It applies to Forward Unconditional, Forward on Busy and Forward on No Answer.

Details

**Telephone Number:** ✘

**Default Short Code:** ✘

**Programmable Button Control:** ✘

**See also:** Disable Internal Forwards Unconditional, Disable Internal Forwards Busy or No Answer, Cancel All Forwarding, Enable Internal Forwards, Enable Internal Forwards Unconditional, Enable Internal Forwards Busy or No Answer.

**Release:** 3.2+.



**Related links**

[Short Code Features](#) on page 827

---

## Disable Internal Forward Unconditional

This feature turns off the forwarding of internal calls for the user. It applies to Forward Unconditional only.

Details

**Telephone Number:** ✘

**Default Short Code:** ✘

**Programmable Button Control:** ✘

**See also:** Disable Internal Forwards, Disable Internal Forwards Busy or No Answer, Cancel All Forwarding, Enable Internal Forwards, Enable Internal Forwards Unconditional, Enable Internal Forwards Busy or No Answer.

**Release:** 3.2+.

**Related links**

[Short Code Features](#) on page 827

---

## Disable Internal Forward Busy or No Answer

This feature turns off the forwarding of internal calls for the user. It applies to Forward on Busy and Forward on No Answer.

**Telephone Number:** No

**Default Short Code:** No

**Programmable Button Control:** No

**See also:** Disable Internal Forwards, Disable Internal Forwards Unconditional, Cancel All Forwarding, Enable Internal Forwards, Enable Internal Forwards Unconditional, Enable Internal Forwards Busy or No Answer.

**Related links**

[Short Code Features](#) on page 827

---

## Display Msg

Allows the sending of text messages to digital phones on the local system.

**Telephone Number:** The telephone number takes the format N";T" where:

- **N** is the target extension.
- **T** is the text message. Note that the ";" before the text and the " after the text are required.

**Default Short Code:** No

**Programmable Button Control:** Displ

### Example

Below is a sample of the short code setup. When used, the target extension will hear a single ring and then see the message. If the target extension is on a call then may need to scroll the display to a free call appearance in order to see the text message.

**Short Code:** \*78\*N#

**Feature:** Display Msg

**Telephone Number:** N";Visitor in Reception"

### SIP Extension Message Waiting Indicator

You can use the Display Msg short code to turn an extension's message waiting indicator (MWI) on or off.

**Telephone Number:** The telephone number takes the format N";T" where:

- **N** is the target extension.
- **T** is the text message. Note that the ";" before the text and the " after the text are required.

To turn MWI on, the telephone number must be **N";Mailbox Msgs=1"**.

To turn MWI off, the telephone number must be **N";Mailbox Msgs=0"**.

**Default Short Code:** No

### Example

Below is a sample of the short code setup to turn MWI on. When used, the target extension will receive a message directing it to turn the MWI on.

**Short Code:** \*99\*N#

**Feature:** Display Msg

**Telephone Number:** N";Mailbox Msgs=1"

### Example

Below is a sample of the short code setup to turn MWI off. When used, the target extension will receive a message directing it to turn the MWI off.

**Short Code:** \*98\*N#

**Feature:** Display Msg

**Telephone Number:** N";Mailbox Msgs=0"

#### Related links

[Short Code Features](#) on page 827

---

## Do Not Disturb Exception Add

This feature adds a number to the user's "Do Not Disturb Exception Numbers List". This can be an internal extension number or external ICLID. Calls from that number, except hunt group calls, will ignore the user's Do Not Disturb setting. For further details see Do Not Disturb (DND).

**Telephone Number:** Telephone number or ICLID. Up to 31 characters. For ICLID numbers any prefix added by the system must also be included.

**Default Short Code:** \*10\*N#

**Programmable Button Control:** DNDX+

**See also:** Do Not Disturb Exception Delete, Do Not Disturb On, Do Not Disturb Off.

#### Example

N represents the number to be added to the user's "Do Not Disturb Exception List". For example, when a user has DND turned on and dials \*10\*4085551234#, incoming calls from telephone number (408) 555-1234. All other calls, except those numbers on the exception list hear busy tones or are redirected to voicemail if available.

**Short Code:** \*10\*N#

**Telephone Number:** N

**Feature:** DoNotDisturbExceptionAdd

#### Example

In this example, the last number received by the user is added to their exception list.

**Short Code:** \*89

**Telephone Number:** L

**Feature:** DoNotDisturbExceptionAdd

#### Related links

[Short Code Features](#) on page 827

---

## Do Not Disturb Exception Delete

This feature removes a number from the user's "Do Not Disturb Exception List". For further details see Do Not Disturb (DND).

#### Details

**Telephone Number:** ✓ Telephone number or ICLID.

**Default Short Code:** ✓ \*11\*N#

**Programmable Button Control:** ✓ DNDX-

**See also:** Do Not Disturb Exception Add, Do Not Disturb On, Do Not Disturb Off.

**Release:** 1.0+.

#### Example

N represents the number to be deleted from the user's "Do Not Disturb Exception List". For example, when a user has DND turned on and the telephone number (408) 555-1234 in their "Do Not Disturb Exception List", dialing \*10\*4085551234# will remove this phone number from the list. Incoming calls from (408) 555-1234 will no longer be allowed through; instead they will hear busy tone or be redirected to voicemail if available.

**Short Code:** \*11\*N#

**Telephone Number:** N

**Feature:** DoNotDisturbExceptionDel

#### Related links

[Short Code Features](#) on page 827

---

## Do Not Disturb On

This feature puts the user into 'Do Not Disturb' mode. When on, all calls, except those from numbers in the user's exception list hear busy tones or are redirected to voicemail if available. For further details see Do Not Disturb (DND).

#### \* Note:

CCR is not supported in IP Office release 9.1 and later.

#### Details

**Telephone Number:** ✗

**Default Short Code:** ✓ \*08

**Programmable Button Control:** ✓ DNDOOn

**See also:** Do Not Disturb Off, Do Not Disturb Exception Add, Do Not Disturb Exception Delete.

**Release:** 1.0+.

#### Example

Below is a sample of the short code setup.

**Short Code:** \*08

**Feature:** DoNotDisturbOn

#### Related links

[Short Code Features](#) on page 827

---

## Do Not Disturb Off

Cancels the user's 'do not disturb' mode if set. For further details see Do Not Disturb (DND).

Details

**Telephone Number:** ✘

**Default Short Code:** ✔ \*09

**Programmable Button Control:** ✔ DNDOF

**See also:** Do Not Disturb On, Do Not Disturb Exception Add, Do Not Disturb Exception Delete.

**Release:** 1.0+.

Example

This short code is a default within the system configuration. Below is a sample of the short code setup.

**Short Code:** \*09

**Feature:** DoNotDisturbOff

#### Related links

[Short Code Features](#) on page 827

---

## Enable ARS Form

This feature can be used to put an ARS form in service. It can be used with ARS forms that have been put out of service through Manager or the use of a Disable ARS Form short code.

Details

**Telephone Number:** ARS form number.

**Default Short Code:** ✘

**Programmable Button Control:** ✘

**Release:** 4.0+

### Related links

[Short Code Features](#) on page 827

---

## Enable Internal Forwards

This feature turns on the forwarding of internal calls for the user. It applies to Forward Unconditional, Forward on Busy and Forward on No Answer.

Details

**Telephone Number:** ✘

**Default Short Code:** ✘

**Programmable Button Control:** ✘

**See also:** Disable Internal Forwards, Disable Internal Forwards Unconditional, Disable Internal Forwards Busy or No Answer, Cancel All Forwarding, Enable Internal Forwards Unconditional, Enable Internal Forwards Busy or No Answer.

**Release:** 3.2+.

### Related links

[Short Code Features](#) on page 827

---

## Enable Internal Forward Unconditional

This feature turns on the forwarding of internal calls for the user. It applies to Forward Unconditional only.

Details

**Telephone Number:** ✘

**Default Short Code:** ✘

**Programmable Button Control:** ✘

**See also:** Disable Internal Forwards, Disable Internal Forwards Unconditional, Disable Internal Forwards Busy or No Answer, Cancel All Forwarding, Enable Internal Forwards, Enable Internal Forwards Busy or No Answer.

**Release:** 3.2+.

### Related links

[Short Code Features](#) on page 827

---

## Enable Internal Forward Busy or No Answer

This feature turns on the forwarding of internal calls for the user. It applies to Forward on Busy and Forward on No Answer.

Details

**Telephone Number:** ✘

**Default Short Code:** ✘

**Programmable Button Control:** ✘

**See also:** Disable Internal Forwards, Disable Internal Forwards Unconditional, Disable Internal Forwards Busy or No Answer, Cancel All Forwarding, Enable Internal Forwards, Enable Internal Forwards Unconditional.

**Release:** 3.2+.

### Related links

[Short Code Features](#) on page 827

---

## Extn Login

**Extn Login** allows a user who has been configured with a Login Code (User | Telephony | Supervisor Settings) to take over ownership of any extension. That user's extension number becomes the extension number of the extension while they are logged. This is also known as 'hot desking'.

Hot desking is not supported for H175, E129 and J129 telephones.

When used, the user will be prompted to enter their extension number and then their log in code. Login codes of up to 15 digits are supported with **Extn Login** buttons. Login codes of up to 31 digits are supported with **Extn Login** short codes.

When a user logs in, as many of their user settings as possible are applied to the extension. The range of settings applied depends on the phone type and on the system configuration.

By default, on 1400 Series, 1600 Series, 9500 Series and 9600 Series phones, the user's call log and personal directory are accessible while they are logged in. This also applied to M-Series and T-Series telephones.

On other types of phone, those items such as call logs and speed dials are typically stored locally by the phone and will not change when users log in and log out.

If the user logging in was already logged in or associated with another phone, they will be automatically logged out that phone.

Details

**Telephone Number:** ✓ Extension Number\*Login Code. If just a single number is dialed containing no \* separator, the system assumes that the extension number to use is the physical extension's Base Extension number and that the number dialed is the log in code.

**Default Short Code:** ✓ \*35\*N#

**Programmable Button Control:** ✓ Login

**See also:** Extn Logout.

**Release:** 1.0+.

Example: Individual Hot Desking

Based on the above sample short code, Paul (extension 204) can go to another phone (even if it is already logged in by another user) and log in as extension 204 by simply dialing 299. Once Paul has logged into this phone, extension 204 is logged out at Paul's original phone. For Paul to make use of this short code, his log in code must match that configured in the above short code. When Paul logs out of the phone he has "borrowed", his original extension will automatically be logged back in.

**Short Code:** 299

**Telephone Number:** 204\*1234

**Feature:** Extnlogin

Example: Log In

The default short code for logging into a phone is configured as shown below. N represents the users extension number followed by a \* and then their log in code, for example \*35\*401\*123#.

**Short Code:** \*35\*N#

**Telephone:** N

**Feature:** ExtnLogin

#### Related links

[Short Code Features](#) on page 827

---

## Extn Logout

This feature logs the user off the phone at which they are logged in. This feature cannot be used by a user who does not have a log in code or by the default associated user of an extension unless they are set to forced log in.

Details

**Telephone Number:** ✗

**Default Short Code:** ✓ \*36



**Programmable Button Control:** ✓ Logof

**See also:** Extn Login.

**Release:** 1.0+.

Example

Below is a sample short code using the Extn Logout feature. This short code is a default within the system configuration.

**Short Code:** \*36

**Feature:** ExtnLogout

#### Related links

[Short Code Features](#) on page 827

---

## Flash Hook

This feature sends a hook flash signal to the currently connected line if it is an analog line.

Only supported for analog lines on the same system as the short code.

See [Centrex Transfer](#) on page 737.

Details

**Telephone Number:** Optional The telephone number field can be used to set the transfer destination number for a Centrex Transfer. In this case the use of the short code Forced Account Code and Forced Authorization Code are not supported and the Line Group Id must match the outgoing line to the Centrex service provider.

**Default Short Code:** ✗

**Programmable Button Control:** ✓ Flash

**Release:** 1.4+.

Example

Below is a sample short code using the Flash Hook feature.

**Short Code:** \*96

**Feature:** FlashHook

#### Related links

[Short Code Features](#) on page 827

---

## FNE Service

This short code feature is used for Mobile Call Control and one-X Mobile Client support.

Details

**Telephone Number:** ✓ This number sets the required FNE function.

**Default Short Code:** ✗

**Programmable Button Control:** ✗

**Release:** 4.2+.

### Related links

[Short Code Features](#) on page 827

---

## Follow Me Here

Causes calls to the extension number specified to be redirected to the extension initiating the 'Follow Me Here'. If the redirected call receives a busy tone or is not answered, then the call behaves as though the User's extension had failed to answer. For further details see Follow Me.

Details

**Telephone Number:** ✓ Extension to redirect to the dialing extension.

**Default Short Code:** ✓ \*12\*N#

**Programmable Button Control:** ✓ Here+

**See also:** Follow Me Here Cancel, Follow Me To.

**Release:** 1.0+.

Example

This feature is used at the Follow Me destination. N represents the extension number of the user wanting their calls redirected to that destination. For example, User A's extension is 224. However they are working at extension 201 and want their calls redirected there. If the following short code is available, they can do this by dialing \*12\*224# at extension 201.

**Short Code:** \*12\*N#

**Telephone Number:** N

**Feature:** FollowMeHere

### Related links

[Short Code Features](#) on page 827

---

## Follow Me Here Cancel

Cancels any Follow Me set on the specified extension. This action can only be performed at the extension to which the Follow Me Here is targeted. For further details see Follow Me.

Details

**Telephone Number:** ✓ Extension being redirected to the dialing extension.

**Default Short Code:** ✓ \*13\*N#

**Programmable Button Control:** ✓ Here-

**See also:** Follow Me Here, Follow Me To.

**Release:** 1.0+.

Example

This feature is used at the Follow Me destination. N represents the extension number of the user whose calls are being redirected to that destination. For example, User A's extension is 224. However they are working at extension 201 and so have set a Follow Me on their own extension to redirect their calls to 201. If the following short code is available, they can cancel the Follow Me by dialing \*13\*224# at extension 201.

**Short Code:** \*13\*N#

**Telephone Number:** N

**Feature:** FollowMeHereCancel

### Related links

[Short Code Features](#) on page 827

---

## Follow Me To

Causes calls to the extension to be redirected to the Follow Me destination extension specified. For further details see Follow Me.

Details

**Telephone Number:** ✓ Target extension number or blank (cancel Follow Me To)

**Default Short Code:** ✓ \*14\*N#

**Programmable Button Control:** ✓ FolTo

**See also:** Follow Me Here, Follow Me Here Cancel.

**Release:** 1.0+.

Example

This feature is used at the extension that wants to be redirected. N represents the extension number to which the user wants their calls redirected. For example, User A's extension is 224. However they are working at extension 201 and want their calls redirected there. If the following short code is available, they can do this by dialing \*14\*201# at extension 224.

**Short Code:** \*14\*N#

**Telephone Number:** N

**Feature:** FollowMeTo

#### Related links

[Short Code Features](#) on page 827

---

## Forward Hunt Group Calls On

Forward the user's hunt group calls (internal and external) to their forward number when the user has Forward Unconditional active. For further details see Forward Unconditional.

This option is only applied for calls to **Sequential** and **Rotary** type hunt groups. Calls from other types of hunt group types are not presented to the user when they have Forward Unconditional active. Note also that hunt group calls cannot be forwarded to another hunt group.

Details

**Telephone Number:** ✘

**Default Short Code:** ✔ \*50

**Programmable Button Control:** ✔ FwdH+

**See also:** Forward Hunt Group Calls Off, Forward Unconditional On, Forward Unconditional Off.

**Release:** 1.0+.

Example

This short code is useful if the hunt group member temporarily uses another workstation and so does not require a permanent extension change.

**Short Code:** \*50

**Feature:** ForwardHuntgroupCallsOn

#### Related links

[Short Code Features](#) on page 827

---

## Forward Hunt Group Calls Off

This feature cancels the forwarding of the user's hunt group calls. For further details see Forward Unconditional.

Details

**Telephone Number:** ✘

**Default Short Code:** ✔ \*51

**Programmable Button Control:** ✔ FwdH-

**See also:** Forward Hunt Group Calls On, Forward Unconditional On, Forward Unconditional Off.

**Release:** 1.0+.

Example

Below is a sample of the short code setup.

**Short Code:** \*51

**Feature:** ForwardHuntgroupCallsOff

### Related links

[Short Code Features](#) on page 827

---

## Forward Number

Sets the number to which the user's calls are redirected. This can be an internal or external number. The number is still subject to the user's call barring settings. For further details see Forward Unconditional.

This feature does not activate forwarding; it only sets the number for the forwarding destination.

This number is used for all forward types; Forward Unconditional, Forward on Busy and Forward on No Answer, unless the user has a separate Forward on Busy Number set for forward on busy and forward on no answer functions.

Details

**Telephone Number:** ✔ Telephone number.

**Default Short Code:** ✔ \*07\*N#

**Programmable Button Control:** ✔ FwdNo

**See also:** Forward On Busy Number.

**Release:** 1.0+.

Example

N represents the forward destination. For example, if extension 224 wants to set the forwarding number to extension 201, the user can dial \*07\*201#.

**Short Code:** \*07N\*#

**Telephone Number:** N

**Feature:** ForwardNumber

#### Related links

[Short Code Features](#) on page 827

---

## Forward On Busy Number

Sets the number to which the user's calls are forwarded when Forward on Busy or Forward on No Answer are on. If no Forward on Busy Number is set, those functions use the Forward Number.

This feature does not activate the forwarding, it only sets the number for the forwarding destination.

Details

**Telephone Number:** ✓ Telephone number.

**Default Short Code:** ✓ \*57\*N#

**Programmable Button Control:** ✓ FwBNo

**See also:** Forward Number.

**Release:** 1.0+.

Example

N represents the extension number to be forwarded to. For example, if Paul (whose extension is 224) wants to set the forwarding number for his 'Forward on Busy' and/or 'Forward on No Answer' feature to extension 201, Paul can dial \*57\*201# followed by the short code for the forwarding function.

**Short Code:** \*57N\*#

**Telephone Number:** N

**Feature:** ForwardOnBusyNumber

#### Related links

[Short Code Features](#) on page 827

---

## Forward On Busy On

This feature enables forwarding when the user's extension is busy. It uses the Forward Number destination or, if set, the Forward on Busy Number destination. If the user has call appearance buttons programmed, the system will not treat them as busy until all the call appearance buttons are in use.

Release 3.2+: Forward Internal (User | Forwarding) can also be used to control whether internal calls are forwarded.

Details

**Telephone Number:** ✘

**Default Short Code:** ✔ \*03

**Programmable Button Control:** ✔ FwBOn

**See also:** Forward On Busy Off, Cancel All Forwarding, Enable Internal Forward Busy or No Answer.

**Release:** 1.0+.

Example

Below is a sample of the short code setup.

**Short Code:** \*03

**Feature:** ForwardOnBusyOn

### Related links

[Short Code Features](#) on page 827

---

## Forward On Busy Off

This feature cancels forwarding when the user's extension is busy.

Details

**Telephone Number:** ✘

**Default Short Code:** ✔ \*04

**Programmable Button Control:** ✔ FwBOf

**See also:** Forward On Busy On, Cancel All Forwarding.

**Release:** 1.0+.

Example

Below is a sample of the short code setup.

**Short Code:** \*04

**Feature:** ForwardOnBusyOff

**Related links**

[Short Code Features](#) on page 827

---

## Forward On No Answer On

This feature enables forwarding when the user's extension is not answered within the period defined by their No Answer Time. It uses the Forward Number destination or, if set, the Forward on Busy Number destination.

Forward Internal (User | Forwarding) can also be used to control whether internal calls are forwarded.

Details

**Telephone Number:** ✘

**Default Short Code:** ✔ \*05

**Programmable Button Control:** ✔ FwNOn

**See also:** Forward On No Answer Off, Cancel All Forwarding.

**Release:** 1.0+.

Example

Below is a sample of the short code setup. Remember that the forwarding number for this feature uses the 'Forward on Busy Number'.

**Short Code:** \*05

**Feature:** ForwardOnNoAnswerOn

**Related links**

[Short Code Features](#) on page 827

---

## Forward On No Answer Off

This feature cancels forwarding when the user's extension is not answered.

Details

**Telephone Number:** ✘

**Default Short Code:** ✔ \*06



**Programmable Button Control:** ✓ FwNOF

**See also:** Forward On No Answer On.

**Release:** 1.0+.

Example

Below is a sample of the short code setup.

**Short Code:** \*06

**Feature:** ForwardOnNoAnswerOff

#### Related links

[Short Code Features](#) on page 827

---

## Forward Unconditional On

This feature enables forwarding of all calls, except group calls, to the Forward Number set for the user's extension. To also forward hunt group calls, Forward Hunt Group Calls On must also be used. For further details see Forward Unconditional.

Forward Internal (User | Forwarding) can also be used to control whether internal calls are forwarded.

Details

**Telephone Number:** ✗

**Default Short Code:** ✓

**Programmable Button Control:** ✓ FwUOn

**See also:** Forward Unconditional Off.

**Release:** 1.0+.

Example

Remember that this feature requires having a forward number configured.

**Short Code:** \*01

**Feature:** ForwardUnconditionalOn

#### Related links

[Short Code Features](#) on page 827

---

## Forward Unconditional Off

This feature cancels forwarding of all calls from the user's extension.

**\* Note:**

This does not disable Forward on No Answer and or Forward on Busy if those functions are also on. For further details see Forward Unconditional.

### Details

**Telephone Number:** ✘

**Default Short Code:** ✔ \*02

**Programmable Button Control:** ✔ FwUOf

**See also:** Forward Unconditional On.

**Release:** 1.0+.

### Example

Example

Below is a sample of the short code setup.

**Short Code:** \*02

**Feature:** ForwardUnconditionalOff

### Related links

[Short Code Features](#) on page 827

---

## Group Listen Off

Disables the group listen function for the user's extension. See Group Listen On.

Details

**Telephone Number:** ✘

**Default Short Code:** ✘

**Programmable Button Control:** ✔ GroupListenOn

**Release:** 4.1+.

Example

Below is a sample short code using the Group Listen Off feature.

**Short Code:** \*27

**Feature:** GroupListenOff

**Related links**

[Short Code Features](#) on page 827

---

## Group Listen On

Using group listen allows callers to be heard through the phone's handsfree speaker but to only hear the phone's handset microphone. When group listen is enabled, it modifies the handsfree functionality of the user's phone in the following manner

When the user's phone is placed in handsfree/speaker mode, the speech path from the connected party is broadcast on the phone speaker but the phone's base microphone is disabled.

The connected party can only hear speech delivered via the phone's handset microphone.

Group listen is not supported for IP phones or when using a phone's **HEADSET** button.

Currently connected calls are not affected by changes to this setting. If group listen is required it must be selected before the call is connected.

This enables listeners at the user's phone to hear the connected party whilst limiting the connected party to hear only what is communicated via the phone handset.

Details

**Telephone Number:** ✘

**Default Short Code:** ✘

**Programmable Button Control:** ✔ GroupListenOn

**Release:** 4.1+.

Example

Below is a sample short code using the Group Listen Off feature.

**Short Code:** \*28

**Feature:** GroupListenOn

**Related links**

[Short Code Features](#) on page 827

---

## Headset Toggle

Toggles between the use of a headset and the telephone handset.

Details

**Telephone Number:** ✘

**Default Short Code:** ✘

**Programmable Button Control:** ✔ HdSet

**Release:** 1.4+.

Example

Below is a sample short code using the Headset Toggle feature. This short code can be used to toggle the feature on/off. If an Avaya supported headset is connected to your telephone, this short code can be used to toggle between using the headset and the telephone handset.

**Short Code:** \*55

**Feature:** HeadsetToggle

### Related links

[Short Code Features](#) on page 827

---

## Hold Call

This uses the Q.931 Hold facility, and "holds" the incoming call at the ISDN exchange, freeing up the ISDN B channel. The Hold Call feature "holds" the current call to a slot. The current call is always automatically placed into slot 0 if it has not been placed in a specified slot. Only available if supported by the ISDN exchange.

Details

**Telephone Number:** ✔ Exchange hold slot number or blank (slot 0).

**Default Short Code:** ✘

**Programmable Button Control:** ✔ Hold

**See also:** Hold CW, Hold Music, Suspend Call.

**Release:** 1.0+.

Example

Below is a sample short code using the Hold Call feature. This short code is a default within the system configuration. N represents the exchange hold slot number you want to hold the call on. For example, while connected to a call, dialing \*24\*3# will hold the call onto slot 3 on the ISDN.

**Short Code:** \*24\*N#

**Telephone Number:** N

**Feature:** HoldCall

### Related links

[Short Code Features](#) on page 827

---

## Hold CW

This uses the Q.931 Hold facility, and "holds" the incoming call at the ISDN exchange, freeing up the ISDN B channel. The Hold CW feature "holds" the current call to an exchange slot and answers the call waiting. The current call is always automatically placed into slot 0 if it has not been placed in a specified slot. Only available if supported by the ISDN exchange.

### Details

**Telephone Number:** ✓ Exchange slot number or blank (slot 0).

**Default Short Code:** ✓ \*27\*N# (A-Law only) (not on Server Edition)

**Programmable Button Control:** ✓ HoldCW

**See also:** Hold Call, Suspend Call.

**Release:** 1.0+.

### Example

Below is a sample short code using the Hold CW feature.

**Short Code:** \*27\*N#

**Feature:** HoldCW

### Related links

[Short Code Features](#) on page 827

---

## Hold Music

This feature allows the user to check the system's music on hold. See Music On Hold for more information.

### Details

**Telephone Number:** Optional. If no number is specified, the default system source is assumed. The system supports up to 4 hold music sources, numbered 1 to 4. 1 represents the System Source. 2 to 4 represent the Alternate Sources.

**Default Short Code:** ✓

\*34N; where N is the number of the hold music source required.

**Programmable Button Control:** ✓ Music

**Release:** 1.0+.

### Example

Below is a sample short code using the Hold Music feature. This short code is a default within the configuration.

**Short Code:** \*34N;

**Feature:** HoldMusic

**Related links**

[Short Code Features](#) on page 827

---

## Hunt Group Disable

This feature disables the user's membership of the specified hunt group. They will no longer receive call to that hunt group until their membership is enabled again. To use this feature, you must already belong to the hunt group. See also Hunt Group Enable.

Details

**Telephone Number:** ✓ Group number.

**Default Short Code:** ✗

**Programmable Button Control:** ✓ HGDis

**See also:** Hunt Group Enable.

**Release:** 1.0+.

Example

N represents the hunt group number from which the user wants to be disabled from. For example, if Paul wants to be disabled from the Sales hunt group (extrn. 500), he needs to dial \*90\*500#.

**Short Code:** \*90\*N#

**Telephone Number:** N

**Feature:** HuntGroupDisable

**Related links**

[Short Code Features](#) on page 827

---

## Hunt Group Enable

This feature enables the user's membership of a hunt group so they can begin to receive calls to the specified hunt group. To use this feature, the user must already belong to the hunt group. This short code can not be used to add someone to a hunt group, that must be done within Manager's Hunt Group form.

Details

**Telephone Number:** ✓ Group number.

**Default Short Code:** ✘

**Programmable Button Control:** ✔ HGE<sub>na</sub>

**See also:** Hunt Group Disable.

**Release:** 1.0+. Previously in Release 3.2 the **Set Hunt Group Night Service**, **Set Hunt Group Out of Service** and **Hunt Group Enable** short code features toggled. That behaviour is not supported in 4.0 and higher.

Example

This short code can be used to turn the feature on. N represents the hunt group number for which the user wants to start receiving calls. For example, if Paul is already a member of the sales hunt group (extn. 500) but has changed his availability status for that hunt group using hunt group disable, he can make himself available for receiving calls to the Sales hunt group again by dialing \*91\*500#.

**Short Code:** \*91\*N#

**Telephone Number:** N

**Feature:** HuntGroupEnable

#### Related links

[Short Code Features](#) on page 827

## Last Number Redial

This feature allows an extension to redial the last number they dialed.

Details

**Telephone Number:** ✘

**Default Short Code:** ✘

**Programmable Button Control:** ✘

**Release:** 3.0+.

#### Related links

[Short Code Features](#) on page 827

## MCID Activate

This feature should only be used in agreement with the ISDN service provider and the appropriate local legal authorities. It allows users with **Can Trace Calls (User | Telephony | Supervisor**

**Settings**) set to trigger a malicious call trace of their previous call at the ISDN exchange. Refer to Telephone Features Malicious Call Tracing for further details.

 **Note:**

Currently, in Server Edition network, MCID is only supported for users using an MCID button and registered on the same IP500 V2 Expansion system as the MCID trunks.

Details

**Telephone Number:** ✘

**Default Short Code:** ✘

**Programmable Button Control:** Advanced | Miscellaneous | MCID Activate.

**Release:** 4.0+.

**Related links**

[Short Code Features](#) on page 827

---

## Mobile Twinned Call Pickup

This short code feature allows the user to pickup a call ringing or connected at the destination of their mobile twinning number. This short code can only be used from the primary extension which is being used for the twinning operation.

Note that the use of mobile twinning requires entry of a Mobile Twinning license and may be subject to a time profile.

Details

**Telephone Number:** ✘

**Default Short Code:** ✘

**Programmable Button Control:** ✘

**See also:** Set Mobile Twinning Number, Set Mobile Twinning On, Set Mobile Twinning Off.

**Release:** 3.2+.

**Related links**

[Short Code Features](#) on page 827



---

## Off Hook Station

Enables or disables whether the user's extension acts as a fully handsfree unit. Typically this is used when the answering and clearing of calls is done through an application. For more details see [Off Hook Station \(User | Telephony | Call Settings\)](#).

Details

**Telephone Number:** ✓ "Y" for on or "N" for off.

**Default Short Code:** ✗

**Programmable Button Control:** ✓ OHStn

**Release:** 1.0+.

Example: Turning the off hook station off

**Short Code:** \*89

**Telephone Number:** N

Feature: OffHookStation

Example: Turning the off hook station on

**Short Code:** \*98

**Telephone Number:** Y

**Feature:** OffHookStation

### Related links

[Short Code Features](#) on page 827

---

## Outgoing Call Bar Off

Allows a user to switch off their outgoing call bar status. The short code user must enter their log in code, if set, in order to be successful.

If you add a short code using this feature to a system it is recommended that you also assign a login code to the No User user to prevent the short code being used to change the status of that user.

Details

**Telephone Number:** ✓ The user's log in code.

System phone users can use `<target user>*<system phone user's login code>`.

**Default Short Code:** ✗

**Programmable Button Control:** ✗

**Release:** 4.1+ (Added to Release 4.1 2008Q2 Maintenance release).

Example

The user has a **Login Code** of **1234**. To use the short code below below, the user must dial **\*59\*1234#**.

**Short Code:** \*59\*N#

**Telephone Number:** N

**Feature:** Outgoing Call Bar Off.

Example

A user set as a system phone can also switch off the Outgoing Call Bar status of another user. This is done using their own login code. For example the system phone 401 with login code 1234 can switch off the outgoing call bar status of extension 403 as follows:

**\*59\*403\*1234**

#### Related links

[Short Code Features](#) on page 827

---

## Outgoing Call Bar On

Allows a user to switch on their outgoing call bar status.

Details

**Telephone Number:** ✘

**Default Short Code:** ✘

**Programmable Button Control:** ✘

**Release:** 4.1+ (Added to Release 4.1 2008Q2 Maintenance release).

Example

To use the short code below below, the user must dial **\*58**.

**Short Code:** \*58

**Telephone Number:** <blank>

**Feature:** Outgoing Call Bar On.

#### Related links

[Short Code Features](#) on page 827

---

## Private Call Off

Short codes using this feature turn off private call status for the user if set. The short code features Private Call and Private Call On can be used to turn private call on.

When on, any subsequent calls cannot be intruded on until the user's private call status is switched off. The exception is Whisper Page which can be used to talk to a user on a private call.

Note that use of private calls is separate from the user's intrusion settings. If the user's **Cannot be Intruded** (User | Telephony | Supervisor Settings) setting is enabled, switching private calls off does not affect that status. To allow private calls to be used to fully control the user status, **Cannot be Intruded** (User | Telephony | Supervisor Settings) should be disabled for the user.

Details

**Telephone Number:** ✘

**Default Short Code:** ✘

**Programmable Button Control:** Advanced | Call | Private Call.

**Release:** 4.0+.

### Related links

[Short Code Features](#) on page 827

---

## Private Call On

Short codes using this feature turn on the private call settings for the user regardless.

When on, any subsequent calls cannot be intruded on until the user's private call status is switched off. The exception is Whisper Page which can be used to talk to a user on a private call.

Note that use of private calls is separate from the user's intrusion settings. If the user's **Cannot be Intruded** (User | Telephony | Supervisor Settings) setting is enabled, switching private calls off does not affect that status. To allow private calls to be used to fully control the user status, **Cannot be Intruded** (User | Telephony | Supervisor Settings) should be disabled for the user.

Private call status can be switched off using a short code with the Private Call Off feature or a programmed button set to the Private Call action. To enable private call status for a single following call only the Private Call short code feature should be used.

Details

**Telephone Number:** ✘

**Default Short Code:** ✘

**Programmable Button Control:** Advanced | Call | Private Call.

**Release:** 4.0+.

## Related links

[Short Code Features](#) on page 827

---

# Priority Call

This feature allows the user to call another user even if they are set to 'do not disturb'. Priority calls to a user without DND will follow forwarding and follow me settings but will not go to voicemail.

Details

**Telephone Number:** ✓ Extension number.

**Default Short Code:** ✗

**Programmable Button Control:** ✓ PCall

**See also:** DialPhysicalExtensionByNumber, DialPhysicalNumberByID.

**Release:** 1.0+.

Example

N represents the extension number to be called, despite the extension being set to 'do not disturb'. For example, if extension 201 has 'do not disturb' enabled, a user can dial \*71\*201# and still get through. This short code is useful for companies that frequently use the 'do not disturb' feature and can be given to Managing Directors or people who may need to get through to people regardless of their 'do not disturb' status.

**Short Code:** \*71\*N#

**Telephone Number:** N

**Feature:** PriorityCall

## Related links

[Short Code Features](#) on page 827

---

# Record Message

This short code feature is used to record hunt group announcements on Embedded Voicemail, see Hunt Group | Announcements. Release 5.0+: It is also used to record mailbox user name prompts for the auto attendant **Dial by Name** function.

Details

**Telephone Number:** ✓

For a hunt group queue announcement, use the hunt group extension number followed by ".1".

For a hunt group still queue announcement, use the hunt group extension number followed by ".2".

For a mailbox user name prompt, use the user extension number followed by ".3".

**Default Short Code:** ✓ \*91N; and \*92N; (not on Server Edition)

**Programmable Button Control:** ✗

**Release:** 4.0+.

Example

For a hunt group with extension number 300, the default short codes **\*91N;/Record Message/N".1"** and **\*92N;/Record Message/N".2"** can be used to allow recording of the announcements by dialing **\*91300#** and **\*92300#**.

To allow users to record their own name prompt, the short code **\*89#/Record Message/E."3"** can be used. The **E** is replace by the extension number of the dialing user.

### Related links

[Short Code Features](#) on page 827

---

## Relay On

This feature closes the specified switch in the system's external output (EXT O/P) port.

This feature is not supported on Linux based systems. For Server Edition, this option is only supported on Expansion System (V2) units.

Details

**Telephone Number:** ✓ Switch number (1 or 2).

**Default Short Code:** ✓ \*39 (Switch 1), \*42 (Switch 2), \*9000\*.

**Programmable Button Control:** ✓ Rely+

**See also:** Relay Off, Relay Pulse.

**Release:** 1.0+.

Example

This short code is a default within the system configuration. This short code is useful for companies that have external devices, such as door controls, connected to the system. Based on this sample short code, a user dialing \*42 is closing switch number 2 to activate an external device.

**Short Code:** \*42

**Telephone Number:** 2

**Feature:** RelayOn

### Analog Modem Control

On systems with an analog trunk card in the control unit, the first analog trunk can be set to answer V.32 modem calls. This is done by either selecting the Modem Enabled option on the analog line settings or using the default short code \*9000\* to toggle this service on or off. This short code uses the **RelayOn** feature with the Telephone Number set to "MAINTENANCE". Note that the short code method is always returned to off following a reboot or if used for accessing the system date and time menu.

**IP500 ATM4 Uni Trunk Card Modem Support** It is not required to switch the card's modem port on/off. The trunk card's V32 modem function can be accessed simply by routing a modem call to the RAS service's extension number. The modem call does not have to use the first analog trunk, instead the port remains available for voice calls.

### Related links

[Short Code Features](#) on page 827

---

## Relay Off

This feature opens the specified switch in the system's external output (EXT O/P) port.

Details

**Telephone Number:** ✓ Switch number (1 or 2).

**Default Short Code:** ✓ \*40 (Switch 1), \*43 (Switch 2)

**Programmable Button Control:** ✓ Rely-

**See also:** Relay On, Relay Pulse.

**Release:** 1.0+.

Example

This short code is a default within the system configuration. This short code is useful for companies that have external devices, such as door controls, connected to the system. Based on this sample short code, a user dialing \*43 is opening switch number 2 to activate an external device.

**Short Code:** \*43

**Telephone Number:** 2

**Feature:** RelayOff

### Related links

[Short Code Features](#) on page 827

---

## Relay Pulse

This feature closes the specified switch in the system's external output (EXT O/P) port for 5 seconds and then opens the switch.

### Details

**Telephone Number:** ✓ Switch number (1 or 2).

**Default Short Code:** ✓ \*41 (Switch 1), \*44 (Switch 2)

**Programmable Button Control:** ✓ Relay

**See also:** Relay On, Relay Off.

**Release:** 1.0+.

### Example

This short code is a default within the system configuration. This short code is useful for companies that have external devices, such as door controls, connected to the system. Based on this sample short code, a user dialing \*44 is opening switch number 2 to activate an external device.

**Short Code:** \*44

**Telephone Number:** 2

**Feature:** RelayPulse

### Related links

[Short Code Features](#) on page 827

---

## Resume Call

Resume a call previously suspended to the specified ISDN exchange slot. The suspended call may be resumed from another phone/ISDN Control Unit on the same line.

### Details

**Telephone Number:** ✓ Exchange suspend slot number.

**Default Short Code:** ✓ \*23\*N# (A-Law only) (not on Server Edition)

**Programmable Button Control:** ✓ Resum

**See also:** Suspend Call.

**Release:** 1.0+.

### Example

Below is sample short code using the Resume Call feature. N represents the exchange slot number from which the call has been suspended. For example, if a user has suspended a call on slot number 4, this user can resume that call by dialing \*23\*4#.

**Short Code:** \*23\*N#

**Telephone Number:** N

**Feature:** ResumeCall

#### Related links

[Short Code Features](#) on page 827

---

## Retrieve Call

Retrieves a call previously held to a specific ISDN exchange slot.

Details

**Telephone Number:** ✓ Exchange hold slot number.

**Default Short Code:** ✓ \*25\*N# (A-Law only) (not on Server Edition)

**Programmable Button Control:** ✓ Retriv

**See also:** Hold Call.

**Release:** 1.0+.

Example

Below is sample short code using the Retrieve Call feature. N represents the exchange slot number from which the call has been placed on hold. For example, if a user has placed a call hold on slot number 4, the user can resume that call by dialing \*25\*4#.

**Short Code:** \*25\*N#

**Telephone Number:** N

**Feature:** RetrieveCall

#### Related links

[Short Code Features](#) on page 827

---

## Ring Back When Free

This feature sets a ringback on the specified extension. This sets a 'ringback when free' on an extension currently on a call or a 'ringback when next used' for an extension that is free but does not answer.



When the target extension is next used or ends its current call, the users is rung and when they answer a call is made to the target extension.

Details

**Telephone Number:** ✓ Target extension number.

**Default Short Code:** ✗

**Programmable Button Control:** ✓ RBak+

**See also:** Cancel Ring Back When Free.

**Release:** 1.0+.

Example

N represents the target extension from which you want to receive the callback. For example, if you call extension 201 but the line is busy, hang up and then dial \*71\*201#. When extension 201 disconnects from its current call, your phone will ring. Once you pick up the phone, extension 201's line will start ringing to indicate an incoming call.

**Short Code:** \*71\*N#

**Telephone Number:** N

**Feature:** RingBackWhenFree

#### Related links

[Short Code Features](#) on page 827

---

## Secondary Dial Tone

Secondary dial tone is a system feature to generate a secondary dial tone after the user has begun dialing an external number. This dial tone is then played until the number dialing and an external trunk seized.

Pre-Release 4.0: Secondary dial tone is triggered through the use of the secondary dial tone short code feature.

Release 4.0+: The use of this short code feature has been replaced by the Secondary Dial Tone check box option on ARS forms.

Details

**Telephone Number:** ✓ Digit which triggers secondary dial tone.

**Default Short Code:** ✓ 9 (U-Law only)

**Programmable Button Control:** ✗

**Release:** 1.0+.

Example

For pre-4.0 systems secondary dial tone works in two parts. The following system short code will trigger secondary dial tone. To use it to trigger secondary dial tone and then continue dialing, other user, user rights and system short codes should begin with [9].

**Short Code:** 9

**Telephone Number:** .

**Feature:** Secondary Dial Tone

#### Related links

[Short Code Features](#) on page 827

## Set Absent Text

This feature can be used to select the user's current absence text. This text is then displayed to internal callers who have suitable display phones or applications. It doesn't change the user's status. The absence text message is limited to 128 characters. Note however that the amount displayed will depend on the caller's device or application.

The text is displayed to callers even if the user has forwarded their calls or is using follow me. Absence text is supported across a multi-site network.

#### Details

**Telephone Number:** ✓ The telephone number should take the format "**y,n,text**" where:

- **y** = 0 or 1 to turn this feature on or off.
- **n** = the number of the absent statement to use, see the list below:

0 = None.	4 = Meeting until.	8 = With cust. til.
1 = On vacation until.	5 = Please call.	9 = Back soon.
2 = Will be back.	6 = Don't disturb until.	10 = Back tomorrow.
3 = At lunch until.	7 = With visitors until.	11 = Custom.

**text** = any text to follow the absent statement.

**Default Short Code:** ✗

**Programmable Button Control:** ✓ Absnt

**Release:** 1.0+.

#### Example

The following short code can be used to turn an absent text message on:

- **Short Code:** \*88
- **Telephone Number:** "1,5,me on 208"

- **Line Group ID:** 0
- **Feature:** SetAbsentText

#### Example

The following short code could be used to turn this facility off. In the Telephone Number the first 0 is used to turn this facility off and the second 0 is used to select the absent statement "None".

**Short Code:** \*89

**Telephone Number:** "0,0"

**Line Group ID:** 0

**Feature:** SetAbsentText

#### Related links

[Short Code Features](#) on page 827

---

## Set Account Code

This short code feature is used to allow system users to enter a valid account code prior to making a phone call. Once this short code is set up, any existing account code in the system configuration can be used in conjunction with it.

This short code feature is essential for allowing analog phone users to enter account codes as they cannot enter account code through the phone during a call or after dial a number.

#### Details

**Telephone Number:** ✓ A valid account code.

**Default Short Code:** ✗

**Programmable Button Control:** ✓ Acct.

**Release:** 2.1+.

#### Example

In this example, N represents any valid account code. For the purpose of this example, we will imagine the account code to be 1234. Once this short code is created, a user can dial 11\*1234# to get a dial tone for dialing the restricted telephone number or the phone number needing to be tracked for billing purposes.

**Short code:** 11\*N#

**Telephone Number:** N

**Feature:** SetAccountCode

#### Related links

[Short Code Features](#) on page 827

---

## Set Authorization Code

This short code feature is only available on systems configured to use authorization codes. See Authorization Codes. The feature is used to allow a user to enter a valid authorization code prior to making a phone call.

This short code feature is essential for allowing analog phone users to enter authorization codes. Note that the authorization code must be associated with the user or the user rights to which the user belongs.

Details

**Telephone Number:** ✓ A valid authorization code.

**Default Short Code:** ✗

**Programmable Button Control:** ✗

**Release:** 3.2+.

### Related links

[Short Code Features](#) on page 827

---

## Set Fallback Twinning Off

This feature can be used by users to disable fallback twinning operation. This feature requires the user to have a mobile twinning number set.

Fallback twinning redirects calls to the user's configured mobile twinning number when the system cannot detect a connection to the user's normal registered extension. This feature can be used without mobile twinning itself being enabled.

Details

- **Telephone Number:** ✗
- **Default Short Code:** ✗
- **Programmable Button Control:** ✗

### Related links

[Short Code Features](#) on page 827

---

## Set Fallback Twinning On

This feature can be used by users to enable fallback twinning operation. This feature requires the user to have a mobile twinning number set.

Fallback twinning redirects calls to the user's configured mobile twinning number when the system cannot detect a connection to the user's normal registered extension. This feature can be used without mobile twinning itself being enabled.

### Details

- **Telephone Number:** ✘
- **Default Short Code:** ✘
- **Programmable Button Control:** ✘

### Related links

[Short Code Features](#) on page 827

---

## Set Hunt Group Night Service

This feature puts the specified hunt group into Night Service mode.

Setting and clearing hunt group night service can be done using either manual controls or using a system time profile. The use of both methods to control the night service status of a particular hunt group is not supported.

This function is not supported between systems in a multi-site network. It can only be used by a user currently logged onto the same system as hosting the hunt group.

### Details

**Telephone Number:** ✔ Hunt group extension number. If left blank, the short code will affect all hunt groups of which the user is a member.

The **Set Hunt Group Night Service** and **Clear Hunt Group Night Service** short code and button features can be used to switch an SSL VPN service off or on respectively. The service is indicated by setting the service name as the telephone number or action data. Do not use quotation marks.

**Default Short Code:** ✔ \*20\*N#

**Programmable Button Control:** ✔ HGNS+

**See also:** Set Hunt Group Out Of Service, Clear Hunt Group Night Service, Clear Hunt Group Out Of Service.

**Release:** 1.0+.

### Example

This short code is a default within the system configuration. N represents the telephone number of the hunt group to be placed into "Night Service" mode. For example, when \*20\*201# is dialed, the hunt group associated with extension 201 will be placed into "Night Service" mode.

**Short Code:** \*20\*N#

**Telephone Number:** N

**Feature:** SetHuntGroupNightService

## Related links

[Short Code Features](#) on page 827

---

# Set Hunt Group Out Of Service

This feature manually puts the specified hunt group into Out of Service mode. If a time profile has also been defined to control hunt group night service, the action may vary:

**Set Hunt Group Out of Service** can be used to override a time profile and change a hunt group from night service to out of service.

Details

**Telephone Number:** ✓ Hunt group extension number. For Release 4.0+, if left blank, the short code will affect all hunt groups of which the user is a member.

**Default Short Code:** ✗

**Programmable Button Control:** ✓ HGOS+

**Release:** 1.0+.

Example

Below is a sample short code using the **Set Hunt Group Out Of Service** feature. N represents the telephone number of the hunt group to be placed into "Out of Service" mode. For example, when \*56\*201# is dialed, the hunt group associated with extension 201 will be placed into "Out of Service" mode.

**Short Code:** \*56\*N#

**Telephone Number:** N

**Feature:** SetHuntGroupOutOfService

## Related links

[Short Code Features](#) on page 827

---

# Set Inside Call Seq

This feature allows the user to select the ringing used on their analog extension for internal calls.

The number entered corresponds to the ring pattern required. This is 0 for Default Ring, 1 for RingNormal, 2 for RingType1, etc. For more information on selectable ringing patterns, see Ring Tones. Use of this short code function is applicable to analog phone users only. The distinctive ringing pattern used for other phones is set by the phone type.

Details

**Telephone Number:** ✓ Number corresponding to the desired ring pattern. See Ring Tones.

**Default Short Code:** ✗

**Programmable Button Control:** ✓ ICSeq

**See also:** Set Ringback Seq, Set Inside Call Seq.

**Release:** 1.0+.

Example

This Short Code allows a user to change their inside call pattern. N represents the number corresponding to the Call Sequence the user wishes to choose, the numbering starts at 0 selecting Default Ring, 1 selects Ring Normal, 2 selects RingType1, etc. For example, if a user wants to set her/his internal ring pattern to RingType1, the user would dial \*80\*2# because 2 corresponds to RingType1. This short code is useful for distinguishing an external call from an internal one simply by the ring tone.

**Short Code:** \*80\*N#

**Telephone Number:** N

**Feature:** SetInsideCallSeq

#### Related links

[Short Code Features](#) on page 827

## Set Mobile Twinning Number

This short code feature can be used to set a mobile twinning number. The destination can be any external number the user is able to dial normally. It should include any prefix if necessary.

Details

**Telephone Number:** ✓ Twinning destination.

**Default Short Code:** ✗

**Programmable Button Control:** ✗

**See also:** Set Mobile Twinning On, Set Mobile Twinning Off, Mobile Twinned Call Pickup.

**Release:** 3.2+.

#### Related links

[Short Code Features](#) on page 827

---

## Set Mobile Twinning On

This short code feature turns on the user's mobile twinning. It requires a mobile twinning number to have been set for the user. That can be done through using the Set Mobile Twinning Number short code feature or through the User | Twinning tab within Manager.

Details

**Telephone Number:** ✘

**Default Short Code:** ✘

**Programmable Button Control:** ✘

**See also:** Set Mobile Twinning Off, Set Mobile Twinning Number, Mobile Twinned Call Pickup.

**Release:** 3.2+.

### Related links

[Short Code Features](#) on page 827

---

## Set Mobile Twinning Off

This short code feature turns off the user's mobile twinning.

Details

**Telephone Number:** ✘

**Default Short Code:** ✘

**Programmable Button Control:** ✘

**See also:** Set Mobile Twinning On, Set Mobile Twinning Number, Mobile Twinned Call Pickup.

**Release:** 3.2+.

### Related links

[Short Code Features](#) on page 827

---

## Set No Answer Time

This short code feature allows the user to change their No Answer Time (User | Telephony | Call Settings).

Details

**Telephone Number:** ✔ Time in seconds.



**Default Short Code:** ✘

**Programmable Button Control:** ✔ NATim

**See also:** Set Wrap Up Time.

**Release:** 1.0+.

Example

This short code allows a user to change the length of time they have to answer the phone before it goes to divert or voicemail. N represents the number of seconds. For example, if a user wants to set the no answer time to 15 seconds, the following information needs to be entered: \*81\*15#.

**Short Code:** \*81\*N#

**Telephone Number:** N

**Feature:** SetNoAnswerTime

#### Related links

[Short Code Features](#) on page 827

---

## Set Outside Call Seq

This feature allows the user to select the ringing used on their analog extension for external calls.

The number entered corresponds to the ring pattern required. This is 0 for Default Ring, 1 for RingNormal, 2 for RingType1, etc. For more information on selectable ringing patterns, see Ring Tones. Use of this short code function is applicable to analog phone users only. The distinctive ringing pattern used for other phones is set by the phone type.

Details

**Telephone Number:** ✔ Number corresponding to the desired ring pattern. See Ring Tones.

**Default Short Code:** ✘

**Programmable Button Control:** ✔ OCSeq

**See also:** Set Ringback Seq, Set Outside Call Seq.

**Release:** 1.0+.

Example

This short code allows a user to change the ringing tone for an external call. N represents the number corresponding to the Call Sequence the user wishes to choose, the numbering starts at 0 selecting Default Ring, 1 selects RingNormal, 2 selects RingType1, etc. For example, if a user wants to set her/his ring pattern for external calls to RingType1, the user would dial \*81\*2# because 2 corresponds to RingType1. This short code is useful for distinguishing an external call from an internal one simply by the ring tone.

**Short Code:** \*81\*N#

**Telephone Number:** N

**Feature:** SetOutsideCallSeq

**Related links**

[Short Code Features](#) on page 827

## Set Ringback Seq

This feature allows the user to select the ringing used on their analog extension for ringback calls.

The number entered corresponds to the ring pattern required. This is 0 for Default Ring, 1 for RingNormal, 2 for RingType1, etc. For more information on selectable ringing patterns, see Ring Tones. Use of this short code function is applicable to analog phone users only. The distinctive ringing pattern used for other phones is set by the phone type.

**Telephone Number:** ✓ Number corresponding to the desired ring pattern. See Ring Tones.

**Default Short Code:** ✗

**Programmable Button Control:** ✓ RBSeq

**See also:** Set Outside Call Seq, Set Inside Call Seq.

### Example

This short code allows a user to change the ringing tone for a ringback call. N represents the number corresponding to the ring tone the user wishes to choose, the numbering starts at 0 selecting Default Ring, 1 selects RingNormal, 2 selects RingType1, etc. For example, if a user wants to set her/his ring pattern for ringback calls to RingType1, the user would dial \*81\*2# because 2 corresponds to RingType1. This short code is useful for distinguishing a ringback call from any other call simply by the ring tone.

**Short Code:** \*81\*N#

**Telephone Number:** N

**Feature:** SetRingbackSeq

**Related links**

[Short Code Features](#) on page 827

## Set Time Profile

You can manually override a time profile. The override settings allow you to mix timed and manual settings.

Five short codes can be configured.

Short Code Name	Description
<b>Set Time Profile Timed Operation</b>	No override. The time profile operates as configured.
<b>Set Time Profile Active Until Next Timed Inactive</b>	Use for time profiles with multiple intervals. Select to make the current timed interval active until the next inactive interval.
<b>Set Time Profile Inactive Until Next Timed Active</b>	Use for time profiles with multiple intervals. Select to make the current active timed interval inactive until the next active interval.
<b>Set Time Profile Latch Active</b>	Set the time profile to active. Timed inactive periods are overridden and remain active.
<b>Set Time Profile Latch Inactive</b>	Set the time profile to inactive. Timed active periods are overridden and remain active.

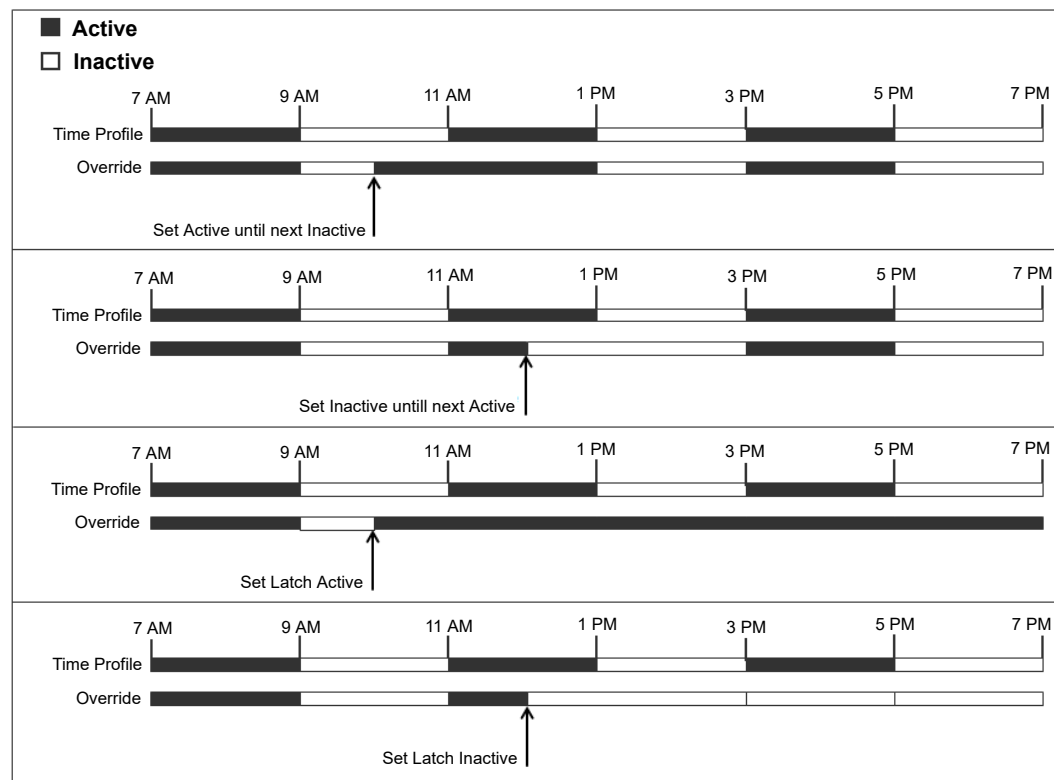

**Telephone Number:** Time profile name.

**Default Short Code:** No.

**Programmable Button Control:** Yes: Time Profile

## Related links

[Short Code Features](#) on page 827

---

# Set Wrap Up Time

Allows users to change their Wrap-up Time (User | Telephony | Call Settings) setting.

Other phones or applications monitoring the user's status will indicate the user as still being busy (on a call).

Hunt group calls will not be presented to the user.

If the user is using a single line set, direct calls also receive busy treatment. If the user is using a multi-line set (multiple call appearances), direct calls to them will ring as normal.

It is recommended that this option is not set to less than the default of 2 seconds. 0 is used to allow immediate ringing.

For users set as an CCR Agent, the After Call Work Time (User | Telephony | Supervisor Settings) setting should be used.

Details

**Telephone Number:** ✓ Time in seconds.

**Default Short Code:** ✗

**Programmable Button Control:** ✓ WUTim

**See also:** Set No Answer Time.

**Release:** 1.0+.

Example

N represents the number of seconds. For example, if a user wants to set her/his wrap up time to 8 seconds, this user would dial \*82\*5#. This short code is useful in a "call center" environment where users may need time to log call details before taking the next call. If set to 0 the user does not receive any calls. It is recommended that this option is not set to less than the default of 2 seconds.

**Short Code:** \*82\*N#

**Telephone Number:** N

**Feature:** SetWrapUpTime

## Related links

[Short Code Features](#) on page 827

---

## Speed Dial

Each system directory and personal directory number stored in the configuration can be optionally assigned an index number. That index number can then be used by M-Series and T-Series phone users to dial the directory number. This short code feature allows the creation of short codes to perform the same function. However, the short code is diallable from any type of telephone extension on the system.

For example:

- If **Feature 0** is followed by a 3-digit index number in the range 000 to 999, the system directory record with the matching index number is dialed.
- If **Feature 0** is followed by \* and a 2-digit index number in the range 00 to 99, the personal directory record with the matching index number is dialed. Alternatively Feature 0 can be followed by 00# to 99#. Note: Release 10.0 allows users to have up to 250 personal directory entries. However, only 100 of those can be assigned index numbers.

Details

**Telephone Number:** ✓ System directory entry index number (000 to 999) or personal directory entry index number (00 to 99).

**Default Short Code:** ✗

**Programmable Button Control:** ✗

**Release:** 8.1.

Example

Using the example below, a user is able to dial \*0 and then either a 2 digit code for an indexed personal directory entry or a 3 digit code for an indexed system directory entry.

**Short Code:** \*0N#

**Telephone Number:** N

**Feature:** Speed Dial

### Related links

[Short Code Features](#) on page 827

---

## Shutdown Embedded Voicemail

Allows the Embedded Voicemail service provided by an Avaya memory card in a control unit to be shut down. To restart the service, a **Startup Embedded Voicemail** short code should be used.

The short code has the following effects:

1. Immediately disconnect all current users within Embedded Voicemail. This is not a polite shutdown.

2. Mark the Embedded Voicemail as inactive so that it will not receive any new calls.

Details

**Telephone Number:** ✘

**Default Short Code:** ✘

**Programmable Button Control:** ✘

**Release:** 4.0+ (Added in the Release 4.0 Q2 2007 maintenance release).

#### Related links

[Short Code Features](#) on page 827

---

## Stamp Log

The stamp log function is used to insert a line into any System Monitor trace that is running. The line in the trace indicates the date, time, user name and extension plus additional information. The line is prefixed with **LSTMP: Log Stamped** and a log stamp number. When invoked from a Avaya phone with a display, **Log Stamped#** is also briefly displayed on the phone. This allows users to indicate when they have experienced a particular problem that the system maintainer want them to report and allows the maintainer to more easily locate the relevant section in the monitor trace.

The log stamp number is set to 000 when the system is restarted. The number is then incremented after each time the function is used in a cycle between 000 and 999. Alternately if required, a specific stamp number can be assigned to the button or short code being used for the feature.

Details

**Telephone Number:** Optional. If not set, a number in the sequence 000 to 999 is automatically used. If set, the number set is used.

**Default Short Code:** ✔ \*55

**Programmable Button Control:** ✔ Stamp Log

**Release:** 8.1+

#### Related links

[Short Code Features](#) on page 827

---

## Startup Embedded Voicemail

Restarts the Embedded Voicemail service provided by an Avaya Memory in a control unit.

Details

**Telephone Number:** ✘

**Default Short Code:** ✘

**Programmable Button Control:** ✘

**Release:** 6.0+

#### Related links

[Short Code Features](#) on page 827

---

## Suspend Call

This feature uses the Q.931 Suspend facility. It suspends the incoming call at the ISDN exchange, freeing up the ISDN B channel. The call is placed in exchange slot 0 if a slot number is not specified.

Details

**Telephone Number:** ✔ Exchange slot number or blank (slot 0).

**Default Short Code:** ✘

**Programmable Button Control:** ✔ Suspe

**See also:** Resume Call.

**Release:** 1.0+.

#### Related links

[Short Code Features](#) on page 827

---

## Suspend CW

This feature uses the Q.931 Suspend facility. Suspends the incoming call at the ISDN exchange and answer the call waiting. The call is placed in exchange slot 0 if a slot number is not specified. Only available when supported by the ISDN exchange.

Details

**Telephone Number:** ✔ Exchange slot number or blank (slot 0).

**Default Short Code:** ✔ \*28\*N# (A-Law only) (not on Server Edition)

**Programmable Button Control:** ✔ SusCW

**See also:** Resume Call.

**Release:** 1.0+.

### Example

Sample short code using the Suspend CW feature.

**Short Code:** \*28\*N#

**Feature:** Suspend CW

### Related links

[Short Code Features](#) on page 827

---

## Start After Call Work

This feature can be used by users who have been configured as CCR agents. It allows them to dial a short code to enter the After Call Work (ACW) state as reported by the Customer Call Reporter (CCR) application.

### Note:

CCR is not supported in IP Office release 9.1 and later.

### Details

**Telephone Number:** ✘

**Default Short Code:** ✘

**Programmable Button Control:** ✔ ACWrk

**See also:** Clear After Call Work.

**Release:** 4.2 4Q 2008 Maintenance release+.

### Related links

[Short Code Features](#) on page 827

---

## Toggle Calls

This feature cycles through each call that the user has on hold on the system. This feature is useful when a user with a single-line telephone has several calls on hold and needs to respond to each one in turn.

### Details

**Telephone Number:** ✘

**Default Short Code:** ✔ \*29

**Programmable Button Control:** ✔ Toggl



**Release:** 1.0+.

Example

Below is sample short code using the Toggle Calls feature.

**Short Code:** \*29

**Feature:** ToggleCalls

#### Related links

[Short Code Features](#) on page 827

---

## Unpark Call

Retrieve a parked call from a specified system park slot.

Details

**Telephone Number:** ✓ System park slot number.

**Default Short Code:** ✓ \*38\*N#

**Programmable Button Control:** ✓ Ride

**See also:** Call Park.

**Release:** 1.0+.

Example

Below is a sample short code using the Unpark Call feature. N represents the park slot number in which the call you want to retrieve was parked. For example, if a user parked a call to slot number 9, you can retrieve that call by dialing \*38\*9#.

**Short Code:** \*38\*N#

**Telephone Number:** N

**Feature:** Unpark Call

#### Related links

[Short Code Features](#) on page 827

---

## Voicemail Collect

This feature connects to the voicemail system. Normally the telephone number field is used to indicate the name of the mailbox to be accessed, for example "?Extn201" or "#Extn201".

? indicates 'collect messages'.

# indicates 'leave a message'. It also instructs the voicemail server to give a brief period of ringing before connecting the caller. This is useful if the short code is used for functions like call transfers as otherwise the voicemail server can start playing prompts before the transfer is completed. However, the # can be omitted for immediate connection if required.

" " quotation marks must be used to enclose any information that needs to be sent to the voicemail server as is. Any text not enclosed by quote marks is checked by the telephone system for short code character matches which will be replaced before being sent to the voicemail server.

Manager will automatically add quotation marks to the Telephone Number field if there are no manually added quotation marks. Care should be taken to ensure that special characters that you want replaced by the telephone system, such as **U**, **N** or **X**, are not enclosed by the quotation marks. For scenarios where the telephone number only contains short code characters, an empty pair of quotation marks, for example ""N.

When using Voicemail Pro, names of specific call flow start points can directly access those start points via a short code. In these cases, ? is not used and # is only used if ringing is required before the start point's call flow begins.

Short codes using the Voicemail Collect feature, with either "Short Codes.name" and "#Short Codes.name" records in the Telephone Number field are automatically converted to the Voicemail Node feature and name.

 **Note:**

CallPilot voicemail is used for IP Office Branch deployments with CS 1000.

Users can access their CallPilot voicemail by dialing the Voicemail Collect short code. Access to CallPilot voicemail from Auto Attendant cannot be enabled by setting a Normal Transfer action to point to the Voicemail Collect short code. If desired, it can be enabled by setting a Normal Transfer action to point to the CallPilot number.

## Details

**Telephone Number:** ✓ See the notes above.

**Default Short Code:** ✓ \*17

**Programmable Button Control:** ✓ VMCol

**See also:** Voicemail On, Voicemail Off, Voicemail Node.

**Release:** 1.0+.

### Example: Retrieve Messages from Specific Mailbox

This short code allows a user to retrieve messages from the mailbox of the hunt group 'Sales'. This usage is not supported on Voicemail Pro running in Intuity emulation mode unless a custom call flow has been created for the hunt group, refer to the Voicemail Pro help.

**Short Code:** \*89

**Telephone Number:** "?Sales"

**Feature:** VoicemailCollect

Example: Record Message to Specific Mailbox

To allow users to deposit a message directly to Extn201's Voicemail box. This short code is useful when you know the person is not at her/his desk and you want to immediately leave a message rather than call the person and wait to be redirected to voicemail.

**Short Code:** \*201

**Telephone Number:** "#Extn201"

**Feature:** VoicemailCollect

Example: Accessing a Specific Voicemail Pro Module

This short code can be used in instances where you have a conference bridge set up on the system and a module has been created via Voicemail Pro to access this conference bridge. A short code can be created for internal access to the module. In the sample short code below, the telephone number field contains the name of the module. In this example, if a short burst of ringing is required before connecting the module, "#conferenc" would be used as the telephone number.

**Short Code:** \*100

**Telephone Number:** "conferenc"

**Feature:** VoicemailCollect

### **Example: Record Voicemail Pro Messages for Outbound Contact Express**

**Short Code:** \*99

**Telephone Number:** "edit\_messages"

**Feature:** VoicemailCollect

This short code allows users to record Voicemail Pro messages used by the Outbound Contact Express solution. For example:

- Queuing messages.
- A message intended for an answering machine.
- Messages an agent can play for a customer.
- On hold messages. (Always specify message number "0" for the hold treatment message.)
- Messages played by a Virtual Agent.

Recorded message files are stored in the folder /opt/vmpro/Wavs/Modules/CPAPrompts.

When invoked, the user is prompted to enter a number to associate with the message. The Outbound Contact Express Proactive Contact component ships with the following default English messages:

- 0: Hold message
- 1: First outbound queue message – Female
- 2: Second outbound queue message - Female
- 3: Third outbound queue message - Female
- 4: Fourth outbound queue message – Female
- 9: First outbound queue message – Male
- 10: Second outbound queue message - Male

- 11: Third outbound queue message - Male
- 12: Fourth outbound queue message - Male
- 17: Message to play to an answering machine or message to play by a virtual agent - Female
- 18: Message to play to an answering machine or message to play by a virtual agent – Male
- 19: Message played when default F6 agent key is pressed (Release the Line, completion Code 20)

#### Related links

[Short Code Features](#) on page 827

---

## Voicemail Node

Similar to Voicemail Collect but used for calls being directed to a Voicemail Pro Short Codes start point. Useful if you have set up a short code start point with Voicemail Pro and want to give direct internal access to it.

Details

**Telephone Number:** ✓ Voicemail Pro Short Code start point name without quotation marks.

**Default Short Code:** ✗

**Programmable Button Control:** ✗

**See also:** Voicemail Collect.

**Release:** 2.0+.

Example

Having created a short codes start point call flow called Sales, the following system short code can be used to route calls to that call flow:

- **Short Code:** \*96
- **Telephone Number:** Sales
- **Feature:** VoicemailNode

#### Related links

[Short Code Features](#) on page 827

---

## Voicemail On

This feature enables the user's voicemail mailbox to answer calls which ring unanswered or arrive when the user is busy.

Details

**Telephone Number:** ✘ None.

**Default Short Code:** ✔ \*18

**Programmable Button Control:** ✔ VMOOn

**See also:** Voicemail Off.

**Release:** 1.0+.

Example

This short code can be used to toggle the feature on.

**Short Code:** \*18

**Feature:** VoicemailOn

#### Related links

[Short Code Features](#) on page 827

---

## Voicemail Off

This feature disables the user's voicemail mailbox box from being used to answer calls. It does not disable the voicemail mailbox being used as the target for other functions such as call recording or messages forwarded from other mailboxes.

Details

**Telephone Number:** ✘ None.

**Default Short Code:** ✔ \*19

**Programmable Button Control:** ✔ VMOff

**See also:** Voicemail On.

**Release:** 1.0+.

Example

Below is a sample of the short code setup.

**Short Code:** \*19

**Feature:** VoicemailOff

#### Related links

[Short Code Features](#) on page 827

---

## Voicemail Ringback On

This feature enables voicemail ringback to the user's extension. Voicemail ringback is used to call the user when they have new voicemail messages. The ringback takes place each time the extension is used. This feature is useful for users who do not have voicemail light/button indicators on their telephone.

If the user has been configured to receive message waiting indication for any hunt groups, a separate voicemail ringback will occur for each such group and for the users own mailbox.

Details

**Telephone Number:** ✘

**Default Short Code:** ✔ \*48

**Programmable Button Control:** ✔ VMRB+

**See also:** Voicemail Ringback Off.

**Release:** 1.0+. For Release 3.2, the Voicemail On and Voicemail Ringback On short code features toggled. For Release 4.0 and higher, they no longer toggle.

Example

This short code can be used to turn the feature on.

**Short Code:** \*48

**Feature:** VoicemailRingbackOn

### Related links

[Short Code Features](#) on page 827

---

## Voicemail Ringback Off

This feature disables voicemail ringback to the user's extension.

Details

**Telephone Number:** ✘

**Default Short Code:** ✔ \*49

**Programmable Button Control:** ✔ VMRB-

**See also:** Voicemail Ringback On.

**Release:** 1.0+.

Example

Below is a sample of the short code setup.

**Short Code:** \*49

**Feature:** VoicemailRingbackOff

#### Related links

[Short Code Features](#) on page 827

---

## Whisper Page

This feature allows you to intrude on another user and be heard by them without being able to hear the user's existing call which is not interrupted. For example: User A is on a call with user B. When user C intrudes on user A, they can be heard by user A but not by user B who can still hear user A. Whisper page can be used to talk to a user who has enabled private call.

The ability to intrude and be intruded is controlled by two configuration settings, the Can Intrude (User | Telephony | Supervisor Settings) setting of the user intruding and the Cannot Be Intruded (User | Telephony | Supervisor Settings) setting of target being intruded on. The setting of any other internal party is ignored. By default, no users can intrude and all users are set to cannot be intruded.

The system support a range of other call intrusion methods in addition to this feature.

Details

**Telephone Number:** ✓ Target extension number.

**Default Short Code:** ✗

**Programmable Button Control:** ✓ Whisp.

**See also:** Call Intrude, Call Listen, Coaching Intrusion, Dial Inclusion.

**Release:** 8.0+.

#### Related links

[Short Code Features](#) on page 827

# Part 6: Button Programming



# Chapter 19: Button Programming Overview

This section provides an overview of system actions that can be assigned to programmable buttons on Avaya phones.

Button assignment can be done through the system configuration using Manager and for some functions using the phone itself. Using Manager, if only button programming changes are required, the configuration changes can be merged back to the system without requiring a reboot.

**Appearance Functions** The functions **Call Appearance**, **Bridged Appearance**, **Coverage** and **Line Appearance** are collectively known as "appearance functions". For full details of their operation and usage refer to the Appearance Button Operation section. The following restrictions must be observed for the correct operation of phones.

**Phone Support** Note that not all functions are supported on all phones with programmable buttons. Where possible exceptions, have been indicated. Those buttons will typically play an error tone when used on that phone. Programming of those features however is not restricted as users may hot desk between different types of phones, including some where the feature is supported.

Actions that use status feedback are only supported on buttons that provide that feedback through lamps or icons.

## Related links

- [Programming Buttons with Manager](#) on page 921
- [Programming Button via the Menu Key](#) on page 923
- [Programming Button via an Admin Button](#) on page 925
- [BST Button Programming](#) on page 927
- [T3 Self-Administration](#) on page 929
- [Interactive Button Menus](#) on page 931
- [Label Templates](#) on page 931

---

## Programming Buttons with Manager

### About this task Procedure

1. Select the  **User** required to display their configuration details.
2. Select **Button Programming**.

## Button Programming Overview

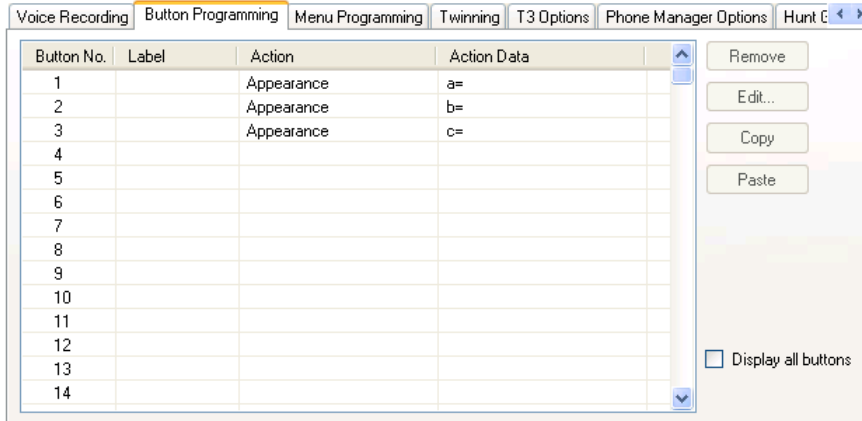

The number of button displayed is based on the phone associated with the user when the configuration was loaded. This can be overridden by selecting **Display All Buttons**. This may be necessary for users who switch between different phones using hot desking or have an expansion unit attached to their phone.

3. For the required button, either select the button and then click **Editor** double-click the button.
4. Edit the settings as required.

Use the ... button to display the menu for selecting the required button action. Select the action and set the action data, then click **OK**.

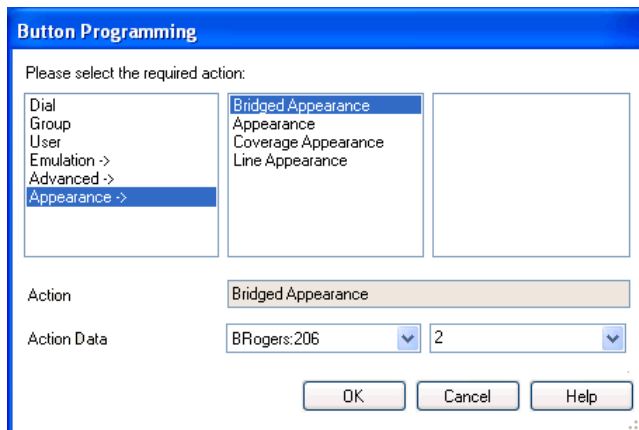

5. Click **OK**.  
Repeat for any other buttons.
6. Click **OK**.

### Result

An alternate method for the above programming is to right-click on the various fields. To do this start with the **Action** field, then **Action Data** and then **Label** if required.

### Related links

[Button Programming Overview](#) on page 921

---

## Programming Button via the Menu Key

On 4412D+, 4424D+, 4612IP, 4624IP, 6408D, 6416D, 6424D phones the **Menu**  button can be used to program some functions against other buttons. This programming also includes programmable buttons on any associated add-on units associated with the phone. Buttons already programmed as appearance buttons cannot be altered using these methods.

A Self-Administer button can also be added to allow the phone user to program the functions on their other buttons, see Self-Administer.

### Related links

[Button Programming Overview](#) on page 921

---

## Setting a Button to Dial a Number

### About this task

This process sets the selected programmable button to the Dial function in the system configuration.

### Procedure

1. With the phone idle and on-hook, press **MENU** .
2. Press **▶** and select **PROG**.
3. Enter the number required.

The left-most display button can be used to backspace and the right-most display button can be used to **Clear** the whole number.

4. Press the programmable button against which the number should be set.
5. If the button is already programmed, options to replace (**Repla**), keep (**Keep**) or delete (**Delet**) the buttons existing programming appear.

Select the option required.

6. The message **BUTTON PROGRAMMED!** indicates that the button is now programmed.

Select **Cont** and then press **Exit** .



---

## Setting a Button to a Switch Function

### About this task

This process allows users to program their own Group, User, and Park slot monitor buttons. It also allows the programming of Dial and Flash Hook buttons.

## Procedure

1. With the phone idle and on-hook, press **Menu**  twice.
2. Press **▶** and select **ProgA**.
3. Press **▶** and select **DSS**.
4. Use the **◀** and **▶** buttons to display the function required. Press the display button below the function to select it.
5. If the function requires a telephone number value set, enter the number.  
The left-most display button can be used to backspace and the right-most display button can be used to **Clear** the whole number.
6. Press the programmable button against which the number should be set.
7. If the button is already programmed, options to replace (**Repla**), keep (**Keep**) or delete (**Delet**) the buttons existing programming appear.  
Select the option required.
8. The message **BUTTON PROGRAMMED!** indicates that the button is now programmed.  
Select **Cont** and then press **Exit** .

---

## Setting Buttons to Admin Function

### About this task

Phones with a **Menu**  key can program a range of self-administer functions onto their programmable buttons. These are:

Dir - Directory.

Drop - Drop.

HFAAns - Internal Auto-Answer.

Timer - Timer.

AutCB - Automatic Callback.

Prog - Abbreviated Dial Program.

CFrwd - Call Forwarding All.

CPark - Call Park.

SAC - Send All Calls.

TmDay - Time of Day.

Admin - Self-Administer.

Acct - Account Code Entry.

AD - Abbreviated Dial.

Call Park

GrpPg - Group Paging.

CPkUp - Call Pickup.

DPkUp - Directed Call Pickup.

RngOf - Ringer Off.

Spres - AD Suppress.

HdSet - Headset Toggle.

HGNS+ - Set Hunt Group Night Service.

This is the same set of functions that can be programmed by users with a button set to Self-Administer (see Self-Administer).

### Procedure

1. With the phone idle and on-hook, press Menu .
2. Press **▶** twice and select **Admin**.
3. Use the **◀** and **▶** keys to display the function required and then select it by pressing the display button below the feature.

Selecting **Expl?** changes the display from short name mode to long name mode. In this mode the full names of the features are displayed. Select **SHORTMODE** to return to that mode.

4. If the function requires a telephone number value set, enter the number.

The left-most display button can be used to backspace and the right-most display button can be used to **Clear** the whole number.

5. Press the programmable button against which the number should be set.
6. If the button is already programmed, options to replace (**Repla**), keep (**Keep**) or delete (**Delet**) the buttons existing programming appear.

Select the option required.

7. The message **BUTTON PROGRAMMED!** indicates that the button is now programmed.

Select **Cont** and then press Exit .









---

## Programming Button via an Admin Button

The Admin (also called Self-Administer) function can be assigned to a programmable button on a user's phone. That button then allows the user to program functions against other programmable buttons on their phone, except those already set as appearance buttons.

**Admin** buttons are only supported on **2410, 2420, 4406D+, 4412D+, 4424D+, 4606IP, 4612IP, 4624IP, 5410, 5420, 6408D, 6416D** and **6424D**.

On **4412D+, 4424D+, 4612IP, 4624IP, 6408D, 6416D, 6424D** phones:

- **Admin** can be permanently accessed via **Menu** , , , **Admin**.
- **Admin1** can be permanently accessed via **Menu** , **Menu** , , **ProgA**, , , **DSS**.

#### Related links





[Button Programming Overview](#) on page 921

---

## Using an Admin Button

### About this task

#### Procedure

1. With the phone idle and on-hook, press the button programmed to **Admin** or **Admin1**.  
The list of available functions is shown.
2. Use the  and  buttons to move through the list.  
Selecting **Expi?** changes the display from short name mode to long name mode. In this mode the full names of the features are displayed. Select **SHORTMODE** to return to that mode.
3. Select the function required.
4. If the function requires a telephone number value set, enter the number.  
The left-most display button can be used to backspace and the right-most display button can be used to Clear the whole number.
5. Press the programmable button against which the number should be set.  
On phones with multiple pages of buttons use the  and  button to select the required page before pressing the button to program.
6. If the button is already programmed, options to replace, keep or delete the button's existing programming appear.  
Select the option required.
7. The message **BUTTON PROGRAMMED!** indicates that the button is now programmed.
8. Select **Cont.** and then press **Exit** or lift the handset to go off-hook.

---

# BST Button Programming

## About this task

The process below can be used to assign functions to programmable buttons on T-Series and M-Series phones. Existing button can be overwritten except buttons set to appearance functions.

## Procedure

1. Press `Feature *3`.

If a security code is requested, enter your phone login code and press #.

2. Use one of the processes below.

Press \* to switch between processes (or **More** if displayed). On T7000 phones, only the first process is supported.

3. Select Button and then Function

- a. Press the button to program.
- b. Enter the feature code of the function required (the only \* function supported is \*7 for contrast).
- c. If the button has an existing function it is displayed and the option to replace the button or return to function selection.

4. Select Function and then Button.

Enter the number for the feature required or use the volume buttons to move through the list of functions.

01. Speed dial
02. Ring Again
03. Conference
04. Call Forward All
05. Last Number Redial
06. Page Group
07. Voicemail
08. Automatic Intercom
09. Priority Call
10. Transfer
11. Call Park
12. Group Pickup
13. Direct Pickup
14. Timer

15. Do Not Disturb On
16. Contrast
17. Group Listen On
18. Time of Day
17. Call Log
18. Self-Administer
19. Account Code
20. Forward on Busy
21. Forward on No Answer
22. Pickup
23. Directory
24. Flash Hook
25. Internal Auto Answer
26. Set Hunt Group Night Service
27. Twinning
28. Ringer Off

- a. Press **Hold** to select a currently displayed function.
- b. Press the button to which the function should be assigned.
- c. If the button has an existing function it is displayed and the option to replace the button or return to function selection.

5. When **Default Buttons** is displayed, press **Hold** (or the **Prog** softkey if displayed).

The phone buttons are defaulted to those appropriate to the phone type. Note that only buttons that have a default function on the phone type are defaulted. It does not affect the functions assigned to any buttons that do not have default functions.

### Default Buttons

For T-Series and M-Series phones, default button functions are assigned to buttons when a phone is first connected to the extension port. The functions assigned depend on the particular phone model.

The default functions for the phone model are also assigned when **Feature \*3** is used to default the phone's buttons. Buttons without a default function are not overwritten when the buttons are defaulted.

### Related links

[Button Programming Overview](#) on page 921



## T3 Self-Administration

**\* Note:**

IP Office R11 does not support T3 and T3 IP Phones.

Release 4.2+ supports functions for T3 phone users to be able to program their own buttons. This is similar to the existing Self-Administer button supported on other phones but is configured and accessed via different methods.

The user accesses button programming through **Menu | Settings | Button programming**. This function is not available by default, instead it must be configured as available for the user using the method detailed below.

Once enabled, the user is able to configure the following functions on buttons:

Function	Description
<b>empty</b>	Returns the button to its normal default function.
<b>Account Code</b>	Allows the user to enter an account code before or during a call. The account code can be preset or entered after the button press. See the Account Code Entry function.
<b>Callback</b>	Set a callback from the currently dialed extension number. See the Automatic Callback function.
<b>Call list</b>	Displays a list of calls received. See the Call List function.
<b>Call Tracing</b>	Activate malicious call tracing. See the MCID Activate function and Malicious Call Tracing (MCID).
<b>Dial</b>	Dial a preset number or partial number that can be completed after the button press. See the Dial function.
<b>Dial Intercom</b>	Make a page call to the selected target if it supports handsfree answer. See Dial Intercom.
<b>Directory</b>	Display the system directory. See the Directory function.
<b>Do not disturb</b>	Toggle the phone between do not disturb on and off. See the Send All Calls function.
<b>Follow me here</b>	Activate/cancel follow me here. See the Follow Me Here function.
<b>Forward unconditional</b>	Activate/cancel forward all calls. See the Forward Unconditional On function.
<b>Group Paging</b>	Page a group of phones. See the Group Paging function.
<b>Group Membership</b>	Enable/disable the user membership of a group or all groups. See the Hunt Group Enable function.

*Table continues...*

<b>Group State</b>	Change a hunt group's out of service status. See the Set Hunt Group Out of Service function.
<b>Headset</b>	Switch between handset and headset modes. See the Headset Toggle function.
<b>Internal Auto-Answer</b>	Auto connect internal calls after a single tone. See the Internal Auto-answer function.
<b>Login</b>	Access the menu for phone log in. See the Extn Login function.
<b>Logout</b>	Log out from the phone. See the Extn Logout function.
<b>Night Service</b>	Change a hunt group's night service status. See the Set Hunt Group Night Service function.
<b>Paging</b>	Page an extension or group. See the Dial Paging function.
<b>Pickup</b>	Answer a call alerting on the system. See the Call Pickup function.
<b>Pickup Member</b>	Answer a call alerting the hunt group of which the user is a member. See the Call Pickup Members function.
<b>Twinning</b>	Switch mobile twinning on/off and set the twinning destination. Also used to pull a call answered at the twinned number back to the users primary extension. See the Twinning function.
<b>User</b>	Monitor the status of a user. Also used to call them or to pickup calls alerting them. See the User function.
<b>Visual Voice</b>	Create a visual voice access button. See Visual Voice.
<b>Voicemail</b>	Equivalent to the Voicemail Collect function.
<b>Voicemail on/off</b>	Switch the use of the user's mailbox to answer unanswered calls on/off. See the Voicemail On function.

The user will need to be made aware of which physical buttons can be programmed as this varies between the different T3 phones. See T3 Compact, T3 Classic and T3 Comfort.

### Configuring a T3 User for Button Programming

1. Using Manager, receive the configuration from the system.
2. Select the T3 user and then select **Menu Programming**.
3. Set the action for one of the menus to **Self-Administer**.
4. Send the configuration back to the system.
5. The user will now be able to access button programming from their phone via **Menu | Settings | Button programming**.

**Related links**

[Button Programming Overview](#) on page 921

---

## Interactive Button Menus

For certain functions, on display phones where a button has been configured without a specific number, a menu for number entry is displayed. The menu includes a **Dir** option for selecting a number from the directories held by the system.

Functions that use the interactive menu are:

Feature	Directory lists...	Feature	Directory lists...
Automatic Intercom	Users	Follow Me Here Cancel	Users
Acquire Call/Call Steal	Users	Follow Me Here	Users
Call Forwarding All	Users	Follow Me To	Users
Call Intrude	Users	Forward Number	Users/Groups
Call Park To Other Extension	Users	Forward Busy Number	Users/Groups
Dial Inclusion	Users	Group Paging	Users/Groups
Dial Intercom	Users	Leave Word Calling	Users/Groups
Directed Call Pickup	Users/Groups	Priority Calling	Users/Groups

User and Group buttons can be used to indicate the required user or hunt group only if those buttons are on an associated button module. **User** and **Group** buttons on the users extension are not accessible while the interactive button menu is being displayed.

For functions supported across a multi-site network, the directory will include remote users and advertised hunt groups.

For M-Series and T-Series phone, the volume buttons are used to scroll through the list of matching names. If this is done during a call or while a call is alerting, this will also adjust the call or ring volume.

**Related links**

[Button Programming Overview](#) on page 921

---

## Label Templates

A zip file is available containing Word document templates for the paper programmable key labels used on various phones supported by the system. Two templates are provided, one for A4 size paper, the other for US Letter sized paper. See <http://marketingtools.avaya.com/knowledgebase/ipoffice/dsstemplates/index.htm>

## Button Programming Overview

For ETR, M-Series, T-Series, 1400 and 1600 phones, a number of tools and perforated printable labels are available. For further details visit <http://support.avaya.com> and search for information on DESI. Alternatively, visit <http://www.desi.com>.

Manager is able to pass user button information to a DESI application on the same PC. This allows printing of labels using the label text set within the system configuration. Currently only ETR, M-Series, T-Series, 1400 and 1600 phones are supported by DESI.

### Related links

[Button Programming Overview](#) on page 921

# Chapter 20: Button Programming Actions

The following sections provide details for each of the button actions supported by system. Note that this does not include buttons on phones on a system running in Partner Edition mode.

For each the following details are listed:

- **Action** Indicates the selection path to the action from within the list of actions displayed in Manager.
- **Action Data** Indicates the type of data required by the action. For some actions no data is required while for others action data may be optional. The option to enter the data after pressing the button is not available for all phones, see Interactive Button Menus.
- **Default Label** This is the default text label displayed on phones which provide a display area next to programmable buttons. Alternate labels can be specified in the system configuration or entered by the phone user (refer to the telephone user guide). Note that for buttons with action data set, the action data may also be displayed as part of the default label. Depending on the display capacity of the particular phone, either a short or long label is displayed.
- **Toggles** Indicates whether the action toggles between two states, typically on or off.
- **Status Indication** Indicates whether the button provides status indication relevant to the feature if the button has status lamps or display. If the **Status Indication** is listed as **Required** it indicates that the button action is only supported on programmable buttons that can provide status indication.
- **User Admin** This item indicates that users with a Self-Administer button can assign the action to other buttons themselves.
- **Phone Support** This is only a general indication of support or otherwise of an action by phones within particular series. On phones with 3 or less programmable buttons those button can only be used for the Call Appearance action. In addition some actions are only supported on phones where the programmable buttons provide status indication and or a display for data entry once the feature is invoked.

## Table of Button Programming Actions

The following tables list the actions available for programmable buttons on system.

 **Login Code Required** Some function may require the user to enter their log in code. This typically applies when the action data is left blank for entry when the button is pressed.

### General

Action	Action Data	Default Label
Dial	Any number.	Dial
Group	"Group name" in quote marks.	<Group name>
User	"User name" in quote marks.	<User name>

### Appearance

Action	Action Data	Default Label
Appearance	None.	<b>a=</b>
Bridged Appearance	User name and call appearance button number.	<user name><appearance label>
Coverage Appearance	User name.	<user name>
Line Appearance	Line appearance ID.	<b>Line</b>

### Emulation

Action	Action Data	Short Label	Long Label
Abbreviated Dial	Any number.	<b>AD</b>	<b>Abbreviate Dial</b>
Abbreviated Dial Pause	None.	<b>Pause</b>	–
Abbreviated Dial Program	None.	<b>Prog</b>	–
Abbreviated Dial Stop	None.	<b>Stop</b>	–
Absent Message	None.	None.	None.
Account Code Entry	Account code or blank for entry when pressed.	<b>Acct</b>	<b>Account Code</b>
ACD Agent Statistics	None.	<b>Stats</b>	–
ACD Stroke Count	None.	<b>Count</b>	–
AD Special Function Mark	None.	<b>Mark</b>	–
AD Special Function Wait	None.	<b>Wait</b>	–
AD Special Functions	None.	<b>Sfunc</b>	–
AD Suppress	None.	<b>Spres</b>	<b>Suppress Digits</b>
Automatic Callback	None.	<b>AutCB</b>	<b>Auto Callback</b>
Automatic Intercom	User number or name.	<b>lauto</b>	<b>Auto Intercom</b>
Call Forwarding All 	Any number or blank for entry when pressed.	<b>CFrwd</b>	<b>Call Forward All</b>
Call Park	Park slot ID (alphanumeric) or blank for menu of slots in use.	<b>CPark</b>	<b>Call Park</b>

*Table continues...*

Action	Action Data	Short Label	Long Label
Call Park To Other Extension	User number.	<b>RPark</b>	<b>Call Park to Other</b>
Call Pickup	None.	<b>CpkUp</b>	<b>Call Pickup Any</b>
Cancel Leave Word Calling	None.	<b>CnLWC</b>	–
Consult	None.	<b>Cnslt</b>	–
Dial Intercom	User number or name or blank for entry when pressed.	<b>Idial</b>	<b>Auto Intercom</b>
Directed Call Pickup	User number or name or group number or name or or blank for entry when pressed..	<b>DpkUp</b>	<b>Call Pickup</b>
Directory	None.	<b>Dir</b>	–
Drop	None.	<b>Drop</b>	<b>Drop Call</b>
Emergency View	None.	<b>911–View or EView</b>	
Group Paging	User or group number or name or blank for entry when pressed.	<b>GrpPg</b>	<b>Page</b>
Headset Toggle	None or FF	<b>HdSet</b>	–
Inspect	None.	<b>Inspt</b>	–
Internal Auto-Answer	None.	<b>HFAns</b>	<b>Auto Answer</b>
Leave Word Calling	None.	<b>LWC</b>	–
Manual Exclude	None.	<b>Excl</b>	–
Priority Calling	None.	<b>Pcall</b>	–
Ringer Off	None.	<b>RngOf</b>	<b>Ringer Off</b>
Self-Administer 	Blank or 1 or 2	<b>Admin</b>	<b>Self Administer</b>
Send All Calls	None.	<b>SAC</b>	<b>Send All Calls</b>
Stored Number View	None.	<b>BtnVu</b>	–
Time of Day	None.	<b>TmDay</b>	–
Timer	None.	<b>Timer</b>	–
Twinning	None.	<b>Twinning</b>	<b>Twinning</b>
Visual Voice	None.	<b>Voice</b>	<b>Voice</b>

**Advanced**

Action	Action Data	Category	Short Label	Long Label
Acquire Call	User number or blank for last call transferred.	Call	Acquir	Acquire
Break Out	System name or IP address or blank for selection when pressed.	Dial	BkOut	Breakout
Busy	None.	Busy	Busy	–
Busy On Held	0 (off) or 1 (on).	Busy	BusyH	–
Call Intrude	User number or blank for entry when pressed.	Call	Intru	Call Intrude
Call List	None.	Call	LIST	–
Call Listen	User number.	Call	Listn	Listen
Call Log	None.	Call		Call Log
Call Pickup Any	None.	Call	PickA	Pickup Any
Call Pickup Group	Group number or name.	Call	PickG	Pickup Group
Call Pickup Members	Group number or name.	Call	PickM	Pickup Members
Call Queue	User number.	Call	Queue	Queue
Call Record	None.	Call	Recor	Record
Call Screening	None.	Call	CallScreen	Call Screening
Call Steal	User number or blank for last call transferred.	Call	Steal	–
Call Waiting Off	None.	Call	CWOff	–
Call Waiting On	None.	Call	CWOn	–
Call Waiting Suspend	None.	Call	CWSus	–
Cancel All Forwarding	None.	Call	FwdOf	Call Forward Off
Cancel Ring Back When Free	None.	Miscellaneous	RBak-	–
Channel Monitor	Channel number.	Call	ChMon	–
Clear Call	None.	Call	Clear	Clear
Clear CW	None.	Call	ClrCW	–

*Table continues...*



Action	Action Data	Category	Short Label	Long Label
Clear Hunt Group Night Service	Group number.	Call	HGNS-	-
Clear Hunt Group Out Of Service	Group number.	Call	HNOS-	-
Clear Quota	"Service name" within quote marks or "" for all services.	Call	Quota	-
Coaching Intrusion	User number or name or blank for entry when pressed.	Call	Coach	Coaching Intrusion
Conference	Invoke the conference process. (M and T-Series phones only)	Call	Conf	-
Conference Add	None.	Call	Conf+	Conference Add
Conference Meet Me	Conference name or number.	Call	CnfMM	Conf. Meet Me
Dial 3K1	Any number.	Dial	D3K1	Dial 3K1
Dial 56K	Any number.	Dial	D56K	Dial 56K
Dial 64K	Any number.	Dial	D64K	Dial 64K
Dial CW	User number.	Dial	DCW	Dial Call Waiting
Dial Direct	User number or name or blank for entry when pressed.	Dial	Dirct	Auto Intercom
Dial Emergency	Any number.	Dial	Emrgy	Dial Emergency
Dial Inclusion	User number or name or blank for entry when pressed.	Dial	Inclu	Dial Inclusion
Dial Paging	User or group number or name or blank for entry when pressed.	Dial	Page	Page
Dial Physical Extn by Number	Extension port Base Extension number.	Dial	PhyEx	Dial Physical Extn
Dial Physical Extn by Id	Extension port ID number. (Release 1.4+)	Dial	DialP	Dial Extn by Id
Dial Speech	Any number.	Dial	DSpch	Dial Speech

*Table continues...*

Button Programming Actions

Action	Action Data	Category	Short Label	Long Label
Dial V110	Any number.	Dial	DV110	Dial V110
Dial V120	Any number.	Dial	DV120	Dial V120
Dial Video	Any number.	Dial	Dvide	Dial Video
Display Msg	Command string.	Dial	Displ	–
Do Not Disturb Auto-Intercom Deny	None	Do Not Disturb	NoAI	No Auto Int Calls
Do Not Disturb Exception Add	Any number.	Do Not Disturb	DNDX+	–
Do Not Disturb Exception Delete	Any number.	Do Not Disturb	DNDX-	–
Do Not Disturb Off	None.	Do Not Disturb	DNDOf	–
Do Not Disturb On	None.	Do Not Disturb	DNDOn	Do Not Disturb
Extn Login	None.	Extension	Login	Login
Extn Logout	None.	Extension	Logof	Logout
Flash Hook	None.	Miscellaneous	Flash	Flash Hook
Follow Me Here 🗑️	User number.	Follow Me	Here+	Follow Me Here
Follow Me Here Cancel	User number or blank for entry when pressed.	Follow Me	Here-	Follow Me Here-
Follow Me To 🗑️	User name or user number or blank for entry when pressed.	Follow Me	FoITo	Follow Me To
Forward Hunt Group Calls On	None.	Forward	FwdH+	–
Forward Hunt Group Calls Off	None.	Forward	FwdH-	Fwd HG Calls
Forward Number 🗑️	Any number or blank for entry when pressed.	Forward	FwdNo	Fwd Number
Forward On Busy Number 🗑️	Any number or blank for entry when pressed.	Forward	FwBNo	Fwd Busy Number
Forward On Busy Off	None.	Forward	FwBOf	–
Forward On Busy On	None.	Forward	FwBOn	Fwd Busy
Forward On No Answer Off	None.	Forward	FwNOF	–

Table continues...

Action	Action Data	Category	Short Label	Long Label
Forward On No Answer On	None.	Forward	<b>FwNOn</b>	<b>Fwd No Answer</b>
Forward Unconditional Off	None.	Forward	<b>FwUOf</b>	–
Forward Unconditional On	None.	Forward	<b>FwUOn</b>	<b>Fwd Unconditional</b>
Group Listen On	None.	Extension	<b>GroupListenOn</b>	–
Hold Call	ISDN Exchange slot number.	Hold	<b>Hold</b>	–
Hold CW	None.	Hold	<b>HoldCW</b>	–
Hold Music	None.	Hold	<b>Music</b>	<b>Hold Music</b>
Hunt Group Disable	Group number or name or blank for all groups.	Hunt Group	<b>HGDis</b>	
Hunt Group Enable	Group number or name or blank for all groups.	Hunt Group	<b>HGEna</b>	<b>HG Enable</b>
Last Number Redial	Redial the last number dialed. (M and T-Series phones only)	Call	<b>Again</b>	–
MCID Activate	None.	Miscellaneous	<b>MCID</b>	<b>Malicious Call</b>
Monitor Analogue Trunk MWI	Line appearance ID.	Voicemail	<b>TrkMW</b>	<b>Trunk MWI</b>
Off Hook Station	None.	Miscellaneous	<b>OHStn</b>	–
Pause Recording	None.	Call	<b>PauseRec</b>	<b>Pause Recording</b>
Priority Call	User number or name.	Call	<b>PCall</b>	<b>Priority Call</b>
Private Call	None. (Release 4.0+)	Call	<b>PrivC</b>	<b>Private Call</b>
Relay Off	1 or 2.	Relay	<b>Rely-</b>	–
Relay On	1 or 2.	Relay	<b>Rely+</b>	<b>Relay On</b>
Relay Pulse	1 or 2.	Relay	<b>Relay</b>	<b>Relay Pulse</b>
Resume Call	ISDN Exchange slot number.	Call	<b>Resum</b>	–
Retrieve Call	ISDN Exchange slot number.	Call	<b>Retriv</b>	–
Ring Back When Free	None.	Miscellaneous	<b>RBak+</b>	<b>Auto Callback</b>

*Table continues...*

## Button Programming Actions

Action	Action Data	Category	Short Label	Long Label
Set Absent Text	String for selected message and custom text.	Set	<b>Absnt</b>	<b>Absence Text</b>
Set Account Code	Blank or valid account code. (Release 2.1+)	Set	<b>Acct</b>	<b>Account Code</b>
Set Hunt Group Night Service	Group number.	Set	<b>HGNS+</b>	<b>HG Night Service</b>
Set Hunt Group Out Of Service	Group number.	Set	<b>HGOS+</b>	<b>HG Out of Service</b>
Set Inside Call Seq	Value 0 to 10.	Set	<b>ICSeq</b>	–
Set Night Service Group	Group number. (Release 4.2+)	Set	<b>SetNSG</b>	<b>HG NS Group</b>
Set No Answer Time	Time in seconds (range 6 to 99999).	Set	<b>NATim</b>	<b>No Answer Time</b>
Set Outside Call Seq	Value 0 to 10.	Set	<b>OCSeq</b>	–
Set Out of Service Group	Group number. (Release 4.2+)	Set	<b>SetOOSG</b>	<b>HG OS Group</b>
Set Ringback Seq	Value 0 to 10.	Set	<b>RBSeq</b>	–
Set Wrap Up Time	Time in seconds (range 0 to 99999).	Set	<b>WUTim</b>	<b>Wrap-up Time</b>
Speed Dial	Initiate the speed dial selection process. (M and T-Series phones only)	Dial	<b>SpdDial</b>	–
Stamp Log	None.	Miscellaneous	<b>StmpL</b>	<b>Stamp Log</b>
Suspend Call	ISDN Exchange slot number.	Suspend	<b>Suspe</b>	–
Suspend CW	ISDN Exchange slot number.	Suspend	<b>SusCW</b>	–
Toggle Calls	None.	Call	<b>Toggl</b>	–
Transfer	Initiate the call transfer process. (M and T-Series phones only)	Call	<b>Xfer</b>	–
Unpark Call	Park slot ID (alphanumeric).	Call	<b>Ride</b>	–
Voicemail Collect	See notes.	Voicemail	<b>VMCol</b>	<b>VMail Collect</b>
Voicemail Off	None.	Voicemail	<b>VMOff</b>	–

*Table continues...*

Action	Action Data	Category	Short Label	Long Label
Voicemail On	None.	Voicemail	<b>VMon</b>	<b>VMail On</b>
Voicemail Ringback Off	None.	Voicemail	<b>VMRB-</b>	-
Voicemail Ringback On	None.	Voicemail	<b>VMRB+</b>	<b>VMail Ringback</b>
Whisper Page	User number or name or blank for entry when pressed.	Call	<b>Whisp</b>	<b>Whisper Page</b>
Channel Monitor	Channel	Call	<b>ChMon</b>	-

---

## 911-View

See [Emergency View](#) on page 1006.

---

## Abbreviated Dial

This function allows quick dialing of a stored number.

**Action:** Emulation | Abbreviated Dial.

**Action Data:**

- **Full Number** The number is dialled.
- **Partial Number** The partial number is dialled and the user can then complete dialing the full number.

**Default Label:** AD or Abbreviate Dial.

**Toggles:** No.

**Status Indication:** No.

**User Admin:** Yes.

**Phone Support** Note that support for particular phone models is also dependant on the system software level.

<b>Analog:</b> No	<b>20 Series:</b> Yes	<b>4100 Series:</b> No	<b>6400 Series:</b> Yes	<b>D100:</b> No
<b>1100 Series:</b> No	<b>2400 Series:</b> Yes [1]	<b>4400 Series:</b> Yes	<b>7400 Series:</b> No	<b>M-Series:</b> Yes

*Table continues...*

<b>1200 Series:</b> No	<b>3600 Series:</b> Yes	<b>4600 Series:</b> Yes [1]	<b>9040:</b> Yes	<b>T-Series:</b> Yes
<b>1400 Series:</b> Yes [1]	<b>3700 Series:</b> No	<b>5400 Series:</b> Yes [1]	<b>9500 Series:</b> Yes	
<b>1600 Series:</b> Yes [1]	<b>3810:</b> No	<b>5600 Series:</b> Yes [1]	<b>9600:</b> No	

[1] Not 1403, 1603, 2402, 4601, 4602, 5402, 5601 and 5602 models.

---

## Abbreviated Dial Pause

Not supported. Provided for CTI emulation only. Allows a user to enter a pause character when programming an abbreviated dial.

**Action:** Emulation | Abbreviated Dial Pause.

**Action Data:** None.

**Default Label:** Pause.

**Toggles:** No.

**Status Indication:** No.

**User Admin:** No.

**Phone Support** Note that support for particular phone models is also dependant on the system software level.

<b>Analog:</b> No	<b>20 Series:</b> Yes	<b>4100 Series:</b> No	<b>6400 Series:</b> Yes	<b>D100:</b> No
<b>1100 Series:</b> No	<b>2400 Series:</b> Yes [1]	<b>4400 Series:</b> Yes	<b>7400 Series:</b> No	<b>M-Series:</b> No
<b>1200 Series:</b> No	<b>3600 Series:</b> No	<b>4600 Series:</b> Yes [1]	<b>9040:</b> Yes	<b>T-Series:</b> No
<b>1400 Series:</b> Yes [1]	<b>3700 Series:</b> No	<b>5400 Series:</b> Yes	<b>9500 Series:</b> No	<b>T3/T3 IP Series:</b> [2]
<b>1600 Series:</b> Yes [1]	<b>3810:</b> Yes	<b>5600 Series:</b> Yes [1]	<b>9600 Series:</b> No	

1. Not 1403, 1603, 2402, 4601, 4602, 5601 and 5602 except where 4602 is supported on Release 2.1 and 3.0DT software.
2. May have limited support on some specific T3 phone models if detailed below.

---

## Abbreviated Dial Program

Not supported. Provided for CTI emulation only. Allows a user to program abbreviated dialing numbers against other programmable buttons. This function cannot be used to overwrite call appearance buttons.

**Action:** Emulation | Abbreviated Dial Program.

**Action Data:** None.

**Default Label:** Prog.

**Toggles:** No.

**Status Indication:** No.

**User Admin:** Yes.

**Phone Support** Note that support for particular phone models is also dependant on the system software level.

<b>Analog:</b> No	<b>20 Series</b>	<b>4100 Series:</b> No	<b>6400 Series:</b> No	<b>D100:</b> No
<b>1100 Series:</b> No	<b>2400 Series:</b> No	<b>4400 Series:</b> No	<b>7400 Series:</b> No	<b>M-Series:</b> No
<b>1200 Series:</b> No	<b>3600 Series:</b> No	<b>4600 Series:</b> No	<b>9040:</b> No	<b>T-Series:</b> No
<b>1400 Series:</b> No	<b>3700 Series:</b> No	<b>5400 Series:</b> No	<b>9500 Series:</b> No	
<b>1600 Series:</b> No	<b>3810:</b> No	<b>5600 Series:</b> No	<b>9600 Series:</b> No	

---

## Abbreviated Dial Stop

Not supported. Provided for CTI emulation only. Allows a user to enter a stop character when programming an abbreviated dial.

**Action:** Emulation | Abbreviated Dial Stop.

**Action Data:** None.

**Default Label:** Stop.

**Toggles:** No.

**Status Indication:** No.

**User Admin:** No.

**Phone Support** Note that support for particular phone models is also dependant on the system software level.

<b>Analog:</b> No	<b>20 Series:</b> Yes	<b>4100 Series:</b> No	<b>6400 Series:</b> Yes	<b>D100:</b> No
-------------------	-----------------------	------------------------	-------------------------	-----------------

*Table continues...*

<b>1100 Series:</b> No	<b>2400 Series:</b> Yes [1]	<b>4400 Series:</b> Yes	<b>7400 Series:</b> No	<b>M-Series:</b> No
<b>1200 Series:</b> No	<b>3600 Series:</b> No	<b>4600 Series:</b> Yes [1]	<b>9040:</b> Yes	<b>T-Series:</b> No
<b>1400 Series:</b> Yes [1]	<b>3700 Series:</b> No	<b>5400 Series:</b> Yes	<b>9500 Series:</b> No	
<b>1600 Series:</b> Yes [1]	<b>3810:</b> Yes	<b>5600 Series:</b> Yes [1]	<b>9600 Series:</b> No	

1. Not 1403, 1603, 2402, 4601, 4602, 5601 and 5602 except where 4602 is supported on Release 2.1 and 3.0DT software.

## Absent Message

This feature allows to select the user's current absence text. See [Set Absent Text](#) on page 1050.

## Account Code Entry

Enter an account code for a call. This button can be used before dialing a number or during a call.

**Action:** Emulation | Account Code Entry.

**Action Data:** Optional. If an code is set it must match an account code set in the account codes list. If no account code is set, the phone display will request entry of a valid code. This option is not supported on XX02 phones and the T7000 phone.

**Default Label:** Acct or Account Code.

**Toggles:** No.

**Status Indication:** No.

**User Admin:** Yes.

**Phone Support** Note that support for particular phone models is also dependant on the system software level.

<b>Analog:</b> No	<b>20 Series:</b> Yes	<b>4100 Series:</b> No	<b>6400 Series:</b> Yes	<b>D100:</b> Yes
<b>1100 Series:</b> Yes	<b>2400 Series:</b> Yes [1]	<b>4400 Series:</b> Yes	<b>7400 Series:</b> No	<b>M-Series:</b> Yes
<b>1200 Series:</b> Yes	<b>3600 Series:</b> No	<b>4600 Series:</b> Yes [1]	<b>9040:</b> Yes	<b>T-Series:</b> Yes

*Table continues...*



<b>1400 Series:</b> Yes [1]	<b>3700 Series:</b> No	<b>5400 Series:</b> Yes	<b>9500 Series:</b> Yes	
<b>1600 Series:</b> Yes [1]	<b>3810:</b> Yes	<b>5600 Series:</b> Yes [1]	<b>9600 Series:</b> Yes	

1. Not 1403, 1603, 4601, 4602, 5601 and 5602 except where 4602 is supported on Release 2.1 and 3.0 DT software.

---

## ACD Agent Statistics

Not supported. Provided for CTI emulation only.

**Action:** Emulation | ACD Agent Statistics.

**Action Data:** None.

**Default Label:** Stats.

**Toggles:** No.

**Status Indication:** No.

**User Admin:** No.

**Phone Support** Note that support for particular phone models is also dependant on the system software level.

<b>Analog:</b> No	<b>20 Series:</b> Yes	<b>4100 Series:</b> No	<b>6400 Series:</b> Yes	<b>D100:</b> No
<b>1100 Series:</b> No	<b>2400 Series:</b> Yes [1]	<b>4400 Series:</b> Yes	<b>7400 Series:</b> No	<b>M-Series:</b> No
<b>1200 Series:</b> No	<b>3600 Series:</b> No	<b>4600 Series:</b> Yes [1]	<b>9040:</b> Yes	<b>T-Series:</b> No
<b>1400 Series:</b> Yes [1]	<b>3700 Series:</b> No	<b>5400 Series:</b> Yes	<b>9500 Series:</b> No	
<b>1600 Series:</b> Yes [1]	<b>3810:</b> Yes	<b>5600 Series:</b> Yes [1]	<b>9600 Series:</b> No	

1. Not 1403, 1603, 2402, 4601, 4602, 5601 and 5602 except where 4602 is supported on Release 2.1 and 3.0DT software.

---

## ACD Stroke Count

Not supported. Provided for CTI emulation only.

**Action:** Emulation | ACD Stroke Count.

**Action Data:** None.

**Default Label:** Count.

**Toggles:** No.

**Status Indication:** No.

**User Admin:** Yes.

**Phone Support** Note that support for particular phone models is also dependant on the system software level.

<b>Analog:</b> No	<b>20 Series:</b> Yes	<b>4100 Series:</b> No	<b>6400 Series:</b> Yes	<b>D100:</b> No
<b>1100 Series:</b> No	<b>2400 Series:</b> Yes [1]	<b>4400 Series:</b> Yes	<b>7400 Series:</b> No	<b>M-Series:</b> No
<b>1200 Series:</b> No	<b>3600 Series:</b> No	<b>4600 Series:</b> Yes [1]	<b>9040:</b> Yes	<b>T-Series:</b> No
<b>1400 Series:</b> Yes [1]	<b>3700 Series:</b> No	<b>5400 Series:</b> Yes	<b>9500 Series:</b> No	
<b>1600 Series:</b> Yes [1]	<b>3810:</b> Yes	<b>5600 Series:</b> Yes [1]	<b>9600 Series:</b> No	

1. Not 1403, 1603, 2402, 4601, 4602, 5601 and 5602 except where 4602 is supported on Release 2.1 and 3.0 DT software.

## Acquire Call

See Call Steal.

## AD Special Functions

Not supported. Provided for CTI emulation only. Allows a user to enter a special character (mark, pause suppress, wait) when entering an abbreviated dial.

**Action:** Emulation | AD Special Functions.

**Action Data:** None.

**Default Label:** Sfunc.

**Toggles:** No.

**Status Indication:** No.

User Admin: No.

**Phone Support** Note that support for particular phone models is also dependant on the system software level.

<b>Analog:</b> No	<b>20 Series:</b> Yes	<b>4100 Series:</b> No	<b>6400 Series:</b> Yes	<b>D100:</b> No
<b>1100 Series:</b> No	<b>2400 Series:</b> Yes [1]	<b>4400 Series:</b> Yes	<b>7400 Series:</b> No	<b>M-Series:</b> No
<b>1200 Series:</b> No	<b>3600 Series:</b> No	<b>4600 Series:</b> Yes [1]	<b>9040:</b> Yes	<b>T-Series:</b> No
<b>1400 Series:</b> Yes [1]	<b>3700 Series:</b> No	<b>5400 Series:</b> Yes	<b>9500 Series:</b> No	
<b>1600 Series:</b> Yes [1]	<b>3810:</b> Yes	<b>5600 Series:</b> Yes [1]	<b>9600 Series:</b> No	

1. Not 1403, 1603, 2402, 4601, 4602, 5601 and 5602 except where 4602 is supported on Release 2.1 and 3.0DT software.

---

## AD Special Function Mark

Not supported. Provided for CTI emulation only. Allows a user to enter a mark character when programming abbreviated dial.

**Action:** Emulation | AD Special Function Mark.

**Action Data:** None.

**Default Label:** Mark.

**Toggles:** No.

**Status Indication:** No.

User Admin: No.

**Phone Support** Note that support for particular phone models is also dependant on the system software level.

<b>Analog:</b> No	<b>20 Series:</b> Yes	<b>4100 Series:</b> No	<b>6400 Series:</b> Yes	<b>D100:</b> No
<b>1100 Series:</b> No	<b>2400 Series:</b> Yes [1]	<b>4400 Series:</b> Yes	<b>7400 Series:</b> No	<b>M-Series:</b> No
<b>1200 Series:</b> No	<b>3600 Series:</b> No	<b>4600 Series:</b> Yes [1]	<b>9040:</b> Yes	<b>T-Series:</b> No
<b>1400 Series:</b> Yes [1]	<b>3700 Series:</b> No	<b>5400 Series:</b> Yes	<b>9500 Series:</b> No	

*Table continues...*

<b>1600 Series:</b> Yes [1]	<b>3810:</b> Yes	<b>5600 Series:</b> Yes [1]	<b>9600 Series:</b> No	
--------------------------------	------------------	--------------------------------	------------------------	--

1. Not 1403, 1603, 2402, 4601, 4602, 5601 and 5602 except where 4602 is supported on Release 2.1 and 3.0DT software.

## AD Special Function Wait

Not supported. Provided for CTI emulation only. Allows a user to enter a Wait for Dial Tone character when programming an abbreviated dial.

**Action:** Emulation | AD Special Function Wait.

**Action Data:** None.

**Default Label:** Wait.

**Toggles:** No.

**Status Indication:** No.

User Admin: No.

**Phone Support** Note that support for particular phone models is also dependant on the system software level.

<b>Analog:</b> No	<b>20 Series:</b> Yes	<b>4100 Series:</b> No	<b>6400 Series:</b> Yes	<b>D100:</b> No
<b>1100 Series:</b> No	<b>2400 Series:</b> Yes [1]	<b>4400 Series:</b> Yes	<b>7400 Series:</b> No	<b>M-Series:</b> No
<b>1200 Series:</b> No	<b>3600 Series:</b> No	<b>4600 Series:</b> Yes [1]	<b>9040:</b> Yes	
<b>1400 Series:</b> Yes [1]	<b>3700 Series:</b> No	<b>5400 Series:</b> Yes	<b>9500 Series:</b> No	
<b>1600 Series:</b> Yes [1]	<b>3810:</b> Yes	<b>5600 Series:</b> Yes [1]	<b>9600 Series:</b> No	

No

1. Not 1403, 1603, 2402, 4601, 4602, 5601 and 5602 except where 4602 is supported on Release 2.1 and 3.0DT software.

## AD Suppress

Suppresses the display of dialed digits on the telephone display. Dialed digits are replaced with an s character.



**Action:** Emulation | AD Suppress.

**Action Data:** None.

**Default Label:** Spres or Suppress Digits.

**Toggles:** Yes.

**Status Indication:** Yes.

Status	2400, 5400 Series	4600, 5600 Series	1400, 1600, 4400, 6400, 9500 Series	9600 Series	9608, 9611, J139, J159, J169, J179, J189	9621, 9641	T-Series, M-Series
- On.	<Label> ◀	<Label>	Green on	Red on	Green on	 Green	▲ On
- Off.	<Label>	<Label>	Off	Off	Off	 Grey	Off

User Admin: No.

**Phone Support** Note that support for particular phone models is also dependant on the system software level.

<b>Analog:</b> No	<b>20 Series:</b> Yes	<b>4100 Series:</b> No	<b>6400 Series:</b> Yes	<b>D100:</b> No
<b>1100 Series:</b> No	<b>2400 Series:</b> Yes [1]	<b>4400 Series:</b> Yes	<b>7400 Series:</b> No	<b>M-Series:</b> No
<b>1200 Series:</b> No	<b>3600 Series:</b> No	<b>4600 Series:</b> Yes [1]	<b>9040:</b> Yes	<b>T-Series:</b> No
<b>1400 Series:</b> Yes [1]	<b>3700 Series:</b> No	<b>5400 Series:</b> Yes	<b>9500 Series:</b> Yes	<b>T3/T3 IP Series:</b> No
<b>1600 Series:</b> Yes [1]	<b>3810:</b> Yes	<b>5600 Series:</b> Yes [1]	<b>9600 Series:</b> Yes	

1. Not 1403, 1603, 4601, 4602, 5601 and 5602 except where 4602 is supported on Release 2.1 and 3.0DT software.

---

## After Call Work

This button is used by users configured as a Customer Call Reporter (CCR) Agent (**User | Telephony | Supervisor Settings**) and working with the CCR application. It shows the CCR agent their current After Call Work (ACW) status and allow them to manually change status. While in ACW state, the agent will not receive hunt group calls.

CCR Agents can be automatically put into and taken out of ACW by the system if the user is configured for Automatic After Call Work (**User | Telephony | Supervisor Settings**). Those users must have an **After Call Work** button.

**\* Note:**

CCR is not supported in IP Office release 9.1 and later.

**Action:** Advanced | Miscellaneous | After Call Work

**Action Data:** None.

**Default Label:** ACWrk or After Call Work.

**Toggles:** Yes.

**Status Indication:** Yes. Required.

Status	2400, 5400 Series	4600, 5600 Series	1400, 1600, 4400, 6400, 9500 Series	9600 Series	9608, 9611, J139, J169, J159, J179, J189	9621, 9641	T-Series, M-Series
- On.	<Label> ◀	<Label>	Green on	Red on	Green on	■ Green	▲ On
- Off.	<Label>	<Label>	Off	Off	Off	■ Grey	Off

User Admin: No.

Phone Support Note that support for particular phone models is also dependant on the system software level.

<b>Analog:</b> No	<b>20 Series:</b> No	<b>4100 Series:</b> No	<b>6400 Series:</b> No	<b>D100:</b> Yes
<b>1100 Series:</b> Yes	<b>2400 Series:</b> Yes [1]	<b>4400 Series:</b> No	<b>7400 Series:</b> No	<b>M-Series:</b> Yes
<b>1200 Series:</b> Yes	<b>3600 Series:</b> No	<b>4600 Series:</b> Yes [1]	<b>9040:</b> No	<b>T-Series:</b> Yes
<b>1400 Series:</b> Yes [1]	<b>3700 Series:</b> No	<b>5400 Series:</b> Yes [1]	<b>9500 Series:</b> Yes	
<b>1600 Series:</b> Yes [1]	<b>3810:</b> No	<b>5600 Series:</b> Yes [1]	<b>9600 Series:</b> Yes	

1. Not 1403, 1603, 2402, 4601, 4602, 5402, 5601 and 5602.

## Appearance

Creates a call appearance button. This can be used to answer and make calls. Users with multiple call appearance buttons can handle multiple calls.

Call appearance functions, assigned to buttons that do not have status lamps or icons, are automatically disabled until the user logs in at a phone with suitable buttons.

Appearance buttons can be set with a ring delay if required or to not ring. This does not affect the visual alerting displayed next to the button. The delay uses the user's Ring Delay (**User | Telephony | Multi-line Options**) setting.

Details

**Action:** Appearance | Appearance.

**Action Data:** Optional text label.

**Default Label:** a=.

**Toggles:** No.

**Status Indication:** Yes, required. See “Call Appearance Button Indication” in *Administering IP Office with Manager*.

User Admin: No.

Phone Support Note that support for particular phone models is also dependant on the system software level.

<b>Analog:</b> No	<b>20 Series:</b> No	<b>4100 Series:</b> Yes [1]	<b>6400 Series:</b> Yes	<b>D100:</b> No
<b>1100 Series:</b> No	<b>2400 Series:</b> Yes	<b>4400 Series:</b> Yes	<b>7400 Series:</b> Yes [1]	<b>M-Series:</b> Yes [1]
<b>1200 Series:</b> No	<b>3600 Series:</b> Yes	<b>5400 Series:</b> Yes	<b>9040:</b> Yes	<b>T-Series:</b> Yes [1]
<b>1400 Series:</b> Yes	<b>3700 Series:</b> No	<b>4600 Series:</b> Yes	<b>9500 Series:</b> Yes	
<b>1600 Series:</b> Yes	<b>3810:</b> Yes	<b>5600 Series:</b> Yes	<b>9600 Series:</b> Yes	

1. 4100 Series and 7400 Series phones support virtual call appearance button operation. This also applies to T7000, T7100, M7100 and M7100N phones and the Audio Conferencing Unit (ACU).

## Virtual Call Appearances

4100 Series and 7400 Series phones support virtual call appearance button operation. This also applies to T7000, T7100, M7100 and M7100N phones and the Audio Conferencing Unit (ACU).

Virtual call appearance operation is similar to an analog phone with call waiting enabled. However, it does not use the call waiting on/off settings, instead it uses call appearance buttons.

The number of virtual call appearances is set by the call appearance buttons programmed in the user's settings. These must be programmed as a single block start from button 1. It is recommended that only a maximum of 3 call appearances are used, however the user must have at least 1 call appearance programmed in order to make and receive calls.

Virtual Call Appearance Usability

If the user goes off-hook, they are connected to the alerting call if any, else to dial tone in order to make an outgoing call. This uses one of their virtual call appearance buttons.

With a call connected:

- If another call arrives on another virtual call appearance, the user will hear a call waiting tone on the set. The display, if the phone has one, will switch between details of the current and the waiting caller.
- If the user presses **Hold**, the connected call is placed on hold and:

If there are any available virtual call appearances, dial tone is heard. This allows the user to make a call or to use short codes that may affect the held or waiting calls. The following are some of the default short codes that can be used:

- **\*26: Clear CW** Drop the previous call and answer the waiting call.
- **\*52: Clear Call** Drop the previous call.
- **\*47: Conference Add** Start a conference between the user and any held calls.
- Else, if there is a call waiting, that call is answered.
- Else, if there is a call on hold, that call is reconnected.

If the user presses **Release** or **Drop** or goes on-hook during a call, the current call is ended and the user's phone returns to idle. If there is a waiting call, it starts ringing. The user can answer the call by going off hook or pressing **Hold**.

With the phone idle:

If the user goes off hook:

- The first alerting call appearance is answered if any.
- Else, the first idle call appearance is seized and the user hears dial tone.
- The user can press **Hold** to switch between virtual call appearances. This will answer or retrieve any call on next virtual call appearance or else hear dial tone to make a call.

With the phone idle but a call alerting:

Going off-hook or pressing **Hold** will answer the call.

When all the users virtual call appearances are in use, they are busy to any further calls. Calls will follow forward on busy if set, else go to voicemail is available or else get busy indication.

The only other appearance button controls applied and supported are

**Reserve Last CA** This setting can be enabled for the extension user. When selected, the last available call appearance is reserved for outgoing calls only. For example, for a user with 3 call appearances, they return busy to any further calls when 2 virtual appearances are in use. The extension user can press hold to get dial tone on the reserved call appearance. An available call appearance is also required when using **Feature 70** to initiate a call transfer.

**Coverage Appearances** Other users can have Coverage Appearance buttons set to provided coverage to the virtual call appearance user. The virtual appearance users **Individual Coverage Time** setting is applied.



## Automatic Callback

Sets a ringback on the extension being called. When the target extension ends its current call, the ringback user is rung (for their set **No Answer Time**) and if they answer, a new call is made to the target extension.

Ringback can also be cleared using the Cancel Ring Back When Free function.

**Action:** Emulation | Automatic Callback.

**Action Data:** None.

**Default Label:** AutCB or Auto Callback.

**Toggles:** Yes.

**Status Indication:** Yes.

Status	2400, 5400 Series	4600, 5600 Series	1400, 1600, 4400, 6400, 9500 Series	9600 Series	9608, 9611, J139, J159, J169, J179, J189	9621, 9641	T-Series, M-Series
- On.	<Label> ◀	<Label>	Green on	Red on	Green on	■ Green	▲ On
- Off.	<Label>	<Label>	Off	Off	Off	■ Grey	Off

User Admin: Yes.

**Phone Support** Note that support for particular phone models is also dependant on the system software level.

<b>Analog:</b> No	<b>20 Series:</b> Yes	<b>4100 Series:</b> No	<b>6400 Series:</b> Yes	<b>D100:</b> Yes
<b>1100 Series:</b> Yes	<b>2400 Series:</b> Yes [1]	<b>4400 Series:</b> Yes	<b>7400 Series:</b> No	<b>M-Series:</b> Yes
<b>1200 Series:</b> Yes	<b>3600 Series:</b> No	<b>4600 Series:</b> Yes [1]	<b>9040:</b> Yes	<b>T-Series:</b> Yes
<b>1400 Series:</b> Yes [1]	<b>3700 Series:</b> No	<b>5400 Series:</b> Yes	<b>9500 Series:</b> Yes	
<b>1600 Series:</b> Yes [1]	<b>3810:</b> Yes	<b>5600 Series:</b> Yes [1]	<b>9600 Series:</b> Yes	

1. Not 1403, 1603, 4601, 4602, 5601 and 5602 except where 4602 is supported on Release 2.1 and 3.0DT software.

## Auto-Intercom Deny

Use the Auto-Intercom Deny function to block automatic intercom calls.

**Action:** Advanced | Do Not Disturb | Auto Intercom Deny.

**Action Data:** Blank.

**Default Label:** NoAI or No Auto Int Calls.

**Toggles:** Yes.

**Status Indication:** Yes.

Status	2400, 5400 Series	4600, 5600 Series	1400, 1600, 4400, 6400, 9500 Series	9600 Series	9608, 9611, J139, J159, J169, J179, J189	9621, 9641	T-Series, M-Series
- On.	<Label> ◀	<Label>	Green on	Red on	Green on	■ Green	▲ On
- Off.	<Label>	<Label>	Off	Off	Off	■ Grey	Off

**User Admin:** No.

**Phone Support** Note that support for particular phone models is also dependant on the system software level.

<b>Analog:</b> No	<b>20 Series:</b> Yes	<b>4100 Series:</b> No	<b>6400 Series:</b> Yes	<b>D100:</b> Yes
<b>1100 Series:</b> No	<b>2400 Series:</b> Yes [1]	<b>4400 Series:</b> Yes	<b>7400 Series:</b> No	<b>M-Series:</b> Yes
<b>1200 Series:</b> No	<b>3600 Series:</b> No	<b>4600 Series:</b> Yes [1]	<b>9040:</b> Yes	<b>T-Series:</b> Yes
<b>1400 Series:</b> Yes [1]	<b>3700 Series:</b> No	<b>5400 Series:</b> Yes	<b>9500 Series:</b> Yes	
<b>1600 Series:</b> Yes [1]	<b>3810:</b> Yes	<b>5600 Series:</b> Yes [1]	<b>9600 Series:</b> Yes	

1. Not 1403, 1603, 4601, 4602, 5601 and 5602 except where 4602 is supported on Release 2.1 and 3.0DT software.

## Automatic Intercom

Automatic intercom functions allow you to call an extension and have the call automatically answered on speaker phone after 3 beeps. The extension called must support a handsfree speaker. If the extension does not have a handsfree microphone then the user must use the

handset if they want to talk. If the extension is not free when called, the call is presented as a normal call on a call appearance button if available.

This feature can be used as part of handsfree announced transfers.

**Action:** Emulation | Automatic Intercom.

**Action Data:** User number or name.

This field can be left blank for number entry when pressed.

On large display phones, if configured without a preset target, this type of button will display an interactive button menu for target selection.

**Default Label:** lauto or Auto Intercom.

**Toggles:** No.

**Status Indication:** No.

User Admin: No.

**Phone Support** Note that support for particular phone models is also dependant on the system software level.

<b>Analog:</b> No	<b>20 Series:</b> Yes	<b>4100 Series:</b> No	<b>6400 Series:</b> Yes	<b>D100:</b> Yes
<b>1100 Series:</b> No	<b>2400 Series:</b> Yes [1]	<b>4400 Series:</b> Yes	<b>7400 Series:</b> No	<b>M-Series:</b> Yes
<b>1200 Series:</b> No	<b>3600 Series:</b> No	<b>4600 Series:</b> Yes [1]	<b>9040:</b> Yes	<b>T-Series:</b> Yes
<b>1400 Series:</b> Yes [1]	<b>3700 Series:</b> No	<b>5400 Series:</b> Yes	<b>9500 Series:</b> Yes	
<b>1600 Series:</b> Yes [1]	<b>3810:</b> Yes	<b>5600 Series:</b> Yes [1]	<b>9600 Series:</b> Yes	

1. Not 1403, 1603, 4601, 4602, 5601 and 5602 except where 4602 is supported on Release 2.1 and 3.0DT software.

---

## Break Out

This feature is usable within a system multi-site network. It allows a user on one system in the network to specify that the following dialing be processed by another system on the network as if the user dialed it locally on that other system.

On phones with a multi-line display, if the target system is not specified in the button settings, a menu of the available systems in the network is displayed from which a selection can be made.

**Action:** Advanced | Dial | Break Out.

**Action Data:** Optional. The system name or IP address of the required system can be specified. If no system name or IP address is set, on display phones a list of systems within the network is displayed when the button is pressed.

**Default Label:** BkOut or Breakout.

**Toggles:** No.

**Status Indication:** No.

User Admin: No.

**Phone Support** Note that support for particular phone models is also dependant on the system software level.

<b>Analog:</b> No	<b>20 Series:</b> Yes	<b>4100 Series:</b> No	<b>6400 Series:</b> Yes	<b>M-Series:</b> No
<b>1100 Series:</b> No	<b>2400 Series:</b> Yes [1]	<b>4400 Series:</b> Yes	<b>7400 Series:</b> No	<b>T-Series:</b> No
<b>1200 Series:</b> No	<b>3600 Series:</b> Yes	<b>4600 Series:</b> Yes [1]	<b>9040:</b> Yes	
<b>1400 Series:</b> Yes [1]	<b>3700 Series:</b> No	<b>5400 Series:</b> Yes [1]	<b>9500 Series:</b> Yes	
<b>1600 Series:</b> Yes [1]	<b>3810:</b> No	<b>5600 Series:</b> Yes [1]	<b>D100:</b> No	

1. Not 1403, 1603, 2402, 4601, 4602, 5402, 5601 and 5602 models.

---

## Bridged Appearance

Creates an appearance button that follows the state of another user's call appearance button. The bridged appearance can be used to make and answer calls on behalf of the call appearance user.

The bridged appearance button user must also have at least one call appearance button programmed.

Bridged appearance functions, assigned to buttons that do not have status lamps or icons, are automatically disabled until the user logs in at a phone with suitable buttons.

Appearance buttons can be set with a ring delay if required or to not ring. This does not affect the visual alerting displayed next to the button. The delay uses the user's Ring Delay (User | Telephony | Multi-line Options) setting.

**Action:** Appearance | Bridged Appearance.

**Action Data:** User name and call appearance button number.

**Default Label:** <user name><call appearance label>.

**Toggles:** No.

**Status Indication:** Yes. Required. See Bridge Appearance Button Indication.

User Admin: No.

**Phone Support** Note that support for particular phone models is also dependant on the system software level.

<b>Analog:</b> No	<b>20 Series:</b> No	<b>4100 Series:</b> No	<b>6400 Series:</b> Yes	<b>D100:</b> No
<b>1100 Series:</b> No	<b>2400 Series:</b> Yes	<b>4400 Series:</b> Yes	<b>7400 Series:</b> No	<b>M-Series:</b> Yes [1]
<b>1200 Series:</b> No	<b>3600 Series:</b> Yes	<b>4600 Series:</b> Yes	<b>9040:</b> Yes	<b>T-Series:</b> Yes [1]
<b>1400 Series:</b> Yes	<b>3700 Series:</b> No	<b>5400 Series:</b> Yes	<b>9500 Series:</b> Yes	
<b>1600 Series:</b> Yes	<b>3810:</b> Yes	<b>5600 Series:</b> Yes	<b>9600 Series:</b> Yes	

1. Not supported on T7000, T7100, M7100, M7100N and the Audio Conferencing Unit (ACU).

## Busy

Not used.

## Busy On Held

When on, busy on held returns busy to new calls while the user has an existing call on hold. While this feature can be used by users with appearance keys, it is not recommended as this overrides the basic call handling intent of appearance keys.

**Action:** Advanced | Busy | Busy on Held.

**Action Data:** 1 for on, 0 for off.

**Default Label:** BusyH.

**Toggles:** No.

**Status Indication:** No.

User Admin: No.

**Phone Support** Note that support for particular phone models is also dependant on the system software level.

<b>Analog:</b> No	<b>20 Series:</b> Yes	<b>4100 Series:</b> No	<b>6400 Series:</b> Yes	<b>D100:</b> No
<b>1100 Series:</b> No	<b>2400 Series:</b> Yes [1]	<b>4400 Series:</b> Yes	<b>7400 Series:</b> No	<b>M-Series:</b> No

*Table continues...*

<b>1200 Series:</b> No	<b>3600 Series:</b> No	<b>4600 Series:</b> Yes [1]	<b>9040:</b> Yes	<b>T-Series:</b> No
<b>1400 Series:</b> Yes [1]	<b>3700 Series:</b> No	<b>5400 Series:</b> Yes	<b>9500 Series:</b> No	
<b>1600 Series:</b> Yes [1]	<b>3810:</b> Yes	<b>5600 Series:</b> Yes [1]	<b>9600 Series:</b> No	

1. Not 1403, 1603, 2402, 4601, 4602, 5601 and 5602 except where 4602 is supported on Release 2.1 and 3.0DT software.

## Call Forwarding All

Switches forward unconditional on and sets the forward number to the number specified or prompts the user to enter a number if none is specified.

**Action:** Emulation | Call Forwarding All.

**Action Data:** Telephone number or blank for entry when pressed.

If blank, user's with a log in code will be prompted to enter that code to use this function.

On large display phones, if configured without a preset target, this type of button will display an interactive button menu for target selection.

**Default Label:** CFrwd or Call Forward All.

**Toggles:** Yes.

**Status Indication:** Yes.

Status	2400, 5400 Series	4600, 5600 Series	1400, 1600, 4400, 6400, 9500 Series	9600 Series	9608, 9611, J139, J159, J169, J179, J189	9621, 9641	T-Series, M-Series
- On.	<Label> ◀	<Label>	Green on	Red on	Green on	■ Green	▲ On
- Off.	<Label>	<Label>	Off	Off	Off	■ Grey	Off

User Admin: No.

**Phone Support** Note that support for particular phone models is also dependant on the system software level.

<b>Analog:</b> No	<b>20 Series:</b> Yes	<b>4100 Series:</b> No	<b>6400 Series:</b> Yes	<b>D100:</b> Yes
<b>1100 Series:</b> Yes	<b>2400 Series:</b> Yes [1]	<b>4400 Series:</b> Yes	<b>7400 Series:</b> No	<b>M-Series:</b> Yes

*Table continues...*

<b>1200 Series:</b> Yes	<b>3600 Series:</b> No	<b>4600 Series:</b> Yes [1]	<b>9040:</b> Yes	<b>T-Series:</b> Yes
<b>1400 Series:</b> Yes [1]	<b>3700 Series:</b> No	<b>5400 Series:</b> Yes	<b>9500 Series:</b> Yes	
<b>1600 Series:</b> Yes [1]	<b>3810:</b> Yes	<b>5600 Series:</b> Yes [1]	<b>9600 Series:</b> Yes	

1. Not 1403, 1603, 4601, 4602, 5601 and 5602 except where 4602 is supported on Release 2.1 and 3.0DT software.

## Call Intrude

This feature allows you to intrude on the existing connected call of the specified target user. All call parties are put into a conference and can talk to and hear each other. A **Call Intrude** attempt to a user who is idle becomes a Priority Call.

The ability to intrude and be intruded is controlled by two configuration settings, the Can Intrude (User | Telephony | Supervisor Settings) setting of the user intruding and the Cannot Be Intruded (User | Telephony | Supervisor Settings) setting of target being intruded on. The setting of any other internal party is ignored. By default, no users can intrude and all users are set to cannot be intruded.

The system support a range of other call intrusion methods in addition to this feature.

**Action:** Advanced | Call | Call Intrude.

**Action Data:** User number or blank for entry when pressed.

On large display phones, if configured without a preset target, this type of button will display an interactive button menu for target selection.

**Default Label:** Intru or Intrude.

**Toggles:** No.

**Status Indication:** No.

**User Admin:** No.

**Phone Support** Note that support for particular phone models is also dependant on the system software level.

<b>Analog:</b> No	<b>20 Series:</b> Yes	<b>4100 Series:</b> No	<b>6400 Series:</b> Yes	<b>D100:</b> No
<b>1100 Series:</b> No	<b>2400 Series:</b> Yes [1]	<b>4400 Series:</b> Yes	<b>7400 Series:</b> No	<b>M-Series:</b> Yes
<b>1200 Series:</b> No	<b>3600 Series:</b> No	<b>4600 Series:</b> Yes [1]	<b>9040:</b> Yes	<b>T-Series:</b> Yes

*Table continues...*

<b>1400 Series:</b> Yes [1]	<b>3700 Series:</b> No	<b>5400 Series:</b> Yes	<b>9500 Series:</b> Yes	
<b>1600 Series:</b> Yes [1]	<b>3810:</b> Yes	<b>5600 Series:</b> Yes [1]	<b>9600 Series:</b> Yes	

1. Not 1403, 1603, 4601, 4602, 5601 and 5602 except where 4602 is supported on Release 2.1 and 3.0DT software.

## Call Listen

This feature allows you to monitor another user's call without being heard. Monitoring can be accompanied by a tone heard by all parties. Use of the tone is controlled by the Beep on Listen setting on the System | Telephony | Tones & Music tab. The default for this setting is on. If enabled, this is the only indication of monitoring given to the monitored user. There is no phone display indication of monitoring.

 **Warning:**

The use of features to listen to a call without the other call parties being aware of that monitoring may be subject to local laws and regulations. Before enabling the feature you must ensure that you have complied with all applicable local laws and regulations. Failure to do so may result in severe penalties.

The use of call listen is dependant on:

The target being a member of the group set as the user's Monitor Group (User | Telephony | Supervisor Settings). The user does not have to be a member of the group.

The ability to intrude and be intruded is controlled by two configuration settings, the Can Intrude (User | Telephony | Supervisor Settings) setting of the user intruding and the Cannot Be Intruded (User | Telephony | Supervisor Settings) setting of target being intruded on. The setting of any other internal party is ignored. By default, no users can intrude and all users are set to cannot be intruded.

This feature uses system conference resources. If insufficient conference resource are available it will not be possible to use this feature.

A number of features are supported for call listening:

- Users can be given privacy features that allow them to indicate that a call cannot be monitored. See Private Calls.
- IP extensions can be monitored including those using direct media. Previously the monitoring of IP extensions could not be guaranteed.
- The monitoring call can be initiated even if the target user is not currently on a call and remains active until the monitoring user clears the monitoring call.
- The user who initiated the call listen can also record the call.

Intruding onto an a user doing silent monitoring (Call Listen) is turned into a silent monitoring call.



1400, 1600, 9500 and 9600 Series phones with a user button can initiate listening using that button if the target user meets the criteria for listening.

The system support a range of other call intrusion methods in addition to this feature.

**Action:** Advanced | Call | Call Listen.

**Action Data:** User number.

**Default Label:** Listn or Listen.

**Toggles:** No.

**Status Indication:** No.

User Admin: No.

**Phone Support** Note that support for particular phone models is also dependant on the system software level.

<b>Analog:</b> No	<b>20 Series:</b> Yes	<b>4100 Series:</b> No	<b>6400 Series:</b> Yes	<b>D100:</b> No
<b>1100 Series:</b> No	<b>2400 Series:</b> Yes [1]	<b>4400 Series:</b> Yes	<b>7400 Series:</b> No	<b>M-Series:</b> Yes
<b>1200 Series:</b> No	<b>3600 Series:</b> No	<b>4600 Series:</b> Yes [1]	<b>9040:</b> Yes	<b>T-Series:</b> Yes
<b>1400 Series:</b> Yes [1]	<b>3700 Series:</b> No	<b>5400 Series:</b> Yes	<b>9500 Series:</b> Yes	
<b>1600 Series:</b> Yes [1]	<b>3810:</b> Yes	<b>5600 Series:</b> Yes [1]	<b>9600 Series:</b> Yes	

1. Not 1403, 1603, 4601, 4602, 5601 and 5602 except where 4602 is supported on Release 2.1 and 3.0DT software.

---

## Call Log

This function provides access to a list of received calls.

**Action:** Advanced | Call | Call Log.

**Action Data:** None.

**Default Label:** Call Log.

**Toggles:** No.

**Status Indication:** No.

User Admin: No.

**Phone Support** This function is only supported on M-Series and T-Series phones with a display. Not supported on phones on a DECT systems.

## Call Park

Allows the user to park and unpark calls. The button can be used in two ways, either associated with a specified park slot number or unspecified.

When associated with a specific park slot number, the button will park and unpark calls from that park slot and indicate when a call is parked in that park slot. Similarly the Park buttons within application (for example SoftConsole and one-X Portal) can be used to park, retrieve and indicate parked calls.

When not associated with a specific park slot number, the button will park calls by assigning them a park slot number based on the users extension number. For example, for extension XXX, the first parked call is assigned to park slot XXX0, the next to XXX1 and so on up to XXX9. The button will indicate when there are parked calls in any of those slots. On the T7000 phone, only a single automatic part slot XXX0 is supported.

- With a call connected, pressing the button will park that call using a park slot number assigned by the system based on the extension number.
- With no call connected, pressing the button will display details of any calls parked by the extension and allow their retrieval.

**Action:** Emulation | Call Park.





**Action Data:** Optional. Either blank or a specific park slot number. Name ca

Park slot IDs can be up to 15 digits in length. Names can also be used for application park slots.

**Default Label:** CPark or Call Park.

**Toggles:** ✓.

**Status Indication:** ✓.

Status	2400, 5400 Series	4600, 5600 Series	1400, 1600, 4400, 6400, 9500 Series	9600 Series	9608, 9611, J139, J159, J169, J179, J189	9621, 9641	T-Series, M-Series
- Calls parked by extension	CPark ◆	CPark	Green flash	Red flash	Green flash	 Blue	 Slow flash
- Call Parked by other extension	CPark	CPark	Red flash	<b>Red on</b>	Red flash	 <b>Green</b>	 Slow flash
- No parked calls	CPark	CPark	Off	Off	Off	 Grey	Off

User Admin: Yes.

**Phone Support** Note that support for particular phone models is also dependant on the system software level.

<b>Analog:</b> No	<b>20 Series:</b> Yes	<b>4100 Series:</b> No	<b>6400 Series:</b> Yes	<b>D100:</b> Yes
<b>1100 Series:</b> No	<b>2400 Series:</b> Yes [1]	<b>4400 Series:</b> Yes	<b>7400 Series:</b> No	<b>M-Series:</b> Yes [2]
<b>1200 Series:</b> No	<b>3600 Series:</b> Yes	<b>5400 Series:</b> Yes [1]	<b>9040:</b> Yes	<b>T-Series:</b> Yes [2]
<b>1400 Series:</b> Yes [1]	<b>3700 Series:</b> No	<b>4600 Series:</b> Yes [1]	<b>9500 Series:</b> Yes	
<b>1600 Series:</b> Yes [1]	<b>3810:</b> Yes	<b>5600 Series:</b> Yes [1]	<b>9600 Series:</b> Yes	

1. Not 1403, 1603, 2402, 4601, 4602, 5402, 5601 and 5602.
2. M-Series/T-Series: The button is equivalent to **Feature 74**.

---

## Call Park and Page

Parks the user's current call into the park slot number specified on the **System | Telephony | Park & Page** tab, in the **Central Park Range** field.

On M/T-series phones, 14xx/16xx phones, and the 9504 phone, the user is presented with up to three Page Target Groups. On other 95xx/96xx phones, the Page action displays a scrolling list of possible Page Target Groups. The user may also directly enter a Page target number, or use the system Directory to find a Page target.

A call Parked within the Central Park Range (regardless of the origin of the Park action) can be retrieved by directly dialing the desired Central Park Range slot on which that call is Parked.

**Action:** Emulation | Call Park and Page.

**Action Data:** None.

**Default Label:** ParkPage

**Toggles:** No.

**Status Indication:** No.

User Admin: Yes.

**Phone Support** Note that support for particular phone models is also dependant on the system software level.

<b>Analog:</b> No	<b>20 Series:</b> No	<b>4100 Series:</b> No	<b>6400 Series:</b> No	<b>D100:</b> Yes
<b>1100 Series:</b> Yes	<b>2400 Series:</b> No	<b>4400 Series:</b> No	<b>7400 Series:</b> No	<b>M-Series:</b> Yes [1]
<b>1200 Series:</b> Yes	<b>3600 Series:</b> No	<b>5400 Series:</b> No	<b>9040:</b> Yes	<b>T-Series:</b> Yes [1]

*Table continues...*

<b>1400 Series:</b> Yes	<b>3700 Series:</b> No	<b>4600 Series:</b> No	<b>9500 Series:</b> Yes	
<b>1600 Series:</b> Yes	<b>3810:</b> No	<b>5600 Series:</b> No	<b>9600 Series:</b> Yes	

1. M-Series/T-Series: **Feature 74** is equivalent to this button when a Central Park Range is defined. On an M7000 phone, if this feature is invoked, the call always attempts to Park on the highest defined Central Park Range slot. See the Call Park and Page short code description for details.

## Call Park To Other Extension

Allows the user to park their current call against another user's extension. The parked call indication on that extension is then activated according to the telephone type.

If the target extension has a Call Park button with no specific park slot number, the parked call will be indicated by that button and can be unparked from the list of parked calls shown when that button is pressed.

The park slot number assigned to the parked call is based on the number of the extension parking the call. For example, calls parked by extension 201 are assigned the park slot ID 2010, 2011 and so on up to 2019 depending on the number of calls parked.

**Action:** Emulation | Call Park To Other Extension.



**Action Data:** User number. This field can be left blank for number entry when pressed.

On large display phones, if configured without a preset target, this type of button will display an interactive button menu for target selection.

**Default Label:** RPark or Call Park to Other.

**Toggles:** Yes .

**Status Indication:** Yes. This is the status indication on the extension parking the call.

Status	2400, 5400 Series	4600, 5600 Series	1400, 1600, 4400, 6400, 9500 Series	9600 Series	9608, 9611, J139, J159, J169, J179, J189	9621, 9641	T-Series, M-Series
- Parked call	RPark ◆	RPark	Green flash	Red flash	Green flash	 Blue	 Slow flash
- No parked call	RPark	RPark	Off	Off	Off	 Grey	Off

User Admin: Yes.

**Phone Support** Note that support for particular phone models is also dependant on the system software level.

<b>Analog:</b> No	<b>20 Series:</b> Yes	<b>4100 Series:</b> No	<b>6400 Series:</b> Yes	<b>D100:</b> Yes
<b>1100 Series:</b> No	<b>2400 Series:</b> Yes [1]	<b>4400 Series:</b> Yes	<b>7400 Series:</b> No	<b>M-Series:</b> Yes
<b>1200 Series:</b> No	<b>3600 Series:</b> No	<b>5400 Series:</b> Yes [1]	<b>9040:</b> Yes	<b>T-Series:</b> Yes
<b>1400 Series:</b> Yes [1]	<b>3700 Series:</b> No	<b>4600 Series:</b> Yes [1]	<b>9500 Series:</b> Yes	
<b>1600 Series:</b> Yes [1]	<b>3810:</b> Yes	<b>5600 Series:</b> Yes [1]	<b>9600 Series:</b> Yes	

1. Not 1403, 1603, 2402, 4601, 4602, 5402, 5601 and 5602.

---

## Call Pickup

Answer an alerting call on the system.

**Action:** Emulation | Call Pickup.

**Action Data:** None.

**Default Label:** CpkUp or Call Pickup Any.

**Toggles:** No.

**Status Indication:** No.

User Admin: Yes.

**Phone Support** Note that support for particular phone models is also dependant on the system software level.

<b>Analog:</b> No	<b>20 Series:</b> Yes	<b>4100 Series:</b> No	<b>6400 Series:</b> Yes	<b>D100:</b> No
<b>1100 Series:</b> No	<b>2400 Series:</b> Yes [1]	<b>4400 Series:</b> Yes	<b>7400 Series:</b> No	<b>M-Series:</b> Yes
<b>1200 Series:</b> No	<b>3600 Series:</b> Yes	<b>4600 Series:</b> Yes [1]	<b>9040:</b> Yes	<b>T-Series:</b> Yes
<b>1400 Series:</b> Yes [1]	<b>3700 Series:</b> No	<b>5400 Series:</b> Yes	<b>9500 Series:</b> Yes	
<b>1600 Series:</b> Yes [1]	<b>3810:</b> Yes	<b>5600 Series:</b> Yes [1]	<b>9600 Series:</b> Yes	

1. Not 1403, 1603, 4601, 4602, 5601 and 5602 except where 4602 is supported on Release 2.1 and 3.0DT software.

## Call Pickup Any

Pick up the first available ringing call on the system.

**Action:** Advanced | Call | Call Pickup Any.

**Action Data:** None.

**Default Label:** PickA or Pickup Any.

**Toggles:** No.

**Status Indication:** No.

User Admin: No.

**Phone Support** Note that support for particular phone models is also dependant on the system software level.

<b>Analog:</b> No	<b>20 Series:</b> Yes	<b>4100 Series:</b> No	<b>6400 Series:</b> Yes	<b>D100:</b> Yes
<b>1100 Series:</b> Yes	<b>2400 Series:</b> Yes [1]	<b>4400 Series:</b> Yes	<b>7400 Series:</b> No	<b>M-Series:</b> Yes
<b>1200 Series:</b> Yes	<b>3600 Series:</b> No	<b>4600 Series:</b> Yes [1]	<b>9040:</b> Yes	<b>T-Series:</b> Yes
<b>1400 Series:</b> Yes [1]	<b>3700 Series:</b> No	<b>5400 Series:</b> Yes	<b>9500 Series:</b> Yes	<b>T3/T3 IP Series:</b> No [2]
<b>1600 Series:</b> Yes [1]	<b>3810:</b> Yes	<b>5600 Series:</b> Yes [1]	<b>9600 Series:</b> Yes	

1. Not 1403, 1603, 4601, 4602, 5601 and 5602 except where 4602 is supported on Release 2.1 and 3.0DT software.
2. **T3 Phones:** Displays a list of call ringing from which the user can select a call to answer.
  - **Classic/Comfort icon:** Displays .
  - **DSS Link LED:** None.

## Call Pickup Group

Pick up a call ringing any hunt group of which the user is a member or set to pick up calls from a specific group.

The user can use this feature even if their membership of the group is currently set as disabled.

**Action:** Advanced | Call | Call Pickup Group.

**Action Data:** Optional. To pick up calls from a specific group, use the group number or name.

**Default Label:** PickG or Pickup Group.

**Toggles:** No.

**Status Indication:** No.

**User Admin:** No.

**Phone Support** Note that support for particular phone models is also dependant on the system software level.

<b>Analog:</b> No	<b>20 Series:</b> Yes	<b>4100 Series:</b> No	<b>6400 Series:</b> Yes	<b>D100:</b> Yes
<b>1100 Series:</b> Yes	<b>2400 Series:</b> Yes [1]	<b>4400 Series:</b> Yes	<b>7400 Series:</b> No	<b>M-Series:</b> Yes
<b>1200 Series:</b> Yes	<b>3600 Series:</b> No	<b>4600 Series:</b> Yes [1]	<b>9040:</b> Yes	<b>T-Series:</b> Yes
<b>1400 Series:</b> Yes [1]	<b>3700 Series:</b> No	<b>5400 Series:</b> Yes	<b>9500 Series:</b> Yes	<b>T3/T3 IP Series:</b> No [2]
<b>1600 Series:</b> Yes [1]	<b>3810:</b> Yes	<b>5600 Series:</b> Yes [1]	<b>9600 Series:</b> Yes	

1. Not 1403, 1603, 4601, 4602, 5601 and 5602 except where 4602 is supported on Release 2.1 and 3.0DT software.
2. May have limited support on some specific T3 phone models as detailed below.

**T3 Phones:** Displays a list of calls ringing the hunt group from which the user can select which call to answer.

- **Classic/Comfort icon:** Displays ■■■ followed by group name.
- **DSS Link LED:** None.

M-Series/T-Series: The button is equivalent to **Feature 75**.

---

## Call Pickup Members

This feature can be used to pick up any call to an extension that is a member of the hunt group specified. The call picked up does not have to be a hunt group call. The function includes group members even if their membership of the group is currently disabled.

- **Action:** Advanced | Call | Call Pickup Members.
- **Action Data:** Group number or name.
- **Default Label:** PickM or Pickup Members.
- **Toggles:** No.
- **Status Indication:** Yes (11.1 SP1)
  - On suitable phones, pressing the button displays a list of any group member with a call waiting to be answered. Pressing the button next to the user name answers their call.
- **User Admin:** No.

- **Phone Support** Note that support for particular phone models is also dependant on the system software level.

<b>Analog:</b> No	<b>20 Series:</b> Yes	<b>4100 Series:</b> No	<b>6400 Series:</b> Yes	<b>D100:</b> No
<b>1100 Series:</b> No	<b>2400 Series:</b> Yes [1]	<b>4400 Series:</b> Yes	<b>7400 Series:</b> No	<b>M-Series:</b> Yes
<b>1200 Series:</b> No	<b>3600 Series:</b> No	<b>4600 Series:</b> Yes [1]	<b>9040:</b> Yes	<b>T-Series:</b> Yes
<b>1400 Series:</b> Yes [1]	<b>3700 Series:</b> No	<b>5400 Series:</b> Yes	<b>9500 Series:</b> Yes	<b>T3/T3 IP Series:</b> No [2]
<b>1600 Series:</b> Yes [1]	<b>3810:</b> Yes	<b>5600 Series:</b> Yes [1]	<b>9600 Series:</b> Yes	

1. Not 1403, 1603, 4601, 4602, 5601 and 5602 except where 4602 is supported on Release 2.1 and 3.0DT software.
2. May have limited support on some specific T3 phone models as detailed below.

**T3 Phones:** Displays a list of calls ringing the hunt group from which the user can select which call to answer.

- **Classic/Comfort icon:** Displays ■■■ followed by group name.
- **DSS Link LED:** None.

## Call Queue

Transfer the call to the target extension if free or busy. If busy, the call is queued to wait for the phone to become free. This is similar to transfer except it allows you to transfer calls to a busy phone.

**Action:** Advanced | Call | Call Queue.

**Action Data:** User number.

**Default Label:** Queue.

**Toggles:** No.

**Status Indication:** No.

**User Admin:** No.

**Phone Support** Note that support for particular phone models is also dependant on the system software level.

<b>Analog:</b> No	<b>20 Series:</b> Yes	<b>4100 Series:</b> No	<b>6400 Series:</b> Yes	<b>D100:</b> No
-------------------	-----------------------	------------------------	-------------------------	-----------------

*Table continues...*



<b>1100 Series:</b> Yes	<b>2400 Series:</b> Yes [1]	<b>4400 Series:</b> Yes	<b>7400 Series:</b> No	<b>M-Series:</b> Yes
<b>1200 Series:</b> Yes	<b>3600 Series:</b> No	<b>4600 Series:</b> Yes [1]	<b>9040:</b> Yes	<b>T-Series:</b> Yes
<b>1400 Series:</b> Yes [1]	<b>3700 Series:</b> No	<b>5400 Series:</b> Yes	<b>9500 Series:</b> Yes	<b>T3/T3 IP Series:</b> No
<b>1600 Series:</b> Yes [1]	<b>3810:</b> Yes	<b>5600 Series:</b> Yes [1]	<b>9600 Series:</b> Yes	

1. Not 1403, 1603, 4601, 4602, 5601 and 5602 except where 4602 is supported on Release 2.1 and 3.0DT software.

## Call Record

This feature allows you to record a conversation and requires Voicemail Pro to be installed. An advice of recording warning will be given if configured on the voicemail system. The recording is placed in the mailbox specified by the user's **Manual Recording Mailbox** setting. Call recording also requires available conference resources similar to a three-party conference.

- **Action:** Advanced | Call | Call Record.
- **Action Data:** None.
- **Default Label:** Recor or Record.
- **Toggles:** Yes.
- **Status Indication:** Yes.
- **User Admin:** No.
- **Phone Support** Note that support for particular phone models is also dependant on the system software level.

<b>Analog:</b> No	<b>20 Series:</b> Yes	<b>4100 Series:</b> No	<b>6400 Series:</b> Yes	<b>D100:</b> Yes
<b>1100 Series:</b> Yes	<b>2400 Series:</b> Yes [1]	<b>4400 Series:</b> Yes	<b>7400 Series:</b> No	<b>M-Series:</b> Yes
<b>1200 Series:</b> Yes	<b>3600 Series:</b> No	<b>4600 Series:</b> Yes [1]	<b>9040:</b> Yes	<b>T-Series:</b> Yes
<b>1400 Series:</b> Yes [1]	<b>3700 Series:</b> No	<b>5400 Series:</b> Yes	<b>9500 Series:</b> Yes	<b>T3/T3 IP Series:</b> No
<b>1600 Series:</b> Yes [1]	<b>3810:</b> Yes	<b>5600 Series:</b> Yes [1]	<b>9600 Series:</b> Yes	<b>Vantage Connect Expansion:</b> ✓

1. Not 1403, 1603, 4601, 4602, 5601 and 5602 except where 4602 is supported on Release 2.1 and 3.0DT software.

---

## Call Screening

This function is used to enable or disable call screening. While enabled, when a caller is presented to the user's voicemail mailbox, if the user's phone is idle they will hear through the phone's handsfree speaker the caller leaving the message and can select to answer or ignore the call.

This feature is supported on 1408, 1416, 1608, 1616, 9500 Series, 9600 Series, M7310, M7310N, M7208, M7208N, M7324, M7324N, T7208, T7316 and T7316E phones. It can be used with both Embedded Voicemail and Voicemail Pro.

Call screening is only applied as follows:

- It is only applied to calls that have audible alerted at the user's extension before going to voicemail. This requires the user to have both voicemail coverage and call screening enabled and the phone's ringer not set to silent. However it is not applied if the user transfers the call to voicemail.
- It is only applied if the user's phone is idle, ie. not on a call or with a call held pending transfer or conference.
- Calls that ring the user, are then rerouted (for example follow a forward on busy setting) and then return to the user's mailbox are screened.

While a call is being screened, the phone can be used to either answer or ignore the screened call. Auto answer options are ignored.

### Answering a screened call

A screened call can be answered by pressing the **Answer** soft key (if displayed) or lifting the handset. Pressing the call appearance or line button on which the call is indicated will also answer the call.

When answered:

- The phone's microphone is unmuted and a normal call between the user and caller now exists.
- The voicemail recording stops but that portion of the call already recorded is left as a new message in the user's mailbox.

### Ignoring a screened call

A screened call can be ignored by pressing the Ignore soft key if displayed. On 1400, 1600, 9500 and 9600 Series phones, pressing the **SPEAKER** button will ignore the call. On M-Series and T-Series phones, pressing the **Release** key will ignore the call.

When ignored:

- The call continues to be recorded until the caller hangs up or transfers out of the mailbox.
- The user's phone returns to idle with call screening still enabled. However any other call that has already gone to voicemail is not screened.

### Screened call operation

While a call is being screened:

- The mailbox greeting played and the caller can be heard on the phone's speakerphone. The caller cannot hear the user.

- The user is regarded as being active on a call. They will not be presented with hunt group calls and additional personal calls use abbreviated ringing.
- 1400/1600/9500/9600 Series phones: If the phone's default audio path is set to headset or the phone is idle on headset, then the screened call is heard through the headset.
- Any additional calls that go to the user's mailbox when they are already screening a call, remain at the mailbox and are not screened even if the existing call being screened is ended.
- Making or answering another call while listening to a screened call is treated as ignoring the screened call. For users with **Answer Pre-Select** enabled (User | Telephony | Multi-line Options), pressing an appearance button to display details of a call is also treated as ignoring the screened call.
- Other users cannot access a call that is being screened. For example they cannot use call pickup, bridged appearance or line appearance buttons, call intrude or call acquire functions.
- Phone based administration cannot be accessed and the hold, transfer and conference buttons are ignored.
- The screened caller using DTMF breakout ends the call screening.

Enabling do not disturb overrides call screening except for calls from numbers in the user's do not disturb exceptions list.

Locking the phone overrides call screening.

Manual call recording cannot be applied to a call being screened.

While a call is being screened, it uses one of the available voicemail channels. If no voicemail channels are available, call screening does not occur.

#### **Warning:**

The use of features to listen to a call without the other call parties being aware of that monitoring may be subject to local laws and regulations. Before enabling the feature you must ensure that you have complied with all applicable local laws and regulations. Failure to do so may result in severe penalties.

#### **Details**

**Action:** Advanced | Call | Call Screening.

**Action Data:** None.



**Default Label:** CallScreen or Call Screening.

**Toggles:** Yes.

**Status Indication:** Yes.

Status	2400, 5400 Series	4600, 5600 Series	1400, 1600, 4400, 6400, 9500 Series	9600 Series	9608, 9611, J139, J159, J169, J179, J189	9621, 9641	T-Series, M-Series

*Table continues...*

- On.	<Label> ◀	<Label>	Green on	Red on	Green on	 Green	 On
- Off.	<Label>	<Label>	Off	Off	Off	 Grey	Off

**User Admin:** No.

Phone Support Note that support for particular phone models is also dependant on the system software level.

<b>Analog:</b> No	<b>20 Series:</b> No	<b>4100 Series:</b> No	<b>6400 Series:</b> No	<b>D100:</b> No
<b>1100 Series:</b> No	<b>2400 Series:</b> No	<b>4400 Series:</b> No	<b>7400 Series:</b> No	<b>M-Series:</b> Yes
<b>1200 Series:</b> No	<b>3600 Series:</b> No	<b>4600 Series:</b> No	<b>9040:</b> No	<b>T-Series:</b> Yes [1]
<b>1400 Series:</b> Yes [1]	<b>3700 Series:</b> No	<b>5400 Series:</b> No	<b>9500 Series:</b> Yes	<b>T3/T3 IP Series:</b> No
<b>1600 Series:</b> Yes [1]	<b>3810:</b> No	<b>5600 Series:</b> No	<b>9600 Series:</b> Yes	

1. Not 1403, 1603, T7406E.

## Call Steal

This function can be used with or without a specified user target.

If the target has alerting calls, the function will connect to the longest waiting call.

If the target has no alerting calls but does have a connected call, the function will take over the connected call, disconnecting the original user. This usage is subject to the **Can Intrude** setting of the **Call Steal** user and the **Cannot Be Intruded** setting of the target.

If no target is specified, the function attempts to reclaim the user's last ringing or transferred call if it has not been answered or has been answered by voicemail.

**Action:** Advanced | Call | Call Steal.

**Action Data:** User number or blank for last call transferred.

**Default Label:** Acquir or Acquire.

**Toggles:** No.

**Status Indication:** No.

**User Admin:** No.

**Phone Support** Note that support for particular phone models is also dependant on the system software level.

<b>Analog:</b> No	<b>20 Series:</b> Yes	<b>4100 Series:</b> No	<b>6400 Series:</b> Yes	<b>D100:</b> No
-------------------	-----------------------	------------------------	-------------------------	-----------------

*Table continues...*

<b>1100 Series:</b> No	<b>2400 Series:</b> Yes [1]	<b>4400 Series:</b> Yes	<b>7400 Series:</b> No	<b>M-Series:</b> Yes
<b>1200 Series:</b> No	<b>3600 Series:</b> No	<b>4600 Series:</b> Yes [1]	<b>9040:</b> Yes	<b>T-Series:</b> Yes
<b>1400 Series:</b> Yes [1]	<b>3700 Series:</b> No	<b>5400 Series:</b> Yes	<b>9500 Series:</b> Yes	<b>T3/T3 IP Series:</b> No [2]
<b>1600 Series:</b> Yes [1]	<b>3810:</b> Yes	<b>5600 Series:</b> Yes [1]	<b>9600 Series:</b> Yes	

1. Not 1403, 1603, 4601, 4602, 5601 and 5602 except where 4602 is supported on Release 2.1 and 3.0DT software.
2. May have limited support on some specific T3 phone models if detailed below.

---

## Call Waiting Off

Switches call waiting off for the user. This button function is obsolete. The Call Waiting On button function toggles on/off and indicates current status.

**Action:** Advanced | Call | Call Waiting Off.

**Action Data:** None.

**Default Label:** CWOff.

**Toggles:** No.

**Status Indication:** No.

**User Admin:** No.

**Phone Support** Note that support for particular phone models is also dependant on the system software level.

<b>Analog:</b> No	<b>20 Series:</b> Yes	<b>4100 Series:</b> No	<b>6400 Series:</b> Yes	<b>D100:</b> No
<b>1100 Series:</b> No	<b>2400 Series:</b> Yes [1]	<b>4400 Series:</b> Yes	<b>7400 Series:</b> No	<b>M-Series:</b> No
<b>1200 Series:</b> No	<b>3600 Series:</b> No	<b>4600 Series:</b> Yes [1]	<b>9040:</b> Yes	<b>T-Series:</b> No
<b>1400 Series:</b> Yes [1]	<b>3700 Series:</b> No	<b>5400 Series:</b> Yes	<b>9500 Series:</b> No	<b>T3/T3 IP Series:</b> No [2]
<b>1600 Series:</b> Yes [1]	<b>3810:</b> Yes	<b>5600 Series:</b> Yes [1]	<b>9600 Series:</b> No	

1. Not 1403, 1603, 2402, 4601, 4602, 5601 and 5602 except where 4602 is supported on Release 2.1 and 3.0DT software.
2. May have limited support on some specific T3 phone models if detailed below.

## Call Waiting On

Enables call waiting on the user's extension. When the user is on a call and another call arrives, they will hear a call waiting tone.

**\* Note:**

Call waiting does not operate for user's with call appearance buttons. See Call Waiting.

Details

**Action:** Advanced | Call | Call Waiting On.

**Action Data:** None.

**Default Label:** CWOn or Call Waiting On.

**Toggles:** Yes.

**Status Indication:** Yes.

Status	2400, 5400 Series	4600, 5600 Series	1400, 1600, 4400, 6400, 9500 Series	9600 Series	9608, 9611, J139, J159, J169, J179, J189	9621, 9641	T-Series, M-Series
- On.	<Label> ◀	<Label>	Green on	Red on	Green on	■ Green	▲ On
- Off.	<Label>	<Label>	Off	Off	Off	■ Grey	Off

**User Admin:** No.

**Phone Support** Note that support for particular phone models is also dependant on the system software level.

<b>Analog:</b> No	<b>20 Series:</b> Yes	<b>4100 Series:</b> No	<b>6400 Series:</b> Yes	<b>D100:</b> No
<b>1100 Series:</b> No	<b>2400 Series:</b> Yes [1]	<b>4400 Series:</b> Yes	<b>7400 Series:</b> No	<b>M-Series:</b> No
<b>1200 Series:</b> No	<b>3600 Series:</b> No	<b>4600 Series:</b> Yes [1]	<b>9040:</b> Yes	<b>T-Series:</b> No
<b>1400 Series:</b> Yes [1]	<b>3700 Series:</b> No	<b>5400 Series:</b> Yes	<b>9500 Series:</b> No	<b>T3/T3 IP Series:</b> No
<b>1600 Series:</b> Yes [1]	<b>3810:</b> Yes	<b>5600 Series:</b> Yes [1]	<b>9600 Series:</b> No	

1. Not 1403, 1603, 2402, 4601, 4602, 5601 and 5602 except where 4602 is supported on Release 2.1 and 3.0DT software.

## Call Waiting Suspend

Disables call waiting, if on, for the duration of the extension's next call.

**Action:** Advanced | Call | Call Waiting Suspend.

**Action Data:** None.

**Default Label:** CWSus.

**Toggles:** No.

**Status Indication:** No.

**User Admin:** No.

**Phone Support** Note that support for particular phone models is also dependant on the system software level.

<b>Analog:</b> No	<b>20 Series:</b> Yes	<b>4100 Series:</b> No	<b>6400 Series:</b> Yes	<b>D100:</b> No
<b>1100 Series:</b> No	<b>2400 Series:</b> Yes [1]	<b>4400 Series:</b> Yes	<b>7400 Series:</b> No	<b>M-Series:</b> No
<b>1200 Series:</b> No	<b>3600 Series:</b> No	<b>4600 Series:</b> Yes [1]	<b>9040:</b> Yes	<b>T-Series:</b> No
<b>1400 Series:</b> Yes [1]	<b>3700 Series:</b> No	<b>5400 Series:</b> Yes	<b>9500 Series:</b> No	<b>T3/T3 IP Series:</b> No
<b>1600 Series:</b> Yes [1]	<b>3810:</b> Yes	<b>5600 Series:</b> Yes [1]	<b>9600 Series:</b> No	

1. Not 1403, 1603, 2402, 4601, 4602, 5601 and 5602 except where 4602 is supported on Release 2.1 and 3.0DT software.

## Cancel All Forwarding

Cancels forward unconditional, forward on busy, forward on no answer, follow me and do not disturb if any of those are active on the user's extension.

- **Action:** Advanced | Call | Cancel All Forwarding.
- **Action Data:** None.
- **Default Label:** FwdOf or Call Forward Off.
- **Toggles:** No.
- **Status Indication:** No.
- **User Admin:** No.
- **Phone Support** Note that support for particular phone models is also dependant on the system software level.

<b>Analog:</b> No	<b>20 Series:</b> Yes	<b>4100 Series:</b> No	<b>6400 Series:</b> Yes	<b>D100:</b> No
<b>1100 Series:</b> No	<b>2400 Series:</b> Yes [1]	<b>4400 Series:</b> Yes	<b>7400 Series:</b> No	<b>M-Series:</b> Yes
<b>1200 Series:</b> No	<b>3600 Series:</b> No	<b>4600 Series:</b> Yes [1]	<b>9040:</b> Yes	<b>T-Series:</b> Yes
<b>1400 Series:</b> Yes [1]	<b>3700 Series:</b> No	<b>5400 Series:</b> Yes	<b>9500 Series:</b> Yes	<b>T3/T3 IP Series:</b> No
<b>1600 Series:</b> Yes [1]	<b>3810:</b> Yes	<b>5600 Series:</b> Yes [1]	<b>9600 Series:</b> Yes	<b>Vantage Connect Expansion:</b> ✓

1. Not 1403, 1603, 4601, 4602, 5601 and 5602 except where 4602 is supported on Release 2.1 and 3.0DT software.

---

## Cancel Leave Word Calling

Not supported. Provided for CTI emulation only. Cancels the last Leave Word Calling message originated by the user.

**Action:** Emulation | Cancel Leave Word Calling.

**Action Data:** None.

**Default Label:** CnLWC.

**Toggles:** No.

**Status Indication:** No.

**User Admin:** No.

**Phone Support** Note that support for particular phone models is also dependant on the system software level.

<b>Analog:</b> No	<b>20 Series:</b> Yes	<b>4100 Series:</b> No	<b>6400 Series:</b> Yes	<b>D100:</b> No
<b>1100 Series:</b> No	<b>2400 Series:</b> Yes [1]	<b>4400 Series:</b> Yes	<b>7400 Series:</b> No	<b>M-Series:</b> No
<b>1200 Series:</b> No	<b>3600 Series:</b> No	<b>4600 Series:</b> Yes [1]	<b>9040:</b> Yes	<b>T-Series:</b> No
<b>1400 Series:</b> Yes [1]	<b>3700 Series:</b> No	<b>5400 Series:</b> Yes	<b>9500 Series:</b> No	<b>T3/T3 IP Series:</b> No
<b>1600 Series:</b> Yes [1]	<b>3810:</b> Yes	<b>5600 Series:</b> Yes [1]	<b>9600 Series:</b> No	

1. Not 1403, 1603, 2402, 4601, 4602, 5601 and 5602 except where 4602 is supported on Release 2.1 and 3.0DT software.



---

## Cancel Ring Back When Free

Cancels any existing ring back set by the user, see Ring Back When Free. Note that the Ring Back When Free button toggles to set or cancel ring back when free and also indicates the current status.

**Action:** Advanced | Miscellaneous | Cancel Ring Back When Free.

**Action Data:** None.

**Default Label:** RBak-.

**Toggles:** No.

**Status Indication:** No.

**User Admin:** No.

**Phone Support** Note that support for particular phone models is also dependant on the system software level.

<b>Analog:</b> No	<b>20 Series:</b> Yes	<b>4100 Series:</b> No	<b>6400 Series:</b> Yes	<b>D100:</b> No
<b>1100 Series:</b> No	<b>2400 Series:</b> Yes [1]	<b>4400 Series:</b> Yes	<b>7400 Series:</b> No	<b>M-Series:</b> No
<b>1200 Series:</b> No	<b>3600 Series:</b> No	<b>4600 Series:</b> Yes [1]	<b>9040:</b> Yes	<b>T-Series:</b> No
<b>1400 Series:</b> Yes [1]	<b>3700 Series:</b> No	<b>5400 Series:</b> Yes	<b>9500 Series:</b> No	<b>T3/T3 IP Series:</b> No [2]
<b>1600 Series:</b> Yes [1]	<b>3810:</b> Yes	<b>5600 Series:</b> Yes [1]	<b>9600 Series:</b> No	

1. Not 1403, 1603, 2402, 4601, 4602, 5601 and 5602 except where 4602 is supported on Release 2.1 and 3.0DT software.
2. May have limited support on some specific T3 phone models if detailed below.

M-Series/T-Series: The button is equivalent to **Feature #2**.

---

## Channel Monitor

For Avaya use only. Configurable through web manager only.

## Clear Call

This feature can be used to end the last call put on hold. This can be used in scenarios where a first call is already on hold and simply ending the second call will cause an unsupervised transfer of the first call.

**Action:** Advanced | Call | Clear Call.

**Action Data:** None.

**Default Label:** Clear.

**Toggles:** No.

**Status Indication:** No.

**User Admin:** No.

**Phone Support** Note that support for particular phone models is also dependant on the system software level.

<b>Analog:</b> No	<b>20 Series:</b> Yes	<b>4100 Series:</b> No	<b>6400 Series:</b> Yes	<b>D100:</b> No
<b>1100 Series:</b> No	<b>2400 Series:</b> Yes [1]	<b>4400 Series:</b> Yes	<b>7400 Series:</b> No	<b>M-Series:</b> Yes
<b>1200 Series:</b> No	<b>3600 Series:</b> No	<b>4600 Series:</b> Yes [1]	<b>9040:</b> Yes	<b>T-Series:</b> Yes
<b>1400 Series:</b> Yes [1]	<b>3700 Series:</b> No	<b>5400 Series:</b> Yes	<b>9500 Series:</b> Yes	<b>T3/T3 IP Series:</b> No
<b>1600 Series:</b> Yes [1]	<b>3810:</b> Yes	<b>5600 Series:</b> Yes [1]	<b>9600 Series:</b> Yes	

1. Not 1403, 1603, 4601, 4602, 5601 and 5602 except where 4602 is supported on Release 2.1 and 3.0DT software.

## Clear CW

End the user's current call and answer any call waiting. Requires the user to also have call waiting indication on. This function does not work for users with multiple call appearance buttons.

**Action:** Advanced | Call | Clear CW.

**Action Data:** None.

**Default Label:** ClrCW.

**Toggles:** No.

**Status Indication:** No.

**User Admin:** No.

**Phone Support** Note that support for particular phone models is also dependant on the system software level.

<b>Analog:</b> No	<b>20 Series:</b> Yes	<b>4100 Series:</b> No	<b>6400 Series:</b> Yes	<b>D100:</b> No
<b>1100 Series:</b> No	<b>2400 Series:</b> Yes [1]	<b>4400 Series:</b> Yes	<b>7400 Series:</b> No	<b>M-Series:</b> No
<b>1200 Series:</b> No	<b>3600 Series:</b> No	<b>4600 Series:</b> Yes [1]	<b>9040:</b> Yes	<b>T-Series:</b> No
<b>1400 Series:</b> Yes [1]	<b>3700 Series:</b> No	<b>5400 Series:</b> Yes	<b>9500 Series:</b> No	<b>T3/T3 IP Series:</b> No
<b>1600 Series:</b> Yes [1]	<b>3810:</b> Yes	<b>5600 Series:</b> Yes [1]	<b>9600 Series:</b> No	

1. Not 1403, 1603, 2402, 4601, 4602, 5601 and 5602 except where 4602 is supported on Release 2.1 and 3.0DT software.

---

## Clear Hunt Group Night Service

Changes the specified hunt group from Night Service mode to 'In Service' mode. This button function is obsolete. The Set Hunt Group Night Service function can be used to toggle a group in/out of service and provides lamp status indication.

Setting and clearing hunt group night service can be done using either manual controls or using a system time profile. The use of both methods to control the night service status of a particular hunt group is not supported.

This function is not supported between systems in a multi-site network. It can only be used by a user currently logged onto the same system as hosting the hunt group.

**Action:** Advanced | Call | Clear Hunt Group Night Service.

**Action Data:** Group number.

If left blank, the button will affect all hunt groups of which the user is a member.

The **Set Hunt Group Night Service** and **Clear Hunt Group Night Service** short code and button features can be used to switch an SSL VPN service off or on respectively. The service is indicated by setting the service name as the telephone number or action data. Do not use quotation marks.

**Default Label:** HGNS-.

**Toggles:** No.

**Status Indication:** No.

User Admin: No.

**Phone Support** Note that support for particular phone models is also dependant on the system software level.

<b>Analog:</b> No	<b>20 Series:</b> Yes	<b>4100 Series:</b> No	<b>6400 Series:</b> Yes	<b>D100:</b> No
<b>1100 Series:</b> No	<b>2400 Series:</b> Yes [1]	<b>4400 Series:</b> Yes	<b>7400 Series:</b> No	<b>M-Series:</b> No
<b>1200 Series:</b> No	<b>3600 Series:</b> No	<b>4600 Series:</b> Yes [1]	<b>9040:</b> Yes	<b>T-Series:</b> No
<b>1400 Series:</b> Yes [1]	<b>3700 Series:</b> No	<b>5400 Series:</b> Yes	<b>9500 Series:</b> No	<b>T3/T3 IP Series:</b> No
<b>1600 Series:</b> Yes [1]	<b>3810:</b> Yes	<b>5600 Series:</b> Yes [1]	<b>9600 Series:</b> No	

1. Not 1403, 1603, 2402, 4601, 4602, 5601 and 5602 except where 4602 is supported on Release 2.1 and 3.0DT software.

---

## Clear Hunt Group Out Of Service

Changes the specified hunt groups status from Out of Service mode to 'In Service' mode. This button function is obsolete. The Set Hunt Group Out Of Service function can be used to toggle a group in/out of service and provides lamp status indication.

This function is not supported between systems in a multi-site network. It can only be used by a user currently logged onto the same system as hosting the hunt group.

**Action:** Advanced | Call | Clear Hunt Group Out of Service.

**Action Data:** Group number.

If left blank, the button will affect all hunt groups of which the user is a member.

**Default Label:** HGOS-.

**Toggles:** No.

**Status Indication:** No.

User Admin: No.

**Phone Support** Note that support for particular phone models is also dependant on the system software level.

<b>Analog:</b> No	<b>20 Series:</b> Yes	<b>4100 Series:</b> No	<b>6400 Series:</b> Yes	<b>D100:</b> No
<b>1100 Series:</b> No	<b>2400 Series:</b> Yes [1]	<b>4400 Series:</b> Yes	<b>7400 Series:</b> No	<b>M-Series:</b> No
<b>1200 Series:</b> No	<b>3600 Series:</b> No	<b>4600 Series:</b> Yes [1]	<b>9040:</b> Yes	<b>T-Series:</b> No
<b>1400 Series:</b> Yes [1]	<b>3700 Series:</b> No	<b>5400 Series:</b> Yes	<b>9500 Series:</b> No	<b>T3/T3 IP Series:</b> No

*Table continues...*

<b>1600 Series:</b> Yes [1]	<b>3810:</b> Yes	<b>5600 Series:</b> Yes [1]	<b>9600 Series:</b> No	
--------------------------------	------------------	--------------------------------	------------------------	--

1. Not 1403, 1603, 2402, 4601, 4602, 5601 and 5602 except where 4602 is supported on Release 2.1 and 3.0DT software.

---

## Clear Quota

Quotas can be assigned on outgoing calls to data services such as internet connections. The quota defines the number of minutes available for the service within a time frame set within the service, for example each day, each week or each month.

The Clear Quota function can be used to reset the quota for a specific service or for all services.

**Action:** Advanced | Call | Clear Quota.

**Action Data:** Service name" or "" (all services).

**Default Label:** Quota.

**Toggles:** No.

**Status Indication:** No.

User Admin: No.

**Phone Support** Note that support for particular phone models is also dependant on the system software level.

<b>Analog:</b> No	<b>20 Series:</b> Yes	<b>4100 Series:</b> No	<b>6400 Series:</b> Yes	<b>D100:</b> No
<b>1100 Series:</b> No	<b>2400 Series:</b> Yes [1]	<b>4400 Series:</b> Yes	<b>7400 Series:</b> No	<b>M-Series:</b> No
<b>1200 Series:</b> No	<b>3600 Series:</b> No	<b>4600 Series:</b> Yes [1]	<b>9040:</b> Yes	<b>T-Series:</b> No
<b>1400 Series:</b> Yes [1]	<b>3700 Series:</b> No	<b>5400 Series:</b> Yes	<b>9500 Series:</b> No	<b>T3/T3 IP Series:</b> No
<b>1600 Series:</b> Yes [1]	<b>3810:</b> Yes	<b>5600 Series:</b> Yes [1]	<b>9600 Series:</b> No	

1. Not 1403, 1603, 2402, 4601, 4602, 5601 and 5602 except where 4602 is supported on Release 2.1 and 3.0DT software.

## Coaching Intrusion

This feature allows the you to intrude on another user's call and to talk to them without being heard by the other call parties to which they can still talk. For example: User A is on a call with user B. When user C intrudes on user A, they can hear users A and B but can only be heard by user A.

The ability to intrude and be intruded is controlled by two configuration settings, the Can Intrude (User | Telephony | Supervisor Settings) setting of the user intruding and the Cannot Be Intruded (User | Telephony | Supervisor Settings) setting of target being intruded on. The setting of any other internal party is ignored. By default, no users can intrude and all users are set to cannot be intruded.

 **Warning:**

The use of features to listen to a call without the other call parties being aware of that monitoring may be subject to local laws and regulations. Before enabling the feature you must ensure that you have complied with all applicable local laws and regulations. Failure to do so may result in severe penalties.

The system support a range of other call intrusion methods in addition to this feature.

**Action:** Advanced | Call | Coaching Intrusion.

**Action Data:** User number or name or blank for entry when pressed.

**Default Label:** Coach or Coaching Intrusion.

**Toggles:** No.

**Status Indication:** No.

User Admin: No feedback provided..

**Phone Support** Note that support for particular phone models is also dependant on the system software level.

<b>Analog:</b> No.	<b>20 Series:</b> No.	<b>4100 Series:</b> No	<b>6400 Series:</b> No	<b>D100:</b> No
<b>1100 Series:</b> No.	<b>2400 Series:</b> No	<b>4400 Series:</b> No	<b>7400 Series:</b> No	<b>M-Series:</b> No
<b>1200 Series:</b> No.	<b>3600 Series:</b> No	<b>4600 Series:</b> No	<b>9040:</b> No	<b>T-Series:</b> No
<b>1400 Series:</b> Yes [1][2]	<b>3700 Series:</b> No	<b>5400 Series:</b> No	<b>9500 Series:</b> Yes [2]	<b>T3/T3 IP Series:</b> No
<b>1600 Series:</b> Yes [1]	<b>3810:</b> No	<b>5600 Series:</b> No	<b>9600 Series:</b> Yes	

1. Not 1403, 1603.
2. Not supported on non-IP telephones when using a headset.

---

## Conference

This function is intended for use with Avaya M-Series and T-Series phones only. When pressed, the button invokes the same conference process as dialing **Feature 3**.

**Action:** Advanced | Call | Conference.

**Action Data:** None.

**Default Label:** Conf or Conference Add.

**Toggles:** No.

**Status Indication:** No.

User Admin: No.

Phone Support This function is only supported on Avaya M-Series and T-Series phones.

M-Series/T-Series: The button is equivalent to **Feature 3**.

---

## Conference Add

Conference add controls can be used to place the user, their current call and any calls they have on hold into a conference. When used to start a new conference, the system automatically assigns a conference ID to the call. This is termed ad-hoc (impromptu) conferencing.

If the call on hold is an existing conference, the user and any current call are added to that conference. This can be used to add additional calls to an ad-hoc conference or to a meet-me conference. Conference add can be used to connect two parties together. After creating the conference, the user can drop from the conference and the two incoming calls remain connected.

For R11.0 and higher, the button has additional features:

- When pressed during a normal two-party call, that call is turned into a two-party conference call. This then provides access to the phone's other conference control, such as to add other parties, without interrupting the call.
- During an existing conference, pressing the button (on 1400, 1600, 9500, 9600 and J100 Series phones) provides a menu to enter the number of an additional party to add to the conference without putting the conference on hold. The other parties in the conference can hear the call progress and if answered the other party is immediately in the conference.

For further details refer to the Conferencing section.

**Action:** Advanced | Call | Conference Add.

**Action Data:** None.

**Default Label:** Conf+ or Conference Add.

**Toggles:** No.

**Status Indication:** No.

**User Admin:** No.

**Phone Support** Note that support for particular phone models is also dependant on the system software level.

<b>Analog:</b> No	<b>20 Series:</b> Yes	<b>4100 Series:</b> No	<b>6400 Series:</b> Yes	<b>D100:</b> No
<b>1100 Series:</b> No	<b>2400 Series:</b> Yes [1]	<b>4400 Series:</b> Yes	<b>7400 Series:</b> No	<b>M-Series:</b> Yes
<b>1200 Series:</b> No	<b>3600 Series:</b> No	<b>4600 Series:</b> Yes [1]	<b>9040:</b> Yes	<b>T-Series:</b> Yes
<b>1400 Series:</b> Yes [1]	<b>3700 Series:</b> No	<b>5400 Series:</b> Yes	<b>9500 Series:</b> Yes	<b>T3/T3 IP Series:</b> No
<b>1600 Series:</b> Yes [1]	<b>3810:</b> Yes	<b>5600 Series:</b> Yes [1]	<b>9600 Series:</b> Yes	

1. Not 1403, 1603, 4601, 4602, 5601 and 5602 except where 4602 is supported on Release 2.1 and 3.0DT software.

## Conference Meet Me

Conference meet-me refers to features that allow a user or caller to join a specific conference by using the conference's ID number (either pre-set in the control or entered at the time of joining the conference).

 **Note:**

Conference Meet Me features can create conferences that include only one or two parties. These are still conferences that are using resources from the host system's conference capacity.

### Conference ID Numbers

By default, ad hoc conferences are assigned numbers starting from 100 for the first conference in progress. Therefore, for conference Meet Me features specify a number away from this range ensure that the conference joined is not an ad hoc conference started by other users. It is not possible to join a conference using conference Meet Me features when the conference ID is in use by an ad-hoc conference.

**User Personal Conference Number** Each user's own extension number is treated as their own personal conference number. Only that user is able to start a conference using that number as the conference ID. Any one else attempting to start a conference with that number will find themselves in a conference but on hold until the owner also joins. Personal conferences are always hosted on the owner's system.



**\* Note:**

When a user calls from their mobile twinned number, the personal conference feature will only work if they access the conference using an FNE 18 service.

**Multi-Site Network Conferencing**

Meet Me conference IDs are now shared across a multi-site network. For example, if a conference with the ID 500 is started on one system, anyone else joining conference 500 on any system will join the same conference. Each conference still uses the conference resources of the system on which it was started and is limited by the available conference capacity of that system.

Previously separate conferences, each with the same conference ID, could be started on each system in a multi-site network.

Other Features

**Transfer to a Conference Button** A currently connected caller can be transferred into the conference by pressing **TRANSFER**, then the Conference Meet Me button and **TRANSFER** again to complete the transfer. This allows the user to place callers into the conference specified by the button without being part of the conference call themselves. This option is only support on Avaya phones with a fixed **TRANSFER** button (excluding T3 and T3 IP phones).

**Conference Button Status Indication** When the conference is active, any buttons associated with the conference ID indicate the active state.

**Details**

**Action:** Advanced | Call | Conference Meet Me.

**Action Data:** Conference number. This can be an alphanumeric value up to 15 characters.

**User Personal Conference Number** Each user's own extension number is treated as their own personal conference number. Only that user is able to start a conference using that number as the conference ID. Any one else attempting to start a conference with that number will find themselves in a conference but on hold until the owner also joins. Personal conferences are always hosted on the owner's system.

**\* Note:**

When a user calls from their mobile twinned number, the personal conference feature will only work if they access the conference using an FNE18 service.

**Default Label:** CnfMM <conference number> or Conf. Meet Me <conference number>.

**Toggles:** No.

**Status Indication:** Yes

<b>Status</b>	<b>2400, 5400 Series</b>	<b>4600, 5600 Series</b>	1400, 1600, 4400, 6400, 9500 Series	9600 Series	9608, 9611, J169, J159, J179, J189	9621, 9641	<b>T-Series, M-Series</b>
---------------	--------------------------	--------------------------	-------------------------------------	-------------	------------------------------------	------------	---------------------------

*Table continues...*

- Conference In Use	CnfMM ◀	CnfMM	Green on	Red on	Green on	■ Green	▲ On
- Conference Idle	CnfMM	CnfMM	Off	Off	Off	■ Grey	Off

For a Conference Meet Me configured to the user's own extension number, the indicator flashes red when the conference is in use but the user has not joined. There is also an abbreviated ring when the indicator changes to flashing red. It changes to solid red when the user joins.

User Admin: No.

**Phone Support** Note that support for particular phone models is also dependant on the system software level.

<b>Analog:</b> No	<b>20 Series:</b> Yes	<b>4100 Series:</b> No	<b>6400 Series:</b> Yes	<b>D100:</b> Yes
<b>1100 Series:</b> Yes	<b>2400 Series:</b> Yes [1]	<b>4400 Series:</b> Yes	<b>7400 Series:</b> No	<b>M-Series:</b> Yes
<b>1200 Series:</b> Yes	<b>3600 Series:</b> No	<b>4600 Series:</b> Yes [1]	<b>9040:</b> Yes	<b>T-Series:</b> Yes
<b>1400 Series:</b> Yes [1]	<b>3700 Series:</b> No	<b>5400 Series:</b> Yes	<b>9500 Series:</b> Yes	<b>T3/T3 IP Series:</b> No
<b>1600 Series:</b> Yes [1]	<b>3810:</b> Yes	<b>5600 Series:</b> Yes [1]	<b>9600 Series:</b> Yes	

1. Not 1403, 1603, 4601, 4602, 5601 and 5602 except where 4602 is supported on Release 2.1 and 3.0DT software.

---

## Consult

Not supported. Provided for CTI emulation only.

**Action:** Emulation | Consult.

**Action Data:** None.

**Default Label:** Cnslt.

**Toggles:** No.

**Status Indication:** No.

**User Admin:** No.

**Phone Support** Note that support for particular phone models is also dependant on the system software level.

<b>Analog:</b> No	<b>20 Series:</b> Yes	<b>4100 Series:</b> No	<b>6400 Series:</b> Yes	<b>D100:</b> No
<b>1100 Series:</b> No	<b>2400 Series:</b> Yes [1]	<b>4400 Series:</b> Yes	<b>7400 Series:</b> No	<b>M-Series:</b> No
<b>1200 Series:</b> No	<b>3600 Series:</b> No	<b>4600 Series:</b> Yes [1]	<b>9040:</b> Yes	<b>T-Series:</b> No
<b>1400 Series:</b> Yes [1]	<b>3700 Series:</b> No	<b>5400 Series:</b> Yes	<b>9500 Series:</b> No	<b>T3/T3 IP Series:</b> No
<b>1600 Series:</b> Yes [1]	<b>3810:</b> Yes	<b>5600 Series:</b> Yes [1]	<b>9600 Series:</b> No	

1. Not 1403, 1603, 2402, 4601, 4602, 5601 and 5602 except where 4602 is supported on Release 2.1 and 3.0DT software.

---

## Coverage Appearance

Creates a button that alerts when a call to the specified covered user is unanswered after that users **Individual Coverage Timer** expires.

The call coverage appearance button user must also have at least one call appearance button programmed. The covered user does not need to be using call appearance buttons.

Coverage appearance functions, assigned to buttons that do not have status lamps or icons, are automatically disabled until the user logs in at a phone with suitable buttons.

IP Office: Appearance buttons can be set with a ring delay if required or to not ring. This does not affect the visual alerting displayed next to the button. The delay uses the user's Ring Delay (User | Telephony | Multi-line Options) setting.

**Action:** Appearance | Coverage Appearance.

**Action Data:** User name.

**Default Label:** <user name>.

**Toggles:** No.

**Status Indication:** Yes. See Coverage Button Indication.

**User Admin:** No.

**Phone Support** Note that support for particular phone models is also dependant on the system software level.

<b>Analog:</b> No	<b>20 Series:</b> No	<b>4100 Series:</b> No	<b>6400 Series:</b> Yes	<b>D100:</b> No
<b>1100 Series:</b> No	<b>2400 Series:</b> Yes	<b>4400 Series:</b> Yes	<b>7400 Series:</b> No	<b>M-Series:</b> Yes [1]
<b>1200 Series:</b> No	<b>3600 Series:</b> Yes	<b>4600 Series:</b> Yes	<b>9040:</b> Yes	<b>T-Series:</b> Yes [1]

*Table continues...*

<b>1400 Series:</b> Yes	<b>3700 Series:</b> No	<b>5400 Series:</b> Yes	<b>9500 Series:</b> Yes	<b>T3/T3 IP Series:</b> No
<b>1600 Series:</b> Yes	<b>3810:</b> Yes	<b>5600 Series:</b> Yes	<b>9600 Series:</b> Yes	

1. Not supported on T7000, T7100, M7100, M7100N and the Audio Conferencing Unit (ACU).

## Dial

This action is used to dial the number contained in the Telephone Number field. A partial number can be enter for the user to complete. On buttons with a text label area, **Dial** followed by the number is shown.

- **Action Data:** Telephone number or partial telephone number.
- **Default Label:** Dial.
- **Toggles:** No.
- **Status Indication:** No.
- **User Admin:** No.
- **Phone Support** Note that support for particular phone models is also dependant on the system software level.

<b>Analog:</b> No	<b>20 Series:</b> Yes	<b>4100 Series:</b> No	<b>6400 Series:</b> Yes	<b>D100:</b> Yes
<b>1100 Series:</b> No	<b>2400 Series:</b> Yes [1]	<b>4400 Series:</b> Yes	<b>7400 Series:</b> No	<b>M-Series:</b> Yes
<b>1200 Series:</b> No	<b>3600 Series:</b> Yes	<b>4600 Series:</b> Yes [1]	<b>9040:</b> Yes	<b>T-Series:</b> Yes
<b>1400 Series:</b> Yes [1]	<b>3700 Series:</b> No	<b>5400 Series:</b> Yes	<b>9500 Series:</b> Yes	<b>T3/T3 IP Series:</b> No [2]
<b>1600 Series:</b> Yes [1]	<b>3810:</b> Yes	<b>5600 Series:</b> Yes [1]	<b>9600 Series:</b> Yes	<b>Vantage Connect Expansion:</b> ✓

1. Not 1403, 1603, 4601, 4602, 5601 and 5602 except where 4602 is supported on Release 2.1 and 3.0DT software.
2. T3 Phones
  - **Classic/Comfort icon:** Displays the telephone number set.
  - **DSS Link LED:** None.

---

## Dial 3K1

The call is presented to local exchange as a "3K1 Speech Call". Useful in some where voice calls cost less than data calls.

**Action:** Advanced | Dial | Dial 3K1.

**Action Data:** Telephone number.

**Default Label:** D3K1 or Dial 3K1.

**Toggles:** No.

**Status Indication:** No.

**User Admin:** No.

**Phone Support** Note that support for particular phone models is also dependant on the system software level.

<b>Analog:</b> No	<b>20 Series:</b> Yes	<b>4100 Series:</b> No	<b>6400 Series:</b> Yes	<b>D100:</b> No
<b>1100 Series:</b> No	<b>2400 Series:</b> Yes [1]	<b>4400 Series:</b> Yes	<b>7400 Series:</b> No	<b>M-Series:</b> Yes
<b>1200 Series:</b> No	<b>3600 Series:</b> No	<b>4600 Series:</b> Yes [1]	<b>9040:</b> Yes	<b>T-Series:</b> Yes
<b>1400 Series:</b> Yes [1]	<b>3700 Series:</b> No	<b>5400 Series:</b> Yes	<b>9500 Series:</b> Yes	<b>T3/T3 IP Series:</b> No
<b>1600 Series:</b> Yes [1]	<b>3810:</b> Yes	<b>5600 Series:</b> Yes [1]	<b>9600 Series:</b> Yes	

1. Not 1403, 1603, 4601, 4602, 5601 and 5602 except where 4602 is supported on Release 2.1 and 3.0DT software.

---

## Dial 56K

The call presented to local exchange as a "Data Call".

**Action:** Advanced | Dial | Dial 56K.

**Action Data:** Telephone number.

**Default Label:** D56K or Dial 56K.

**Toggles:** No.

**Status Indication:** No.

**User Admin:** No.

**Phone Support** Note that support for particular phone models is also dependant on the system software level.

<b>Analog:</b> No	<b>20 Series:</b> Yes	<b>4100 Series:</b> No	<b>6400 Series:</b> Yes	<b>D100:</b> No
<b>1100 Series:</b> No	<b>2400 Series:</b> Yes [1]	<b>4400 Series:</b> Yes	<b>7400 Series:</b> No	<b>M-Series:</b> Yes
<b>1200 Series:</b> No	<b>3600 Series:</b> No	<b>4600 Series:</b> Yes [1]	<b>9040:</b> Yes	<b>T-Series:</b> Yes
<b>1400 Series:</b> Yes [1]	<b>3700 Series:</b> No	<b>5400 Series:</b> Yes	<b>9500 Series:</b> Yes	<b>T3/T3 IP Series:</b> No
<b>1600 Series:</b> Yes [1]	<b>3810:</b> Yes	<b>5600 Series:</b> Yes [1]	<b>9600 Series:</b> Yes	

1. Not 1403, 1603, 4601, 4602, 5601 and 5602 except where 4602 is supported on Release 2.1 and 3.0DT software.

## Dial 64K

The call is presented to local exchange as a "Data Call".

**Action:** Advanced | Dial | Dial 64K.

**Action Data:** Telephone number.

**Default Label:** D64K or Dial 64K.

**Toggles:** No.

**Status Indication:** No.

**User Admin:** No.

**Phone Support** Note that support for particular phone models is also dependant on the system software level.

<b>Analog:</b> No	<b>20 Series:</b> Yes	<b>4100 Series:</b> No	<b>6400 Series:</b> Yes	<b>D100:</b> No
<b>1100 Series:</b> No	<b>2400 Series:</b> Yes [1]	<b>4400 Series:</b> Yes	<b>7400 Series:</b> No	<b>M-Series:</b> Yes
<b>1200 Series:</b> No	<b>3600 Series:</b> No	<b>4600 Series:</b> Yes [1]	<b>9040:</b> Yes	<b>T-Series:</b> Yes
<b>1400 Series:</b> Yes [1]	<b>3700 Series:</b> No	<b>5400 Series:</b> Yes	<b>9500 Series:</b> Yes	<b>T3/T3 IP Series:</b> No
<b>1600 Series:</b> Yes [1]	<b>3810:</b> Yes	<b>5600 Series:</b> Yes [1]	<b>9600 Series:</b> Yes	

1. Not 1403, 1603, 4601, 4602, 5601 and 5602 except where 4602 is supported on Release 2.1 and 3.0DT software.

## Dial CW

Call the specified extension number and force call waiting indication on if the extension is already on a call. The call waiting indication will not work if the extension called has multiple call appearance buttons in use.

**Action:** Advanced | Dial | Dial CW.

**Action Data:** User number.

**Default Label:** DCW or Dial Call Waiting.

**Toggles:** No.

**Status Indication:** No.

**User Admin:** No.

**Phone Support** Note that support for particular phone models is also dependant on the system software level.

<b>Analog:</b> No	<b>20 Series:</b> Yes	<b>4100 Series:</b> No	<b>6400 Series:</b> Yes	<b>D100:</b> No
<b>1100 Series:</b> No	<b>2400 Series:</b> Yes [1]	<b>4400 Series:</b> Yes	<b>7400 Series:</b> No	<b>M-Series:</b> Yes
<b>1200 Series:</b> No	<b>3600 Series:</b> No	<b>4600 Series:</b> Yes [1]	<b>9040:</b> Yes	<b>T-Series:</b> Yes
<b>1400 Series:</b> Yes [1]	<b>3700 Series:</b> No	<b>5400 Series:</b> Yes	<b>9500 Series:</b> Yes	<b>T3/T3 IP Series:</b> No
<b>1600 Series:</b> Yes [1]	<b>3810:</b> Yes	<b>5600 Series:</b> Yes [1]	<b>9600 Series:</b> Yes	

1. Not 1403, 1603, 4601, 4602, 5601 and 5602 except where 4602 is supported on Release 2.1 and 3.0DT software.

## Dial Direct

Automatic intercom functions allow you to call an extension and have the call automatically answered on speaker phone after 3 beeps. The extension called must support a handsfree speaker. If the extension does not have a handsfree microphone then the user must use the handset if they want to talk. If the extension is not free when called, the call is presented as a normal call on a call appearance button if available.

This feature can be used as part of handsfree announced transfers.

- **Action:** Advanced | Dial | Dial Direct.
- **Action Data:** User number or name or blank for entry when pressed.
- If left blank, the **Dial Direct** button can be used with User buttons to specify the target.

- **Default Label:** Dirct or Auto Intercom.
- **Toggles:** No.
- **Status Indication:** No.
- **User Admin:** No.
- **Phone Support** Note that support for particular phone models is also dependant on the system software level.

<b>Analog:</b> No	<b>20 Series:</b> Yes	<b>4100 Series:</b> No	<b>6400 Series:</b> Yes	<b>D100:</b> No
<b>1100 Series:</b> No	<b>2400 Series:</b> Yes [1]	<b>4400 Series:</b> Yes	<b>7400 Series:</b> No	<b>M-Series:</b> Yes
<b>1200 Series:</b> No	<b>3600 Series:</b> No	<b>4600 Series:</b> Yes [1]	<b>9040:</b> Yes	<b>T-Series:</b> Yes
<b>1400 Series:</b> Yes [1]	<b>3700 Series:</b> No	<b>5400 Series:</b> Yes	<b>9500 Series:</b> Yes	<b>T3/T3 IP Series:</b> No
<b>1600 Series:</b> Yes [1]	<b>3810:</b> Yes	<b>5600 Series:</b> Yes [1]	<b>9600 Series:</b> Yes	<b>Vantage Connect Expansion:</b> ✓

1. Not 1403, 1603, 4601, 4602, 5601 and 5602 except where 4602 is supported on Release 2.1 and 3.0DT software.

---

## Dial Emergency

Dials the number specified regardless of any outgoing call barring applicable to the user.

- Details of calls made using this function can be viewed using an **Emergency View** button. See [Emergency View](#) on page 1006.

**Action:** Advanced | Dial | Dial Emergency.

**Action Data:** Telephone number.

**Default Label:** Emrgy or Dial Emergency.

**Toggles:** No.

**Status Indication:** No.

**User Admin:** No.

**Phone Support** Note that support for particular phone models is also dependant on the system software level.

<b>Analog:</b> No	<b>20 Series:</b> Yes	<b>4100 Series:</b> No	<b>6400 Series:</b> Yes	<b>D100:</b> No
<b>1100 Series:</b> No	<b>2400 Series:</b> Yes [1]	<b>4400 Series:</b> Yes	<b>7400 Series:</b> No	<b>M-Series:</b> Yes

*Table continues...*



<b>1200 Series:</b> No	<b>3600 Series:</b> No	<b>4600 Series:</b> Yes [1]	<b>9040:</b> Yes	<b>T-Series:</b> Yes
<b>1400 Series:</b> Yes [1]	<b>3700 Series:</b> No	<b>5400 Series:</b> Yes	<b>9500 Series:</b> Yes	<b>T3/T3 IP Series:</b> No
<b>1600 Series:</b> Yes [1]	<b>3810:</b> Yes	<b>5600 Series:</b> Yes [1]	<b>9600 Series:</b> Yes	

1. Not 1403, 1603, 4601, 4602, 5601 and 5602 except where 4602 is supported on Release 2.1 and 3.0DT software.

---

## Dial Inclusion

This feature allows you to intrude on another user's call to talk to them. Their current call is put on hold while you talk and automatically reconnected when you end the intrusion. The intruder and the target extension can then talk but cannot be heard by the other party. This can include intruding into a conference call, where the conference will continue without the intrusion target.

During the intrusion all parties hear a repeated intrusion tone. When the intruder hangs-up the original call parties are reconnected. Attempting to hold a dial inclusion call simply ends the intrusion. The inclusion cannot be parked.

The ability to intrude and be intruded is controlled by two configuration settings, the Can Intrude (User | Telephony | Supervisor Settings) setting of the user intruding and the Cannot Be Intruded (User | Telephony | Supervisor Settings) setting of target being intruded on. The setting of any other internal party is ignored. By default, no users can intrude and all users are set to cannot be intruded.

The system support a range of other call intrusion methods in addition to this feature.

**Action:** Advanced | Dial | Dial Inclusion.

**Action Data:** User number or name or blank for user selection when pressed.

On large display phones, if configured without a preset target, this type of button will display an interactive button menu for target selection.

**Default Label:** Inclu or Dial Inclusion.

**Toggles:** No.

**Status Indication:** No.

**User Admin:** No.

**Phone Support** Note that support for particular phone models is also dependant on the system software level.

<b>Analog:</b> No	<b>20 Series:</b> Yes	<b>4100 Series:</b> No	<b>6400 Series:</b> Yes	<b>D100:</b> No
-------------------	-----------------------	------------------------	-------------------------	-----------------

*Table continues...*

<b>1100 Series:</b> No	<b>2400 Series:</b> Yes [1]	<b>4400 Series:</b> Yes	<b>7400 Series:</b> No	<b>M-Series:</b> Yes
<b>1200 Series:</b> No	<b>3600 Series:</b> No	<b>4600 Series:</b> Yes [1]	<b>9040:</b> Yes	<b>T-Series:</b> Yes
<b>1400 Series:</b> Yes [1]	<b>3700 Series:</b> No	<b>5400 Series:</b> Yes	<b>9500 Series:</b> Yes	<b>T3/T3 IP Series:</b> No
<b>1600 Series:</b> Yes [1]	<b>3810:</b> Yes	<b>5600 Series:</b> Yes [1]	<b>9600 Series:</b> Yes	

1. Not 1403, 1603, 4601, 4602, 5601 and 5602 except where 4602 is supported on Release 2.1 and 3.0DT software.

## Dial Intercom

Automatic intercom functions allow you to call an extension and have the call automatically answered on speaker phone after 3 beeps. The extension called must support a handsfree speaker. If the extension does not have a handsfree microphone then the user must use the handset if they want to talk. If the extension is not free when called, the call is presented as a normal call on a call appearance button if available.

This feature can be used as part of handsfree announced transfers.

**Action:** Emulation | Dial Intercom.

**Action Data:** User number or name or blank for number entry when pressed.

On large display phones, if configured without a preset target, this type of button will display an interactive button menu for target selection.

**Default Label:** Idial or Auto Intercom.

**Toggles:** No.

**Status Indication:** No.

**User Admin:** No.

**Phone Support** Note that support for particular phone models is also dependant on the system software level.

<b>Analog:</b> No	<b>20 Series:</b> Yes	<b>4100 Series:</b> No	<b>6400 Series:</b> Yes	<b>D100:</b> No
<b>1100 Series:</b> No	<b>2400 Series:</b> Yes [1]	<b>4400 Series:</b> Yes	<b>7400 Series:</b> No	<b>M-Series:</b> Yes
<b>1200 Series:</b> No	<b>3600 Series:</b> No	<b>4600 Series:</b> Yes [1]	<b>9040:</b> Yes	<b>T-Series:</b> Yes
<b>1400 Series:</b> Yes [1]	<b>3700 Series:</b> No	<b>5400 Series:</b> Yes	<b>9500 Series:</b> Yes	<b>T3/T3 IP Series:</b> No [2]

*Table continues...*

<b>1600 Series:</b> Yes [1]	<b>3810:</b> Yes	<b>5600 Series:</b> Yes [1]	<b>9600 Series:</b> Yes	
--------------------------------	------------------	--------------------------------	-------------------------	--

1. Not 1403, 1603, 4601, 4602, 5601 and 5602 except where 4602 is supported on Release 2.1 and 3.0DT software.
2. Limited support on some specific T3 phone models as detailed below.

#### T3 Phones:

- **Classic/Comfort icon:** Displays  followed by the set number.
- **DSS Link LED:** None.

M-Series/T-Series: The button is equivalent to **Feature 66 <number>**.

## Dial Paging

Makes a paging call to an extension or group specified. If no number is specified, this can be dialed after pressing the button. The target extension or group members must be free and must support handsfree auto-answer in order to hear the page.

On Avaya phones with a **CONFERENCE** button, a paged user can convert the page call into a normal call by pressing that button.

- **Action:** Advanced | Dial | Dial Paging.
- **Action Data:** User number or name or group number or name or blank for number entry when pressed.
- **Default Label:** Page.
- **Toggles:** No.
- **Status Indication:** No.
- **User Admin:** No.
- **Phone Support** Note that support for particular phone models is also dependant on the system software level.

<b>Analog:</b> No	<b>20 Series:</b> Yes	<b>4100 Series:</b> No	<b>6400 Series:</b> Yes	<b>D100:</b> No
<b>1100 Series:</b> No	<b>2400 Series:</b> Yes [1]	<b>4400 Series:</b> Yes	<b>7400 Series:</b> No	<b>M-Series:</b> Yes
<b>1200 Series:</b> No	<b>3600 Series:</b> No	<b>4600 Series:</b> Yes [1]	<b>9040:</b> Yes	<b>T-Series:</b> Yes
<b>1400 Series:</b> Yes [1]	<b>3700 Series:</b> No	<b>5400 Series:</b> Yes	<b>9500 Series:</b> Yes	<b>T3/T3 IP Series:</b> No [2]

*Table continues...*

<b>1600 Series:</b> Yes [1]	<b>3810:</b> Yes	<b>5600 Series:</b> Yes [1]	<b>9600 Series:</b> Yes	<b>Vantage Connect Expansion:</b> ✓
--------------------------------	------------------	--------------------------------	-------------------------	-------------------------------------

1. Not 1403, 1603, 4601, 4602, 5601 and 5602 except where 4602 is supported on Release 2.1 and 3.0DT software.
2. Limited support on some specific T3 phone models as detailed below.

**T3 Phones:**

- **Classic/Comfort icon:** Displays  followed by target number if set.
- **DSS Link LED:** None.

## Dial Physical Extn by Number

Call the specified extension using its Base Extension number setting. This is regardless of the current user logged in at that extension and any forwarding, follow me or do not disturb settings applied by the extension user. This function requires the extension to be assigned a default extension number in the system configuration. If the extension does not have a default extension number, Dial Physical Extn by Id should be used.

**Action:** Advanced | Dial | Dial Physical Extn by Number.

**Action Data:** Extension port base extension number.

**Default Label:** PhyEx or Dial Physical Extn.

**Toggles:** No.

**Status Indication:** No.

**User Admin:** No.

**Phone Support** Note that support for particular phone models is also dependant on the system software level.

<b>Analog:</b> No	<b>20 Series:</b> Yes	<b>4100 Series:</b> No	<b>6400 Series:</b> Yes	<b>D100:</b> No
<b>1100 Series:</b> No	<b>2400 Series:</b> Yes [1]	<b>4400 Series:</b> Yes	<b>7400 Series:</b> No	<b>M-Series:</b> Yes
<b>1200 Series:</b> No	<b>3600 Series:</b> No	<b>4600 Series:</b> Yes [1]	<b>9040:</b> Yes	<b>T-Series:</b> Yes
<b>1400 Series:</b> Yes [1]	<b>3700 Series:</b> No	<b>5400 Series:</b> Yes	<b>9500 Series:</b> Yes	<b>T3/T3 IP Series:</b> No
<b>1600 Series:</b> Yes [1]	<b>3810:</b> Yes	<b>5600 Series:</b> Yes [1]	<b>9600 Series:</b> Yes	

1. Not 1403, 1603, 4601, 4602, 5601 and 5602 except where 4602 is supported on Release 2.1 and 3.0DT software.

## Dial Physical Number by ID

Call the specified extension, if free, regardless of the current user logged in at that extension and any forwarding, follow me or do not disturb settings applied by the extension user. This function uses the port ID shown in the system configuration.

**Action:** Advanced | Dial | Dial Physical Extn by Id.

**Action Data:** Extension port ID number.

**Default Label:** DialP or Dial Extn by Id.

**Toggles:** No.

**Status Indication:** No.

**User Admin:** No.

**Phone Support** Note that support for particular phone models is also dependant on the system software level.

<b>Analog:</b> No	<b>20 Series:</b> Yes	<b>4100 Series:</b> No	<b>6400 Series:</b> Yes	<b>D100:</b> No
<b>1100 Series:</b> No	<b>2400 Series:</b> Yes [1]	<b>4400 Series:</b> Yes	<b>7400 Series:</b> No	<b>M-Series:</b> Yes
<b>1200 Series:</b> No	<b>3600 Series:</b> No	<b>4600 Series:</b> Yes [1]	<b>9040:</b> Yes	<b>T-Series:</b> Yes
<b>1400 Series:</b> Yes [1]	<b>3700 Series:</b> No	<b>5400 Series:</b> Yes	<b>9500 Series:</b> Yes	<b>T3/T3 IP Series:</b> No
<b>1600 Series:</b> Yes [1]	<b>3810:</b> Yes	<b>5600 Series:</b> Yes [1]	<b>9600 Series:</b> Yes	

1. Not 1403, 1603, 4601, 4602, 5601 and 5602 except where 4602 is supported on Release 2.1 and 3.0DT software.

## Dial Speech

This feature allows a short code to be created to force the outgoing call to use the Speech bearer capability.

**Action:** Advanced | Dial | Dial Speech.

**Action Data:** Telephone number.

**Default Label:** DSpch or Dial Speech.

**Toggles:** No.

**Status Indication:** No.

**User Admin:** No.

**Phone Support** Note that support for particular phone models is also dependant on the system software level.

<b>Analog:</b> No	<b>20 Series:</b> Yes	<b>4100 Series:</b> No	<b>6400 Series:</b> Yes	<b>D100:</b> No
<b>1100 Series:</b> No	<b>2400 Series:</b> Yes [1]	<b>4400 Series:</b> Yes	<b>7400 Series:</b> No	<b>M-Series:</b> Yes
<b>1200 Series:</b> No	<b>3600 Series:</b> No	<b>4600 Series:</b> Yes [1]	<b>9040:</b> Yes	<b>T-Series:</b> Yes
<b>1400 Series:</b> Yes [1]	<b>3700 Series:</b> No	<b>5400 Series:</b> Yes	<b>9500 Series:</b> Yes	<b>T3/T3 IP Series:</b> No
<b>1600 Series:</b> Yes [1]	<b>3810:</b> Yes	<b>5600 Series:</b> Yes [1]	<b>9600 Series:</b> Yes	

1. Not 1403, 1603, 4601, 4602, 5601 and 5602 except where 4602 is supported on Release 2.1 and 3.0DT software.

## Dial V110

The call is presented to local exchange as a "Data Call".

**Action:** Advanced | Dial | Dial V110.

**Action Data:** Telephone number.

**Default Label:** DV110 or Dial V110.

**Toggles:** No.

**Status Indication:** No.

**User Admin:** No.

**Phone Support** Note that support for particular phone models is also dependant on the system software level.

<b>Analog:</b> No	<b>20 Series:</b> Yes	<b>4100 Series:</b> No	<b>6400 Series:</b> Yes	<b>D100:</b> No
<b>1100 Series:</b> No	<b>2400 Series:</b> Yes [1]	<b>4400 Series:</b> Yes	<b>7400 Series:</b> No	<b>M-Series:</b> Yes
<b>1200 Series:</b> No	<b>3600 Series:</b> No	<b>4600 Series:</b> Yes [1]	<b>9040:</b> Yes	<b>T-Series:</b> Yes
<b>1400 Series:</b> Yes [1]	<b>3700 Series:</b> No	<b>5400 Series:</b> Yes	<b>9500 Series:</b> Yes	<b>T3/T3 IP Series:</b> No
<b>1600 Series:</b> Yes [1]	<b>3810:</b> Yes	<b>5600 Series:</b> Yes [1]	<b>9600 Series:</b> Yes	

1. Not 1403, 1603, 4601, 4602, 5601 and 5602 except where 4602 is supported on Release 2.1 and 3.0DT software.

## Dial V120

The call is presented to local exchange as a "Data Call".

**Action:** Advanced | Dial | Dial V120.

**Action Data:** Telephone number.

**Default Label:** DV120 or Dial V120.

**Toggles:** No.

**Status Indication:** No.

**User Admin:** No.

**Phone Support** Note that support for particular phone models is also dependant on the system software level.

<b>Analog:</b> No	<b>20 Series:</b> Yes	<b>4100 Series:</b> No	<b>6400 Series:</b> Yes	<b>D100:</b> No
<b>1100 Series:</b> No	<b>2400 Series:</b> Yes [1]	<b>4400 Series:</b> Yes	<b>7400 Series:</b> No	<b>M-Series:</b> Yes
<b>1200 Series:</b> No	<b>3600 Series:</b> No	<b>4600 Series:</b> Yes [1]	<b>9040:</b> Yes	<b>T-Series:</b> Yes
<b>1400 Series:</b> Yes [1]	<b>3700 Series:</b> No	<b>5400 Series:</b> Yes	<b>9500 Series:</b> Yes	<b>T3/T3 IP Series:</b> No
<b>1600 Series:</b> Yes [1]	<b>3810:</b> Yes	<b>5600 Series:</b> Yes [1]	<b>9600 Series:</b> Yes	

1. Not 1403, 1603, 4601, 4602, 5601 and 5602 except where 4602 is supported on Release 2.1 and 3.0DT software.

## Display Msg

Allows the sending of text messages to digital phones on the local system.

**Action:** Advanced | Dial | Display Msg.

**Action Data:** The telephone number takes the format "N";T" where:

- **N** is the target extension.
- **T** is the text message. Note that the ";" before the text and the " " after the text are required.

**Default Label:** Displ.

**Toggles:** No.

**Status Indication:** No.

**User Admin:** No.

**Phone Support** Note that support for particular phone models is also dependant on the system software level.

<b>Analog:</b> No	<b>20 Series:</b> Yes	<b>4100 Series:</b> No	<b>6400 Series:</b> Yes	<b>D100:</b> No
<b>1100 Series:</b> No	<b>2400 Series:</b> Yes [1]	<b>4400 Series:</b> Yes	<b>7400 Series:</b> No	<b>M-Series:</b> Yes
<b>1200 Series:</b> No	<b>3600 Series:</b> No	<b>4600 Series:</b> Yes [1]	<b>9040:</b> Yes	<b>T-Series:</b> Yes
<b>1400 Series:</b> Yes [1]	<b>3700 Series:</b> No	<b>5400 Series:</b> Yes	<b>9500 Series:</b> No	<b>T3/T3 IP Series:</b> No
<b>1600 Series:</b> Yes [1]	<b>3810:</b> Yes	<b>5600 Series:</b> Yes [1]	<b>9600 Series:</b> No	

1. Not 1403, 1603, 2402, 4601, 4602, 5601 and 5602 except where 4602 is supported on Release 2.1 and 3.0DT software.

## Dial Video

The call is presented to the local exchange as a "Video Call".

**Action:** Advanced | Dial | Dial Video.

**Action Data:** Telephone number.

**Default Label:** Dvide or Dial Video.

**Toggles:** No.

**Status Indication:** No.

**User Admin:** No.

**Phone Support** Note that support for particular phone models is also dependant on the system software level.

<b>Analog:</b> No	<b>20 Series:</b> Yes	<b>4100 Series:</b> No	<b>6400 Series:</b> Yes	<b>D100:</b> No
<b>1100 Series:</b> No	<b>2400 Series:</b> Yes [1]	<b>4400 Series:</b> Yes	<b>7400 Series:</b> No	<b>M-Series:</b> Yes
<b>1200 Series:</b> No	<b>3600 Series:</b> No	<b>4600 Series:</b> Yes [1]	<b>9040:</b> Yes	<b>T-Series:</b> Yes
<b>1400 Series:</b> Yes [1]	<b>3700 Series:</b> No	<b>5400 Series:</b> Yes	<b>9500 Series:</b> Yes	<b>T3/T3 IP Series:</b> No
<b>1600 Series:</b> Yes [1]	<b>3810:</b> Yes	<b>5600 Series:</b> Yes [1]	<b>9600 Series:</b> Yes	

1. Not 1403, 1603, 4601, 4602, 5601 and 5602 except where 4602 is supported on Release 2.1 and 3.0DT software.



## Directed Call Pickup

Pickup a call ringing at a specific extension or hunt group.

**Action:** Emulation | Directed Pickup.

**Action Data:** User number or name or group number or name or blank for number entry when pressed.

On large display phones, if configured without a preset target, this type of button will display an interactive button menu for target selection.

**Default Label:** DpkUp or Call Pickup.

**Toggles:** No.

**Status Indication:** No.

**User Admin:** No.

**Phone Support** Note that support for particular phone models is also dependant on the system software level.

<b>Analog:</b> No	<b>20 Series:</b> Yes	<b>4100 Series:</b> No	<b>6400 Series:</b> Yes	<b>D100:</b> Yes
<b>1100 Series:</b> Yes	<b>2400 Series:</b> Yes [1]	<b>4400 Series:</b> Yes	<b>7400 Series:</b> No	<b>M-Series:</b> Yes
<b>1200 Series:</b> Yes	<b>3600 Series:</b> No	<b>4600 Series:</b> Yes [1]	<b>9040:</b> Yes	<b>T-Series:</b> Yes
<b>1400 Series:</b> Yes [1]	<b>3700 Series:</b> No	<b>5400 Series:</b> Yes	<b>9500 Series:</b> Yes	<b>T3/T3 IP Series:</b> No [2]
<b>1600 Series:</b> Yes [1]	<b>3810:</b> Yes	<b>5600 Series:</b> Yes [1]	<b>9600 Series:</b> Yes	

1. Not 1403, 1603, 4601, 4602, 5601 and 5602 except where 4602 is supported on Release 2.1 and 3.0DT software.
2. Limited support on some specific T3 phone models as detailed below.  
M-Series/T-Series: The button is equivalent to **Feature 76**.

## Directory

A **Dir** button provides access to various directories and allows telephone number selection by dialed name matching. The directories available for searching depend on the phone type, see User Directory Access. Once they user has selected a directory, dialing on the dial pad letter keys is used to filter the display of matching names, with controls for scrolling through the matching names and for calling the currently displayed name.

**Details**

**Action:** Emulation | Directory.

**Action Data:** None.

**Default Label:** Dir.

**Toggles:** No.

**Status Indication:** No.

**User Admin:** No.

Phone Support Note that support for particular phone models is also dependant on the system software level.

<b>Analog:</b> No	<b>3600 Series:</b> No	<b>5400 Series:</b> Yes [1]	<b>9040:</b> No	<b>T3/T3 IP Series:</b> Yes
<b>1400 Series:</b> No	<b>3700 Series:</b> No	<b>4600 Series:</b> Yes [1]	<b>9500 Series:</b> No	
<b>1600 Series:</b> Yes [1]	<b>3810:</b> Yes	<b>5600 Series:</b> Yes [1]	<b>9600 Series:</b> No	
<b>20 Series:</b> Yes	<b>4100 Series:</b> No	<b>6400 Series:</b> Yes	<b>M-Series:</b> Yes	
<b>2400 Series:</b> Yes [1]	<b>4400 Series:</b> Yes	<b>7400 Series:</b> No	<b>T-Series:</b> Yes [1]	

1. Not 1603, 2402, 4601, 4602, 5402, 5601, 5602 and T7100 models.

**T3 Phones:**

- **Classic/Comfort icon:** Displays .
- **DSS Link LED:** None.

## Do Not Disturb Exception Add

Adds a number to the user's "Do Not Disturb Exception List". This can be the number of an internal user or a number to match the CLI of a particular external caller. Calls from that number, except hunt group calls, will ignore the user's Do Not Disturb setting. For further details see Do Not Disturb (DND).

**Action:** Advanced | Do Not Disturb | Do Not Disturb Exception Add.

**Action Data:** Telephone number or CLI. Up to 31 characters. For CLI numbers any prefix added by the system must also be included.

**Default Label:** DNDX+.

**Toggles:** No.

**Status Indication:** No.

**User Admin:** No.

**Phone Support** Note that support for particular phone models is also dependant on the system software level.

<b>Analog:</b> No	<b>20 Series:</b> Yes	<b>4100 Series:</b> No	<b>6400 Series:</b> Yes	<b>D100:</b> No
<b>1100 Series:</b> Yes	<b>2400 Series:</b> Yes [1]	<b>4400 Series:</b> Yes	<b>7400 Series:</b> No	<b>M-Series:</b> No
<b>1200 Series:</b> Yes	<b>3600 Series:</b> No	<b>4600 Series:</b> Yes [1]	<b>9040:</b> Yes	<b>T-Series:</b> No
<b>1400 Series:</b> Yes [1]	<b>3700 Series:</b> No	<b>5400 Series:</b> Yes	<b>9500 Series:</b> No	<b>T3/T3 IP Series:</b> No
<b>1600 Series:</b> Yes [1]	<b>3810:</b> Yes	<b>5600 Series:</b> Yes [1]	<b>9600 Series:</b> No	

1. Not 1403, 1603, 2402, 4601, 4602, 5601 and 5602 except where 4602 is supported on Release 2.1 and 3.0DT software.

---

## Do Not Disturb Exception Delete

Removes a number from the user's "Do Not Disturb Exception List". This can be the number of an internal user or a number to match the CLI of a particular external caller.

**Action:** Advanced | Do Not Disturb | Do Not Disturb Exception Delete.

**Action Data:** Telephone number or CLI.

**Default Label:** DNDX-.

**Toggles:** No.

**Status Indication:** No.

User Admin: No.

**Phone Support** Note that support for particular phone models is also dependant on the system software level.

<b>Analog:</b> No	<b>20 Series:</b> Yes	<b>4100 Series:</b> No	<b>6400 Series:</b> Yes	<b>D100:</b> No
<b>1100 Series:</b> Yes	<b>2400 Series:</b> Yes [1]	<b>4400 Series:</b> Yes	<b>7400 Series:</b> No	<b>M-Series:</b> No
<b>1200 Series:</b> Yes	<b>3600 Series:</b> No	<b>4600 Series:</b> Yes [1]	<b>9040:</b> Yes	<b>T-Series:</b> No
<b>1400 Series:</b> Yes [1]	<b>3700 Series:</b> No	<b>5400 Series:</b> Yes	<b>9500 Series:</b> No	<b>T3/T3 IP Series:</b> No

*Table continues...*

<b>1600 Series:</b> Yes [1]	<b>3810:</b> Yes	<b>5600 Series:</b> Yes [1]	<b>9600 Series:</b> No	
--------------------------------	------------------	--------------------------------	------------------------	--

1. Not 1403, 1603, 2402, 4601, 4602, 5601 and 5602 except where 4602 is supported on Release 2.1 and 3.0DT software.

## Do Not Disturb Off

Cancels the user's 'do not disturb' mode if set. This button function is obsolete as the do not disturb on function toggles on/off and indicates the button status.

**Action:** Advanced | Do Not Disturb | Do Not Disturb Off.

**Action Data:** None.

**Default Label:** DNDOf.

**Toggles:** No.

**Status Indication:** No.

**User Admin:** No.

**Phone Support** Note that support for particular phone models is also dependant on the system software level.

<b>Analog:</b> No	<b>20 Series:</b> Yes	<b>4100 Series:</b> No	<b>6400 Series:</b> Yes	<b>D100:</b> No
<b>1100 Series:</b> Yes	<b>2400 Series:</b> Yes [1]	<b>4400 Series:</b> Yes	<b>7400 Series:</b> No	<b>M-Series:</b> No
<b>1200 Series:</b> Yes	<b>3600 Series:</b> No	<b>4600 Series:</b> Yes [1]	<b>9040:</b> Yes	<b>T-Series:</b> No
<b>1400 Series:</b> Yes [1]	<b>3700 Series:</b> No	<b>5400 Series:</b> Yes	<b>9500 Series:</b> No	<b>T3/T3 IP Series:</b> No [2]
<b>1600 Series:</b> Yes [1]	<b>3810:</b> Yes	<b>5600 Series:</b> Yes [1]	<b>9600 Series:</b> No	

1. Not 1403, 1603, 2402, 4601, 4602, 5601 and 5602 except where 4602 is supported on Release 2.1 and 3.0DT software.
2. Limited support on some specific T3 phone models as detailed below.  
M-Series/T-Series: The button is equivalent to **Feature #85**.

## Do Not Disturb On

Enables the user's 'do not disturb' mode.

For CCR Agents, using this function button on the following phones will be requested the user to select a reason code - 1400, 1600, 2400, 4600, 5400, 5600, 9500 and 9600 Series phones with available programmable buttons.

**\* Note:**

CCR is not supported in IP Office release 9.1 and later.

- **Action:** Advanced | Do Not Disturb | Do Not Disturb On.
- **Action Data:** None.
- **Default Label:** DNDOn or Do Not Disturb.
- **Toggles:** Yes.
- **Status Indication:** No.
- **User Admin:** No.
- **Phone Support** Note that support for particular phone models is also dependant on the system software level.

<b>Analog:</b> No	<b>20 Series:</b> Yes	<b>4100 Series:</b> No	<b>6400 Series:</b> Yes	<b>D100:</b> Yes
<b>1100 Series:</b> Yes	<b>2400 Series:</b> Yes [1]	<b>4400 Series:</b> Yes	<b>7400 Series:</b> No	<b>M-Series:</b> Yes
<b>1200 Series:</b> Yes	<b>3600 Series:</b> No	<b>4600 Series:</b> Yes [1]	<b>9040:</b> Yes	<b>T-Series:</b> Yes
<b>1400 Series:</b> Yes [1]	<b>3700 Series:</b> No	<b>5400 Series:</b> Yes	<b>9500 Series:</b> Yes	<b>T3/T3 IP Series:</b> No [2]
<b>1600 Series:</b> Yes [1]	<b>3810:</b> Yes	<b>5600 Series:</b> Yes [1]	<b>9600 Series:</b> Yes	<b>Vantage Connect Expansion:</b> ✓

1. Not 1403, 1603, 4601, 4602, 5601 and 5602 except where 4602 is supported on Release 2.1 and 3.0DT software.
2. Limited support on some specific T3 phone models as detailed below.

M-Series/T-Series: The button is equivalent to **Feature 85**.

---

## Drop

This action is supported on phones which do not have a permanent **Drop** button.

For a currently connected call, pressing **Drop** disconnects the call. When drop is used to end a call, silence is returned to the user rather than dial tone. This is intended operation, reflecting that **Drop** is mainly intended for use by call center headset users.

If the user has no currently connected call, pressing **Drop** will redirect a ringing call using the user's **Forward on No Answer** setting if set or otherwise to voicemail if available.

For a conference call, on phones with a suitable display, **Drop** can be used to display the conference parties and allow selection of which party to drop from the conference.

**Action:** Emulation | Drop.

**Action Data:** None.

**Default Label:** Drop or Drop Call.

**Toggles:** No.

**Status Indication:** No.

**User Admin:** ✓.

Phone Support Note that support for particular phone models is also dependant on the system software level.

<b>Analog:</b> No	<b>20 Series:</b> Yes	<b>4100 Series:</b> No	<b>6400 Series:</b> No	<b>D100:</b> No
<b>1100 Series:</b> No	<b>2400 Series:</b> No	<b>4400 Series:</b> Yes	<b>7400 Series:</b> No	<b>M-Series:</b> No
<b>1200 Series:</b> No	<b>3600 Series:</b> Yes	<b>5400 Series:</b> Yes	<b>9040:</b> Yes	<b>T-Series:</b> No
<b>1400 Series:</b> No	<b>3700 Series:</b> No	<b>4600 Series:</b> Yes	<b>9500 Series:</b> Yes	<b>T3/T3 IP Series:</b> No
<b>1600 Series:</b> No	<b>3810:</b> Yes	<b>5600 Series:</b> Yes	<b>9600 Series:</b> Yes	

## Emergency View

A button set to this function indicates when a call has been made from the system to which the user's extension is registered. The definition of an emergency call is one connected call using a number configured as a **Dial Emergency** button or short code.

Pressing the button displays details of connected emergency calls in progress (the first 10). After pressing the button, the **History** option displays details of any previously connected emergency calls (the first 30) and allows deletion those call details.

Note that the button only shows emergency calls made from the system to which the user's extension is currently registered. The emergency call history for that system is shared by all users on the system, so updates to or deleting the history affects the details shown on all phones. The time shown in the call details, is the UTC time of the alarm calls.

- **Action:** Emulation | Emergency View.
- **Action Data:** None
- **Default Label:** 911–View or EView
- **Toggles:** No.
- **Status Indication:** Yes
  - The button gives a single ring and then flashes when there is a connected emergency call in progress.

- The button remains on when there are previous emergency calls in the alarm history.
- Note that there is a delay of a few seconds in changes of the lamp state.

- **User Admin:** No.
- **Phone Support:** Note that support for particular phone models is also dependent on the system software level.

<b>Analog:</b> No	<b>20 Series:</b> No	<b>4100 Series:</b> No	<b>6400 Series:</b> No	<b>6400 Series:</b> No
<b>1100 Series:</b> No	<b>2400 Series:</b> No	<b>4400 Series:</b> No	<b>7400 Series:</b> No	<b>J100 Series:</b> Yes
<b>1200 Series:</b> No	<b>3600 Series:</b> No	<b>4600 Series:</b> No	<b>9040:</b> No	<b>M-Series:</b> Yes
<b>1400 Series:</b> Yes	<b>3700 Series:</b> No	<b>5400 Series:</b> No	<b>9500 Series:</b> Yes	<b>T-Series:</b> Yes
<b>1600 Series:</b> Yes	<b>3810:</b> No	<b>5600 Series:</b> No	<b>9600:</b> Yes	

---

## Extn Login

**Extn Login** allows a user who has been configured with a **Login Code** (User | Telephony | Supervisor Settings) to take over ownership of any extension. That user's extension number becomes the extension number of the extension while they are logged. This is also called 'hot desking'.

Hot desking is not supported for H175, E129 and J129 telephones.

When used, the user is prompted to enter their extension number and then their log in code. Login codes of up to 15 digits are supported with **Extn Login** buttons. Login codes of up to 31 digits are supported with **Extn Login** short codes.

When a user logs in, as many of their user settings as possible are applied to the extension. The range of settings applied depends on the phone type and on the system configuration.

By default, on 1400 Series, 1600 Series, 9500 Series and 9600 Series phones, the user's call log and personal directory are accessible while they are logged in. This also applied to M-Series and T-Series telephones.

On other types of phone, those items such as call logs and speed dials are typically stored locally by the phone and will not change when users log in and log out.

If the user logging in was already logged in or associated with another phone, they will be automatically logged out that phone.



**Action:** Advanced | Extension | Extn Login.

**Action Data:** None.

**Default Label:** Login.

**Toggles:** Yes.

**Status Indication:** Yes.

<b>Status</b>	<b>2400, 5400 Series</b>	<b>4600, 5600 Series</b>	1400, 1600, 4400, 6400, 9500 Series	9600 Series	9608, 9611, J139, J159, J169, J179, J189	9621, 9641	<b>T-Series, M-Series</b>
- On.	<Label> ◀	<Label>	<b>Green on</b>	<b>Red on</b>	<b>Green on</b>	 <b>Green</b>	 On
- Off.	<Label>	<Label>	Off	Off	Off	 Grey	Off

**User Admin:** No.

**Phone Support** Note that support for particular phone models is also dependant on the system software level.

<b>Analog:</b> No	<b>20 Series:</b> Yes	<b>4100 Series:</b> No	<b>6400 Series:</b> Yes	<b>D100:</b> Yes
<b>1100 Series:</b> Yes	<b>2400 Series:</b> Yes [1]	<b>4400 Series:</b> Yes	<b>7400 Series:</b> No	<b>M-Series:</b> Yes
<b>1200 Series:</b> Yes	<b>3600 Series:</b> No	<b>4600 Series:</b> Yes [1]	<b>9040:</b> Yes	<b>T-Series:</b> Yes
<b>1400 Series:</b> Yes [1]	<b>3700 Series:</b> No	<b>5400 Series:</b> Yes	<b>9500 Series:</b> Yes	<b>T3/T3 IP Series:</b> No
<b>1600 Series:</b> Yes [1]	<b>3810:</b> Yes	<b>5600 Series:</b> Yes [1]	<b>9600 Series:</b> Yes	

1. Not 1403, 1603, 4601, 4602, 5601 and 5602 except where 4602 is supported on Release 2.1 and 3.0DT software.

---

## Extn Logout

Logs out a user from the phone. The phone will return to its normal default user, if an extension number is set against the physical extension settings in the configuration. Otherwise it takes the setting of the **NoUser** user. This action is obsolete as Extn Login can be used to log out an existing logged in user.

If the user who logged out was the default user for an extension, dialing \*36 will associate the extension with the user unless they are set to forced log in.

This feature cannot be used by a user who does not have a log in code.

- **Action:** Advanced | Extension | Extn Logout.
- **Action Data:** None.
- **Default Label:** Logof or Logout.
- **Toggles:** No.
- **Status Indication:** No.



- **User Admin:** No.
- **Phone Support** Note that support for particular phone models is also dependant on the system software level.

<b>Analog:</b> No	<b>20 Series:</b> Yes	<b>4100 Series:</b> No	<b>6400 Series:</b> Yes	<b>D100:</b> Yes
<b>1100 Series:</b> Yes	<b>2400 Series:</b> Yes [1]	<b>4400 Series:</b> Yes	<b>7400 Series:</b> No	<b>M-Series:</b> Yes
<b>1200 Series:</b> Yes	<b>3600 Series:</b> No	<b>4600 Series:</b> Yes [1]	<b>9040:</b> Yes	<b>T-Series:</b> Yes
<b>1400 Series:</b> Yes [1]	<b>3700 Series:</b> No	<b>5400 Series:</b> Yes	<b>9500 Series:</b> Yes	<b>T3/T3 IP Series:</b> No
<b>1600 Series:</b> Yes [1]	<b>3810:</b> Yes	<b>5600 Series:</b> Yes [1]	<b>9600 Series:</b> Yes	<b>Vantage Connect Expansion:</b> ✓

1. Not 1403, 1603, 4601, 4602, 5601 and 5602 except where 4602 is supported on Release 2.1 and 3.0DT software.
2. May have limited support on some specific T3 phone models if detailed below.

---

## Flash Hook

Sends a hook flash signal to the currently connected line if that line is an analog line.

**Action:** Advanced | Miscellaneous | Flash Hook.

**Action Data:** Optional. Normally this field is left blank. It can contain the destination number for a Centrex Transfer for external calls on a local analog line from a Centrex service provider. See [Centrex Transfer](#) on page 737.

**Default Label:** Flash or Flash Hook.

**Toggles:** No.

**Status Indication:** No.

**User Admin:** No.

**Phone Support** Note that support for particular phone models is also dependant on the system software level.

<b>Analog:</b> No	<b>20 Series:</b> Yes	<b>4100 Series:</b> No	<b>6400 Series:</b> Yes	<b>D100:</b> No
<b>1100 Series:</b> No	<b>2400 Series:</b> Yes [1]	<b>4400 Series:</b> Yes	<b>7400 Series:</b> No	<b>M-Series:</b> Yes
<b>1200 Series:</b> No	<b>3600 Series:</b> No	<b>4600 Series:</b> Yes [1]	<b>9040:</b> Yes	<b>T-Series:</b> Yes

*Table continues...*

<b>1400 Series:</b> Yes [1]	<b>3700 Series:</b> No	<b>5400 Series:</b> Yes	<b>9500 Series:</b> Yes	<b>T3/T3 IP Series:</b> No
<b>1600 Series:</b> Yes [1]	<b>3810:</b> Yes	<b>5600 Series:</b> Yes [1]	<b>9600 Series:</b> Yes	

1. Not 1403, 1603, 4601, 4602, 5601 and 5602 except where 4602 is supported on Release 2.1 and 3.0DT software.

## Follow Me Here

Causes calls to the extension number specified, to be redirected to this user's extension. User's with a log in code will be prompted to enter that code when using this function.

**Action:** Advanced | Follow Me | Follow Me Here.

**Action Data:** User name or user number.

If a user name or user number has been entered in the **Action Data** field, when the interactive menu opens, press `Enter` to activate Follow Me Here for the number displayed on the screen.

This field can be left blank for number entry when pressed.

On large display phones, if configured without a preset target, this type of button will display an interactive button menu for target selection.

**Default Label:** Here+ or Follow Me Here.

**Toggles:** No.

**Status Indication:** No.

**User Admin:** No.

**Phone Support** Note that support for particular phone models is also dependant on the system software level.

<b>Analog:</b> No	<b>20 Series:</b> Yes	<b>4100 Series:</b> No	<b>6400 Series:</b> Yes	<b>D100:</b> Yes
<b>1100 Series:</b> Yes	<b>2400 Series:</b> Yes [1]	<b>4400 Series:</b> Yes	<b>7400 Series:</b> No	<b>M-Series:</b> Yes
<b>1200 Series:</b> Yes	<b>3600 Series:</b> No	<b>4600 Series:</b> Yes [1]	<b>9040:</b> Yes	<b>T-Series:</b> Yes
<b>1400 Series:</b> Yes [1]	<b>3700 Series:</b> No	<b>5400 Series:</b> Yes	<b>9500 Series:</b> Yes	<b>T3/T3 IP Series:</b> No [2]
<b>1600 Series:</b> Yes [1]	<b>3810:</b> Yes	<b>5600 Series:</b> Yes [1]	<b>9600 Series:</b> Yes	

1. Not 1403, 1603, 4601, 4602, 5601 and 5602 except where 4602 is supported on Release 2.1 and 3.0DT software.

- Limited support on some specific T3 phone models as detailed below.

### T3 Phones:

- **Classic/Comfort icon:** Displays  followed by the user name.
- **DSS Link LED:** On when active.

---

## Follow Me Here Cancel

Cancels any 'Follow Me Here' set on the specified extension. Only works if entered at the extension to which the extension's calls are being sent by the follow me action.

**Action:** Advanced | Follow Me | Follow Me Here Cancel.

**Action Data:** User number or blank for number entry when pressed.

If a user name or user number has been entered in the **Action Data** field, when the interactive menu opens, press `Enter` to deactivate Follow Me Here for the number displayed on the screen.

On large display phones, if configured without a preset target, this type of button will display an interactive button menu for target selection.

**Default Label:** Here- or Follow Me Here-.

**Toggles:** No.

**Status Indication:** No.

**User Admin:** No.

**Phone Support** Note that support for particular phone models is also dependant on the system software level.

<b>Analog:</b> No	<b>20 Series:</b> Yes	<b>4100 Series:</b> No	<b>6400 Series:</b> Yes	<b>D100:</b> Yes
<b>1100 Series:</b> Yes	<b>2400 Series:</b> Yes [1]	<b>4400 Series:</b> Yes	<b>7400 Series:</b> No	<b>M-Series:</b> Yes
<b>1200 Series:</b> Yes	<b>3600 Series:</b> No	<b>4600 Series:</b> Yes [1]	<b>9040:</b> Yes	<b>T-Series:</b> Yes
<b>1400 Series:</b> Yes [1]	<b>3700 Series:</b> No	<b>5400 Series:</b> Yes	<b>9500 Series:</b> Yes	<b>T3/T3 IP Series:</b> No
<b>1600 Series:</b> Yes [1]	<b>3810:</b> Yes	<b>5600 Series:</b> Yes [1]	<b>9600 Series:</b> Yes	

- Not 1403, 1603, 4601, 4602, 5601 and 5602 except where 4602 is supported on Release 2.1 and 3.0DT software.

## Follow Me To

Leaving the extension blank prompts the user to enter the extension to which their calls should be redirected. User's with a log in code will be prompted to enter that code when using this function.

**Action:** Advanced | Follow Me | Follow Me To.

**Action Data:** User name or user number or blank for number entry when pressed.

If a user name or user number has been entered in the **Action Data** field, when the interactive menu opens, press `Enter` to activate Follow Me To for the number displayed on the screen.

On large display phones, if configured without a preset target, this type of button will display an interactive button menu for target selection.

**Default Label:** FolTo or Follow Me To.

**Toggles:** Yes.

**Status Indication:** Yes. On/off status indication is provided if the button is programmed with a user name or number.

Status	2400, 5400 Series	4600, 5600 Series	1400, 1600, 4400, 6400, 9500 Series	9600 Series	9608, 9611, J139, J159, J169, J179, J189	9621, 9641	T-Series, M-Series
- On.	<Label> ◀	<Label>	Green on	Red on	Green on	■ Green	▲ On
- Off.	<Label>	<Label>	Off	Off	Off	■ Grey	Off

**User Admin:** No.

**Phone Support** Note that support for particular phone models is also dependant on the system software level.

<b>Analog:</b> No	<b>20 Series:</b> Yes	<b>4100 Series:</b> No	<b>6400 Series:</b> Yes	<b>D100:</b> Yes
<b>1100 Series:</b> Yes	<b>2400 Series:</b> Yes [1]	<b>4400 Series:</b> Yes	<b>7400 Series:</b> No	<b>M-Series:</b> Yes
<b>1200 Series:</b> Yes	<b>3600 Series:</b> No	<b>4600 Series:</b> Yes [1]	<b>9040:</b> Yes	<b>T-Series:</b> Yes
<b>1400 Series:</b> Yes [1]	<b>3700 Series:</b> No	<b>5400 Series:</b> Yes	<b>9500 Series:</b> Yes	<b>T3/T3 IP Series:</b> No
<b>1600 Series:</b> Yes [1]	<b>3810:</b> Yes	<b>5600 Series:</b> Yes [1]	<b>9600 Series:</b> Yes	

1. Not 1403, 1603, 4601, 4602, 5601 and 5602 except where 4602 is supported on Release 2.1 and 3.0DT software.

## Forward Hunt Group Calls Off

Cancels the forwarding of the user's hunt group calls. This function is obsolete since the button function Forward Hunt Group Calls On toggles on/off and indicates status.

**Action:** Advanced | Forward | Forward Hunt Group Calls Off.

**Action Data:** None.

**Default Label:** FwdH-.

**Toggles:** No.

**Status Indication:** No.

User Admin: No.

**Phone Support** Note that support for particular phone models is also dependant on the system software level.

<b>Analog:</b> No	<b>20 Series:</b> Yes	<b>4100 Series:</b> No	<b>6400 Series:</b> Yes	<b>D100:</b> No
<b>1100 Series:</b> No	<b>2400 Series:</b> Yes [1]	<b>4400 Series:</b> Yes	<b>7400 Series:</b> No	<b>M-Series:</b> No
<b>1200 Series:</b> No	<b>3600 Series:</b> No	<b>4600 Series:</b> Yes [1]	<b>9040:</b> Yes	<b>T-Series:</b> No
<b>1400 Series:</b> Yes [1]	<b>3700 Series:</b> No	<b>5400 Series:</b> Yes	<b>9500 Series:</b> No	<b>T3/T3 IP Series:</b> No
<b>1600 Series:</b> Yes [1]	<b>3810:</b> Yes	<b>5600 Series:</b> Yes [1]	<b>9600 Series:</b> No	

1. Not 1403, 1603, 2402, 4601, 4602, 5601 and 5602 except where 4602 is supported on Release 2.1 and 3.0DT software.

## Forward Hunt Group Calls On

Forward the user's hunt group calls (internal and external). This function only works when forward unconditional is also on and uses the same forwarding number as forward unconditional.

This option is only applied for calls to **Sequential** and **Rotary** type hunt groups. Calls from other hunt group types are not presented to the user when they have Forward Unconditional active. Note also that hunt group calls cannot be forwarded to another hunt group.

**Action:** Advanced | Forward | Forward Hunt Group Calls On.

**Action Data:** None.

**Default Label:** FwdH+ or Fwd HG Calls.

**Toggles:** Yes.

**Status Indication:** Yes.

Status	2400, 5400 Series	4600, 5600 Series	1400, 1600, 4400, 6400, 9500 Series	9600 Series	9608, 9611, J139, J159, J169, J179, J189	9621, 9641	T-Series, M-Series
- On.	<Label> ◀	<Label>	Green on	Red on	Green on	■ Green	▲ On
- Off.	<Label>	<Label>	Off	Off	Off	■ Grey	Off

**User Admin:** No.

**Phone Support** Note that support for particular phone models is also dependant on the system software level.

Analog: ✗	20 Series: ✓	4100 Series: ✗	6400 Series: ✓	D100: ✗
1100 Series: ✗	2400 Series: ✓ [1]	4400 Series: ✓	7400 Series: ✗	M-Series: ✓
1200 Series: ✗	3600 Series: ✗	4600 Series: ✓ [1]	9040: ✓	T-Series: ✓
1400 Series: ✓ [1]	3700 Series: ✗	5400 Series: ✓	9500 Series: ✓	T3/T3 IP Series: ✗
1600 Series: ✓ [1]	3810: ✓	5600 Series: ✓ [1]	9600 Series: ✓	

1. Not 1403, 1603, 4601, 4602, 5601 and 5602 except where 4602 is supported on Release 2.1 and 3.0DT software.

---

## Forward Number

Sets the number to which calls are forwarded when the user has forwarding on. Used for all forwarding options unless a separate **Forward On Busy Number** is also set. Forwarding to an external number is blocked if **Inhibit Off-Switch Transfers** is selected within the system configuration.

- **Action:** Advanced | Forward | Forward Number.
- **Action Data:** Telephone number.
- The field to be left blank to prompt the user for entry when the button is pressed. If blank, users with a log in code will be prompted to enter that code.
- On large display phones, if configured without a preset target, this type of button will display an interactive button menu for target selection.
- **Default Label:** FwdNo or Fwd Number.
- **Toggles:** No.
- **Status Indication:** Yes. For a button with a prefixed number, status indication will indicate when that number matches the users current set number. For a button with a no number, status indication will show when a number has been set.

Status	2400, 5400 Series	4600, 5600 Series	1400, 1600, 4400, 6400, 9500 Series	9600 Series	9608, 9611, J139, J159, J169, J179, J189	9621, 9641	T-Series, M-Series
- On.	<Label> ◀	<Label>	Green on	Red on	Green on	■ Green	▲ On
- Off.	<Label>	<Label>	Off	Off	Off	■ Grey	Off

- **User Admin:** No.
- **Phone Support** Note that support for particular phone models is also dependant on the system software level.

Analog: ✗	20 Series: ✓	4100 Series: ✗	6400 Series: ✓	D100: ✗
1100 Series: ✗	2400 Series: ✓ [1]	4400 Series: ✓	7400 Series: ✗	M-Series: ✓
1200 Series: ✗	3600 Series: ✗	4600 Series: ✓ [1]	9040: ✓	T-Series: ✓
1400 Series: ✓ [1]	3700 Series: ✗	5400 Series: ✓	9500 Series: ✓	T3/T3 IP Series: ✗
1600 Series: ✓ [1]	3810: ✓	5600 Series: ✓ [1]	9600 Series: ✓	Vantage Connect Expansion: ✓

1. Not 1403, 1603, 4601, 4602, 5601 and 5602 except where 4602 is supported on Release 2.1 and 3.0DT software.

---

## Forward On Busy Number

Sets the number to which calls are forwarded when using 'Forward on Busy' and/or 'Forward on No Answer'. Forwarding to an external number is blocked if **Inhibit Off-Switch Transfers** is selected within the system configuration.

- **Action:** Advanced | Forward | Forward on Busy Number.
- **Action Data:** Telephone number.
  - The field to be left blank to prompt the user for entry when the button is pressed. If blank, users with a log in code will be prompted to enter that code.
  - On large display phones, if configured without a preset target, this type of button will display an interactive button menu for target selection.
- **Default Label:** FwBNo or Fwd Busy Number.
- **Toggles:** No.
- **Status Indication:** Yes. For a button with a prefixed number, status indication will indicate when that number matches the users current set number. For a button with a no number, status indication will show when a number has been set.

Status	2400, 5400 Series	4600, 5600 Series	1400, 1600, 4400, 6400, 9500 Series	9600 Series	9608, 9611, J139, J159, J169, J179, J189	9621, 9641	T-Series, M-Series
- On.	<Label> ◀	<Label>	Green on	Red on	Green on	■ Green	▲ On
- Off.	<Label>	<Label>	Off	Off	Off	■ Grey	Off

- **User Admin:** No.
- **Phone Support** Note that support for particular phone models is also dependant on the system software level.

Analog: ✗	20 Series: ✓	4100 Series: ✗	6400 Series: ✓	D100: ✗
1100 Series: ✗	2400 Series: ✓ [1]	4400 Series: ✓	7400 Series: ✗	M-Series: ✓
1200 Series: ✗	3600 Series: ✗	4600 Series: ✓ [1]	9040: ✓	T-Series: ✓
1400 Series: ✓ [1]	3700 Series: ✗	5400 Series: ✓	9500 Series: ✓	T3/T3 IP Series: ✗
1600 Series: ✓ [1]	3810: ✓	5600 Series: ✓ [1]	9600 Series: ✓	Vantage Connect Expansion: ✓

1. Not 1403, 1603, 4601, 4602, 5601 and 5602 except where 4602 is supported on Release 2.1 and 3.0DT software.

## Forward On Busy Off

Switches forward on busy off. This button function is obsolete, as Forward On Busy On can be used to switch forward on busy on/off and provides status indication.

**Action:** Advanced | Forward | Forward on Busy Off.

**Action Data:** None.

**Default Label:** FwBOf.

**Toggles:** No.

**Status Indication:** No.

**User Admin:** No.

**Phone Support** Note that support for particular phone models is also dependant on the system software level.

Analog: ✗	20 Series: ✓	4100 Series: ✗	6400 Series: ✓	D100: ✗
1100 Series: ✗	2400 Series: ✓ [1]	4400 Series: ✓	7400 Series: ✗	M-Series: ✗

*Table continues...*



1200 Series: ✗	3600 Series: ✗	4600 Series: ✓ [1]	9040: ✓	T-Series: ✗
1400 Series: ✓ [1]	3700 Series: ✗	5400 Series: ✓	9500 Series: ✗	T3/T3 IP Series: ✗
1600 Series: ✓ [1]	3810: ✓	5600 Series: ✓ [1]	9600 Series: ✗	

1. Not 1403, 1603, 2402, 4601, 4602, 5601 and 5602 except where 4602 is supported on Release 2.1 and 3.0DT software.

## Forward On Busy On

Enables forwarding when the user's extension is busy. For users with call appearance buttons, they will only return busy when all call appearance buttons are in use. Uses the **Forward Number** as its destination unless a separate **Forward on Busy Number** is set.

- **Forward Internal (User | Forwarding)** can also be used to control whether internal calls are forwarded.
- **Action:** Advanced | Forward | Forward on Busy On.
- **Action Data:** None.
- **Default Label:** FwBOn or Fwd Busy.
- **Toggles:** Yes.
- **Status Indication:** Yes.

Status	2400, 5400 Series	4600, 5600 Series	1400, 1600, 4400, 6400, 9500 Series	9600 Series	9608, 9611, J159, J169, J179, J189	9621, 9641	T-Series, M-Series
- On.	<Label> ◀	<Label>	Green on	Red on	Green on	■ Green	▲ On
- Off.	<Label>	<Label>	Off	Off	Off	■ Grey	Off

- **User Admin:** No.
- **Phone Support** Note that support for particular phone models is also dependant on the system software level.

Analog: ✗	20 Series: ✓	4100 Series: ✗	6400 Series: ✓	D100: ✗
1100 Series: ✗	2400 Series: ✓ [1]	4400 Series: ✓	7400 Series: ✗	M-Series: ✓
1200 Series: ✗	3600 Series: ✗	4600 Series: ✓ [1]	9040: ✓	T-Series: ✓
1400 Series: ✓ [1]	3700 Series: ✗	5400 Series: ✓	9500 Series: ✓	T3/T3 IP Series: ✗
1600 Series: ✓ [1]	3810: ✓	5600 Series: ✓ [1]	9600 Series: ✓	Vantage Connect Expansion: ✓

1. Not 1403, 1603, 4601, 4602, 5601 and 5602 except where 4602 is supported on Release 2.1 and 3.0DT software.

## Forward On No Answer Off

Switches forward on no answer off. This button function is obsolete, as Forward On No Answer On can be used to switch forward on no answer on/off and provides status indication.

**Action:** Advanced | Forward | Forward on No Answer Off.

**Action Data:** None.

**Default Label:** FwNOF.

**Toggles:** No.

**Status Indication:** No.

**User Admin:** No.

**Phone Support** Note that support for particular phone models is also dependant on the system software level.

Analog: ✗	20 Series: ✓	4100 Series: ✗	6400 Series: ✓	D100: ✗
1100 Series: ✗	2400 Series: ✓ [1]	4400 Series: ✓	7400 Series: ✗	M-Series: ✗
1200 Series: ✗	3600 Series: ✗	4600 Series: ✓ [1]	9040: ✓	T-Series: ✗
1400 Series: ✓ [1]	3700 Series: ✗	5400 Series: ✓	9500 Series: ✗	T3/T3 IP Series: ✗
1600 Series: ✓ [1]	3810: ✓	5600 Series: ✓ [1]	9600 Series: ✗	

1. Not 1403, 1603, 2402, 4601, 4602, 5601 and 5602 except where 4602 is supported on Release 2.1 and 3.0DT software.

## Forward On No Answer On

Switches forward on no answer on/off. The time used to determine the call as unanswered is the user's no answer time. Uses the **Forward Number** as its destination unless a separate **Forward on Busy Number** is set.

- **Forward Internal (User | Forwarding)** can also be used to control whether internal calls are forwarded.
- **Action:** Advanced | Forward | Forward on No Answer On.
- **Action Data:** None.
- **Default Label:** FwNOn or Fwd No Answer.
- **Toggles:** Yes.
- **Status Indication:** Yes.

Status	2400, 5400 Series	4600, 5600 Series	1400, 1600, 4400, 6400, 9500 Series	9600 Series	9608, 9611, J139, J159, J169, J179, J189	9621, 9641	T-Series, M-Series
- On.	<Label> ◀	<Label>	Green on	Red on	Green on	■ Green	▲ On
- Off.	<Label>	<Label>	Off	Off	Off	■ Grey	Off

- **User Admin:** No.

- **Phone Support** Note that support for particular phone models is also dependant on the system software level.

Analog: ✗	20 Series: ✓	4100 Series: ✗	6400 Series: ✓	D100: ✗
1100 Series: ✗	2400 Series: ✓ [1]	4400 Series: ✓	7400 Series: ✗	M-Series: ✓
1200 Series: ✗	3600 Series: ✗	4600 Series: ✓ [1]	9040: ✓	T-Series: ✓
1400 Series: ✓ [1]	3700 Series: ✗	5400 Series: ✓	9500 Series: ✓	T3/T3 IP Series: ✗
1600 Series: ✓ [1]	3810: ✓	5600 Series: ✓ [1]	9600 Series: ✓	Vantage Connect Expansion: ✓

1. Not 1403, 1603, 4601, 4602, 5601 and 5602 except where 4602 is supported on Release 2.1 and 3.0DT software.

---

## Forward Unconditional Off

Switch 'forward all calls' off. This does not affect 'Forward on No Answer' and/or 'Forward on Busy' if also on. This function is obsolete as a button set to Forward Unconditional On toggles on/off and indicates when on.

**Action:** Advanced | Forward | Forward Unconditional Off.

**Action Data:** None.

**Default Label:** FwUOf.

**Toggles:** No.

**Status Indication:** No.

**User Admin:** No.

**Phone Support** Note that support for particular phone models is also dependant on the system software level.

Analog: ✗	20 Series: ✓	4100 Series: ✗	6400 Series: ✓	D100: ✗
-----------	--------------	----------------	----------------	---------

*Table continues...*

1100 Series: ✗	2400 Series: ✔ [1]	4400 Series: ✔	7400 Series: ✗	M-Series: ✗
1200 Series: ✗	3600 Series: ✗	4600 Series: ✔ [1]	9040: ✔	T-Series: ✗
1400 Series: ✔ [1]	3700 Series: ✗	5400 Series: ✔	9500 Series: ✗	T3/T3 IP Series: ✗
1600 Series: ✔ [1]	3810: ✔	5600 Series: ✔ [1]	9600 Series: ✗	

1. Not 1403, 1603, 2402, 4601, 4602, 5601 and 5602 except where 4602 is supported on Release 2.1 and 3.0DT software.

## Forward Unconditional On

This function is also known as 'divert all' and 'forward all'. It forwards all calls, except hunt group and page calls, to the forward number set for the user's extension. To also forward hunt group calls to the same number 'Forward Hunt Group Calls On' must also be used.

- **Forward Internal (User | Forwarding)** can also be used to control whether internal calls are forwarded.
  - In addition to the lamp indication shown below, some phones display **D** when forward unconditional is on.
- **Action:** Advanced | Forward | Forward Unconditional On.
- **Action Data:** None.
- **Default Label:** FwUOn or Fwd Unconditional.
- **Toggles:** Yes.
- **Status Indication:** Yes.

Status	2400, 5400 Series	4600, 5600 Series	1400, 1600, 4400, 6400, 9500 Series	9600 Series	9608, 9611, J139, J159, J169, J179, J189	9621, 9641	T-Series, M-Series
- On.	<Label> ◀	<Label>	Green on	Red on	Green on	■ Green	▲ On
- Off.	<Label>	<Label>	Off	Off	Off	■ Grey	Off

**User Admin:** No.

**Phone Support** Note that support for particular phone models is also dependant on the system software level.

Analog: ✗	20 Series: ✔	4100 Series: ✗	6400 Series: ✔	D100: ✗
1100 Series: ✗	2400 Series: ✔ [1]	4400 Series: ✔	7400 Series: ✗	M-Series: ✔

*Table continues...*

1200 Series: ✗	3600 Series: ✗	4600 Series: ✓ [1]	9040: ✓	T-Series: ✓
1400 Series: ✓ [1]	3700 Series: ✗	5400 Series: ✓	9500 Series: ✓	T3/T3 IP Series: ✗ [2]
1600 Series: ✓ [1]	3810: ✓	5600 Series: ✓ [1]	9600 Series: ✓	Vantage Connect Expansion: ✓

1. Not 1403, 1603, 4601, 4602, 5601 and 5602 except where 4602 is supported on Release 2.1 and 3.0DT software.
2. Limited support on some specific T3 phone models as detailed below.

#### T3 Phones:

- **Classic/Comfort icon:** Displays  followed by the user name.
- **DSS Link LED:** On when active.

M-Series/T-Series: The button is equivalent to **Feature 4 <number>**.

---

## Group

Monitors the status of a hunt group queue. This option is only supported for hunt groups with queuing enabled. The user does not have to be a member of the group.

Depending on the users button type, indication is given for when the group has alerting calls and queued calls (queued in this case is defined as more calls waiting than there are available group members).

Pressing a **Group** button answers the longest waiting call.

The definition of queued calls include group calls that are ringing. However, for operation of the **Group** button, ringing calls are separate from other queued calls.

**Action:** Group.

**Action Data:** Group name enclosed in " " double-quotes or group number.

**Default Label:** <group name>.

**Toggles:** No.

**Status Indication:** Yes, Required.

<b>Status</b>	<b>2400, 5400 Series</b>	<b>4600, 5600 Series</b>	1400, 1600, 4400, 6400, 9500 Series	9600 Series	9608, 9611, J139, J159, J169, J179, J189	9621, 9641	<b>T-Series, M-Series</b>
---------------	--------------------------	--------------------------	-------------------------------------	-------------	------------------------------------------	------------	---------------------------

*Table continues...*

- No calls	Main	Main	Off	Off	Off	Grey	Off
- Call alerting	Main ◆	Main ◆	Green flash	Red flash	Green flash	Blue	Slow flash
- Calls queued	Main	Main	Red flash	Red on	Red flash	Green	Slow flash

User Admin: No.

**Phone Support** Note that support for particular phone models is also dependant on the system software level.

Analog: No	20 Series: Yes	4100 Series: No	6400 Series: Yes	D100: No
1100 Series: No	2400 Series: Yes [1]	4400 Series: Yes	7400 Series: No	M-Series: Yes
1200 Series: No	3600 Series: Yes	4600 Series: Yes [1]	9040: Yes	T-Series: Yes
1400 Series: Yes [1]	3700 Series: No	5400 Series: Yes	9500 Series: Yes	T3/T3 IP Series: No
1600 Series: Yes [1]	3810: Yes	5600 Series: Yes [1]	9600 Series: Yes	

1. Not 1403, 1603, 4601, 4602, 5601 and 5602 except where 4602 is supported on Release 2.1 and 3.0DT software.

---

## Group Listen On

Using group listen allows callers to be heard through the phone's handsfree speaker but to only hear the phone's handset microphone. This enables listeners at the user's phone to hear the connected party whilst limiting the connected party to hear only what is communicated via the phone handset

When group listen is enabled, it modifies the handsfree functionality of the user's phone in the following manner

When the user's phone is placed in handsfree/speaker mode, the speech path from the connected party is broadcast on the phone speaker but the phone's base microphone is disabled.

The connected party can only hear speech delivered via the phone's handset microphone.

Group listen is not supported for IP phones or when using a phone's **HEADSET** button.

For T-Series and M- Series phones, this option can be turned on or off during a call. For other phones, currently connected calls are not affected by changes to this setting, instead group listen must be selected before the call is connected.

Group listen is automatically turned off when the call is ended.

**Action:** Advanced | Extension | Group Listen On.

**Action Data:** None.

**Default Label:** Group Listen On.

**Toggles:** Yes.

**Status Indication:** Yes.

Status	2400, 5400 Series	4600, 5600 Series	1400, 1600, 4400, 6400, 9500 Series	9600 Series	9608, 9611, J139, J159, J169, J179, J189	9621, 9641	T-Series, M-Series
- On.	<Label> ◀	<Label>	Green on	Red on	Green on	■ Green	▲ On
- Off.	<Label>	<Label>	Off	Off	Off	■ Grey	Off

**User Admin:** No.

Phone Support Note that support for particular phone models is also dependant on the system software level.

Analog: ✗	20 Series: ✗	4100 Series: ✗	6400 Series: ✓	96x1 Series: ✓
1100 Series: ✗	2400 Series: ✓	4400 Series: ✓	7400 Series: ✗	D100: ✗
1200 Series: ✗	3600 Series: ✗	4600 Series: ✓	9040: ✗	M-Series: ✓ [2]
1400 Series: ✓ [1]	3700 Series: ✗	5400 Series: ✓	9500 Series: ✓	T-Series: ✓ [2]
1600 Series: ✓	3810: ✗	5600 Series: ✓	9600 Series: ✗	T3/T3 IP Series: ✗

1. Not 1403.
2. M-Series/T-Series: The button is equivalent to **Feature 802** (On) and **Feature #802** (Off).

---

## Group Paging

Makes a paging call to an extension or group specified. If no number is specified, this can be dialed after pressing the button. The target extension or group members must be free and must support handsfree auto-answer in order to hear the page.

On Avaya phones, a paged user can convert the page call into a normal call by pressing the **Conference** button.

**Action:** Emulation | Group Paging.

**Action Data:** User number or name or group number or name.

On large display phones, if configured without a preset target, this type of button will display an interactive button menu for target selection.

**Default Label:** GrpPg.

**Toggles:** No.

**Status Indication:** Yes.

**User Admin:** Yes.

**Phone Support** Note that support for particular phone models is also dependant on the system software level.

<b>Analog:</b> No	<b>20 Series:</b> Yes	<b>4100 Series:</b> No	<b>6400 Series:</b> Yes	<b>D100:</b> Yes
<b>1100 Series:</b> Yes	<b>2400 Series:</b> Yes [1]	<b>4400 Series:</b> Yes	<b>7400 Series:</b> No	<b>M-Series:</b> Yes
<b>1200 Series:</b> Yes	<b>3600 Series:</b> No	<b>4600 Series:</b> Yes [1]	<b>9040:</b> Yes	<b>T-Series:</b> Yes
<b>1400 Series:</b> Yes [1]	<b>3700 Series:</b> No	<b>5400 Series:</b> Yes	<b>9500 Series:</b> ✓	<b>T3/T3 IP Series:</b> No [2]
<b>1600 Series:</b> Yes [1]	<b>3810:</b> Yes	<b>5600 Series:</b> Yes [1]	<b>9600 Series:</b> Yes	

1. Not 1403, 1603, 4601, 4602, 5601 and 5602 except where 4602 is supported on Release 2.1 and 3.0DT software.
2. Limited support on some specific T3 phone models as detailed below.

**T3 Phones:**

- **Classic/Comfort icon:** Displays  followed by target number if set.
- **DSS Link LED:** None.

M-Series/T-Series: The button is equivalent to **Feature 60 <number>**.

## Headset Toggle

This function is intended for use with Avaya phones that have separate handset and headset sockets but do not provide a dedicated Headset button, for example older style 4400 Series and 4600 Series phones. On phones without a headset socket or with a dedicated headset button this control will have no effect.

**Action:** Miscellaneous | Headset Toggle.

**Action Data:** None.

**Default Label:** HdSet.

**Toggles:** Yes.

**Status Indication:** Yes.

**User Admin:** No.



Phone Support Note that support for particular phone models is also dependant on the system software level.

Analog: ✗	3600 Series: ✗	4600 Series: ✓ [1]	9040: ✗	T3/T3 IP Series: ✓ [2]
1400 Series: ✗	3700 Series: ✗	5400 Series: ✗	9500 Series: ✗	
1600 Series: ✗	3810: ✗	5600 Series: ✗	9600 Series: ✗	
20 Series: ✗	4100 Series: ✗	6400 Series: ✗	M-Series: ✗	
2400 Series: ✗	4400 Series: ✓	7400 Series: ✗	T-Series: ✗	

1. 4606, 4612 and 4624 only.
2. T3 Phones
  - **Classic/Comfort icon:** Displays HdSet.
  - **DSS Link LED:** On when active.

:

---

## Hold Call

This uses the Q.931 Hold facility, and "holds" the incoming call at the ISDN exchange, freeing up the ISDN B channel. The Hold Call feature "holds" the current call to a slot. The current call is always automatically placed into slot 0 if it has not been placed in a specified slot. Only available if supported by the ISDN exchange.

**Action:** Advanced | Hold | Hold Call.

**Action Data:** ISDN Exchange hold slot number or blank (slot 0).

**Default Label:** Hold.

**Toggles:** No.

**Status Indication:** No.

**User Admin:** No.

**Phone Support** Note that support for particular phone models is also dependant on the system software level.

Analog: ✗	20 Series: ✓	4100 Series: ✗	6400 Series: ✓	D100: ✗
1100 Series: ✗	2400 Series: ✓ [1]	4400 Series: ✓	7400 Series: ✗	M-Series: ✗
1200 Series: ✗	3600 Series: ✗	4600 Series: ✓ [1]	9040: ✓	T-Series: ✗
1400 Series: ✓ [1]	3700 Series: ✗	5400 Series: ✓	9500 Series: ✗	T3/T3 IP Series: ✗

*Table continues...*

1600 Series: ✓ [1]	3810: ✓	5600 Series: ✓ [1]	9600 Series: ✗	
--------------------	---------	--------------------	----------------	--

1. Not 1403, 1603, 2402, 4601, 4602, 5601 and 5602 except where 4602 is supported on Release 2.1 and 3.0DT software.

## Hold CW

Place the user's current call on hold and answers the waiting call. This function is not supported on phones which have multiple call appearance buttons set.

**Action:** Advanced | Hold | Hold CW.

**Action Data:** None.

**Default Label:** HoldCW.

**Toggles:** No.

**Status Indication:** No.

**User Admin:** No.

**Phone Support** Note that support for particular phone models is also dependant on the system software level.

Analog: ✗	20 Series: ✓	4100 Series: ✗	6400 Series: ✓	D100: ✗
1100 Series: ✗	2400 Series: ✓ [1]	4400 Series: ✓	7400 Series: ✗	M-Series: ✗
1200 Series: ✗	3600 Series: ✗	4600 Series: ✓ [1]	9040: ✓	T-Series: ✗
1400 Series: ✓ [1]	3700 Series: ✗	5400 Series: ✓	9500 Series: ✗	T3/T3 IP Series: ✗
1600 Series: ✓ [1]	3810: ✓	5600 Series: ✓ [1]	9600 Series: ✗	

1. Not 1403, 1603, 2402, 4601, 4602, 5601 and 5602 except where 4602 is supported on Release 2.1 and 3.0DT software.

## Hold Music

This feature allows the user to listen to the system's music on hold. See Music On Hold for more information.

**Action:** Advanced | Hold | Hold Music.

**Action Data:** Optional. Systems can support multiple hold music sources. However only the system source is supported for **Hold Music** buttons.

**Default Label:** Music or Hold Music.

**Toggles:** No.

**Status Indication:** No.

**User Admin:** No.

**Phone Support** Note that support for particular phone models is also dependant on the system software level.

<b>Analog:</b> ✗	<b>20 Series:</b> ✓	<b>4100 Series:</b> ✗	<b>6400 Series:</b> ✓	<b>D100:</b> ✗
<b>1100 Series:</b> ✗	<b>2400 Series:</b> ✓ [1]	<b>4400 Series:</b> ✓	<b>7400 Series:</b> ✗	<b>M-Series:</b> ✓
<b>1200 Series:</b> ✗	<b>3600 Series:</b> ✗	<b>4600 Series:</b> ✓ [1]	<b>9040:</b> ✓	<b>T-Series:</b> ✓
<b>1400 Series:</b> ✓ [1]	<b>3700 Series:</b> ✗	<b>5400 Series:</b> ✓	<b>9500 Series:</b> ✓	<b>T3/T3 IP Series:</b> ✗
<b>1600 Series:</b> ✓ [1]	<b>3810:</b> ✓	<b>5600 Series:</b> ✓ [1]	<b>9600 Series:</b> ✓	

1. Not 1403, 1603, 4601, 4602, 5601 and 5602 except where 4602 is supported on Release 2.1 and 3.0DT software.

## Hunt Group Enable

An individual users membership of any particular hunt groups is programmed through the system configuration. This control allows the user to enable or disable that membership. While enabled, the user can receive hunt group calls when logged in.

- In addition to the lamp indication below, phones display **G** when any group membership is enabled.
- **Action:** Advanced | Hunt Group | Hunt Group Enable.
- **Action Data:** Group number or name or blank for all groups of which the user is a member.
- **Default Label:** HGE na or HG Enable.
- **Toggles:** Yes.
- **Status Indication:** Yes. Required.

Status	2400, 5400 Series	4600, 5600 Series	1400, 1600, 4400, 6400, 9500 Series	9600 Series	9608, 9611, J139, J159, J169, J179, J189	9621, 9641	T-Series, M-Series
- On.	<Label> ◀	<Label>	Green on	Red on	Green on	■ Green	▲ On
- Off.	<Label>	<Label>	Off	Off	Off	■ Grey	Off

- **User Admin:** No.
- **Phone Support** Note that support for particular phone models is also dependant on the system software level.

Analog: ✗	20 Series: ✓	4100 Series: ✗	6400 Series: ✓	D100: ✗
1100 Series: ✗	2400 Series: ✓ [1]	4400 Series: ✓	7400 Series: ✗	M-Series: ✓
1200 Series: ✗	3600 Series: ✗	4600 Series: ✓ [1]	9040: ✓	T-Series: ✓
1400 Series: ✓ [1]	3700 Series: ✗	5400 Series: ✓	9500 Series: ✓	T3/T3 IP Series: ✗ [2]
1600 Series: ✓ [1]	3810: ✓	5600 Series: ✓ [1]	9600 Series: ✓	Vantage Connect Expansion: ✓

1. Not 1403, 1603, 4601, 4602, 5601 and 5602 except where 4602 is supported on Release 2.1 and 3.0DT software.
2. Limited support on some specific T3 phone models as detailed below.

**T3 Phones:**

- **Classic/Comfort icon:** Displays **[#]** followed by the group number or \* for all if programmed with no specific group number.
- **DSS Link LED:** On when active.

## Hunt Group Disable

This function is obsolete, the Hunt Group Enable function being able to toggle membership between enabled and disabled and providing lamp indication of when membership is enabled.

An individual user's membership of any particular hunt groups is programmed through the system configuration. This control allows the user to disable that membership. They will no longer receive calls to that hunt group until their membership is enabled again.

**Action:** Advanced | Hunt Group | Hunt Group Disable.

**Action Data:** Group number or blank for all groups of which the user is a member.

**Default Label:** HGDIs.

**Toggles:** No.

**Status Indication:** No.

**User Admin:** No.

**Phone Support** Note that support for particular phone models is also dependant on the system software level.

Analog: ✗	20 Series: ✓	4100 Series: ✗	6400 Series: ✓	D100: ✗
1100 Series: ✗	2400 Series: ✓ [1]	4400 Series: ✓	7400 Series: ✗	M-Series: ✗
1200 Series: ✗	3600 Series: ✗	4600 Series: ✓ [1]	9040: ✓	T-Series: ✗
1400 Series: ✓ [1]	3700 Series: ✗	5400 Series: ✓	9500 Series: ✗	T3/T3 IP Series: ✗

*Table continues...*

1600 Series: ✓ [1]	3810: ✓	5600 Series: ✓ [1]	9600 Series: ✗	
--------------------	---------	--------------------	----------------	--

1. Not 1403, 1603, 2402, 4601, 4602, 5601 and 5602 except where 4602 is supported on Release 2.1 and 3.0DT software.

---

## Inspect

Not supported. Provided for CTI emulation only. Allows users on display phones to determine the identification of held calls. Allows users on an active call to display the identification of incoming calls.

**Action:** Emulation | Inspect.

**Action Data:** None.

**Default Label:** Inspt.

**Toggles:** No.

**Status Indication:** No.

**User Admin:** No.

**Phone Support** Note that support for particular phone models is also dependant on the system software level.

Analog: ✗	20 Series: ✓	4100 Series: ✗	6400 Series: ✓	D100: ✗
1100 Series: ✗	2400 Series: ✓ [1]	4400 Series: ✓	7400 Series: ✗	M-Series: ✗
1200 Series: ✗	3600 Series: ✗	4600 Series: ✓ [1]	9040: ✓	T-Series: ✗
1400 Series: ✓ [1]	3700 Series: ✗	5400 Series: ✓	9500 Series: ✗	T3/T3 IP Series: ✗
1600 Series: ✓ [1]	3810: ✓	5600 Series: ✓ [1]	9600 Series: ✗	

1. Not 1403, 1603, 2402, 4601, 4602, 5601 and 5602 except where 4602 is supported on Release 2.1 and 3.0DT software.

---

## Internal Auto-Answer

This function is also known as handsfree auto-answer. It sets the user's extension to automatically connect internal calls after a single tone. This function should only be used on phones that support handsfree operation.

**Action:** Emulation | Internal Auto-Answer.

**Action Data:** Optional.

- If left blank this function acts as described above for internal auto-answer.

- **FF** can be entered. In that case the button will enable/disable headset force feed operation for external calls. In this mode, when headset mode is selected but the phone is idle, an incoming external call will cause a single tone and then be automatically connected. This operation is only supported on Avaya phones with a fixed **HEADSET** button. Ring delay is applied if set on the appearance button receiving the call before the call is auto-connected.

**Default Label:** HFAnS or Auto Answer.

**Toggles:** Yes.

**Status Indication:** Yes. Required.

Status	2400, 5400 Series	4600, 5600 Series	1400, 1600, 4400, 6400, 9500 Series	9600 Series	9608, 9611, J139, J159, J169, J179, J189	9621, 9641	T-Series, M-Series
- On.	<Label> ◀	<Label>	Green on	Red on	Green on	■ Green	▲ On
- Off.	<Label>	<Label>	Off	Off	Off	■ Grey	Off

**User Admin:** Yes.

**Phone Support** Note that support for particular phone models is also dependant on the system software level.

Analog: ✗	20 Series: ✓	4100 Series: ✗	6400 Series: ✓	D100: ✗
1100 Series: ✗	2400 Series: ✓ [1]	4400 Series: ✓	7400 Series: ✗	M-Series: ✓
1200 Series: ✗	3600 Series: ✗	4600 Series: ✓ [1]	9040: ✓	T-Series: ✓
1400 Series: ✓ [1]	3700 Series: ✗	5400 Series: ✓	9500 Series: ✓	T3/T3 IP Series: ✗ [2]
1600 Series: ✓ [1]	3810: ✓	5600 Series: ✓ [1]	9600 Series: ✓	

1. Not 1403, 1603, 4601, 4602, 5601 and 5602 except where 4602 is supported on Release 2.1 and 3.0DT software.
2. Limited support on some specific T3 phone models as detailed below.

**T3 Phones:**

- **Classic/Comfort icon:** Displays **HFAnS**.
- **DSS Link LED:** On when active.

## Last Number Redial

This function is intend for use with Avaya M-Series and T-Series phones only. When pressed, the button invokes the same last number redial process as dialing **Feature 5**.

**Action:** Advanced | Call | Last Number Redial.

**Action Data:** None.

**Default Label:** Again.

**Toggles:** No.

**Status Indication:** No.

**User Admin:** No.

**Phone Support** This function is only supported on Avaya M-Series and T-Series phones.

M-Series/T-Series: The button is equivalent to **Feature 5**.

## Leave Word Calling

Not supported. Provided for CTI emulation only. Leaves a message for the user associated with the last number dialed to call the originator.

**Action:** Emulation | Leave Word Calling.

**Action Data:** None.

**Default Label:** LWC.

**Toggles:** No.

**Status Indication:** No.

**User Admin:** No.

**Phone Support** Note that support for particular phone models is also dependant on the system software level.

<b>Analog:</b> ✗	<b>20 Series:</b> ✓	<b>4100 Series:</b> ✗	<b>6400 Series:</b> ✓	<b>D100:</b> ✗
<b>1100 Series:</b> ✗	<b>2400 Series:</b> ✓ [1]	<b>4400 Series:</b> ✓	<b>7400 Series:</b> ✗	<b>M-Series:</b> ✗
<b>1200 Series:</b> ✗	<b>3600 Series:</b> ✗	<b>4600 Series:</b> ✓ [1]	<b>9040:</b> ✓	<b>T-Series:</b> ✗
<b>1400 Series:</b> ✓ [1]	<b>3700 Series:</b> ✗	<b>5400 Series:</b> ✓	<b>9500 Series:</b> ✗	<b>T3/T3 IP Series:</b> ✗
<b>1600 Series:</b> ✓ [1]	<b>3810:</b> ✓	<b>5600 Series:</b> ✓ [1]	<b>9600 Series:</b> ✗	

1. Not 1403, 1603, 2402, 4601, 4602, 5601 and 5602 except where 4602 is supported on Release 2.1 and 3.0DT software.

## Line Appearance

Creates an line appearance button linked to the activity of a specified line appearance ID number. The button can then be used to answer and make calls on that line.

The line appearance button user must also have at least one call appearance button programmed before line appearance buttons can be programmed.

Line appearance functions, assigned to buttons that do not have status lamps or icons, are automatically disabled until the user logs in at a phone with suitable buttons.

Release 3.2+: Appearance buttons can be set with a ring delay if required or to not ring. This does not affect the visual alerting displayed next to the button. The delay uses the user's Ring Delay (User | Telephony | Multi-line Options) setting.

Release 4.2+: Line appearances are supported on T3 and T3 IP phones. These phones do not require (or support) call appearance buttons in order to use line appearances.

**Action:** Appearance | Line Appearance.

**Action Data:** Line ID number.

**Default Label:** Line <Line ID number>.

**Toggles:** No.

**Status Indication:** Yes. See Line Appearance Button Indication.

**User Admin:** No.

**Phone Support:** The following table indicates phones which support the programmable button:

Analog: ✗	20 Series: ✗	4100 Series: ✗	6400 Series: ✓	D100: ✗
1100 Series: ✗	2400 Series: ✓	4400 Series: ✓	7400 Series: ✗	M-Series: ✓ [1]
1200 Series: ✗	3600 Series: ✓	4600 Series: ✓	9040: ✓	T-Series: ✓ [1]
1400 Series: ✓	3700 Series: ✗	5400 Series: ✓	9500 Series: ✓	T3/T3 IP Series: ✗
1600 Series: ✓	3810: ✓	5600 Series: ✓	9600 Series: ✓	

1. Not supported on T7000, T7100, M7100, M7100N and the Audio Conferencing Unit (ACU).

## MADN Call Appearance

Multiple Appearance Directory Number (MADN) emulates an Avaya Communication Server 1000 key and lamp style feature.

When using normal appearance buttons to answer or make calls, the information (name and number) presented to the other end of the call is that of the button user (subject to any other line and short code settings). When using a MADN call appearance button, the information presented is that of the user to which the button is associated rather than that of the button user.



The user associated with a MADN button does not need to have a license or an active extension. However, they must have an extension number. The system considers the user's records when the user makes a call using the MADN buttons. You can have up to 30 MADN buttons associated with the same user.

MADN can operate in two modes:

- **MADN Single Call Appearance (SCA)**

The button is configured with the user name of the associated user and one of their call appearances. This provides the following behaviors:

- Incoming extension calls: The button acts like a Bridged Appearance button to the associated user.
- Incoming group calls: The button alerts if associated user is a member of the hunt group and alerting.
- Outgoing calls: The button acts like a Call Appearance. It presents the call as originating from the button user but with the number and name of the associated user in the calling party information.

- **MADN Multiple Call Appearance (MCA)**

The button is configured with just the user name of the associated user. This provides the following behaviors:

- Incoming extension calls: The button acts like a Coverage Appearance to the associated user.
- Incoming groups calls: The button does not alert.
- Outgoing calls: The button acts like a Call Appearance. It presents the call as originating from the button user but with the number of the associated user in the calling party information.

**Action** Either:

- Appearance | MADN Single Call Appearance
- Appearance | MADN Multiple Call Appearance

**Action Data:**

- MADN Single Call Appearance: User Name, Call Appearance button number and Ring Delay.
- MADN Multiple Call Appearance: User Name and Ring Delay.

**Default Label:**

- MADN SCA: <MADN number S=>
- MADN MCA: <MADN number M=>

**Toggles:** No.

**Status Indication:**

- MADN SCA: Yes. See Bridge Appearance Button Indication.

- MADN MCA: Yes. See Coverage Button Indication.

**User Admin:** No.

**Phone Support:** The following table indicates phones which support the programmable button:

Analog: ✗	20 Series: ✗	4100 Series: ✗	6400 Series: ✗	D100: ✗
1100 Series: ✗	2400 Series: ✗	4400 Series: ✗	7400 Series: ✗	M-Series: ✗
1200 Series: ✗	3600 Series: ✗	4600 Series: ✗	9040: ✗	T-Series: ✗
1400 Series: ✓	3700 Series: ✗	5400 Series: ✗	9500 Series: ✓	T3/T3 IP Series: ✗
1600 Series: ✓	3810: ✗	5600 Series: ✗	9600 Series: ✓	

## Manual Exclude

Not supported. Provided for CTI emulation only.

**Action:** Emulation | Manual Exclude

**Action Data:** None.

**Default Label:** Excl.

**Toggles:** No.

**Status Indication:** No.

**User Admin:** No.

**Phone Support:** Note that support for particular phone models is also dependant on the system software level.

Analog: No	20 Series: Yes	4100 Series: No [1]	64000: Yes	D100: No
1100 Series: No	2400 Series: Yes	4400 Series: Yes	7400 Series: No	M-Series: No
1200 Series: No	3600 Series: No	4600 Series: Yes [1]	9040 Series: Yes	T-Series: No
1400 Series: Yes [1]	3700 Series: No	5400 Series: Yes	9500 Series: No	T3/T3 IP Series: No
1600 Series: Yes [1]	3810 Series: Yes	5600 Series: Yes [1]	9600 Series: No	

1. Not 1403, 1603, 2402, 4601, 4602, 5601 and 5602 except where 4602 is supported on Release 2.1 and 3.0DT software.

## MCID Activate

This action is used with ISDN Malicious Caller ID call tracing. It is used to trigger a call trace at the ISDN exchange. The call trace information is then provided to the appropriate legal authorities.

This option requires the line to the ISDN to have MCID enabled at both the ISDN exchange and on the system. The user must also be configured with **Can Trace Calls (User | Telephony | Supervisor Settings)** enabled.

 **Note:**

Currently, in Server Edition network, MCID is only supported for users using an MCID button and registered on the same IP500 V2 Expansion system as the MCID trunks.

**Action:** Advanced | Miscellaneous | MCID Activate.

**Action Data:** None.

**Default Label:** MCID or Malicious Call.

**Toggles:** No.

**Status Indication:** Yes.

**User Admin:** No.

**Phone Support:** Note that support for particular phone models is also dependant on the system software level.

<b>Analog:</b> No	<b>3600 Series:</b> No	<b>4600 Series:</b> Yes [1]	<b>9040:</b> Yes	<b>T3/T3 IP Series:</b> No
<b>1400 Series:</b> Yes	<b>3700 Series:</b> No	<b>5400 Series:</b> Yes	<b>9500 Series:</b> Yes	
<b>1600 Series:</b> Yes [1]	<b>3810:</b> Yes	<b>5600 Series:</b> Yes [1]	<b>9600 Series:</b> Yes	
<b>20 Series:</b> No	<b>4100 Series:</b> No	<b>6400 Series:</b> No	<b>M-Series:</b> Yes	
<b>2400 Series:</b> Yes	<b>4400 Series:</b> Yes	<b>7400 Series:</b> No	<b>T-Series:</b> Yes	

1. Not 1603, 4601, 4602, 5601 and 5602.

## Monitor Analogue Trunk MWI

Enables a user to receive message waiting indicator (MWI) signals from analog trunks terminating on the ATM4U-V2 card. MWI is a telephone feature that turns on a visual indicator on a telephone when there are recorded messages.

**Action:** Advanced | Voicemail | Monitor Analogue Trunk MWI.

**Action Data:** The line appearance ID of the analog line for which MWI will be received.

**Default Label:** Trunk MWI.

**Toggles:** No.

**Status Indication:** No.

**User Admin:** No.

## Off Hook Station

Enables the user's extension to be controlled by an application, for example SoftConsole. Calls can then be answered and cleared through the application without having to manually go off or on hook. Requires the phone to support full handsfree operation.

**Action:** Advanced | Miscellaneous | Off Hook Station.

**Action Data:** None.

**Default Label:** OHStn.

**Toggles:** Yes.

**Status Indication:** Yes.

Status	2400, 5400 Series	4600, 5600 Series	1400, 1600, 4400, 6400, 9500 Series	9600 Series	9608, 9611, J139, J159, J169, J179, J189	9621, 9641	T-Series, M-Series
- On.	<Label> ◀	<Label>	Green on	Red on	Green on	■ Green	▲ On
- Off.	<Label>	<Label>	Off	Off	Off	■ Grey	Off

**User Admin:** No.

Phone Support Note that support for particular phone models is also dependant on the system software level.

Analog: ✗	3600 Series: ✗	4600 Series: ✔ [1]	9040: ✔	T3/T3 IP Series: ✗
1400 Series: ✔	3700 Series: ✗	5400 Series: ✔ [1]	9500 Series: ✔	
1600 Series: ✔	3810: ✔	5600 Series: ✔ [1]	9600 Series: ✔	
20 Series: ✔	4100 Series: ✗	6400 Series: ✔	M-Series: ✔	
2400 Series: ✔ [1]	4400 Series: ✔	7400 Series: ✗	T-Series: ✔	

1. Not 2402, 4601, 4602, 5402, 5601 and 5602 models.

## Pause Recording

This feature can be used to pause any call recording. It can be used during a call that is being recorded to omit sensitive information such as customer credit card information. This feature can be used with calls that are recorded both manually or calls that are recorded automatically.

The button status indicates when call recording has been paused. The button can be used to restart call recording. The system **Auto Restart Paused Recording** (System | Voicemail) setting can be used to set a delay after which recording is automatically resumed.

If the voicemail system is configured to provide advice of call recording warnings, then pausing the recording will trigger a "Recording paused" prompt and a repeat of the advice of call recording warning when recording is resumed.

**Action:** Advanced | Call | Pause Recording.

**Action Data:** None.

**Default Label:** PauseRec or Pause Recording.

**Toggles:** Yes.

**Status Indication:** Yes.

**User Admin:** No.

**Phone Support** Note that support for particular phone models is also dependant on the system software level.

Analog: ✗	20 Series: ✗	4100 Series: ✗	6400 Series: ✗	D100: ✗
1100 Series: ✗	2400 Series: ✗	4400 Series: ✗	7400 Series: ✗	M-Series: ✗
1200 Series: ✗	3600 Series: ✗	4600 Series: ✗	9040: ✗	T-Series: ✗
1400 Series: ✓ [1]	3700 Series: ✗	5400 Series: ✗	9500 Series: ✓	T3/T3 IP Series: ✗
1600 Series: ✓ [1]	3810: ✗	5600 Series: ✗	9600 Series: ✓	

1. Not 1403, 1603.

## Priority Call

This feature allows the user to call another user even if they are set to 'do not disturb'. A priority call will follow forward and follow me settings but will not go to voicemail.

- **Action:** Advanced | Call | Priority Call.
- **Action Data:** User number or name.
- **Default Label:** PCall or Priority Call.
- **Toggles:** No.

- **Status Indication:** No.
- **User Admin:** No.
- **Phone Support:** The following table indicates phones which support the programmable button:

Analog: ✗	20 Series: ✔	4100 Series: ✗	6400 Series: ✔	D100: ✗
1100 Series: ✗	2400 Series: ✔ [1]	4400 Series: ✔	7400 Series: ✗	M-Series: ✔
1200 Series: ✗	3600 Series: ✗	4600 Series: ✔ [1]	9040: ✔	T-Series: ✔
1400 Series: ✔ [1]	3700 Series: ✗	5400 Series: ✔	9500 Series: ✔	T3/T3 IP Series: ✗
1600 Series: ✔ [1]	3810: ✔	5600 Series: ✔ [1]	9600 Series: ✔	Vantage Connect Expansion: ✔

1. Not 1403, 1603, 4601, 4602, 5601 and 5602 except where 4602 is supported on Release 2.1 and 3.0DT software.

## Priority Calling

Not supported. Provided for CTI emulation only.

**Action:** Emulation | Priority Calling.

**Action Data:** None.

**Default Label:** Pcall.

**Toggles:** No.

**Status Indication:** No.

**Phone Support:** The following table indicates phones which support the programmable button:

Analog: ✗	20 Series: ✔	4100 Series: ✗	6400 Series: ✔	D100: ✗
1100 Series: ✗	2400 Series: ✔ [1]	4400 Series: ✔	7400 Series: ✗	M-Series: ✗
1200 Series: ✗	3600 Series: ✗	4600 Series: ✔ [1]	9040: ✔	T-Series: ✗
1400 Series: ✔ [1]	3700 Series: ✗	5400 Series: ✔	9500 Series: ✗	T3/T3 IP Series: ✗
1600 Series: ✔ [1]	3810: ✔	5600 Series: ✔ [1]	9600 Series: ✗	

1. Not 1403, 1603, 2402, 4601, 4602, 5601 and 5602 except where 4602 is supported on Release 2.1 and 3.0DT software.

## Private Call

When on, any subsequent calls cannot be intruded on until the user's private call status is switched off. The exception is Whisper Page which can be used to talk to a user on a private call.

Note that use of private calls is separate from the user's intrusion settings. If the user's **Cannot be Intruded** (User | Telephony | Supervisor Settings) setting is enabled, switching private calls off does not affect that status. To allow private calls to be used to fully control the user status, **Cannot be Intruded** (User | Telephony | Supervisor Settings) should be disabled for the user.

If enabled during a call, any current recording, intrusion or monitoring is ended.

**Action:** Advanced | Call | Private Call.

**Action Data:** None.

**Default Label:** PrivC or Private Call.

**Toggles:** Yes.

**Status Indication:** Yes.

Status	2400, 5400 Series	4600, 5600 Series	1400, 1600, 4400, 6400, 9500 Series	9600 Series	9608, 9611, J139, J159, J169, J179	9621, 9641	T-Series, M-Series
- On.	<Label> ◀	<Label>	Green on	Red on	Green on	■ Green	▲ On
- Off.	<Label>	<Label>	Off	Off	Off	■ Grey	Off

**User Admin:** No.

Phone Support Note that support for particular phone models is also dependant on the system software level.

Analog: ✗	20 Series: ✗	4100 Series: ✗	6400 Series: ✗	D100: ✓
1100 Series: ✓	2400 Series: ✓	4400 Series: ✓	7400 Series: ✗	M-Series: ✓
1200 Series: ✓	3600 Series: ✗	4600 Series: ✓ [1]	9040: ✓	T-Series: ✓
1400 Series: ✓	3700 Series: ✗	5400 Series: ✓	9500 Series: ✓	T3/T3 IP Series: ✗
1600 Series: ✓	3810: ✓	5600 Series: ✓ [1]	9600 Series: ✓	

1. Not 1603, 4601, 4602, 5601 and 5602.

## Relay Off

Opens the specified switch in the system's external output port (**EXT O/P**).

This feature is not supported on Linux based systems. For Server Edition, this option is only supported on Expansion System (V2) units.

**Action:** Advanced | Relay | Relay Off.

**Action Data:** Switch number (1 or 2).

**Default Label:** Rely-.

**Toggles:** No.

**Status Indication:** No.

**User Admin:** No.

**Phone Support** Note that support for particular phone models is also dependant on the system software level.

Analog: ✗	20 Series: ✓	4100 Series: ✗	6400 Series: ✓	D100: ✗
1100 Series: ✗	2400 Series: ✓ [1]	4400 Series: ✓	7400 Series: ✗	M-Series: ✗
1200 Series: ✗	3600 Series: ✗	4600 Series: ✓ [1]	9040: ✓	T-Series: ✗
1400 Series: ✓ [1]	3700 Series: ✗	5400 Series: ✓	9500 Series: ✗	T3/T3 IP Series: ✗
1600 Series: ✓ [1]	3810: ✓	5600 Series: ✓ [1]	9600 Series: ✗	

1. Not 1403, 1603, 2402, 4601, 4602, 5601 and 5602 except where 4602 is supported on Release 2.1 and 3.0DT software.

## Relay On

Closes the specified switch in the system's external output port (**EXT O/P**).

This feature is not supported on Linux based systems. For Server Edition, this option is only supported on Expansion System (V2) units.

**Action:** Advanced | Relay | Relay On.

**Action Data:** Switch number (1 or 2).

**Default Label:** Rely+ or Relay On.

**Toggles:** Yes.

**Status Indication:** No.

**User Admin:** No.

**Phone Support** Note that support for particular phone models is also dependant on the system software level.

Analog: ✗	20 Series: ✓	4100 Series: ✗	6400 Series: ✓	D100: ✓
-----------	--------------	----------------	----------------	---------

*Table continues...*



1100 Series: ✓	2400 Series: ✓ [1]	4400 Series: ✓	7400 Series: ✗	M-Series: ✓
1200 Series: ✓	3600 Series: ✗	4600 Series: ✓ [1]	9040: ✓	T-Series: ✓
1400 Series: ✓ [1]	3700 Series: ✗	5400 Series: ✓	9500 Series: ✓	T3/T3 IP Series: ✗
1600 Series: ✓ [1]	3810: ✓	5600 Series: ✓ [1]	9600 Series: ✓	

1. Not 1403, 1603, 4601, 4602, 5601 and 5602 except where 4602 is supported on Release 2.1 and 3.0DT software.

## Relay Pulse

Closes the specified switch in the system's external output port (**EXT O/P**) for 5 seconds and then opens the switch.

This feature is not supported on Linux based systems. For Server Edition, this option is only supported on Expansion System (V2) units.

**Action:** Advanced | Relay | Relay Pulse.

**Action Data:** Switch number (1 or 2).

**Default Label:** Relay or Relay Pulse.

**Toggles:** No.

**Status Indication:** No.

**User Admin:** No.

**Phone Support** Note that support for particular phone models is also dependant on the system software level.

Analog: ✗	20 Series: ✓	4100 Series: ✗	6400 Series: ✓	D100: ✓
1100 Series: ✓	2400 Series: ✓ [1]	4400 Series: ✓	7400 Series: ✗	M-Series: ✓
1200 Series: ✓	3600 Series: ✗	4600 Series: ✓ [1]	9040: ✓	T-Series: ✓
1400 Series: ✓ [1]	3700 Series: ✗	5400 Series: ✓	9500 Series: ✓	T3/T3 IP Series: ✗ [12]
1600 Series: ✓ [1]	3810: ✓	5600 Series: ✓ [1]	9600 Series: ✓	

1. Not 1403, 1603, 4601, 4602, 5601 and 5602 except where 4602 is supported on Release 2.1 and 3.0DT software.
2. Limited support on some specific T3 phone models as detailed below.

### T3 Phones:

- **Classic/Comfort icon:** Displays **S1** or **S2** dependant on switch number.
- **DSS Link LED:** None.

## Resume Call

Resume a call previously suspended to the specified ISDN exchange slot. The suspended call may be resumed from another phone/ISDN Control Unit on the same line.

**Action:** Advanced | Call | Resume Call.

**Action Data:** ISDN Exchange suspend slot number.

**Default Label:** Resum.

**Toggles:** No.

**Status Indication:** No.

**User Admin:** No.

**Phone Support** Note that support for particular phone models is also dependant on the system software level.

<b>Analog:</b> ✗	<b>20 Series:</b> ✓	<b>4100 Series:</b> ✗	<b>6400 Series:</b> ✓	<b>D100:</b> ✗
<b>1100 Series:</b> ✗	<b>2400 Series:</b> ✓ [1]	<b>4400 Series:</b> ✓	<b>7400 Series:</b> ✗	<b>M-Series:</b> ✗
<b>1200 Series:</b> ✗	<b>3600 Series:</b> ✗	<b>4600 Series:</b> ✓ [1]	<b>9040:</b> ✓	<b>T-Series:</b> ✗
<b>1400 Series:</b> ✓ [1]	<b>3700 Series:</b> ✗	<b>5400 Series:</b> ✓	<b>9500 Series:</b> ✗	<b>T3/T3 IP Series:</b> ✗
<b>1600 Series:</b> ✓ [1]	<b>3810:</b> ✓	<b>5600 Series:</b> ✓ [1]	<b>9600 Series:</b> ✗	

1. Not 1403, 1603, 2402, 4601, 4602, 5601 and 5602 except where 4602 is supported on Release 2.1 and 3.0DT software.

## Request Coaching Intrusion

This feature allows a user to request that another user intrude on a call and talk to them without being heard by the other call parties to which they can still talk.

The ability to intrude and be intruded is controlled by two configuration settings, the Can Intrude (User | Telephony | Supervisor Settings) setting of the user intruding and the Cannot Be Intruded (User | Telephony | Supervisor Settings) setting of target being intruded on. The setting of any other internal party is ignored. By default, no users can intrude and all users are set to cannot be intruded.

### **Warning:**

The use of features to listen to a call without the other call parties being aware of that monitoring may be subject to local laws and regulations. Before enabling the feature you must ensure that you have complied with all applicable local laws and regulations. Failure to do so may result in severe penalties.

The system support a range of other call intrusion methods in addition to this feature.

**Action:** Advanced | Call | Request Coaching Intrusion.

**Action Data:** None.

**Default Label:** Request Coach or Request Coaching Intrusion.

**Toggles:** Yes.

**Status Indication:** No.

**User Admin:** No.

**Phone Support** Note that support for particular phone models is also dependant on the system software level.

Analog: ✗	20 Series: ✗	4100 Series: ✗	6400 Series: ✗	D100: ✗
1100 Series: ✗	2400 Series: ✗	4400 Series: ✗	7400 Series: ✗	M-Series: ✗
1200 Series: ✗	3600 Series: ✗	4600 Series: ✗	9040: ✗	T-Series: ✗
1400 Series: ✓ [1]	3700 Series: ✗	5400 Series: ✗	9500 Series: ✓	T3/T3 IP Series: ✗
1600 Series: ✓ [1]	3810: ✗	5600 Series: ✗	9600 Series: ✓	

1. Not 1403, 1603.

The Request Coaching Intrusion feature exhibits the following behavior:

- A coaching request can be sent to a user or a group.
- While the request is pending, the user can cancel the request by pressing the Request Coach button again.
- Once a coaching session is established, the user that initiated the request can include the coach in the call, transfer the call to the coach, or drop the coach from the call.
- Once a coaching session is established, the coach can join the call or steal the call. The coach cannot transfer or conference the call.
- Once the primary call ends, the coaching call continues.

---

## Retrieve Call

Retrieves a call previously held to a specific ISDN exchange slot. Only available when supported by the ISDN exchange.

**Action:** Advanced | Call | Retrieve Call.

**Action Data:** Exchange hold slot number.

**Default Label:** Retriv.

**Toggles:** No.

**Status Indication:** No.

**User Admin:** No.

**Phone Support** Note that support for particular phone models is also dependant on the system software level.

<b>Analog:</b> No	<b>20 Series:</b> Yes	<b>4100 Series:</b> No	<b>6400 Series:</b> Yes	<b>D100:</b> No
<b>1100 Series:</b> Yes	<b>2400 Series:</b> Yes [1]	<b>4400 Series:</b> Yes	<b>7400 Series:</b> No	<b>M-Series:</b> No
<b>1200 Series:</b> Yes	<b>3600 Series:</b> No	<b>4600 Series:</b> Yes [1]	<b>9040:</b> ✓	<b>T-Series:</b> No
<b>1400 Series:</b> Yes [1]	<b>3700 Series:</b> No	<b>5400 Series:</b> Yes	<b>9500 Series:</b> No	<b>T3/T3 IP Series:</b> No
<b>1600 Series:</b> Yes [1]	<b>3810:</b> Yes	<b>5600 Series:</b> Yes [1]	<b>9600 Series:</b> No	

1. Not 1403, 1603, 2402, 4601, 4602, 5601 and 5602 except where 4602 is supported on Release 2.1 and 3.0DT software.

## Ring Back When Free

Sets a ringback on the extension being called. When the target extension ends its current call, the ringback users is rung (for their set No Answer Time) and if they answer, a new call is made to the target extension.

Ringback can be cleared using the Cancel Ring Back When Free function.

- **Action:** Advanced | Miscellaneous | Ring Back When Free.
- **Action Data:** None.
- **Default Label:** AutCB or Auto Callback.
- **Toggles:** No.
- **Status Indication:** Yes.

Status	2400, 5400 Series	4600, 5600 Series	1400, 1600, 4400, 6400, 9500 Series	9600 Series	9608, 9611, J139, J159, J169, J179, J189	9621, 9641	T-Series, M-Series
- On.	<Label> ◀	<Label>	Green on	Red on	Green on	■ Green	▲ On
- Off.	<Label>	<Label>	Off	Off	Off	■ Grey	Off

- **User Admin:** No.
- **Phone Support** Note that support for particular phone models is also dependant on the system software level.

Analog: ✗	20 Series: ✓	4100 Series: ✗	6400 Series: ✓	D100: ✗
1100 Series: ✗	2400 Series: ✓ [1]	4400 Series: ✓	7400 Series: ✗	M-Series: ✓
1200 Series: ✗	3600 Series: ✗	4600 Series: ✓ [1]	9040: ✓	T-Series: ✓
1400 Series: ✓ [1]	3700 Series: ✗	5400 Series: ✓	9500 Series: ✓	T3/T3 IP Series: ✗ [2]
1600 Series: ✓ [1]	3810: ✓	5600 Series: ✓ [1]	9600 Series: ✓	Vantage Connect Expansion: ✓

1. Not 1403, 1603, 4601, 4602, 5601 and 5602 except where 4602 is supported on Release 2.1 and 3.0DT software.
2. Limited support on some specific T3 phone models as detailed below.

M-Series/T-Series: The button is equivalent to **Feature 2**.

## Ringer Off

Switches the phone's call alerting ring on/off.

**Action:** Emulation | Ringer Off.

**Action Data:** None.

**Default Label:** RngOf or Ringer Off.

**Toggles:** Yes.

**Status Indication:** Yes Required.

Status	2400, 5400 Series	4600, 5600 Series	1400, 1600, 4400, 6400, 9500 Series	9600 Series	9608, 9611, J139, J159, J169, J179, J189	9621, 9641	T-Series, M-Series
- On.	<Label> ◀	<Label>	Green on	Red on	Green on	■ Green	▲ On
- Off.	<Label>	<Label>	Off	Off	Off	■ Grey	Off

**User Admin:** Yes.

**Phone Support** Note that support for particular phone models is also dependant on the system software level.

Analog: ✗	20 Series: ✓	4100 Series: ✗	6400 Series: ✓	D100: ✗
1100 Series: ✗	2400 Series: ✓ [1]	4400 Series: ✓	7400 Series: ✗	M-Series: ✓
1200 Series: ✗	3600 Series: ✗	4600 Series: ✓ [1]	9040: ✓	T-Series: ✓

*Table continues...*

<b>1400 Series:</b> ✓ [1]	<b>3700 Series:</b> ✗	<b>5400 Series:</b> ✓	<b>9500 Series:</b> ✓	<b>T3/T3 IP Series:</b> ✗
<b>1600 Series:</b> ✓ [1]	<b>3810:</b> ✓	<b>5600 Series:</b> ✓ [1]	<b>9600 Series:</b> ✓	

1. Not 1403, 1603, 4601, 4602, 5601 and 5602 except where 4602 is supported on Release 2.1 and 3.0DT software.

---

## Self-Administer









Allows a user to program features against other programmable buttons themselves.

Appearance can no longer be used to create call appearance buttons. Similarly, existing call appearance button cannot be overwritten using any of the other Admin button functions.

User's with a log in code will be prompted to enter that code when they use this button action.

T3 phone users can access a similar set of functions for button programming, see T3 Phone Self-Administration.

On 4412D+, 4424D+, 4612IP, 4624IP, 6408D, 6416D, 6424D phones:

- **Admin** can be permanently accessed via **Menu** , , , **Admin**. See Using a Menu Key.
- **Admin1** can be permanently accessed via **Menu** , **Menu** , , **ProgA**, , , **DSS**.

**Action:** Emulation | Self-Administer.

**Action Data:** See below.

Value	T-Series and M-Series phones	Other Phones
<b>None</b>	The <b>Feature *3</b> process is started with an alternate set of possible functions.	<p>If no value is set, the button allows user programming of the following emulation actions:</p> <ul style="list-style-type: none"> <li>• <b>Abbreviated Dial</b></li> <li>• <b>Abbreviated Dial Program</b></li> <li>• <b>Account Code Entry</b></li> <li>• <b>AD Suppress</b></li> <li>• <b>Automatic Callback</b></li> <li>• <b>Break Out</b></li> <li>• <b>Call Forwarding All</b></li> <li>• <b>Call Park</b></li> <li>• <b>Call Park and Page</b></li> <li>• <b>Call Park To Other Extension</b></li> <li>• <b>Call Pickup</b></li> <li>• <b>Call Pickup Any</b></li> <li>• <b>Conference Meet Me</b></li> <li>• <b>Dial Paging</b></li> <li>• <b>Directed Call Pickup</b></li> <li>• <b>Directory</b></li> <li>• <b>Drop</b></li> <li>• <b>Group Paging</b></li> <li>• <b>Headset Toggle</b></li> <li>• <b>Hook Flash</b></li> <li>• <b>Internal Auto-Answer</b></li> <li>• <b>Ringer Off</b></li> <li>• <b>Self-Administer</b></li> <li>• <b>Send All Calls</b></li> <li>• <b>Set Absent Text</b></li> <li>• <b>Set Hunt Group Night Service</b></li> <li>• <b>Time of Day</b></li> <li>• <b>Timer</b></li> <li>• <b>Twinning</b></li> </ul>

*Table continues...*

Value	T-Series and M-Series phones	Other Phones
1	The <b>Feature *1</b> process is started for assigning <b>Abbreviated Dial</b> button.	If <b>1</b> is entered as the telephone number, allows user programming of the following system functions. <ul style="list-style-type: none"> <li>• <b>Abbreviated Dial</b></li> <li>• <b>Group</b></li> <li>• <b>CPark</b></li> <li>• <b>User</b></li> <li>• <b>Flash Hook</b></li> </ul>
2	The <b>Feature *6</b> process is started for setting the ring type.	If <b>2</b> is entered, the button can be used for viewing details of the control unit type and its software version. This option is available. If the user has a log in code set, they will be prompted to enter that code. System phone users (see <a href="#">System Phone Features</a> on page 727) can also use the button to manually set the system's date and time.
3	The option <b>3</b> is used with M-Series and T-Series sets to enable display contrast control.	Not used.

**Default Label:** Admin or Self Administer.

**Toggles:** No.

**Status Indication:** No.

**User Admin:** Yes.

Phone Support Note that support for particular phone models is also dependant on the system software level.

Analog: ✗	3600 Series: ✗	4600 Series: ✓ [1]	9040: ✓	T3/T3 IP Series: ✓ [2]
1400 Series: ✓	3700 Series: ✗	5400 Series: ✓ [1]	9500 Series: ✓	
1600 Series: ✓	3810: ✓	5600 Series: ✓ [1]	9600 Series: ✓	
20 Series: ✓	4100 Series: ✗	6400 Series: ✓	M-Series: ✓	
2400 Series: ✓	4400 Series: ✓	7400 Series: ✗	T-Series: ✓	

1. Not 1403, 1603, 2402, 5402, 4601, 4602, 5601 and 5602.

2. See T3 Phone Self-Administration.



## Send All Calls

Sets the user's extension into 'Do Not Disturb' mode. Callers, other than those on the user's do not disturb exception list, receive busy or are diverted to the user's voicemail mailbox. Note that with a call already connected and other calls already alerting, enabling Do Not Disturb will not affect those calls already existing. For full details of see Do Not Disturb.

When on, most phones display an **N** on the display. This function and the Do Not Disturb On function work in parallel, ie. setting one sets the other.

**Action:** Emulation | Send All Call.

**Action Data:** None.

**Default Label:** SAC or Send All Calls.

**Toggles:** Yes.

**Status Indication:** Yes.

Status	2400, 5400 Series	4600, 5600 Series	1400, 1600, 4400, 6400, 9500 Series	9600 Series	9608, 9611, J139, J159, J169, J179, J189	9621, 9641	T-Series, M-Series
- On.	<Label> ◀	<Label>	Green on	Red on	Green on	■ Green	▲ On
- Off.	<Label>	<Label>	Off	Off	Off	■ Grey	Off

**User Admin:** Yes.

**Phone Support** Note that support for particular phone models is also dependant on the system software level.

Analog: ✗	20 Series: ✓	4100 Series: ✗	6400 Series: ✓	D100: ✗
1100 Series: ✗	2400 Series: ✓ [1]	4400 Series: ✓	7400 Series: ✗	M-Series: ✓
1200 Series: ✗	3600 Series: ✗	4600 Series: ✓ [1]	9040: ✓	T-Series: ✓
1400 Series: ✓ [1]	3700 Series: ✗	5400 Series: ✓	9500 Series: ✓	T3/T3 IP Series: ✗ [2]
1600 Series: ✓ [1]	3810: ✓	5600 Series: ✓ [1]	9600 Series: ✓	

1. Not 1403, 1603, 4601, 4602, 5601 and 5602 except where 4602 is supported on Release 2.1 and 3.0DT software.
2. Limited support on some specific T3 phone models as detailed below.

### T3 Phones:

- **Classic/Comfort icon:** Displays **[#]**.
- **DSS Link LED:** On when active.

## Set Absent Text

This feature can be used to select the user's current absence text. This text is then displayed to internal callers who have suitable display phones or applications. It doesn't changes the users status. The absence text message is limited to 128 characters. Note however that the amount displayed will depend on the caller's device or application.

The text is displayed to callers even if the user has forwarded their calls or is using follow me. Absence text is supported across a multi-site network.

**\* Note:**

The user still has to select **Set** or **Clear** on their phone to display or hide the text.

**Action:** Advanced | Set | Set Absent Text.

**Action Data:** Optional.

**\* Note:**

On certain phones (1400, 1600, 9500 and 9600), if the button is set without any Action Data, the user is prompted to select their absence text and switch it on/off through a menu shown on the phone display.

The telephone number should take the format "**y,n,text**" where:

- **y** = 0 or 1 to turn this feature off or on repectively.
- **n** = the number of the absent statement to use:

0 = None.	4 = Meeting until.	8 = With cust. til.
1 = On vacation until.	5 = Please call.	9 = Back soon.
2 = Will be back.	6 = Don't disturb until.	10 = Back tomorrow.
3 = At lunch until.	7 = With visitors until.	11 = Custom.

**text** = any text to follow the absent statement..

**Default Label:** Absnt or Absence Text.

**Toggles:** No.

**Status Indication:** No.

**User Admin:** No.

**Phone Support** Note that support for particular phone models is also dependant on the system software level.

<b>Analog:</b> No	<b>20 Series:</b> Yes	<b>4100 Series:</b> No	<b>6400 Series:</b> ✓	<b>D100:</b> No
<b>1100 Series:</b> No	<b>2400 Series:</b> Yes [1]	<b>4400 Series:</b> Yes	<b>7400 Series:</b> No	<b>M-Series:</b> Yes

*Table continues...*

<b>1200 Series:</b> No	<b>3600 Series:</b> No	<b>5400 Series:</b> Yes [1]	<b>9040:</b> Yes	<b>T-Series:</b> Yes
<b>1400 Series:</b> Yes [1]	<b>3700 Series:</b> No	<b>4600 Series:</b> Yes [1]	<b>9500 Series:</b> Yes	<b>T3/T3 IP Series:</b> No
<b>1600 Series:</b> Yes [1]	<b>3810:</b> Yes	<b>5600 Series:</b> Yes [1]	<b>9600 Series:</b> Yes	

1. Not 1403, 1603, 2402, 4601, 4602, 5402, 5601 and 5602.

## Set Account Code

Dials an account code and then returns dial tone for the user to dial a number. Can also be used to enter an account code after a call has been connected.

**Action:** Advanced | Set | Set Account Code..

**Action Data:** Account code or blank. If blank, the user is prompted to dial an account code after pressing the button. This option is not supported on XX02 phone modules.

**Default Label:** Acct or Account Code.

**Toggles:** No.

**Status Indication:** No.

**User Admin:** No.

**Phone Support** Note that support for particular phone models is also dependant on the system software level.

<b>Analog:</b> ✗	<b>20 Series:</b> ✓	<b>4100 Series:</b> ✗	<b>6400 Series:</b> ✓	<b>D100:</b> ✗
<b>1100 Series:</b> ✗	<b>2400 Series:</b> ✓ [1]	<b>4400 Series:</b> ✓	<b>7400 Series:</b> ✗	<b>M-Series:</b> ✓
<b>1200 Series:</b> ✗	<b>3600 Series:</b> ✗	<b>4600 Series:</b> ✓ [1]	<b>9040:</b> ✓	<b>T-Series:</b> ✓
<b>1400 Series:</b> ✓ [1]	<b>3700 Series:</b> ✗	<b>5400 Series:</b> ✓	<b>9500 Series:</b> ✓	<b>T3/T3 IP Series:</b> ✗ [2]
<b>1600 Series:</b> ✓ [1]	<b>3810:</b> ✓	<b>5600 Series:</b> ✓ [1]	<b>9600 Series:</b> ✓	

1. Not 1403, 1603, 4601, 4602, 5601 and 5602 except where 4602 is supported on Release 2.1 and 3.0DT software.
2. Limited support on some specific T3 phone models as detailed below.

### T3 Phones:

- **Classic/Comfort icon:** Displays **1234**.
- **DSS Link LED:** None.

## Set Hunt Group Night Service

Puts the specified hunt group into Night Service mode. Calls to a group set to night service, receive busy or are diverted to voicemail if available or are diverted to the group's night service fallback group if set.

Setting and clearing hunt group night service can be done using either manual controls or using a system time profile. The use of both methods to control the night service status of a particular hunt group is not supported.

This function is not supported between systems in a multi-site network. It can only be used by a user currently logged onto the same system as hosting the hunt group.

**Action:** Advanced | Set | Set Hunt Group Night Service.

**Action Data:** Hunt group extension number.

Release 4.0+: If left blank, the button will affect all hunt groups of which the user is a member.

The **Set Hunt Group Night Service** and **Clear Hunt Group Night Service** short code and button features can be used to switch an SSL VPN service off or on respectively. The service is indicated by setting the service name as the telephone number or action data. Do not use quotation marks.

**Default Label:** HGNS+ or HG Night Service.

**Toggles:** Yes.

**Status Indication:** Yes Required. If the button is blank (no specific hunt group) it will indicate on if any one of the hunt groups of which the user is a member is set to night service. If the button is set for multiple hunt groups it will indicate on if any one of those groups is set to night service.

Status	2400, 5400 Series	4600, 5600 Series	1400, 1600, 4400, 6400, 9500 Series	9600 Series	9608, 9611, J139, J159, J169, J179, J189	9621, 9641	T-Series, M-Series
- On.	<Label> ◀	<Label>	Green on	Red on	Green on	■ Green	▲ On
- Off.	<Label>	<Label>	Off	Off	Off	■ Grey	Off

**User Admin:** No.

**Phone Support** Note that support for particular phone models is also dependant on the system software level.

Analog: ✗	20 Series: ✓	4100 Series: ✗	6400 Series: ✓	D100: ✗
1100 Series: ✗	2400 Series: ✓ [1]	4400 Series: ✓	7400 Series: ✗	M-Series: ✓
1200 Series: ✗	3600 Series: ✗	4600 Series: ✓ [1]	9040: ✓	T-Series: ✓
1400 Series: ✓ [1]	3700 Series: ✗	5400 Series: ✓	9500 Series: ✓	T3/T3 IP Series: ✗ [2]

*Table continues...*

1600 Series: ✓ [1]	3810: ✓	5600 Series: ✓ [1]	9600 Series: ✓	
--------------------	---------	--------------------	----------------	--

1. Not 1403, 1603, 4601, 4602, 5601 and 5602 except where 4602 is supported on Release 2.1 and 3.0DT software.
2. Limited support on some specific T3 phone models as detailed below.

**T3 Phones:** Supported on Avaya T3 Classic, T3 Comfort phones and DSS Link units only.

- **T3 Classic/T3 Comfort icon:** Displays  followed by the group number. The background uses the same settings as the LED below.
- **DSS Link LED:** On when all related groups are in night service. Slow flash if related hunt groups are in mixed states.

## Set Hunt Group Out Of Service

Puts the specified hunt group into Out of Service mode. Calls to a group set to out of service receive busy or are diverted to voicemail if available or are diverted to the group's out of service fallback group if set.

This function can be used to override hunt groups already set to night service mode by an associated time profile.

**Action:** Advanced | Set | Set Hunt Group Out of Service.



**Action Data:** Hunt group extension number.

If left blank, the button will affect all hunt groups of which the user is a member.

**Default Label:** HGOS+ or HG Out of Service.

**Toggles:** Yes.

**Status Indication:** Yes Required. If the button is blank (no specific hunt group) it will indicate on if any one of the hunt groups of which the user is a member is set out of service. If the button is set for multiple hunt groups it will indicate on if any one of those groups is set out of service.

Status	2400, 5400 Series	4600, 5600 Series	1400, 1600, 4400, 6400, 9500 Series	9600 Series	9608, 9611, J139, J159, J169, J179, J189	9621, 9641	T-Series, M-Series
- On.	<Label> ◀	<Label>	Green on	Red on	Green on	 Green	 On
- Off.	<Label>	<Label>	Off	Off	Off	 Grey	Off

**User Admin:** No.

**Phone Support** Note that support for particular phone models is also dependant on the system software level.

Analog: ✗	20 Series: ✔	4100 Series: ✗	6400 Series: ✔	D100: ✗
1100 Series: ✗	2400 Series: ✔ [1]	4400 Series: ✔	7400 Series: ✗	M-Series: ✔
1200 Series: ✗	3600 Series: ✗	4600 Series: ✔ [1]	9040: ✔	T-Series: ✔
1400 Series: ✔ [1]	3700 Series: ✗	5400 Series: ✔	9500 Series: ✔	T3/T3 IP Series: ✗ [2]
1600 Series: ✔ [1]	3810: ✔	5600 Series: ✔ [1]	9600 Series: ✔	

1. Not 1403, 1603, 4601, 4602, 5601 and 5602 except where 4602 is supported on Release 2.1 and 3.0DT software.
2. Limited support on some specific T3 phone models as detailed below.

**T3 Phones:**

- **Classic/Comfort icon:** Displays – followed by the group number. The background uses the same settings as the LED below.
- **DSS Link LED:** On when set. On when all related groups are out of service. Slow flash if related hunt groups are in mixed states.

## Set Inside Call Seq

This feature allows the user to select the ringing used on their analog extension for internal calls. The number entered corresponds to the ring pattern required. This is 0 for Default Ring, 1 for RingNormal, 2 for RingType1, etc. For more information on selectable ringing patterns, see Ring Tones. Use of this short code function is applicable to analog phone users only. The distinctive ringing pattern used for other phones is set by the phone type.

## Set Night Service Destination

This button allows the user to change the Night Service target of a hunt group. The button user does not have to be a member of the hunt group. In a multi-site network this function can be used for hunt groups on remote systems.

Changing the destination does not affect calls already ringing at the hunt groups previous night service destination.

**Action:** Advanced | Set | Set Night Service Group.

**Action Data:** Hunt group extension number. This is the group for which the night service destination is being set.

**Default Label:** SetNSG or HG NS Group.

**Toggles:** No.

**Status Indication:** No.

**User Admin:** No.

**Phone Support** Note that support for particular phone models is also dependant on the system software level.

<b>Analog:</b> ✗	<b>20 Series:</b> ✓	<b>4100 Series:</b> ✗	<b>6400 Series:</b> ✓	<b>D100:</b> ✗
<b>1100 Series:</b> ✗	<b>2400 Series:</b> ✓ [1]	<b>4400 Series:</b> ✓	<b>7400 Series:</b> ✗	<b>M-Series:</b> ✓
<b>1200 Series:</b> ✗	<b>3600 Series:</b> ✗	<b>4600 Series:</b> ✓ [1]	<b>9040:</b> ✓	<b>T-Series:</b> ✓
<b>1400 Series:</b> ✓ [1]	<b>3700 Series:</b> ✗	<b>5400 Series:</b> ✓	<b>9500 Series:</b> ✓	<b>T3/T3 IP Series:</b> ✗ [2]
<b>1600 Series:</b> ✓ [1]	<b>3810:</b> ✓	<b>5600 Series:</b> ✓ [1]	<b>9600 Series:</b> ✓	

1. Not 1403, 1603, 4601, 4602, 5601 and 5602 except where 4602 is supported on Release 2.1 and 3.0DT software.
2. Limited support on some specific T3 phone models as detailed below.

On T3 phones this option is accessible through the phone's menus.

## Set No Answer Time

Allows the user to change their no answer time setting. This is the time calls ring before going to voicemail or following the user's divert on no answer setting if set on.

In situations where call coverage is also being used, the user's no answer time must be greater than their individual coverage time for coverage to occur.

**Action:** Advanced | Set | Set No Answer Time.

**Action Data:** Time in seconds.

**Default Label:** NATim or No Answer Time.

**Toggles:** No.

**Status Indication:** No.

**User Admin:** No.

**Phone Support** Note that support for particular phone models is also dependant on the system software level.

<b>Analog:</b> ✗	<b>20 Series:</b> ✓	<b>4100 Series:</b> ✗	<b>6400 Series:</b> ✓	<b>D100:</b> ✗
<b>1100 Series:</b> ✗	<b>2400 Series:</b> ✓ [1]	<b>4400 Series:</b> ✓	<b>7400 Series:</b> ✗	<b>M-Series:</b> ✓
<b>1200 Series:</b> ✗	<b>3600 Series:</b> ✗	<b>4600 Series:</b> ✓ [1]	<b>9040:</b> ✓	<b>T-Series:</b> ✓
<b>1400 Series:</b> ✓ [1]	<b>3700 Series:</b> ✗	<b>5400 Series:</b> ✓	<b>9500 Series:</b> ✓	<b>T3/T3 IP Series:</b> ✗

*Table continues...*

1600 Series: ✓ [1]	3810: ✓	5600 Series: ✓ [1]	9600 Series: ✓	
--------------------	---------	--------------------	----------------	--

1. Not 1403, 1603, 4601, 4602, 5601 and 5602 except where 4602 is supported on Release 2.1 and 3.0DT software.

## Set Out of Service Destination

This button allows the user to change the Out of Service target of a hunt group. The button user does not have to be a member of the hunt group. In a multi-site network this function can be used for hunt groups on remote systems.

Changing the destination does not affect calls already ringing at the hunt groups previous Out of Service destination.

**Action:** Advanced | Set | Set Out of Service Group.

**Action Data:** Hunt group extension number. This is the group for which the night service destination is being set.

**Default Label:** SetOOSG or HG OS Group.

**Toggles:** No.

**Status Indication:** No.

**User Admin:** No.

**Phone Support** Note that support for particular phone models is also dependant on the system software level.

Analog: ✗	20 Series: ✓	4100 Series: ✗	6400 Series: ✓	D100: ✗
1100 Series: ✗	2400 Series: ✓ [1]	4400 Series: ✓	7400 Series: ✗	M-Series: ✓
1200 Series: ✗	3600 Series: ✗	4600 Series: ✓ [1]	9040: ✓	T-Series: ✓
1400 Series: ✓ [1]	3700 Series: ✗	5400 Series: ✓	9500 Series: ✓	T3/T3 IP Series: ✗ [2]
1600 Series: ✓ [1]	3810: ✓	5600 Series: ✓ [1]	9600 Series: ✓	

1. Not 1403, 1603, 4601, 4602, 5601 and 5602 except where 4602 is supported on Release 2.1 and 3.0DT software.
2. Limited support on some specific T3 phone models as detailed below.  
On T3 phones this option is accessible through the phone's menus.



---

## Set Outside Call Seq

This feature allows the user to select the ringing used on their analog extension for external calls.

The number entered corresponds to the ring pattern required. This is 0 for Default Ring, 1 for RingNormal, 2 for RingType1, etc. For more information on selectable ringing patterns, see Ring Tones. Use of this short code function is applicable to analog phone users only. The distinctive ringing pattern used for other phones is set by the phone type.

---

## Set Ringback Seq

This feature allows the user to select the ringing used on their analog extension for ringback calls.

The number entered corresponds to the ring pattern required. This is 0 for Default Ring, 1 for RingNormal, 2 for RingType1, etc. For more information on selectable ringing patterns, see Ring Tones. Use of this short code function is applicable to analog phone users only. The distinctive ringing pattern used for other phones is set by the phone type.

---

## Set Wrap Up Time

Allows users to change their Wrap-up Time (User | Telephony | Call Settings) setting.

Other phones or applications monitoring the user's status will indicate the user as still being busy (on a call).

Hunt group calls will not be presented to the user.

If the user is using a single line set, direct calls also receive busy treatment. If the user is using a mutli-line set (multiple call appearances), direct calls to them will ring as normal.

It is recommended that this option is not set to less than the default of 2 seconds. 0 is used to allow immediate ringing.

For users set as an CCR Agent, the After Call Work Time (User | Telephony | Supervisor Settings) setting should be used.

 **Note:**

CCR is not supported in IP Office release 9.1 and later.

**Action:** Advanced | Set | Set Wrap Up Time.

**Action Data:** Time in seconds. Range 0 to 99999 seconds.

**Default Label:** WUTim or Wrap-up Time.

**Toggles:** No.

**Status Indication:** No.

**User Admin:** No.

**Phone Support** Note that support for particular phone models is also dependant on the system software level.

<b>Analog:</b> ✗	<b>20 Series:</b> ✓	<b>4100 Series:</b> ✗	<b>6400 Series:</b> ✓	<b>D100:</b> ✗
<b>1100 Series:</b> ✗	<b>2400 Series:</b> ✓ [1]	<b>4400 Series:</b> ✓	<b>7400 Series:</b> ✗	<b>M-Series:</b> ✓
<b>1200 Series:</b> ✗	<b>3600 Series:</b> ✗	<b>4600 Series:</b> ✓ [1]	<b>9040:</b> ✓	<b>T-Series:</b> ✓
<b>1400 Series:</b> ✓ [1]	<b>3700 Series:</b> ✗	<b>5400 Series:</b> ✓	<b>9500 Series:</b> ✓	<b>T3/T3 IP Series:</b> ✗
<b>1600 Series:</b> ✓ [1]	<b>3810:</b> ✓	<b>5600 Series:</b> ✓ [1]	<b>9600 Series:</b> ✓	

1. Not 1403, 1603, 4601, 4602, 5601 and 5602 except where 4602 is supported on Release 2.1 and 3.0DT software.

## Speed Dial

When pressed, the button invokes the same process as dialing **Feature 0**.

If **Feature 0** is followed by a 3-digit index number in the range 000 to 999, the system directory entry with the matching index number is dialed.

If **Feature 0** is followed by \* and a 2-digit index number in the range 00 to 99, the personal directory entry with the matching index number is dialed. Note: Release 10.0 allows users to have up to 250 personal directory entries. However, only 100 of those can be assigned index numbers.

**Action:** Advanced | Dial | Speed Dial.

**Action Data:** None.

**Default Label:** SpdDial.

**Toggles:** No.

**Status Indication:** No.

**User Admin:** No.

### Phone Support

**Phone Support** Note that support for particular phone models is also dependant on the system software level.

<b>Analog:</b> No	<b>20 Series</b>	<b>4100 Series:</b> No	<b>6400 Series:</b> No	<b>D100:</b> No
<b>1100 Series:</b> Yes	<b>2400 Series:</b> No	<b>4400 Series:</b> No	<b>7400 Series:</b> No	<b>M-Series:</b> Yes
<b>1200 Series:</b> Yes	<b>3600 Series:</b> No	<b>4600 Series:</b> No	<b>9040:</b> No	<b>T-Series:</b> Yes

*Table continues...*

1400 Series: No	3700 Series: No	5400 Series: No	9500 Series: No	T3/T3 IP Series: No
1600 Series: No	3810: No	5600 Series: No	9600 Series: No	

---

## Stamp Log

The stamp log function is used to insert a line into any System Monitor trace that is running. The line in the trace indicates the date, time, user name and extension plus additional information. The line is prefixed with **LSTMP: Log Stamped** and a log stamp number. When invoked from a Avaya phone with a display, **Log Stamped#** is also briefly displayed on the phone. This allows users to indicate when they have experienced a particular problem that the system maintainer want them to report and allows the maintainer to more easily locate the relevant section in the monitor trace.

The log stamp number is set to 000 when the system is restarted. The number is then incremented after each time the function is used in a cycle between 000 and 999. Alternately if required, a specific stamp number can be assigned to the button or short code being used for the feature.

**Action:** Advanced | Miscellaneous | Stamp Log.

**Action Data:** Optional. Blank or any 3 digit number.

**Default Label:** Stamp Log.

**Toggles:** No.

**Status Indication:** No.

**User Admin:** No.

**Phone Support** Note that support for particular phone models is also dependant on the system software level.

Analog: ✗	20 Series: ✗	4100 Series: ✗	6400 Series: ✓	D100: ✓
1100 Series: ✓	2400 Series: ✓	4400 Series: ✓	7400 Series: ✗	M-Series: ✓ [1]
1200 Series: ✓	3600 Series: ✓	4600 Series: ✓	9040: ✓	T-Series: ✓ [1]
1400 Series: ✓	3700 Series: ✗	5400 Series: ✓	9500 Series: ✓	T3/T3 IP Series: ✗
1600 Series: ✓	3810: ✓	5600 Series: ✓	9600 Series: ✓	

1. Not supported on T7000, T7100, M7100, M7100N and the Audio Conferencing Unit (ACU).

---

## Stored Number View

Not supported. Provided for CTI emulation only. Allows a user to view the contents of any programmed feature button.

**Action:** Emulation | Stored Number View.

**Action Data:** None.

**Default Label:** BtnVu.

**Toggles:** No.

**Status Indication:** No.

**User Admin:** No.

**Phone Support** Note that support for particular phone models is also dependant on the system software level.

Analog: ✗	20 Series: ✔	4100 Series: ✗	6400 Series: ✔	D100: ✗
1100 Series: ✗	2400 Series: ✔ [1]	4400 Series: ✔	7400 Series: ✗	M-Series: ✗
1200 Series: ✗	3600 Series: ✗	4600 Series: ✔ [1]	9040: ✔	T-Series: ✗
1400 Series: ✔ [1]	3700 Series: ✗	5400 Series: ✔	9500 Series: ✗	T3/T3 IP Series: ✗
1600 Series: ✔ [1]	3810: ✔	5600 Series: ✔ [1]	9600 Series: ✗	

1. Not 1403, 1603, 2402, 4601, 4602, 5601 and 5602 except where 4602 is supported on Release 2.1 and 3.0DT software.

## Suspend Call

Uses the Q.931 Suspend facility. Suspends the incoming call at the ISDN exchange, freeing up the ISDN B channel. The call is placed in exchange slot 0 if a slot number is not specified. Only available when supported by the ISDN exchange.

**Action:** Advanced | Suspend | Suspend.

**Action Data:** Exchange slot number or blank (slot 0).

**Default Label:** Suspe.

**Toggles:** No.

**Status Indication:** No.

**User Admin:** No.

**Phone Support** Note that support for particular phone models is also dependant on the system software level.

Analog: ✗	20 Series: ✔	4100 Series: ✗	6400 Series: ✔	D100: ✗
1100 Series: ✗	2400 Series: ✔ [1]	4400 Series: ✔	7400 Series: ✗	M-Series: ✗
1200 Series: ✗	3600 Series: ✗	4600 Series: ✔ [1]	9040: ✔	T-Series: ✗

*Table continues...*

1400 Series: ✓ [1]	3700 Series: ✗	5400 Series: ✓	9500 Series: ✗	T3/T3 IP Series: ✗
1600 Series: ✓ [1]	3810: ✓	5600 Series: ✓ [1]	9600 Series: ✗	

1. Not 1403, 1603, 2402, 4601, 4602, 5601 and 5602 except where 4602 is supported on Release 2.1 and 3.0DT software.

---

## Suspend CW

Uses the Q.931 Suspend facility. Suspends the incoming call at the ISDN exchange and answer the call waiting. The call is placed in exchange slot 0 if a slot number is not specified. Only available when supported by the ISDN exchange.

**Action:** Advanced | Suspend | Suspend CW.

**Action Data:** Exchange slot number or blank (slot 0).

**Default Label:** SusCW.

**Toggles:** No.

**Status Indication:** No.

**User Admin:** No.

**Phone Support** Note that support for particular phone models is also dependant on the system software level.

Analog: ✗	20 Series: ✓	4100 Series: ✗	6400 Series: ✓	D100: ✗
1100 Series: ✗	2400 Series: ✓ [1]	4400 Series: ✓	7400 Series: ✗	M-Series: ✗
1200 Series: ✗	3600 Series: ✗	4600 Series: ✓ [1]	9040: ✓	T-Series: ✗
1400 Series: ✓ [1]	3700 Series: ✗	5400 Series: ✓	9500 Series: ✗	T3/T3 IP Series: ✗
1600 Series: ✓ [1]	3810: ✓	5600 Series: ✓ [1]	9600 Series: ✗	

1. Not 1403, 1603, 2402, 4601, 4602, 5601 and 5602 except where 4602 is supported on Release 2.1 and 3.0DT software.

---

## Swap CLID Name/Number

Allows the user to toggle between Caller Name and Caller ID.

**Action:** Emulation | Swap CLID Name/Number

**Action Data:** None.

**Default Label:**

**Toggles:** Yes.

**Status Indication:** No.

**User Admin:** No.

**Phone Support:** Note that support for particular phone models is also dependant on the system software level.

<b>Analog:</b> No	<b>20 Series:</b> No	<b>4100 Series:</b> No [1]	<b>64000:</b> No	<b>D100:</b> No
<b>1100 Series:</b> No	<b>2400 Series:</b> No	<b>4400 Series:</b> No	<b>7400 Series:</b> No	<b>M-Series:</b> Yes
<b>1200 Series:</b> No	<b>3600 Series:</b> No	<b>4600 Series:</b> No	<b>9040 Series:</b> No	<b>T-Series:</b> Yes
<b>1400 Series:</b> No	<b>3700 Series:</b> No	<b>5400 Series:</b> No	<b>9500 Series:</b> No	<b>T3/T3 IP Series:</b> No
<b>1600 Series:</b> No	<b>3810 Series:</b> No	<b>5600 Series:</b> No	<b>9600 Series:</b> No	

## Time of Day

Displays the time and date on the user's telephone. This function is ignored on those Avaya phones that display the date/time by default.



**Action:** Emulation | Time of Day.

**Action Data:** None.

**Default Label:** TmDay.

**Toggles:** Yes.

**Status Indication:** Yes.

<b>Status</b>	<b>2400, 5400 Series</b>	<b>4600, 5600 Series</b>	1400, 1600, 4400, 6400, 9500 Series	9600 Series	9608, 9611, J139, J159, J169, J179, J189	9621, 9641	<b>T-Series, M-Series</b>
- On.	<Label> ◀	<Label>	<b>Green on</b>	<b>Red on</b>	<b>Green on</b>	 <b>Green</b>	 <b>On</b>
- Off.	<Label>	<Label>	Off	Off	Off	 <b>Grey</b>	Off

**User Admin:** Yes.

**Phone Support** Note that support for particular phone models is also dependant on the system software level.

<b>Analog:</b> No	<b>20 Series:</b> Yes	<b>4100 Series:</b> No	<b>6400 Series:</b> Yes	<b>D100:</b> : No
<b>1100 Series:</b> No	<b>2400 Series:</b> Yes [1]	<b>4400 Series:</b> Yes	<b>7400 Series:</b> No	<b>M-Series:</b> Yes

*Table continues...*

<b>1200 Series:</b> No	<b>3600 Series:</b> Yes	<b>4600 Series:</b> Yes [1]	<b>9040:</b> Yes	<b>T-Series:</b> Yes
<b>1400 Series:</b> Yes [1]	<b>3700 Series:</b> No	<b>5400 Series:</b> Yes [1]	<b>9500 Series:</b> Yes	<b>T3/T3 IP Series:</b> No
<b>1600 Series:</b> Yes [1]	<b>3810:</b> No	<b>5600 Series:</b> Yes [1]	<b>9600 Series:</b> No	

1. Not 1403, 1603, 2402, 4601, 4602, 5402, 5601 and 5602 models.

---

## Time Profile

You can manually override a time profile. The override settings allow you to mix timed and manual settings.

The button indicator will show the Time Profile state and pressing the button will present a menu with five options and an indication of the current state. The menu options are listed below.

Menu Option	Description
<b>Timed Operation</b>	No override. The time profile operates as configured.
<b>Active Until Next Timed Inactive</b>	Use for time profiles with multiple intervals. Select to make the current timed interval active until the next inactive interval.
<b>Inactive Until Next Timed Active</b>	Use for time profiles with multiple intervals. Select to make the current active timed interval inactive until the next active interval.
<b>Latch Active</b>	Set the time profile to active. Timed inactive periods are overridden and remain active.
<b>Latch Inactive</b>	Set the time profile to inactive. Timed active periods are overridden and remain inactive.

## Button Programming Actions

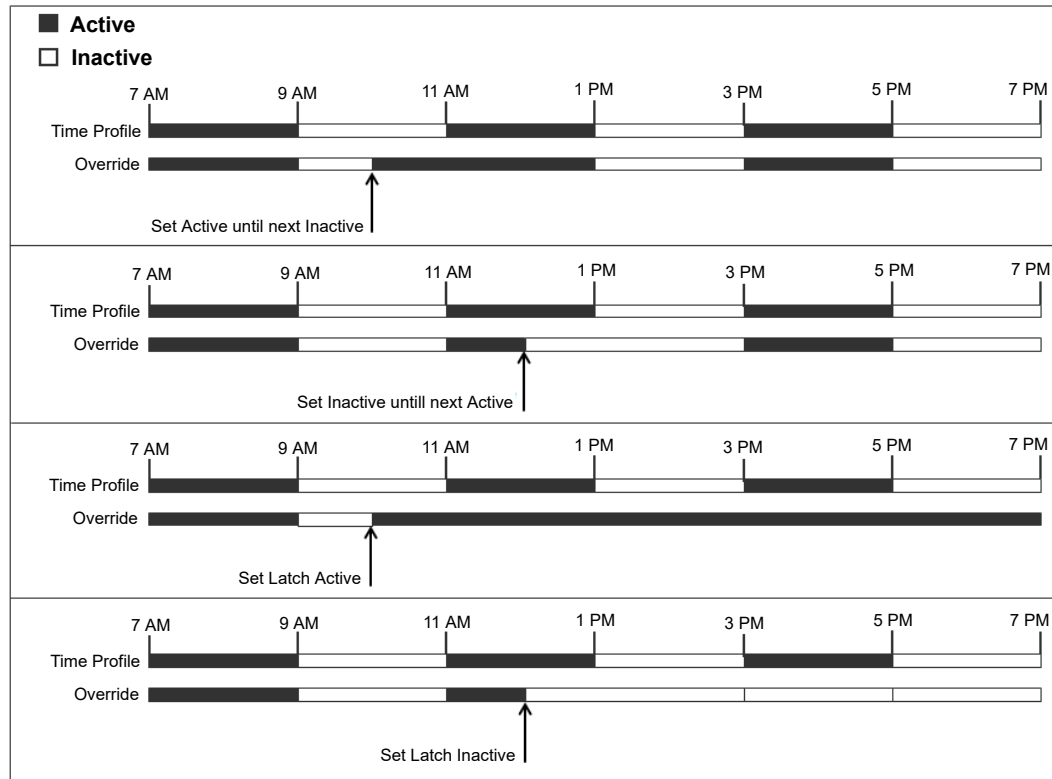

**Action:** Emulation | Time Profile

**Action Data:** Time profile name.

**Default Label:** TP or Time Profile

**Toggles:** No.

**Status Indication:**

Status	1400, 1600,	9600 Series	9608, 9611, J139, J159, J169, J179, J189	9621, 9641
On	Green	Red on	Green On	<span style="color: green;">■</span> Green
Off	Off	Off	Off	<span style="background-color: grey;">■</span> Grey

**User Admin:** No

**Phone Support:** Note that support for particular phone models is also dependant on the system software level.

<b>Analog:</b>	<b>20 Series:</b> No	<b>4100 Series:</b> No	<b>6400 Series:</b> No	<b>D100:</b> No
----------------	----------------------	------------------------	------------------------	-----------------

*Table continues...*



<b>1100 Series:</b> No	<b>2400 Series:</b> No	<b>4400 Series:</b> No	<b>7400 Series:</b> No	<b>M-Series:</b> No
<b>1200 Series:</b> No	<b>3600 Series:</b> No	<b>4600 Series:</b> No	<b>9040:</b> No	<b>T-Series:</b> No
<b>1400 Series:</b> Yes	<b>3700 Series:</b> No	<b>5400 Series:</b> No	<b>9500 Series:</b> No	<b>T3/T3 IP Series:</b> No
<b>1600 Series:</b> Yes	<b>3810:</b> No	<b>5600 Series:</b> No	<b>9600 Series:</b> Yes	

## Timer

Starts a timer running on the display of the user's extension. The timer disappears when the user ends a call.

This function can be used on Avaya phones (except 9600 Series) that display a call timer next to each call appearance. The button will temporarily turn the call timer on or off for the currently selected call appearance. The change only applies for the duration of the current call.

**Action:** Emulation | Timer.

**Action Data:** None.

**Default Label:** Timer.

**Toggles:** Yes.

**Status Indication:** Yes.

Status	2400, 5400 Series	4600, 5600 Series	4400, 6400 Series	1400, 1600, 9500 Series	9600 Series	9608, 9611, J139, J159, J169, J179, J189	9621, 9641	T-Series, M-Series
- On.	<Label> ▲	<Label>	Green on	Off	–	–	–	▲ On
- Off.	<Label>	<Label>	Off	Off	–	–	–	Off

**User Admin:** Yes.

**Phone Support** Note that support for particular phone models is also dependant on the system software level.

<b>Analog:</b> No	<b>20 Series:</b> Yes	<b>4100 Series:</b> No	<b>6400 Series:</b> Yes	<b>D100:</b> No
<b>1100 Series:</b> No	<b>2400 Series:</b> Yes [1]	<b>4400 Series:</b> Yes	<b>7400 Series:</b> No	<b>M-Series:</b> Yes
<b>1200 Series:</b> No	<b>3600 Series:</b> Yes	<b>4600 Series:</b> Yes [1]	<b>9040:</b> Yes	<b>T-Series:</b> Yes

*Table continues...*

<b>1400 Series:</b> Yes [1]	<b>3700 Series:</b> No	<b>5400 Series:</b> Yes [1]	<b>9500 Series:</b> Yes	<b>T3/T3 IP Series:</b> No
<b>1600 Series:</b> Yes [1]	<b>3810:</b> No	<b>5600 Series:</b> Yes [1]	<b>9600 Series:</b> Yes [2]	

1. Not 1403, 1603, 2402, 4601, 4602, 5402, 5601 and 5602 models.
2. Supported on 9608, 9611, 9621, and 9641 phones.

## Transfer

This function is intend for use with Avaya M-Series and T-Series phones only. When pressed, the button invokes the same transfer process as dialing **Feature 70**.

**Action:** Advanced | Call | Transfer.

**Action Data:** None.

**Default Label:** Xfer.

**Toggles:** No.

**Status Indication:** No.

User Admin: No.

**Phone Support** This function is only supported on Avaya M-Series and T-Series phones.

## Toggle Calls

Cycle between the user's current call and any held calls.

**Action:** Advanced | Call | Toggle Calls..

**Action Data:** None.

**Default Label:** Toggl.

**Toggles:** No.

**Status Indication:** No.

**User Admin:** No.

**Phone Support** Note that support for particular phone models is also dependant on the system software level.

<b>Analog:</b> ✗	<b>20 Series:</b> ✓	<b>4100 Series:</b> ✗	<b>6400 Series:</b> ✓	<b>D100:</b> ✗
------------------	---------------------	-----------------------	-----------------------	----------------

*Table continues...*

1100 Series: ✗	2400 Series: ✔ [1]	4400 Series: ✔	7400 Series: ✗	M-Series: ✗
1200 Series: ✗	3600 Series: ✗	4600 Series: ✔ [1]	9040: ✔	T-Series: ✗
1400 Series: ✔ [1]	3700 Series: ✗	5400 Series: ✔	9500 Series: ✗	T3/T3 IP Series: ✗
1600 Series: ✔ [1]	3810: ✔	5600 Series: ✔ [1]	9600 Series: ✗	

1. Not 1403, 1603, 2402, 4601, 4602, 5601 and 5602 except where 4602 is supported on Release 2.1 and 3.0DT software.

---

## Twinning

This action can be used by user's setup for mobile twinning. This action is not used for internal twinning.

While the phone is idle, the button allows the user to set and change the destination for their twinned calls. It can also be used to switch mobile twinning on/off and indicates the status of that setting.

When a call has been routed by the system to the user's twinned destination, the **Twinning** button can be used to retrieve the call at the user's primary extension.

In configurations where the call arrives over an IP trunk and the outbound call is on an IP trunk, multi-site network may optimise the routing and in this case the button may not be usable to retrieve the call.

For user's setup for one-X Mobile Client, changes to their Mobile Twinning status made through the system configuration or using a **Twinning** button are not reflected in the status of the **Extension to Cellular** icon on their mobile client. However, changes to the **Extension to Cellular** status made from the mobile client are reflected by the **Mobile Twinning** field in the system configuration. Therefore, for one-X Mobile Client users, it is recommended that they control their Mobile Twinning status through the one-X Mobile Client rather than through a **Twinning** button.

**Mobile Twinning Handover** When on a call on the primary extension, pressing the **Twinning** button will make an unassisted transfer to the twinning destination. This feature can be used even if the user's **Mobile Twinning** setting was not enabled.

During the transfer process the button will wink. Pressing the twinning button again will halt the transfer attempt and reconnect the call at the primary extension.

The transfer may return if it cannot connect to the twinning destination or is unanswered within the user's configured **Transfer Return Time** (if the user has no **Transfer Return Time** configured, a enforced time of 15 seconds is used).

- **Action:** Emulation | Twinning.
- **Action Data:** None.
- **Default Label:** Twinning.
- **Toggles:** Yes.

- **Status Indication:** Yes.

Status	2400, 5400 Series	4600, 5600 Series	1400, 1600, 4400, 6400, 9500 Series	9600 Series	9608, 9611, J139, J159, J169, J179, J189	9621, 9641	T-Series, M-Series
- On.	Twinning ◀	Twinning	Green on	Red on	Green on	■ Green	▲ On
- Off.	Twinning	Twinning	Off	Off	Off	■ Grey	Off
- Twinned call at secondary	Twinning ◀	Twinning ◆	Red on	Red flash	Red on	■ Blue	▲ On

- **User Admin:** No.

- **Phone Support** Note that support for particular phone models is also dependant on the system software level.

Analog: ✗	20 Series: ✓	4100 Series: ✗	6400 Series: ✓	M-Series: ✓
1100 Series: ✓	2400 Series: ✓ [1]	4400 Series: ✓	7400 Series: ✗	T-Series: ✓
1200 Series: ✓	3600 Series: ✓	4600 Series: ✓ [1]	9040: ✓	T3/T3 IP Series: ✗
1400 Series: ✓ [1]	3700 Series: ✗	5400 Series: ✓ [1]	9500 Series: ✓	Vantage Connect Expansion: ✓
1600 Series: ✓ [1]	3810: ✗	5600 Series: ✓ [1]	D100: ✓	

1. Not 1403, 1603, 2402, 4601, 4602, 5402, 5601 and 5602 models.

## Unpark Call

This function is obsolete, since the Call Park function can be used to both park and retrieve calls and provides visual indication of when calls are parked. Retrieve a parked call from a specified system park slot.

**Action:** Advanced | Call | Unpark Call.

**Action Data:** System park slot number. This must match a park slot ID used to park the call.

**Default Label:** UnPark.

**Toggles:** No.

**Status Indication:** No.

**User Admin:** No.

**Phone Support** Note that support for particular phone models is also dependant on the system software level.

Analog: ✗	20 Series: ✓	4100 Series: ✗	6400 Series: ✓	D100: ✗
1100 Series: ✗	2400 Series: ✓ [1]	4400 Series: ✓	7400 Series: ✗	M-Series: ✗
1200 Series: ✗	3600 Series: ✗	4600 Series: ✓ [1]	9040: ✓	T-Series: ✗
1400 Series: ✓ [1]	3700 Series: ✗	5400 Series: ✓	9500 Series: ✗	T3/T3 IP Series: ✗ [2]
1600 Series: ✓ [1]	3810: ✓	5600 Series: ✓ [1]	9600 Series: ✗	

1. Not 1403, 1603, 2402, 4601, 4602, 5601 and 5602 except where 4602 is supported on Release 2.1 and 3.0DT software.
2. Limited support on some specific T3 phone models as detailed below.

M-Series/T-Series: The button is equivalent to **Feature #74 <park slot number>**.

## User

Monitors whether another user's phone is idle or in use. The **Telephone Number** field should contain the users name enclosed in double quotes. The button can be used to make calls to the user or pickup their longest waiting call when ringing. On buttons with a text label, the user name is shown.

The actions performed when the button is pressed will depend on the state of the target user and the type of phone being used. It also depend on whether the user is local or on a remote multi-site network system.

Phone	Large display 1400, 1600, 2400, 4600, 5400, 5600, 9500, 9600, M-Series and T-Series Phones	Other Phones or across a multi-site network
<b>Idle</b>	Call the user. Whilst ringing the phone displays options to <b>Callback</b> (set an automatic callback ) and <b>Drop</b> (end the call attempt).	
<b>Ringing</b>	<ul style="list-style-type: none"> <li>• <b>Call Pickup:</b> Pickup the ringing call.</li> <li>• <b>Call:</b> Make a call to the user.</li> </ul>	Picks up the call.
<b>On a Call</b>	<p>The following options are displayed (name lengths may vary depending on the phone display):</p> <ul style="list-style-type: none"> <li>• <b>Call:</b> Make a call to the user.</li> <li>• <b>Message:</b> Cause a single burst of ringing on the target phone. On some phones, when they end their current call their phone will then display PLEASE CALL and your extension number.</li> <li>• <b>Voicemail:</b> Call the user's voicemail mailbox.</li> <li>• <b>Callback:</b> Set an automatic callback.</li> </ul>	<p>No action.</p> <p>For 1400, 1600, 9500 and 9600 Series phones, the <b>Call, Voicemail</b> and <b>Callback</b> options are supported.</p>

*Table continues...*

	<p>For 1400, 1600, 9500 and 9600 Series phones the following additional options are displayed:</p> <ul style="list-style-type: none"> <li>• <b>Drop</b> Disconnect the user's current call.</li> <li>• <b>Acquire:</b> Shown if able to intrude on the user. Take control of the call.</li> <li>• <b>Intrude:</b> Shown if able to intrude on the user. Intrude into the call, turning it into a 3-way conference.</li> <li>• <b>Listen:</b> Shown if configured to be able to listen to (monitor) the user. Start silent monitoring of the user's call.</li> </ul>	
--	---------------------------------------------------------------------------------------------------------------------------------------------------------------------------------------------------------------------------------------------------------------------------------------------------------------------------------------------------------------------------------------------------------------------------------------------------------------------------------------------------------------------------------------------------------------------	--

A User button can be used in conjunction with other buttons to indicate the target user when those buttons have been configured with no pre-set user target. In cases where the other button uses the phone display for target selection this is only possible using **User** buttons on an associate button module.

The following changes have been made to the indication of user status via BLF (busy lamp field) indicators such as a User button:

The status shown for a logged out user without mobile twinning will depend on whether they have **Forward Unconditional** enabled.

- If they have **Forward Unconditional** enabled the user is shown as idle.
- If they do not have **Forward Unconditional** enabled they will show as if on DND.

The status shown for a logged out user with mobile twinning will be as follows:

- If there are any calls alerting or in progress through the system to the twinned destination, the user status is shown as alerting or in-use as appropriate. This includes the user showing as busy/in-use if they have such a call on hold and they have **Busy on Held** enabled.
- If the user enables DND through Mobile Call Control or one-X Mobile client, their status will show as DND.
- Calls from the system direct to the user's twinned destination number rather than redirected by twinning will not change the user's status.









**Action:** User.

**Action Data:** User name enclosed in "double-quotes".

**Default Label:** <the user name>.

**Toggles:** No.

**Status Indication:** Yes.

Status	2400 Series, 5400 Series	4600 Series, 5600 Series	4400 Series, 6400 Series	1400 Series, 1600 Series, 9500 Series	9600 Series	9608, 9611, J139, J159, J169, J179, J189	9621, 9641	T-Series, M-Series
- Idle.	Extn221	Extn221	Off	Off	Off	Off	 Grey	Off
- Alerting.	Extn221 	Extn221 	Green flash	Red flash	Red flash	Red flash	 Blue	 Slow flash
- In Use/ Busy.	Extn221	Extn221	Green on	Red wink	Red wink	Red wink	 Blue	 Fast flash
- DND	Extn221	Extn221	Green on	Red on	Red on	Red on	 Green	 On

User Admin: No.

**Phone Support** Note that support for particular phone models is also dependant on the system software level.

Analog: No	20 Series: Yes	4100 Series: No	6400 Series: Yes	D100: No
1100 Series: No	2400 Series: Yes [1]	4400 Series: Yes	7400 Series: No	M-Series: Yes
1200 Series: No	3600 Series: Yes	4600 Series: Yes [1]	9040: Yes	T-Series: Yes
1400 Series: Yes [1]	3700 Series: No	5400 Series: Yes	9500 Series: Yes	T3/T3 IP Series: No [2]
1600 Series: Yes [1]	3810: Yes	5600 Series: Yes [1]	9600 Series: Yes	

1. Not 1403, 1603, 4601, 4602, 5601 and 5602 except where 4602 is supported on Release 2.1 and 3.0DT software.
2. Limited support on some specific T3 phone models as detailed below.

#### T3 Phones:

- **Classic/Comfort icon:** Displays the user name.
- **DSS Link LED:** On when busy, flashing when call alerting user.

---

## Visual Voice

This action provides the user with a menu for access to voicemail mailboxes. The menu provides the user with options for listening to messages, leaving messages and managing the mailbox. If no action data is specified, then it is the user's mailbox. Action Data can be used to specify the mailbox of another user or group.

**\* Note:**

You can also use the “H” and “U” user source numbers to add another mailbox to your Visual Voice menu. See **User | Source Numbers**

If the Action Data has been configured, pressing the button for an incoming call or while a call is connected sends the call to the user mailbox specified in the action data. If no Action Data is configured, the user is prompted to enter a mailbox.

On phones that have a display but do not support full visual voice operation as indicated below, use of the button for user mailbox access using voice prompts and for direct to voicemail transfer during a call is supported (does not include T3 and T3 IP phones).

Access to Visual Voice on supported phones can be triggered by the phone's **MESSAGES** button rather than requiring a separate Visual Voice programmable button. This is done using the option **System | Voicemail | Messages button goes to Visual Voice**.

**Action:** Emulation | Visual Voice.

**Action Data:** All local users and groups and all users and groups on systems in the network, except for the user on which the button is being programmed.

**Default Label:** Voice.

**Toggles:** No.

**Status Indication:** When action data is configured, the status lamp provides a message waiting indicator for the monitored mailbox.

**User Admin:** No.

Phone Support Note that support for particular phone models is also dependant on the system software level.

<b>Analog:</b> No	<b>20 Series:</b> No	<b>4100 Series:</b> No	<b>6400 Series:</b> No	<b>D100:</b> No
<b>1100 Series:</b> No	<b>2400 Series:</b> Yes [1]	<b>4400 Series:</b> Yes	<b>7400 Series:</b> No	<b>M-Series:</b> No
<b>1200 Series:</b> No	<b>3600 Series:</b> No	<b>4600 Series:</b> Yes [1]	<b>9040:</b> Yes	<b>T-Series:</b> No
<b>1400 Series:</b> Yes	<b>3700 Series:</b> No	<b>5400 Series:</b> Yes [1]	<b>9500 Series:</b> Yes	<b>T3/T3 IP Series:</b> Yes [2]
<b>1600 Series:</b> Yes	<b>3810:</b> No	<b>5600 Series:</b> Yes [1]	<b>9600 Series:</b> No	

1. Not 1403, 1603, 2402, 5402, 4601, 4602, 5601 and 5602.
2. Takes the user direct to the listen part of Visual Voice. For the full Visual Voice menu options the user should use **Menu | Settings | Voicemail Settings**.

**Visual Voice Controls**

The arrangement of options on the screen will vary depending on the phone type and display size.

**Listen** Access your own voicemail mailbox. When pressed the screen will show the number of **New**, **Old** and **Saved** messages. Select one of those options to start playback of messages in that



category. Use the ▲ up arrow and ▼ arrow keys to move through the message. Use the options below.

**Listen** Play the message.

**Pause** Pause the message playback.

**Delete** Delete the message.

**Save** Mark the message as a saved message.

**Call** Call the message sender if a caller ID is available.

**Copy** Copy the message to another mailbox. When pressed a number of additional options are displayed.

**Message** Record and send a voicemail message to another mailbox or mailboxes.

**Greeting** Change the main greeting used for callers to your mailbox. If no greeting has been recorded then the default system mailbox greeting is used.

**Mailbox Name** Record a mailbox name. This feature is only available on systems using Embedded Voicemail.

**Email** This option is only shown if you have been configured with an email address for voicemail email usage in the system configuration. This control allows you to see and change the current voicemail email mode being used for new messages received by your voicemail mailbox. Use **Change** to change the selected mode. Press **Done** when the required mode is displayed. Possible modes are:

**Password** Change the voicemail mailbox password. To do this requires entry of the existing password.

**Voicemail** Switch voicemail coverage on/off.

---

## Voicemail Collect

Connects to the voicemail server. The telephone number must indicate the name of the Voicemail box to be accessed, eg. "?Extn201" or "#Extn201". The ? indicates "collect Voicemail" and the # indicates "deposit Voicemail". This action is not supported by voicemail using Intuity emulation mode.

When used with Voicemail Pro, names of specific call flow start points can also be used to directly access those start points via a short code. In these cases ? is not used and # is only used if ringing is required before the start points call flow begins.

**Action:** Advanced | Voicemail | Voicemail Collect.

**Action Data:** See above.

**Default Label:** VMCol or VMail Collect.

**Toggles:** No.

**Status Indication:** No.

**User Admin:** No.

**Phone Support** Note that support for particular phone models is also dependant on the system software level.

Analog: ✗	20 Series: ✓	4100 Series: ✗	6400 Series: ✓	D100: ✗
1100 Series: ✗	2400 Series: ✓ [1]	4400 Series: ✓	7400 Series: ✗	M-Series: ✓
1200 Series: ✗	3600 Series: ✗	4600 Series: ✓ [1]	9040: ✓	T-Series: ✓
1400 Series: ✓ [1]	3700 Series: ✗	5400 Series: ✓	9500 Series: ✓	T3/T3 IP Series: ✗ [2]
1600 Series: ✓ [1]	3810: ✓	5600 Series: ✓ [1]	9600 Series: ✓	

1. Not 1403, 1603, 4601, 4602, 5601 and 5602 except where 4602 is supported on Release 2.1 and 3.0DT software.
2. Limited support on some specific T3 phone models as detailed below.

M-Series/T-Series: For access to the users own mailbox, this button is equivalent to **Feature 65** and **Feature 981**.

## Voicemail Off

Disables the user's voicemail box from answering calls that ring unanswered at the users extension. This does not disable the user's mailbox and other methods of placing messages into their mailbox.

This button function is obsolete as the Voicemail On function toggles on/off.

**Action:** Advanced | Voicemail | Voicemail Off.

**Action Data:** None.

**Default Label:** VMOff.

**Toggles:** No.

**Status Indication:** No.

**User Admin:** No.

**Phone Support** Note that support for particular phone models is also dependant on the system software level.

Analog: ✗	20 Series: ✓	4100 Series: ✗	6400 Series: ✓	D100: ✓
1100 Series: ✓	2400 Series: ✓ [1]	4400 Series: ✓	7400 Series: ✗	M-Series: ✓
1200 Series: ✓	3600 Series: ✗	4600 Series: ✓ [1]	9040: ✓	T-Series: ✓
1400 Series: ✓ [1]	3700 Series: ✗	5400 Series: ✓	9500 Series: ✓	T3/T3 IP Series: ✗

*Table continues...*

1600 Series: ✓ [1]	3810: ✓	5600 Series: ✓ [1]	9600 Series: ✓	
--------------------	---------	--------------------	----------------	--

1. Not 1403, 1603, 4601, 4602, 5601 and 5602 except where 4602 is supported on Release 2.1 and 3.0DT software.

## Voicemail On

Enables the user's voicemail mailbox to answer calls which ring unanswered or arrive when the user is busy.

- **Action:** Advanced | Voicemail | Voicemail On.
- **Action Data:** None.
- **Default Label:** VMOn or VMail On.
- **Toggles:** Yes.
- **Status Indication:** Yes.

Status	2400, 5400 Series	4600, 5600 Series	1400, 1600, 4400, 6400, 9500 Series	9600 Series	9608, 9611, J139, J159, J169, J179, J189	9621, 9641	T-Series, M-Series
- On.	<Label> ◀	<Label>	Green on	Red on	Green on	■ Green	▲ On
- Off.	<Label>	<Label>	Off	Off	Off	■ Grey	Off

- **User Admin:** No.
- **Phone Support** Note that support for particular phone models is also dependant on the system software level.

Analog: ✗	20 Series: ✓	4100 Series: ✗	6400 Series: ✓	D100: ✓
1100 Series: ✓	2400 Series: ✓ [1]	4400 Series: ✓	7400 Series: ✗	M-Series: ✓
1200 Series: ✓	3600 Series: ✗	4600 Series: ✓ [1]	9040: ✓	T-Series: ✓
1400 Series: ✓ [1]	3700 Series: ✗	5400 Series: ✓	9500 Series: ✓	T3/T3 IP Series: ✗ [2]
1600 Series: ✓ [1]	3810: ✓	5600 Series: ✓ [1]	9600 Series: ✓	Vantage Connect Expansion: ✓

1. Not 1403, 1603, 4601, 4602, 5601 and 5602 except where 4602 is supported on Release 2.1 and 3.0DT software.
2. Limited support on some specific T3 phone models as detailed below.

**T3 Phones:** Supported on Avaya T3 Classic, Comfort and Compact phones for Release 4.2+.

- **Classic/Comfort icon:** Displays 📞➡️✉️. The background uses the same settings as the LED below.
- **DSS Link LED:** On when set.

## Voicemail Ringback Off

Disables voicemail ringback to the user's extension. This button function is obsolete as the Voicemail Ringback On function toggles on/off.

**Action:** Advanced | Voicemail | Voicemail Ringback Off.

**Action Data:** None.

**Default Label:** VMRB-

**Toggles:** No.

**Status Indication:** No.

**User Admin:** No.

**Phone Support** Note that support for particular phone models is also dependant on the system software level.

Analog: ✗	20 Series: ✔	4100 Series: ✗	6400 Series: ✔	D100: ✗
1100 Series: ✗	2400 Series: ✔ [1]	4400 Series: ✔	7400 Series: ✗	M-Series: ✗
1200 Series: ✗	3600 Series: ✗	4600 Series: ✔ [1]	9040: ✔	T-Series: ✗
1400 Series: ✔ [1]	3700 Series: ✗	5400 Series: ✔	9500 Series: ✗	T3/T3 IP Series: ✗
1600 Series: ✔ [1]	3810: ✔	5600 Series: ✔ [1]	9600 Series: ✗	

1. Not 1403, 1603, 2402, 4601, 4602, 5601 and 5602 except where 4602 is supported on Release 2.1 and 3.0DT software.

## Voicemail Ringback On

Enables voicemail ringback to the user's extension. Voicemail ringback is used to call the user when they have new voicemail messages in their own mailbox or a hunt group mailbox for which they have been configured with message waiting indication.

The ringback takes place when the user's phone returns to idle after any call is ended.

**Action:** Advanced | Voicemail | Voicemail Ringback On.

**Action Data:** None.

**Default Label:** VMRB+ or VMail Ringback.

**Toggles:** Yes.

**Status Indication:** Yes.

Status	2400, 5400 Series	4600, 5600 Series	1400, 1600, 4400, 6400, 9500 Series	9600 Series	9608, 9611, J139, J159, J169, J179, J189	9621, 9641	T-Series, M-Series
- On.	<Label> ◀	<Label>	Green on	Red on	Green on	■ Green	▲ On
- Off.	<Label>	<Label>	Off	Off	Off	■ Grey	Off

**User Admin:** No.

**Phone Support** Note that support for particular phone models is also dependant on the system software level.

Analog: ✗	20 Series: ✓	4100 Series: ✗	6400 Series: ✓	D100: ✗
1100 Series: ✗	2400 Series: ✓ [1]	4400 Series: ✓	7400 Series: ✗	M-Series: ✓
1200 Series: ✗	3600 Series: ✗	4600 Series: ✓ [1]	9040: ✓	T-Series: ✓
1400 Series: ✓ [1]	3700 Series: ✗	5400 Series: ✓	9500 Series: ✓	T3/T3 IP Series: ✗
1600 Series: ✓ [1]	3810: ✓	5600 Series: ✓ [1]	9600 Series: ✓	

1. Not 1403, 1603, 4601, 4602, 5601 and 5602 except where 4602 is supported on Release 2.1 and 3.0DT software.

---

## Whisper Page

This feature allows you to intrude on another user and be heard by them without being able to hear the user's existing call which is not interrupted. For example: User A is on a call with user B. When user C intrudes on user A, they can be heard by user A but not by user B who can still hear user A. Whisper page can be used to talk to a user who has enabled private call.

The ability to intrude and be intruded is controlled by two configuration settings, the Can Intrude (User | Telephony | Supervisor Settings) setting of the user intruding and the Cannot Be Intruded (User | Telephony | Supervisor Settings) setting of target being intruded on. The setting of any other internal party is ignored. By default, no users can intrude and all users are set to cannot be intruded.

The system support a range of other call intrusion methods in addition to this feature.

**Action:** Advanced | Call | Whisper Page.

**Action Data:** User number or name or blank for entry when pressed.

**Default Label:** Whisp or Whisper Page.

**Toggles:** No.

**Status Indication:** No.

**User Admin:** No.

**Phone Support** Note that support for particular phone models is also dependant on the system software level.

Analog: ✗	20 Series: ✗	4100 Series: ✗	6400 Series: ✗	D100: ✗
1100 Series: ✗	2400 Series: ✗	4400 Series: ✗	7400 Series: ✗	M-Series: ✗
1200 Series: ✗	3600 Series: ✗	4600 Series: ✗	9040: ✗	T-Series: ✗
1400 Series: ✓ [1] [2]	3700 Series: ✗	5400 Series: ✗	9500 Series: ✓ [2]	T3/T3 IP Series: ✗
1600 Series: ✓ [1]	3810: ✗	5600 Series: ✗	9600 Series: ✓	

1. Not 1403, 1603.
2. Not supported on non-IP telephones when using a headset.

# Chapter 21: Appearance Button Operation

Many Avaya phones supported on system have a programmable keys or buttons (the terms 'key' and 'button' mean the same thing in this context). Various actions can be assigned to each of these keys, allowing the phone user to access that action.

Many of the phones also have indicator lamps next to the programmable buttons. These lamps are used to indicate the status of the button, for example 'on' or 'off'. On other phones the programmable buttons use an adjacent area of the phones display to show status icons and text labels for the buttons.

**Example** The example below shows the display and programmable buttons on an Avaya 5421 phone where a number of programmable features have been assigned to the user.

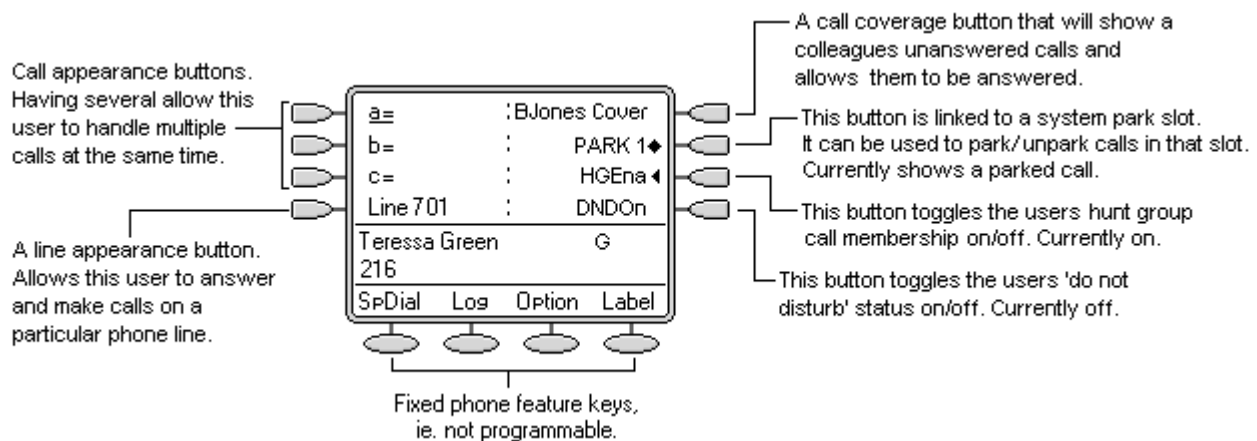

This type of phone displays text labels for the programmed features. On other phones a paper label may have to be updated to indicate the programmed feature.

The system supports the following 'appearance' actions - Call Appearance, Bridged Appearance, Line Appearance and Call Coverage Appearance. These actions can be assigned to the programmable buttons on a user's phone. Those 'appearance' buttons can then be used to answer, share, switch between and in some case make calls. This type of call handling is often called 'key and lamp mode'.

This document covers the programming and operation of phones using the appearance functions. Details of the other actions that can be assigned to programmable keys are covered in Button Programming.

**\* Note:**

For all the examples within this documentation, it is assumed that **Auto Hold** is on and **Answer Pre-Select** is off unless otherwise stated.

The text shown on phone displays are typical and may vary between phone types, locales and system software releases.

**Related links**

- [Appearance Button Features](#) on page 1080
- [Call Appearance Buttons](#) on page 1081
- [Bridged Appearance Buttons](#) on page 1086
- [Call Coverage Buttons](#) on page 1091
- [Line Appearance Buttons](#) on page 1095
- [Selected Button Indication](#) on page 1101
- [Idle Line Preference](#) on page 1102
- [Ringing Line Preference](#) on page 1104
- [Answer Pre-Select](#) on page 1106
- [Auto Hold](#) on page 1108
- [Ring Delay](#) on page 1108
- [Delayed Ring Preference](#) on page 1110
- [Collapsing Appearances](#) on page 1112
- [Joining Calls](#) on page 1113
- [Multiple Alerting Appearance Buttons](#) on page 1115
- [Twinning](#) on page 1116
- [Busy on Held](#) on page 1117
- [Reserving a Call Appearance Button](#) on page 1117
- [Logging Off and Hot Desking](#) on page 1117
- [Applications](#) on page 1118
- [Programming Appearance Buttons](#) on page 1118

---

## Appearance Button Features

Appearance functions are only supported on Avaya phones which have programmable buttons and also support multiple calls. Appearance functions are also only supported on those buttons that have suitable adjacent indicator lamps or a display area. Appearance buttons are not supported across a multi-site network.

**Related links**

- [Appearance Button Operation](#) on page 1079



## Call Appearance Buttons

Call appearance buttons are used to display alerts for incoming calls directed to a user's extension number or to a hunt group of which they are a member. Call appearance buttons are also used to make outgoing calls.

By having several call appearance buttons, a user is able to be alerted about several calls, select which call to answer, switch between calls and take other actions.

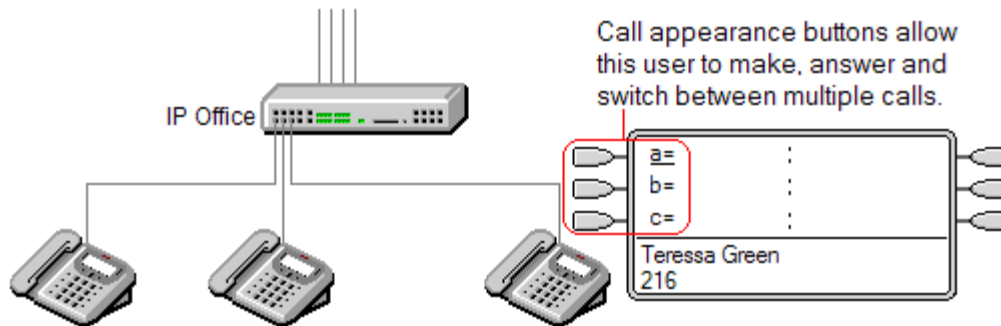

When all the user's call appearance buttons are in use or alerting, any further calls to their extension number receive busy treatment. Instead of busy tone, the user's forward on busy is used if enabled or otherwise voicemail if available.

Call appearance buttons are the primary feature of key and lamp operation. None of the other appearance button features can be used until a user has some call appearance button programmed[1].

There are also additional requirements to programming call appearance buttons:

Call appearance buttons must be the first button programmed for the user.

Programming a single call appearance button for a user is not supported. The normal default is 3 call appearances per user except on phones where only two physical buttons are available.

[1] For Release 4.2+, T3 phones support the use of Line Appearance buttons. These can be programmed against buttons on T3 phones without requiring call appearance buttons. See T3 Phone Line Appearances.

### Related links

[Appearance Button Operation](#) on page 1079

[Call Appearance Example 1](#) on page 1081

[Call Appearance Example 2](#) on page 1082

[How are Call Appearance Buttons Treated?](#) on page 1083

[Call Appearance Button Indication](#) on page 1084

## Call Appearance Example 1

In this example, the user has multiple call appearance buttons.

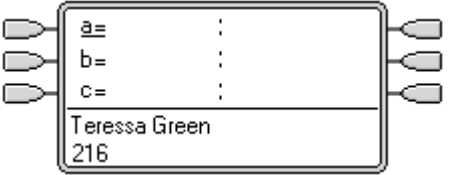
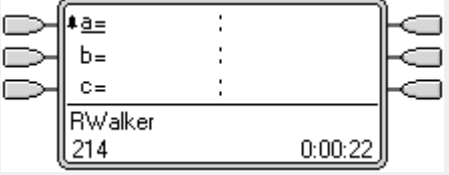
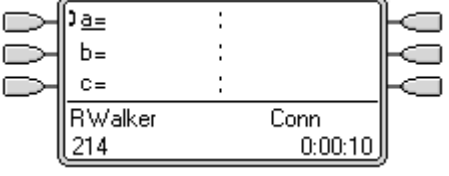
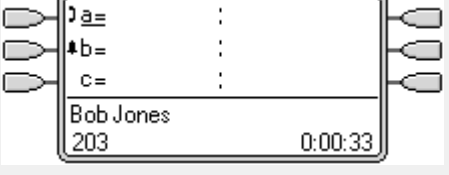
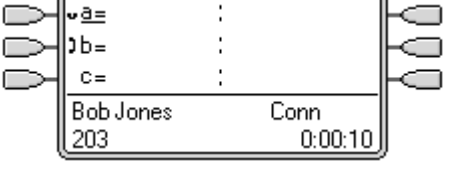
	<p><b>Phone Idle</b> The phone is currently idle.</p>
	<p><b>First Call Alerts</b> A call arrives. It alerts against the first available call appearance button. Pressing that button will answer the call.</p>
	<p><b>Call Answered</b> The call is now connected.</p>
	<p><b>Second Call Alerts</b> A second call arrives whilst the first is still connected. It alerts against the next available call appearance button. As the user has a call in progress, the alert gives just a single ring and briefly display details of the caller.</p>
	<p><b>Pressing the Second Call Appearance</b> Pressing the second call appearance button will hold the first call and answer the second.</p>

**Related links**

[Call Appearance Buttons](#) on page 1081

## Call Appearance Example 2

In this example, the user will use their call appearances to make two calls and start a conference between those calls.

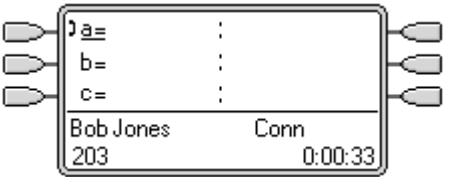
	<p><b>Initial Call</b> The user has a call in progress, shown on their first call appearance button. It is decided to conference another user into the call.</p>
-------------------------------------------------------------------------------------	------------------------------------------------------------------------------------------------------------------------------------------------------------------

*Table continues...*

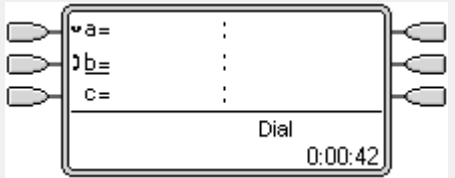
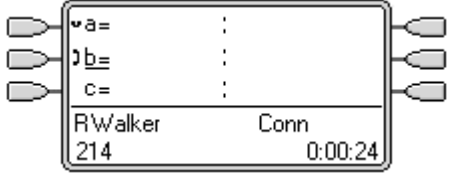
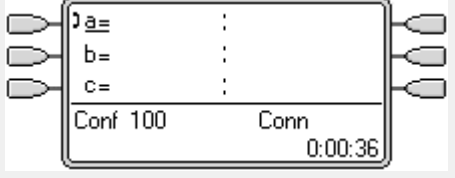
	<p><b>Make Conference Enquiry</b> Pressing the <b>CONFERENCE</b> button on the users phone automatically places the current call on hold and takes the phone off hook on the next available call appearance.</p>
	<p><b>Enquiry in Progress</b> The other extension has been dialed and invited to join a conference call. The user presses the <b>CONFERENCE</b> button on their phone again.</p>
	<p><b>Conference Starts</b> The conference call has started. The separate call appearances have collapsed to a single appearance that represents the conference.</p>

### Related links

[Call Appearance Buttons](#) on page 1081

## How are Call Appearance Buttons Treated?

### For incoming calls

**Call Waiting** settings are ignored except for hunt group call waiting where the call waiting tone is replaced by an alert on a call appearance button if available.

**Follow Me, Forward Unconditional** and **Forward Hunt Group Calls** are used when set.

If **Do Not Disturb** is set, only calls from numbers in the user's Do Not Disturb Exception list will alert if a call appearance is available.

### Busy status

**For calls direct to the user's extension number** The user is busy when all their available call appearances are in use. Instead of busy tone, the user's forward on busy is used if enabled or otherwise voicemail if available.

**For calls to a hunt group of which the user is a member** The user is busy to further hunt group calls when they have any appearance button in use on their phone. The only exception is calls to a collective hunt group with call waiting.

In both cases above, even when busy, the user may still receive alerts on other appearance buttons.

### For outgoing calls

Outgoing calls are treated exactly the same as calls made by non-appearance button users.

External Calls made on a call appearance, which route out on a line for which the user also has a line appearance, will remain on the call appearance. The line appearance will indicate 'in use elsewhere'.

**For call appearance buttons matched by a bridged appearance button**

If the bridged appearance is used to make or answer calls, the state of the call appearance will match that of the bridged appearance.

If the call is put on hold by the bridged appearance user, the call appearance will show 'on hold elsewhere'.

**Other**

**Held/Parked Call Timeout** If the user has parked a call, the parked call timer only starts running when the user is idle rather than on another call.

Incoming calls routed directly to the user as the incoming call routes destination on a line for which the user also has a line appearance, will only alert on the line appearance. These calls do not follow any forwarding set but can be covered.

**Related links**



[Call Appearance Buttons](#) on page 1081

## Call Appearance Button Indication















On phones with a text display area next to the button, by default **a=**, **b=** and so on is displayed. This can be replaced by another label if required.

When the user is not connected to a call, the button indicated as selected is the button that will be used if the user goes off hook without pressing an appearance button. When a user is connected to a call, that call is the selected button.

The following table shows how the different states of call appearance buttons (alerting, held, etc) are indicated. This is a general table, not all phone button types are covered. The ring that accompanies the visual indication can be delayed or switched off. See Ring Delay.

Icon Button	Dual LED Button	Call Appearance Button State
CA1	 Red off, Green off.	<b>Idle</b> The call appearance is not in use and is not currently selected.
CA1	 Red on, Green off.	<b>Idle + Selected</b> The call appearance is not in use but is the current selected button that will be used if the user goes off hook.

*Table continues...*

 <p>Flashing icon.</p>	 <p>Red off, Green steady flash.</p>	<p><b>Alerting</b> The matching call appearance is alerting for an incoming call. This is accompanied by ringing. If the user is already on a call, only a single ring is given.</p>
 <p>Flashing icon.</p>	 <p>Red on, Green steady flash.</p>	<p><b>Alerting + Selected</b> As above but Ringing Line Preference has made this the user's current selected button.</p>
 <p></p>	 <p>Red on, Green on.</p>	<p><b>In Use Here</b> The user has a call connected on the call appearance or is dialing.</p>
 <p></p>	 <p>Red off, Green on.</p>	<p><b>In Use Elsewhere</b> The call appearance button is in use on a bridged appearance.</p>
 <p></p>	 <p>Red off, Green fast flash.</p>	<p><b>On Hold Here</b> The call has been put on hold by this user.</p>
 <p></p>	 <p>Red fast flash, Green fast flash</p>	<p><b>On Hold Pending Transfer</b> Applies to 1400, 1600, 9500 and 9600 Series phones in Release 8.1 and higher.</p>
 <p></p>	 <p>Red off, Green intermittent flash.</p>	<p><b>On Hold Elsewhere</b> A call on a bridged appearance button matched to the call appearance has been put on hold. Calls on a call appearance that are put on hold by another user will continue to show connected lamp status, though the phone display will indicate a held call.</p>
 <p>Icon flashes off.</p>	 <p>Red off, Green broken flash.</p>	<p><b>Inaccessible</b> The button pressed is not accessible. The call is still dialing, ringing or cannot be bridged into.</p>

### Related links

[Call Appearance Buttons](#) on page 1081

## Bridged Appearance Buttons

A bridged appearance button shows the state of one of another user's call appearance buttons. It can be used to answer or join calls on that user's call appearance button. It can also be used to make a call that the call appearance user can then join or retrieve from hold.

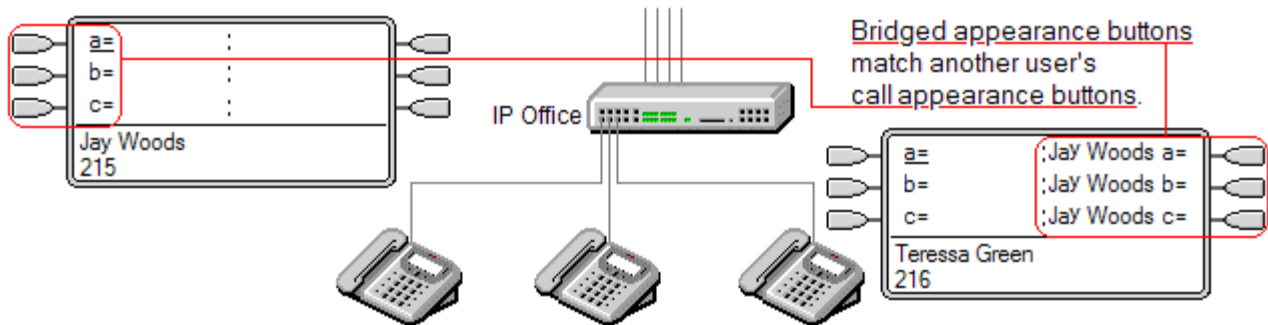

When the user's call appearance button alerts, any associated bridged appearance buttons on other user's phones also alert. The bridged appearance buttons can be used to answer the call on the call appearance button user's behalf.

When the call appearance button user answers or makes a call, any associated bridged appearance buttons on other users' phones show the status of the call, ie. active, on hold, etc. The bridged appearance button can be used to retrieve the call if on hold or to join the call if active (subject to intrusion permissions).

**Note** Bridged appearance buttons are different from the action of bridging into a call (joining a call). See [Joining Other Calls \(Bridging\)](#).

Bridged appearance buttons are not supported between users on different systems in a multi-site network.

### Related links

- [Appearance Button Operation](#) on page 1079
- [Bridged Appearance Example 1](#) on page 1086
- [Bridged Appearance Example 2](#) on page 1087
- [Bridged Appearance Example 3](#) on page 1088
- [How are Bridged Appearances Treated?](#) on page 1089
- [Bridged Appearance Button Indication](#) on page 1089

## Bridged Appearance Example 1

In this example, one user is able to see the status of the other user's call appearances, and when necessary answer calls for the other user. Both users have **Ringling Line Preference** and **Auto Hold** on.

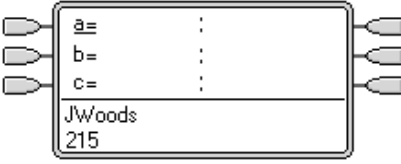
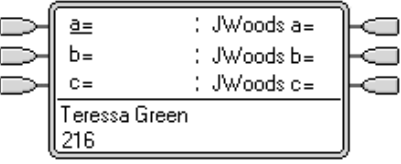
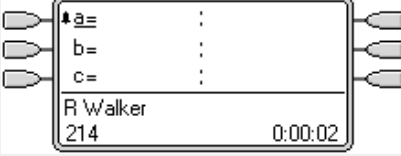
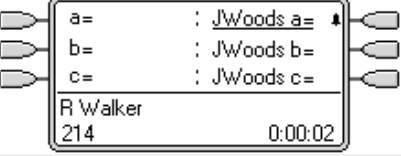
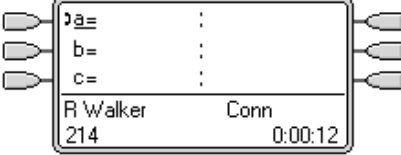
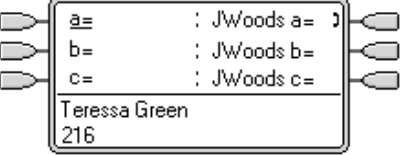
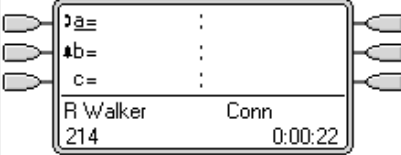
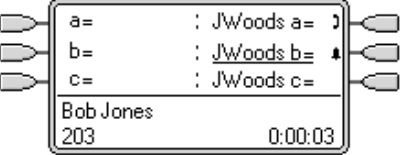
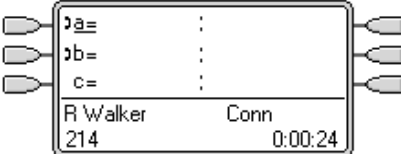
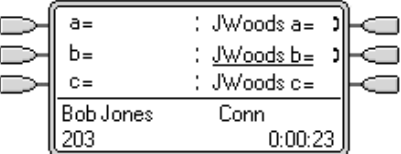
<p><b>Call Appearance User</b></p> 	<p><b>Bridged Appearance User</b></p> 	<p><b>Both Phone Idle</b> Our user has bridged appearance buttons that match a colleague's call appearances buttons.</p>
		<p><b>First Call</b> The colleague has a call alerting on their first call appearance button. It also alerts on our user's first bridged call appearance button.</p>
		<p><b>Call Answered</b> The colleague has answered the call. The bridged appearance indicates 'in use elsewhere'.</p>
		<p><b>Second Call</b> Another call alerts at the colleagues phone and again is mirrored on our user's second bridged call appearance button.</p>
		<p><b>Call Answered</b> Our user has gone off hook and answered the incoming call alerting on the bridged call appearance.</p>

**Related links**

[Bridged Appearance Buttons](#) on page 1086

## Bridged Appearance Example 2

In this example, the bridged appearance user makes a call on behalf of the call appearance user. Once the call is connected, they put it on hold. The call appearance user is able to take the call off hold using their call appearance button. Both users have **Ring Line Preference** and **Auto Hold** on.

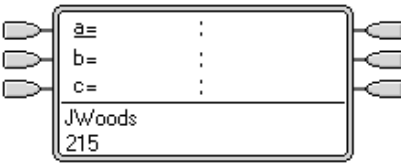
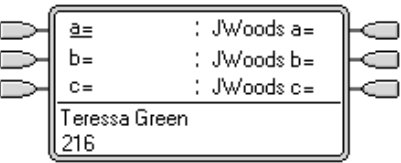
<p><b>Call Appearance User</b></p> 	<p><b>Bridge Appearance User</b></p> 	<p><b>Both Phones Idle</b> Our user has bridged appearance buttons that match a colleague's call appearances buttons.</p>
------------------------------------------------------------------------------------------------------------------------	---------------------------------------------------------------------------------------------------------------------------	---------------------------------------------------------------------------------------------------------------------------

*Table continues...*

		<p><b>Bridged User Makes Call</b> Our user has pressed a bridged appearance and made a call on it. The matching call appearance shows 'in use elsewhere'.</p>
		<p><b>Call Put on Hold</b> Having made the call, the bridged user puts it on hold. The matching call appearance indicates 'on hold elsewhere'.</p>
		<p><b>Call Taken Off Hold</b> By pressing the call appearance, the first user has answered the held call. The bridged appearance user returns to idle.</p>

**Related links**

[Bridged Appearance Buttons](#) on page 1086

### Bridged Appearance Example 3

In this example, a call is passed from the call appearance user to the bridged appearance user. Both users have **Ringing Line Preference** and **Auto Hold** on.

<p><b>Bridged Appearance User</b></p>	<p><b>Call on Colleague's Phone</b> The call appearance user has answered a call on one of their call appearances. The bridged appearance user's matching bridged appearance shows 'in use elsewhere'.</p>
	<p><b>Call Held by Colleague</b> The call appearance user has put the call on hold and called the bridged appearance user. The first bridged call appearance shows a call 'on hold elsewhere' whilst the second matches the call between users.</p>
	<p><b>Enquiry Call Between Colleagues</b> By going off hook, the bridged appearance user has answered the call from the call appearance user. They are asked to pickup the call on the colleagues first call appearance.</p>

*Table continues...*

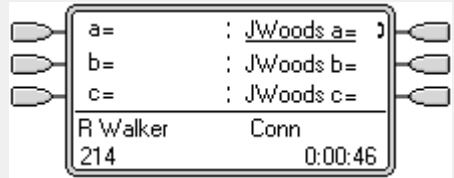

	<p><b>Call Taken Off Hold</b> Pressing the first bridged appearance button takes that call off hold and connects it to the bridged appearance user.</p> <p>In this example, <b>Auto Hold</b> is not set for the system, so pressing the bridged appearance button disconnected the call from the colleague.</p> <p>If <b>Auto Hold</b> had been set, the colleague's call would have been put on hold until they hung up.</p>
-----------------------------------------------------------------------------------	-------------------------------------------------------------------------------------------------------------------------------------------------------------------------------------------------------------------------------------------------------------------------------------------------------------------------------------------------------------------------------------------------------------------------------

### Related links

[Bridged Appearance Buttons](#) on page 1086

---

## How are Bridged Appearances Treated?

Bridged appearance buttons operate in parallel with their matching call appearance button.

**Whose user settings control the call?** Until answered on a bridged appearance button, calls alerting on a bridged appearance button follow the settings of the user or hunt group to which the call was originally directed.

If the call appearance is in use, any matching bridged appearance will indicate the same.

If a bridged appearance is in use, the call appearance it matches will indicate the same.

The bridge appearance will only alert if the call appearance is alerting. For example, direct intercom and paging call to the call appearance will show on the bridged appearance but will not give any audible alert.

If the bridged appearance user put the call on hold, the call appearance indicates 'on hold elsewhere'.

Bridged appearances to a user who has logged out, or has logged into a phone without appearance buttons will not operate.

If the bridged appearance user has 'do not disturb' (DND) enabled, the bridge appearance button icon or lamps operates but alerting and ringing line preference selection is not applied unless the caller is in the user's DND exception list.

Bridged appearance buttons are not supported between users on different systems in a multi-site network.

### Related links









[Bridged Appearance Buttons](#) on page 1086

---

## Bridged Appearance Button Indication

On phones with a text display area next to the button, the name of the bridged user and the label from the bridged user's call appearance key are displayed.

The following table shows how the different states of bridged appearance buttons (alerting, held, etc) are indicated. This is a general table, not all phone button types are covered. The ring that accompanies the visual indication can be delayed or switched off. See Ring Delay.

Icon Button	Dual LED Button	Bridge Appearance Button State
JWoods CA1	 Red off, Green off.	<b>Idle</b> The bridged appearance is not in use.
#JWoods CA1 Flashing icon.	 Red off, Green steady flash.	<b>Alerting</b> The matching call appearance is alerting for an incoming call. This is accompanied by ringing. If the user is already on a call, only a single ring is given.
#JWoods CA1 Flashing icon.	 Red on, Green steady flash.	<b>Alerting + Selected</b> As above but Ringing Line Preference has made this the user's current selected button.
JWoods CA1	 Red off, Green on.	<b>In Use Elsewhere</b> The matching call appearance button is in use.
JWoods CA1	 Red on, Green on.	<b>In Use Here</b> The user has made a call or answered a call on the bridged appearance, or bridged into it.
vJWoods CA1	 Red off, Green fast flash.	<b>On Hold Here</b> The call has been put on hold by this user.
vJWoods CA1	 Red off, Green intermittent flash.	<b>On Hold Elsewhere</b> The call on that call appearance has been put on hold by another user.
JWoods CA1 Icon flashes off.	 Red off, Green broken flash.	<b>Inaccessible</b> The button pressed is not usable. The call is still dialing, ringing or cannot be bridged into.

**Related links**

[Bridged Appearance Buttons](#) on page 1086

# Call Coverage Buttons

Call coverage allows a user to be alerted when another user has an unanswered call.

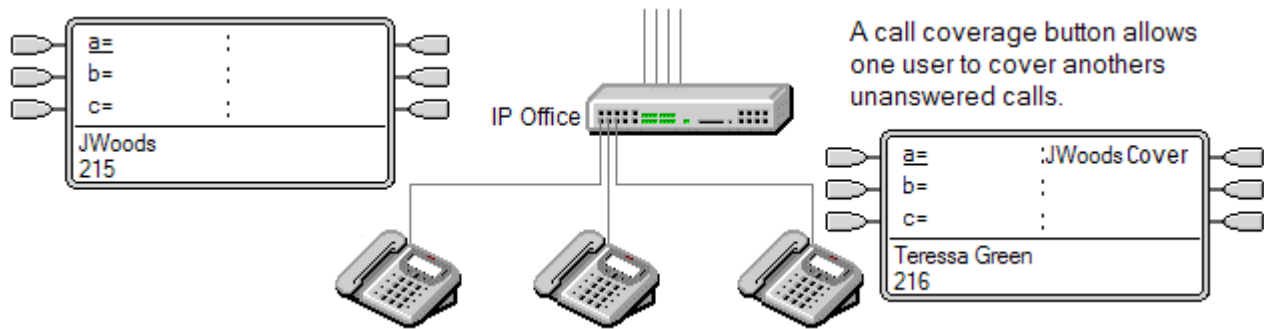

The user being covered does not necessarily have to be a key and lamp user or have any programmed appearance buttons. Their Individual Coverage Time setting (default 10 seconds) sets how long calls will alert at their extension before also alerting on call coverage buttons set to that user.

The user doing the covering must have appearance buttons including a call coverage appearance button programmed to the covered users name.

Call coverage appearance buttons are not supported between users on different systems in a multi-site network.

## Related links

- [Appearance Button Operation](#) on page 1079
- [Call Coverage Example 1](#) on page 1091
- [Call Coverage Example 2](#) on page 1092
- [How is Call Coverage Treated?](#) on page 1093
- [Call Coverage Button Indication](#) on page 1094

## Call Coverage Example 1

In this example, the covering user is able to answer their colleagues call when it rings unanswered. Both users have **Ringing Line Preference** and **Auto Hold** on.

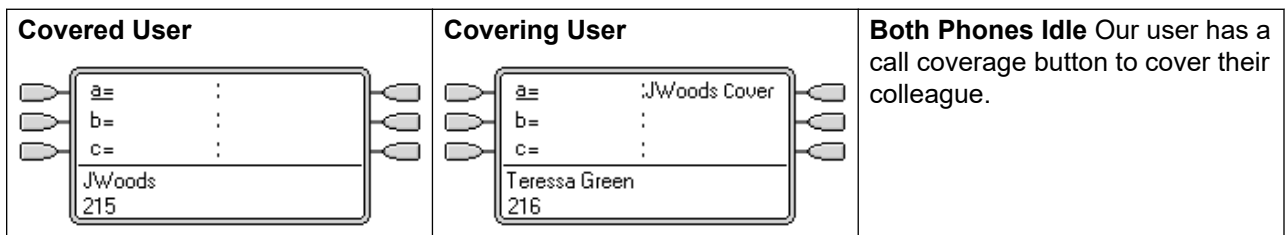

*Table continues...*

		<p><b>Call to Covered User</b> A call arrives for the covered user.</p>
		<p><b>Call Alerts to Coverage</b> After ringing for the covered user's Individual Coverage Time, the call also begins alerting on the call coverage button.</p>
		<p><b>Covering User Answers</b> By going off hook or pressing the alerting button, the covering user has answered the call.</p>

**Related links**

[Call Coverage Buttons](#) on page 1091

## Call Coverage Example 2

In this example, the covered user has calls on all their available call appearances. Both users have **Ringing Line Preference** and **Auto Hold** on.

<p><b>Covered User</b></p>	<p><b>Covering User</b></p>	<p><b>Calls in Progress</b> The covered user already has a number of calls in progress on all their call appearance keys.</p>
		<p><b>Call Alerts to Coverage</b> The covered user is treated as busy, so their next call goes immediately to call coverage.</p>
		<p><b>Covering User Answers</b> The covering user has answered the call.</p>

**Related links**

[Call Coverage Buttons](#) on page 1091

---

## How is Call Coverage Treated?

### Whose user settings control the call ?

Until answered, calls alerting on a call coverage button follow the settings of the user to which the call was originally directed.

Once answered, the call follows the user settings of the user who answered it.

### Coverage is applied to :

- Internal calls dialed to the covered user's extension number.
- External calls routed to the covered user by a incoming call route.
- Calls forwarded internally by the covered user or on follow me from the covered user.

### Coverage is not applied to :

- Hunt group calls to a hunt group of which the covered user is a member.
- Calls forwarded to the covered user using forward or follow me functions.
- Calls alerting on the covered user's bridged appearance and call coverage buttons.
- Coverage is only applied to calls alerting on a line appearance if the call was also routed to that user by an incoming call route.
- Page and intercom calls.
- Parked, transferred and held calls ringing back to the user.
- Automatic callback calls set by the covered user.
- Voicemail ringback calls.
- Call coverage appearance buttons are not supported between users on different systems in a multi-site network.

### Coverage is applied :

- If the covered user's phone is available, call coverage is applied only after the covered user's Individual Coverage Time has expired.
- If the covered user's phone is busy, call coverage is applied immediately.
- If the covered user is using follow me or forward all to an internal number to divert their calls, call coverage is still applied.
- If the covered user has 'do not disturb' on, call coverage is applied immediately except for calls from numbers in the covered user's do not disturb exceptions list.

### Other items :

If the call is not answered after the covered user's **No Answer Time** it will go to the covered user's voicemail if available or follow their forward on no answer settings.

If the covered user has several alerting calls, the call answered by the call coverage button is the covered user's longest ringing call.

Calls will not alert at a covering user who has 'do not disturb' enabled, except when the calling number is in the covering user's do not disturb exception list.

**Related links**





[Call Coverage Buttons](#) on page 1091

## Call Coverage Button Indication

On phones with a text display area next to the button, the name of the covered user is displayed followed by the word **Cover**.

When the user is not connected to a call, the button indicated as selected is the button that will be used if the user goes off hook without pressing an appearance button. When a user is connected to a call, that call is the selected button.

The following table shows how the different states of call coverage appearance buttons (alerting, held, etc) are indicated. This is a general table, not all phone button types are covered. The ring that accompanies the visual indication can be delayed or switched off. See Ring Delay.

Icon Button	Dual LED Button	Call Coverage Button State
JWoods Cover	 Red off, Green off.	<b>Idle</b> The button is not in use.
#JWoods Cover Flashing icon.	 Red off, Green steady flash.	<b>Alerting</b> The call coverage is alerting for an unanswered call at the covered user's phone. This is accompanied by ringing. If the user is already on a call, only a single ring is given.
#JWoods Cover Flashing icon.	 Red on, Green steady flash.	<b>Alerting + Selected</b> As above but Ringing Line Preference has made this the user's current selected button.
JJWoods Cover	 Red on, Green on.	<b>In Use Here</b> The user has answered the call requiring coverage.
WJWoods Cover	 Red off, Green fast flash.	<b>On Hold Here</b> The covered call has been put on hold by the call coverage button user.

**Related links**

[Call Coverage Buttons](#) on page 1091

## Line Appearance Buttons

Line appearance buttons allow specific individual line to be used when making calls or answered when they have an incoming call. It also allows users to bridge into calls on a particular line.

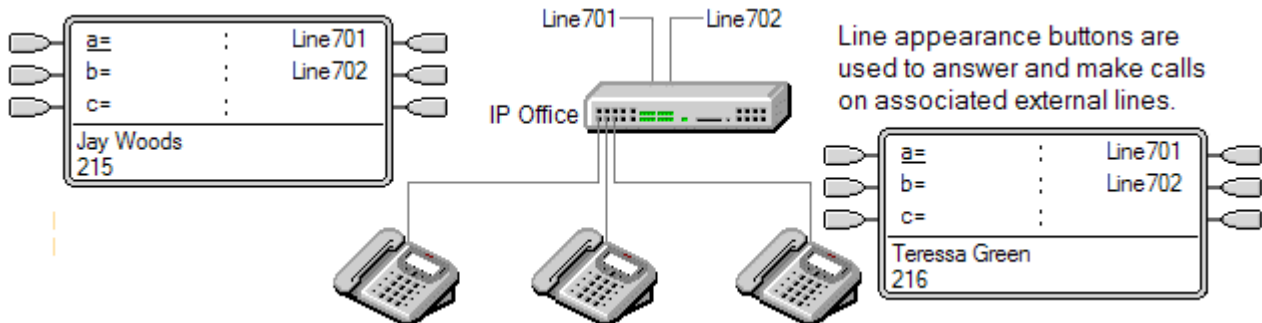

Incoming call routing is still used to determine the destination of all incoming calls. Line appearance buttons allow a call on a specific line to alert the button user as well as the intended call destination. When these are one and the same, the call will only alert on the line appearance but can still receive call coverage.

When alerting on suitable phones, details of the caller and the call destination are shown during the initial alert.

Individual line appearance ID numbers to be assigned to selected lines on a system. Line appearance buttons are only supported for analog, E1 PRI, T1, T1 PRI, and BRI PSTN trunks; they are not supported for other trunks including E1R2, QSIG and IP trunks.

Line appearance buttons are not supported for lines on remote systems in a multi-site network.

**Using Line Appearances for Outgoing Calls** In order to use a line appearance to make outgoing calls, changes to the normal external dialing short codes are required. For full details see [Outgoing Line Programming](#).

**Private Lines** Special behaviour is applied to calls where the user has both a line appearance for the line involved and is also the Incoming Call Route destination of that call. Such calls will alert only on the Line Appearance button and not on any other buttons. These calls will also not follow any forwarding.

**T3 Phone Line Appearances** Line appearances are supported on T3 and T3 IP phones, see [T3 Phone Line Appearances](#).

### Related links

- [Appearance Button Operation](#) on page 1079
- [Line Appearance Example 1](#) on page 1096
- [Line Appearance Example 2](#) on page 1096
- [How are Line Appearances Treated?](#) on page 1097
- [Line Appearance Button Indication](#) on page 1098
- [T3 Phone Line Appearances](#) on page 1099

## Line Appearance Example 1

In this example, the user is able to answer a call alerting on a particular line.

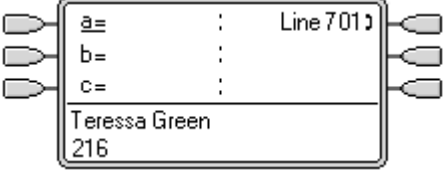
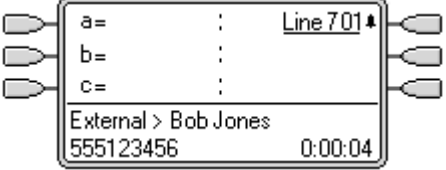
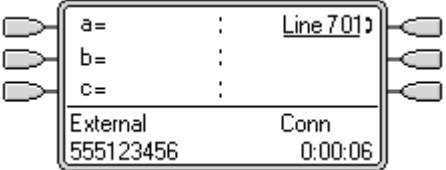
	<p><b>Line Goes Active</b> A call is active on the line with line ID number 601. This is indicated as 'in use elsewhere'.</p> <p>For an incoming call, the line will show active but will not alert until call routing has been determined. On analog ICLID lines, alerting is delayed until the ICLID that might be used to do the call routing has been received.</p>
	<p><b>Line Appearance Alerting</b> The routing of the call has been complete and it is ringing against its destination. On our user's phone the line appearance also alerts and ringing line preference has made it the current selected button.</p>
	<p><b>Answer Call</b> By going off hook or pressing the line appearance, our user has answered the call on that line.</p>

### Related links

[Line Appearance Buttons](#) on page 1095

## Line Appearance Example 2

In this example, two users exchange a call using line appearance buttons set to the same line. Note that this requires that the user who first answers the call to have **Cannot be Intruded** off. Both users have **Ringing Line Preference** and **Auto Hold** on.

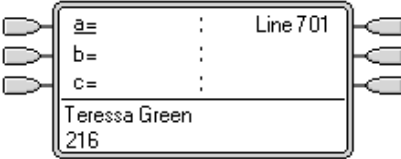
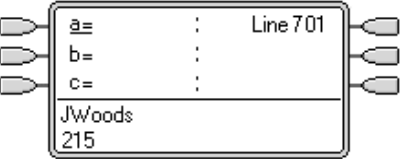
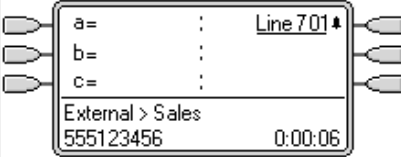
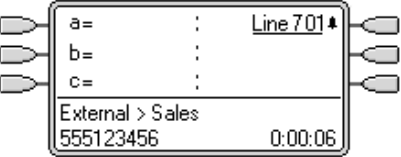
		<p><b>Idle</b> The two users have line appearances for the same line.</p>
		<p><b>Call Alerts</b> A call arrives. Either user can answer it by pressing the alerting line appearance</p>

*Table continues...*



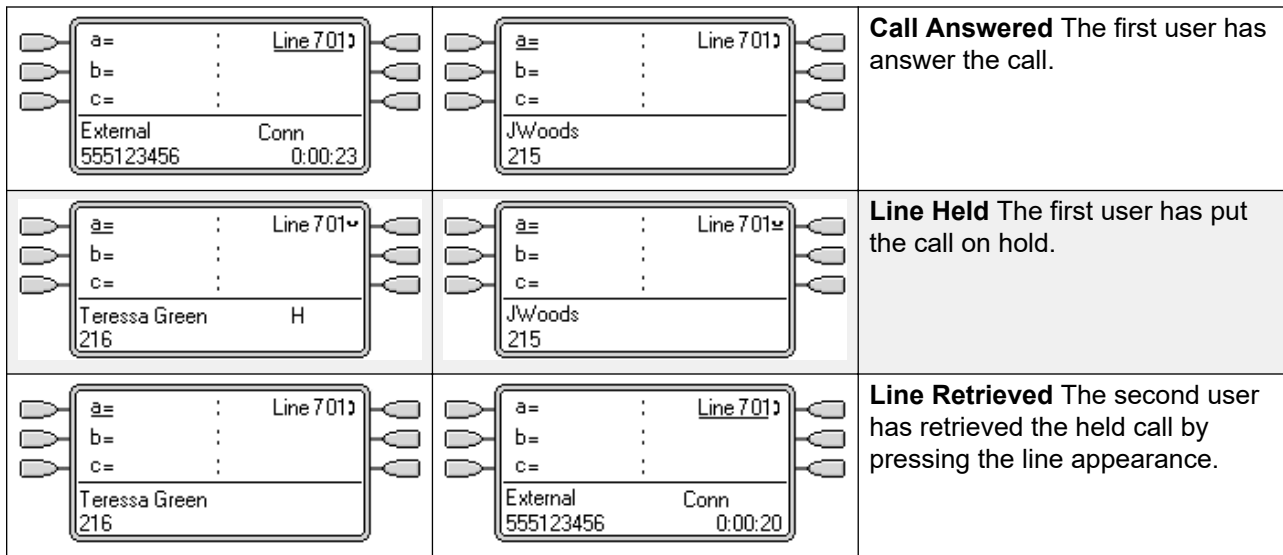

### Related links

[Line Appearance Buttons](#) on page 1095

## How are Line Appearances Treated?

### Incoming Calls

**Until answered using a line appearance button, incoming calls alerting on a line appearance, follow the settings of the incoming call route's destination group or user. They do not follow the settings of any line appearance user.**

If an incoming call's destination is voicemail, or once the incoming call has passed from its destination to voicemail, it cannot be answered or bridged into using a line appearance button.

If the line appearance user is also the incoming call route destination for the call, the call will alert on their line appearance only. In this case:

- It will alert on the line appearance even if all call appearances are in use.
- The call will not follow any of the user's forwarding settings .
- The call will receive call coverage from other user's with call coverage buttons set to the line appearance user.
- The ring delay used is that of the first free call appearance.

For analog lines set to ICLID, any line appearances show active while the system waits for ICLID information. During this time the line has not been routed and cannot be answered using a line appearance button.

Calls alerting on a line appearance can also alert on a call coverage appearance on the same phone. If Ringing Line Preference is set, the current selected button will change from the line appearance to the call coverage appearance.

If the line appearance user has do not disturb (DND) enabled, the line appearance button icon or lamps will still operate but alerting and ringing line preference selection are not applied unless the caller is in their DND exception list.

**Outgoing Calls**

In order to be used for making outgoing calls, some additional system programming may be required. See [Outgoing Line Programming](#).

Calls made on a call appearance, which are routed out on a line for which the user also has a line appearance, will remain on the call appearance. The line appearance will indicate 'in use elsewhere'.

**Additional Notes**

Calls alerting on a line appearance do not receive call coverage or go to a users voicemail unless the user was the call's original incoming call route destination.

If a call indicated by a line appearance is parked, it cannot be joined or unparked by using another line appearance.

Where a line appearance button is used to answer a call for which automatic call recording is invoked, the recording will go to the automatic recording mailbox setting of the original call destination.

Line appearance buttons are not supported for lines on remote systems in a multi-site network.

**Related links**



[Line Appearance Buttons](#) on page 1095

**Line Appearance Button Indication**







On phones with a text display area next to the button, the label **Line** and the line number are displayed.

When the user is not connected to a call, the button indicated as selected is the button that will be used if the user goes off hook without pressing an appearance button. When a user is connected to a call, that call is the selected button.

The following table shows how the different states of line appearance buttons (alerting, held, etc) are indicated. This is a general table, not all phone button types are covered. The ring that accompanies the visual indication can be delayed or switched off. See [Ring Delay](#).

Icon Button	Dual LED Button	Line Appearance Button State
Line 601	 All off.	<b>Idle</b> The associated line is not in use.
Line 601		<b>Idle + Selected</b> The associated line is not in use but the button is the user currently selected button.

*Table continues...*

▲Line 601 Flashing icon.	 Red off, Green steady flash.	<b>Alerting</b> The line is ringing at its incoming call route destination. This is accompanied by ringing. If the user is already on a call, only a single ring is given.
▲Line 601 Flashing icon.	 Red on, Green steady flash.	<b>Alerting + Selected</b> As above but Ringing Line Preference has made this the user's current selected button.
▷Line 601	 Red off, Green on.	<b>In Use Elsewhere</b> The line is in use.
▷Line 601	 Red on, Green on.	<b>In Use Here</b> The user has answered the line, made a call on it or bridged into the call on the line.
◁Line 601	 Red off, Green fast flash.	<b>On Hold Here</b> The call on the line has been put on hold by this user.
◁Line 601	 Red off, Green intermittent flash.	<b>On Hold Elsewhere</b> The call on the line has been put on hold by another appearance button user.
◀Line 601 Icon flashes off.	 Red off, Green broken flash.	<b>Inaccessible</b> The button pressed is not accessible. The call is still dialing, ringing, routing or cannot be bridged into.

### Related links

[Line Appearance Buttons](#) on page 1095

## T3 Phone Line Appearances

### \* Note:

IP Office R11 does not support T3 and T3 IP Phones.

Release 4.2+: Line appearances are supported on T3 and T3 IP phones. As these phones do not support call appearance, bridge appearance or call coverage appearance buttons the user can be programmed with just line appearance buttons.

Soft Key	LED Key	Line Appearance Button State
<b>L601</b>	Off	<b>Idle</b> The associated line is not in use.
<b>✓ 601</b>	Off	<b>Idle + Selected</b> The associated line is not in use but the button is the user currently selected button.

*Table continues...*

L601 alternating with bell symbol.	Fast flashing	<b>Alerting</b> The line is ringing at it incoming call route destination. This is accompanied by ringing. If the user is already on a call, only a single ring is given.
L601 alternating with bell symbol.	Fast flashing	<b>Alerting + Selected</b> As above but Ringing Line Preference has made this the user's current selected button.
L601	On	<b>In Use Elsewhere</b> The line is in use.
✓ 601	On	<b>In Use Here</b> The user has answered the line, made a call on it or bridged into the call on the line.
L601 Slow flash	Slow flash	<b>On Hold Here</b> The call on the line has been put on hold by this user.
L601 Slow flash	Slow flash	<b>On Hold Elsewhere</b> The call on the line has been put on hold by another appearance button user.
-601	Off	<b>Inaccessible</b> The button pressed is not accessible. The call is still dialing, ringing, routing or cannot be bridged into. A single tone is also given.

**Notes**

**Hot Desking** The following applies to appearance button programmed for a user on a system with T3 phones.

- **From a T3 Phone** If a T3 user with programmed line appearances but no programmed call appearances hot desks onto a phone type that requires call appearances, the phone will not operate correctly. This configuration is not supported by Avaya.
- **To a T3 Phone** If appearance buttons other than line appearance are programmed for a user, when that user in on a T3 phone those other appearance buttons will be treated as blank. Depending on the button and type of T3 phone the button may assume its default T3 phone function. See T3 Compact, T3 Classic and T3 Comfort.

**Call Waiting** Line appearances will ignore the T3 phones user selected call waiting setting. So with a call connected and call waiting off, calls can still alert on line appearances.

**Multiple Calls** T3 phones are limited to a maximum of 6 associated calls at any time, including calls connected, on hold and alerting.

**Delayed Ringing** The only Ring Delay options supported are Immediate or No Ring. Any other delayed

**Preference** Idle line preference is always used, however T3 phones will never default to using a line appearance for an outbound call.

**Joining/Bridging** Joining a call active on a line appearance is supported. This is subject to the intrusion settings of the users involved. The call then becomes a conference call.

### Related links

[Line Appearance Buttons](#) on page 1095

## Selected Button Indication

During appearance button usage, one of the user's appearance buttons may be indicated as the user's current selected button. This is the appearance button already in use, or if idle, the appearance button that will be used if the user goes off hook by lifting the handset.

On phones with a display area next to each button, the current selected button is indicated by either an \_ underscore of the button label, a \* star or a shaded background.

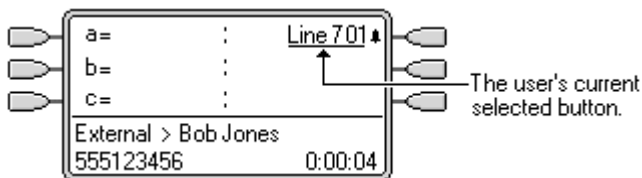

On phones with twin LED lamps, the current selected button is indicated by the red lamp being on



On Transtalk 9040 phones, the current selected button is indicated by a ◀ icon.

The system sets which appearance button is the current selected button using the following methods:

- **Idle Line Preference** This feature can be set on or off for each individual user, the default is on. When on, it sets the current selected button as the first available idle call/line appearance button. See [Idle Line Preference](#).
- **Ringing Line Preference** This feature can be set on or off for each individual user, the default is on. When on, it sets the current selected button as the button which has been alerting at the users phone for the longest. Ringing Line Preference overrides Idle Line Preference. See [Ringing Line Preference](#).
- **Delayed Ring Preference:** This setting is used in conjunction with ringing line preference and appearance buttons set to delayed or no ring. It sets whether ringing line preference should observe or ignore the delayed ring applied to the user's appearance buttons when determining which button should have current selected button status.
- **User Selection** The phone user can override both **Idle Line Preference** and **Ringing Line Preference** by pressing the appearance button they want to use or answer. That button will then remain the current selected button whilst active.

If the user currently has a call connected, pressing another appearance button will either hold or disconnect that call. The action is determined by the system's Auto Hold setting.

**Answer Pre-Select:** Normally when a user has multiple alerting calls, only the details of the call on current selected button are shown. Pressing any of the alerting buttons will answer the call on that button, going off-hook will answer the current selected button. Enabling the user telephony setting **Answer Pre-Select** allows the user to press any alerting button to make it the current selected button and displaying its call details without answering that call. To answer a call when the user has **Answer Pre-Select** enabled, the user must press the alerting button to display the call details and then either press the button again or go off-hook.

**Related links**

[Appearance Button Operation](#) on page 1079

## Idle Line Preference

Idle Line Preference determines the user's currently selected button as the first available idle call/line appearance button. Selected button indication is applied to that button and if the user goes off-hook, for example by lifting their handset, an outgoing call is started on that button.

**Idle Line Preference** is overridden by **Ringling Line Preference** if also on for the user.

By default **Idle Line Preference** is on for all users.

For appearance button users with **Idle Line Preference** off, going off-hook (lifting the handset or pressing **SPEAKER, HEADSET**, etc) will have no effect until an appearance button is pressed.

If all the available call/line appearance buttons are in use, no current selected button choice is made by **Idle Line Preference**. In this case, going off hook will have no effect.

**?Why Would I Use Just Idle Line Preference** In environments that are focused on making outgoing calls, for example telemarketing, incoming calls are infrequent and user's go off-hook expecting to make a call. Using **Idle Line Preference** without **Ringling Line Preference** ensures that the user doesn't inadvertently answer a call when expecting to make a call.

**Idle Line Preference Example 1**

In this example, only **Idle Line Preference** has been programmed for the user. **Ringling Line Preference** has not been programmed.

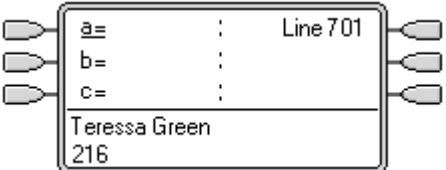
	<p><b>Phone Idle</b> The phone is idle. The current selected button determined by Idle Line Preference is the first available idle call appearance button. This is shown by the _ underscore of the button text.</p>
-------------------------------------------------------------------------------------	----------------------------------------------------------------------------------------------------------------------------------------------------------------------------------------------------------------------

*Table continues...*

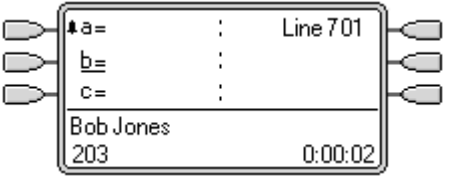
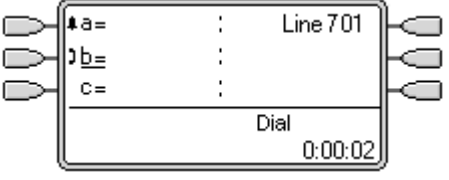
	<p><b>First Call to User</b> A call for the user arrives. It alerts on the first available call appearance button. Idle Line Preference has changed the current selected button to the next available idle call appearance.</p>
	<ol style="list-style-type: none"> <li><b>User Goes Off Hook</b> With the call still alerting, if the user goes off hook, it will be interpreted as making a call using the currently selected button, not as answering the alerting button.</li> <li>To answer the alerting call, the user should press the alerting button.</li> </ol>

Idle Line Preference Example 2

In this example, only **Idle Line Preference** has been programmed for the user. **Ringling Line Preference** has not been not programmed.

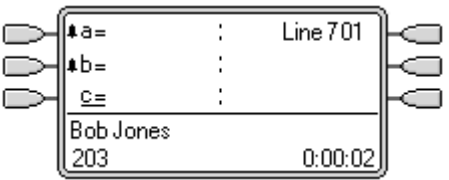
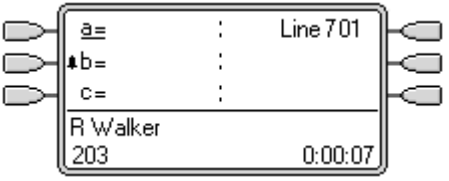
	<p><b>Two Calls Alerting</b> The users has two incoming calls alerting. Idle Line Preference has set the currently selected button to their third call appearance.</p>
	<p><b>First Caller Abandons</b> If the first incoming caller disconnects, the currently selected button changes to the first call appearance as this is now the first available idle call appearance button.</p>

Idle Line Preference Example 3

In this example, both **Idle Line Preference** and **Ringling Line Preference** are set for the user.

	<p><b>Phone Idle</b> The phone is idle and <b>Idle Line Preference</b> has assigned current selected button to the first call appearance.</p>
	<p><b>Call Alerting</b> A call has arrived and <b>Ringling Line Preference</b> keeps the current selected button at the first call appearance.</p>

Table continues...

	<p><b>Call Answered</b> With the call answered it retains current selected button status.</p>
	<p><b>Call Held</b> When the call is put on hold, <b>Idle Line Preference</b> assigns current selected button status to the next available call appearance button.</p>

#### Idle Line Preference Example 4

In this example, only **Idle Line Preference** has been programmed for the user. **Ringing Line Preference** has not been programmed.

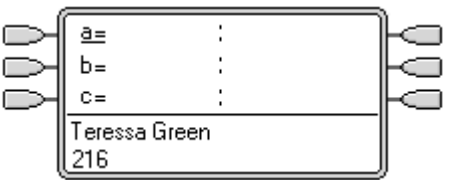
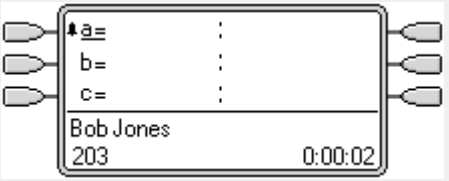
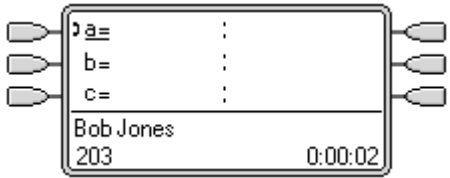
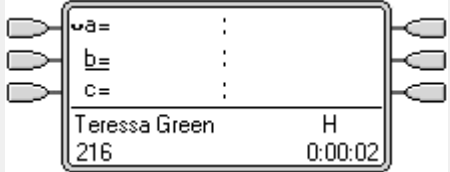
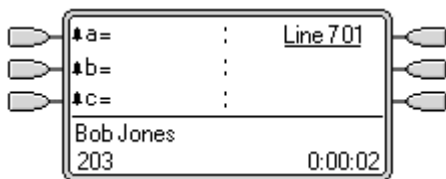

**All Call Appearances Alerting** In this case, all the users call appearance buttons are alerting incoming calls. Idle Line Preference has changed the currently selected button to the first available line appearance.

#### Related links

[Appearance Button Operation](#) on page 1079

## Ringing Line Preference

Ringing Line Preference determines the user's currently selected button as the button which has been alerting the longest. Selected button indication is applied to that button and if the user goes off-hook, for example by lifting their handset, the alerting call on that button is answered.

Ringing Line Preference includes calls alerting on call appearance, line appearance, bridged appearance and call coverage buttons.

**Ringing Line Preference** overrides **Idle Line Preference**.

By default **Ringing Line Preference** is on for all users.

**Ringing Line Preference Order** When a user's longest waiting call alerts on several of the user's appearance buttons and Ringing Line Preference is set for the user, the order used for current selected button assignment is;

Call appearance.



Bridged appearance.

Call coverage.

Line appearance.

**Example:** A user has a call to a covered user alerting initially on a line appearance button. Ringing Line Preference assigns current selected button status to the line appearance. When the same call also begins to alert on the call coverage appearance button, current selected button status switches to the call coverage appearance button.

**Ring Delay and Ringing Line Preference** Appearance buttons can be set to **Delayed Ring** or **No Ring**. These buttons still alert visually but do not give an audible ring or tone. Ringing line preference is still applied to alerting buttons even if set to **Delayed Ring** or **No Ring**.

**Delayed Ring Preference** For users with **Ringing Line Preference** selected, their **Delayed Ring Preference** setting sets whether ringing line preference is used or ignores buttons that are visually alerting but have **Delayed Ring** or **No Ring** set. The default is off, ie. ignore ring delay.

Ringing Line Preference Example 1

In this example, both **Ring Line Preference** and **Idle Line Preference** have been set for the user. They also have **Ringing Line Preference** on and **Auto Hold** is on. **Answer Pre-Select** is off.

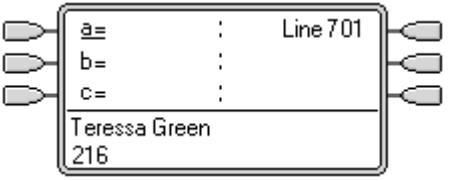
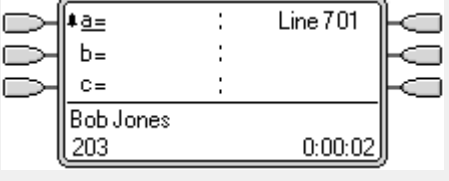
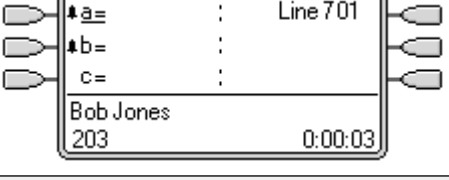
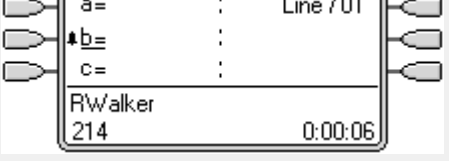
	<p><b>Phone Idle</b> The phone is idle. The current selected button has been determined by Idle Line Preference as the first available idle call appearance button. This is shown by the _ underscore next to that button.</p>
	<p><b>First Call Alerting</b> A call for the user arrives. It alerts on the first available call appearance button. Ringing Line Preference uses this as the currently selected button as it is the only alerting call.</p>
	<p><b>Second Call Alerting</b> Another call for the user arrives. It alerts on the next available call appearance button. As the first call has been alerting longer, under Ringing Line Preference it retains the currently select button status.</p>
	<p><b>The First Call Abandons</b> The first caller disconnects. Ringing Line Preference changes the currently selected button status to the second call appearance button.</p>

*Table continues...*

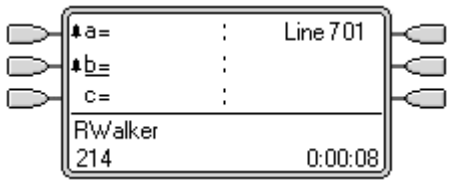
 <p>The diagram shows a call appearance button with three buttons labeled 'a=', 'b=', and 'c=' on the left. The display area shows 'Line 701' at the top, 'RWalker' in the middle, and '214' and '0:00:08' at the bottom.</p>	<p><b>Another Call Arrives</b> Another call arrives. It alerts as the first free call appearance button. However the call at the second call appearance has been alerting longer and so under Ringing Line Preference retain the currently selected button status.</p>
----------------------------------------------------------------------------------------------------------------------------------------------------------------------------------------------------------------------------------------------------------------------------------------------------------------	------------------------------------------------------------------------------------------------------------------------------------------------------------------------------------------------------------------------------------------------------------------------

### Ringing Line Preference Example 2

In this example, the user has both Ring Line Preference and Idle Line Preference programmed. They also have **Ringing Line Preference** on and **Auto Hold** is on. **Answer Pre-Select** is off.

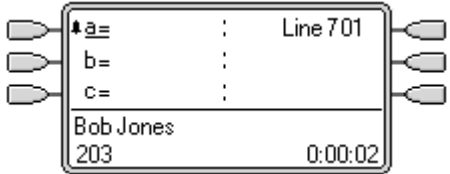
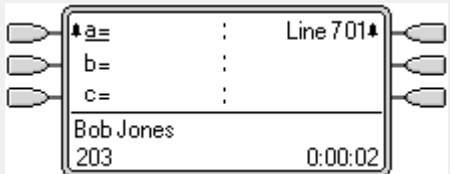
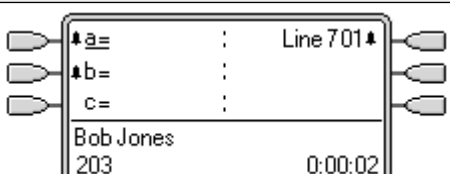
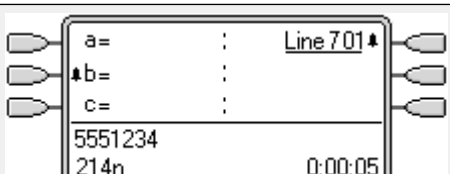
 <p>The diagram shows a call appearance button with three buttons labeled 'a=', 'b=', and 'c=' on the left. The display area shows 'Line 701' at the top, 'Bob Jones' in the middle, and '203' and '0:00:02' at the bottom.</p>	<p><b>First Call to User</b> A call for the user arrives. It alerts on the first available call appearance button. Ringing Line Preference uses this as the currently selected button as it is the only alerting call.</p>
 <p>The diagram shows a call appearance button with three buttons labeled 'a=', 'b=', and 'c=' on the left. The display area shows 'Line 601' at the top, 'Bob Jones' in the middle, and '203' and '0:00:02' at the bottom.</p>	<p><b>Call on Line 601</b> The user's Line Appearance is alerting due to an incoming call on the associated line. Details of the call and its destination are shown. Ringing Line Preference keeps the currently selected button status on the call appearance button as this has been alerting longest.</p>
 <p>The diagram shows a call appearance button with three buttons labeled 'a=', 'b=', and 'c=' on the left. The display area shows 'Line 701' at the top, 'Bob Jones' in the middle, and '203' and '0:00:02' at the bottom.</p>	<p><b>Second Call to User</b> A second call to the user arrives and alerts on the second call appearance button. Ringing Line Preference keeps the currently selected button status on the call appearance button as this has been alerting longest.</p>
 <p>The diagram shows a call appearance button with three buttons labeled 'a=', 'b=', and 'c=' on the left. The display area shows 'Line 701' at the top, '5551234' in the middle, and '214n' and '0:00:05' at the bottom.</p>	<p><b>The First Caller Abandons</b> The first call to the user disconnects. Ringing Line Preference passes the currently selected button status to the Line Appearance button as this has been alerting longest.</p>

### Related links

[Appearance Button Operation](#) on page 1079

## Answer Pre-Select

On some phones, only the details of the call alerting or connected on the current selected button are shown. The details of calls alerting on other buttons are not shown or only shown briefly when they are first presented and are then replaced again by the details of the call on the current selected button.

By default, pressing any of the other alerting buttons will answer the call on that button. Answer pre-select allows a user to press alerting buttons other than the current selected button without actually answering them. Instead the button pressed becomes the current selected button and its call details are displayed.

Note that using answer pre-select with a currently connected call will still either hold or end that call in accordance with the system's Auto Hold setting.

Answer Pre-Select Example 1

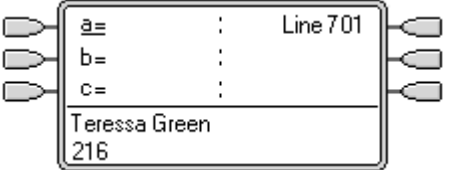
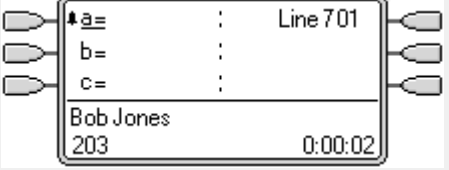
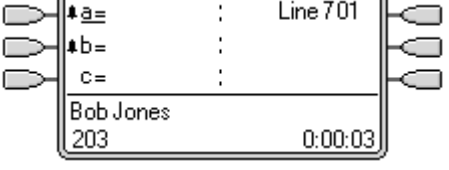
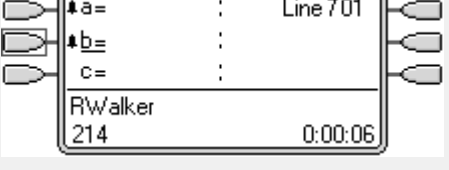
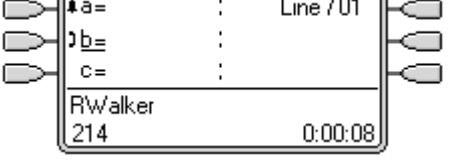
	<p><b>Phone Idle</b> The phone is idle. The current selected button has been determined by Idle Line Preference as the first available idle call appearance button. This is shown by the _ underscore next to that button.</p>
	<p><b>First Call Alerting</b> A call for the user arrives. It alerts on the first available call appearance button. Ringing Line Preference uses this as the currently selected button as it is the only alerting call.</p>
	<p><b>Second Call Alerting</b> Another call for the user arrives. It alerts on the next available call appearance button. As the first call has been alerting longer, under Ringing Line Preference it retains the currently select button status.</p>
	<p><b>The User Presses the Second Call Appearance</b> Pressing the second call appearance overrides ringing line preference and assigns current selected button status to the button without actually answering the call. The details of the caller are displayed.</p>
	<p><b>The User Answers the Call</b> The user can press the button again to answer the call or just go off-hook to answer as it is now the currently selected button.</p>

Related links

[Appearance Button Operation](#) on page 1079

## Auto Hold

Auto Hold is a system wide feature that affects all appearance button users. This feature determines what happens when a user, who is already on a call, presses another appearance button. The options are:

- If **Auto Hold** is **off**, the current call is disconnected.
- If **Auto Hold** is **on**, the current call is placed on hold.

On Release 4.0 and higher systems **Auto Hold** is **on** by default. On previous levels of system software the default for US was **off**.

### Auto Hold Example 1

In this example, the user has two calls currently shown on call appearance buttons. **Answer Pre-Select** is off.

	<ol style="list-style-type: none"> <li>1. This user has three call appearance buttons. They have answer one call and are still connected to it, shown by the 📞 icon. A second call is now alerting on their second call appearance button, shown by the ⚡ icon.</li> <li>2. What happens when the user presses the second call appearance key is determined by the system's <b>Auto Hold</b> setting:</li> </ol>
	<p><b>Auto Hold On</b> When the second call appearance key is pressed, that call is answered and the first call is put on hold, shown by the 📞⚡ icon. The user can switch between calls using the call appearance buttons and make/receive other calls if they have additional call appearance buttons</p>
	<p><b>Auto Hold Off</b> When the second call appearance key is pressed, that call is answered and the first call is disconnected.</p>

### Related links

[Appearance Button Operation](#) on page 1079

## Ring Delay

Ring delay can be applied to appearance buttons. This option can be used with all types of appearance buttons and can be selected separately for each appearance button a user has. Using

ring delay does not affect the buttons visual alerting through the display and display icons or button lamps.

Ring delay is typically used with line appearance buttons for lines which a user wants to monitor but does not normally answer. However ring delay can be applied to any type of appearance button.

The selectable ring delay options for an appearance button are listed below. The option is selected as part of the normal button programming process.

**Immediate** Provide audible alerting as per normal system operation.

**Delayed Ring** Only provide audible alerting after the system ring delay or, if set, the individual user's ring delay.

**No Ring** Do not provide any audible alerting.

There are two possible sources for the delay used when delayed ringing is selected for a button.

System | Telephony | Telephony | Ring Delay: Default = 5 seconds, Range 1 to 98 seconds. This is the setting used for all users unless a specific value is set for an individual user.

User | Telephony | Multi-line Options | Ring Delay: Default = Blank (Use system setting), Range 1 to 98 seconds. This setting can be used to override the system setting. It allows a different ring delay to be set for each user.

## Notes

**Calls That Ignore Ring Delay** Ring delay is not applied to hold recall calls, park recall calls, transfer return calls, voicemail ringback calls and automatic callback calls. For phones using Internal Twinning, ring delay settings are not applied to calls alerting at a secondary twinned extension (except appearance buttons set to **No Ring** which are not twinned).

**Auto Connect Calls** Ring delay is applied to these calls before auto-connection. This does not apply to page calls.

**Multiple Alerting Buttons** Where a call is presented on more than one button on a user's phone, see Multiple Alerting Buttons, the shortest delay will be applied for all the alerting buttons. For example, if one of the alerting buttons is set to **Immediate**, that will override any alerting button set to **Delayed Ring**. Similarly if one of the alerting buttons is set to **No Ring**, it will be overridden if the other alerting button is set to **Immediate** or **Delayed Ring**.

**Line Appearance Buttons** Calls routed to a user that could potentially be presented on both a call appearance button and a line appearance button are only presented on the line appearance button. In this scenario, the ring delay settings used is that of the first free call appearance button.

**Delay on Analog Lines** Analog lines set to Loop Start ICLID already delay ringing whilst the system waits for the full ICLID in order to resolve incoming call routing. In this scenario the ring delay operates in parallel to the routing delay.

**Ring Delay and Ringing Line Preference** Appearance buttons can be set to **Delayed Ring** or **No Ring**. However ringing line preference is still applied to alerting buttons even if set to **Delayed Ring** or **No Ring**.

The user's **Delayed Ring Preference** setting is used to determine whether ringing line preference is used with or ignores buttons that are alerting but have **Delayed Ring** or **No Ring** set.

Ring Delay Example 1

In this example, the user has a line appearance button set but configured to no ring.

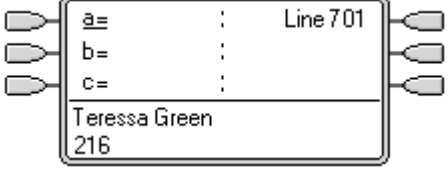
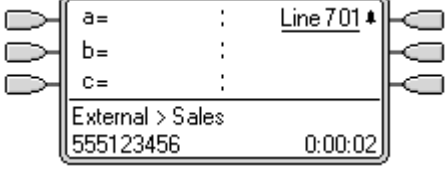
 <p>The phone display shows three buttons labeled 'a=', 'b=', and 'c=' on the left. To the right, it says 'Line 701'. Below a horizontal line, the name 'Teresa Green' and the number '216' are displayed.</p>	<p><b>Phone Idle</b> The phone is idle. The current selected button has been determined by Idle Line Preference as the first available call appearance button. This is shown by the _ underscore next to that button.</p>
 <p>The phone display shows the same three buttons. The 'Line 701' text now has a small downward arrow next to it. Below the horizontal line, it shows 'External &gt; Sales', the number '555123456', and a timer '0:00:02'.</p>	<p><b>Incoming Call Alerting on the Line</b> An incoming call arrives on the line and begin to alert somewhere on the system. The user's line appearance button shows this visually but doesn't ring audibly. Ringing line preference would makes the line appearance the user's currently selected button and therefore they would answer the line if they went off-hook.</p>

**Related links**

[Appearance Button Operation](#) on page 1079

## Delayed Ring Preference

When a call is alerting at an idle phone, by default Ringing Line Preference sets the call as the currently selected button and if the user then goes off-hook they will answer that call.

In most situations this is acceptable as the user hears ringing which informs them that there is a call waiting to be answered. If the user wants to make a call instead, they can press another call appearance button to go off-hook on that other button.

When ring delay is being used there can potentially be a problem if the user lifts the handset to make a call without looking at the display. If they do this while the a call is alerting silently on a button with ring delay, the user will actually answer the waiting call rather than get dial tone to make a call.

Once the call alerting on a button has currently selected call status, it retains that status even if a prior call on a button with ring delay applied comes out of its ring delay period.

Delayed Ring Preference Example 1

In this example the user has a line appearance button for a line they monitor. This line appearance button has been set to no ring as the user occasionally need to use that line but does not normally answer calls on that line.

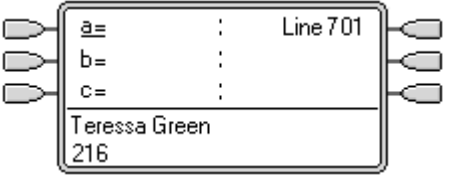
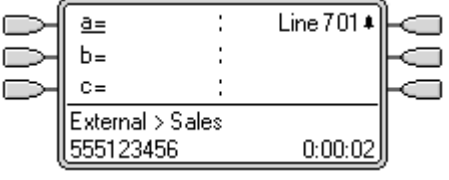
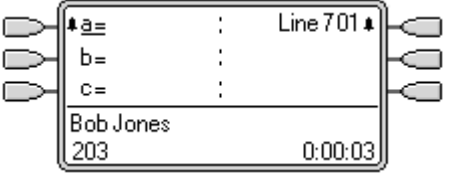
	<p><b>Phone Idle</b> The phone is idle. The current selected button has been determined by Idle Line Preference as the first available call appearance button. This is shown by the _ underscore next to that button.</p>
	<p><b>Incoming Call Alerting on the Line</b> An incoming call arrives on the line and begin to alert somewhere on the system. The user's line appearance button shows this visually but doesn't ring audibly.</p> <p>Normally ringing line preference would make the line appearance the user's currently selected button and therefore they would answer the line if they went off-hook expecting to make a call.</p> <p>However, because <b>Delayed Ring Preference</b> is on for the user, ringing line preference is not applied and idle line preference makes their current selected button the first call appearance. If the user were to go off-hook they would be making a call on that call appearance.</p>
	<p><b>Call Alerting for the User</b> A call for the user arrives. It alerts on the first available call appearance button. Ringing line preference is applied and makes that the users currently selected button. If the user goes off-hook now that will answer the call on the call appearance and not the line appearance.</p>

Delayed Ring Preference Example 2

This is similar to the previous example except that the user and the line has been configured for a 15 second ring delay. This informs the users that the line has not been answered for some reason and allows them to answer it by just going off-hook.

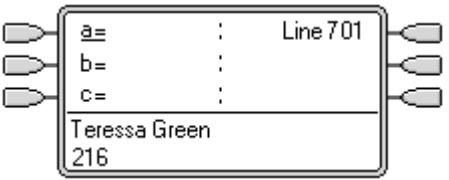
	<p><b>Phone Idle</b> The phone is idle. The current selected button has been determined by Idle Line Preference as the first available call appearance button. This is shown by the _ underscore next to that button.</p>
-------------------------------------------------------------------------------------	---------------------------------------------------------------------------------------------------------------------------------------------------------------------------------------------------------------------------

*Table continues...*

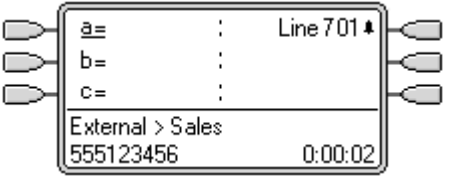
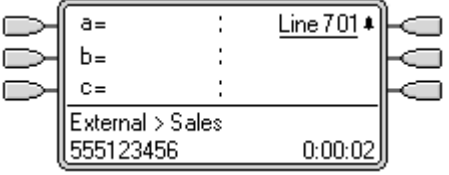
	<p><b>Incoming Call Alerting on the Line</b> An incoming call arrives on the line and begin to alert somewhere on the system. The user's line appearance button shows this visually but doesn't ring audibly. Because <b>Delayed Ring Preference</b> is on for the user, ringing line preference is not applied and idle line preference makes their current selected button the first call appearance. If the user were to go off-hook they would be making a call on that call appearance.</p>
	<p><b>Call Continues Alerting</b> When the ring delay for the line appearance expires, if no other call has taken ringing line preference it becomes the current selected call and will be answered if the user goes off-hook.</p>

**Related links**

[Appearance Button Operation](#) on page 1079

## Collapsing Appearances

This topic covers what happens when a user with several calls on different appearance buttons, creates a conference between those calls. In this scenario, the call indication will collapse to a single appearance button and other appearance buttons will return to idle. The exception is any line appearance buttons involved which will show 'in use elsewhere'.

**Collapsing Appearances Example 1**

In this example, the user will setup a simple conference. **Ringing Line Preference** and **Idle Line Preference** are set for the user. **Auto Hold** for the system is on. **Answer Pre-Select** is off.

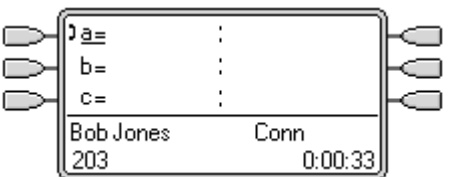
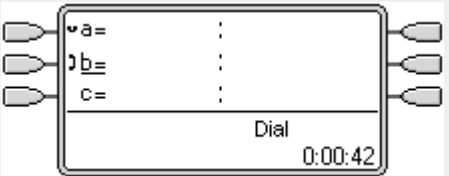
	<p><b>Initial Call</b> The user has a call in progress, shown on their first call appearance button. It is decided to conference another user into the call.</p>
	<p><b>Make Conference Enquiry</b> Pressing the <b>CONFERENCE</b> button on the users phone automatically places the current call on hold and takes the phone off hook on the next available call appearance.</p>

*Table continues...*

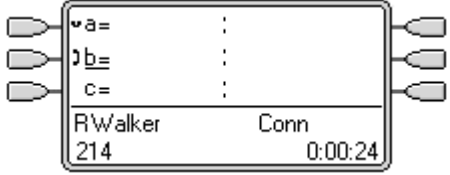
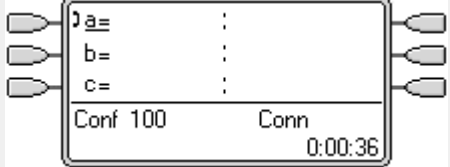

 <p>The phone display shows three appearance buttons labeled 'a=', 'b=', and 'c=' on the left. On the right, there is a 'CONFERENCE' button with three small squares. The call information at the bottom reads 'RWalker Conn' and '214 0:00:24'.</p>	<p><b>Enquiry in Progress</b> The other extension has answered and is invited to join a conference call. The user presses the <b>CONFERENCE</b> button on their phone again.</p>
 <p>The phone display now shows a single appearance button labeled 'a=' on the left. The call information at the bottom reads 'Conf 100 Conn' and '0:00:36'.</p>	<p><b>Conference Starts/Call Appearances Collapse</b> The conference call has started. The call appearances have collapsed to a single appearance.</p>

### Related links

[Appearance Button Operation](#) on page 1079

## Joining Calls

Appearance buttons can be used to "join" existing calls and create a conference call. A user can join calls that are shown on their phone as 'in use elsewhere'.

This feature is often referred to as 'bridging into a call'. However this causes confusion with Bridged appearance buttons and so the term should be avoided.

The ability to join calls is controlled by the following feature which can be set for each user:

- **Cannot be Intruded:** Default = On If this option is set on for the user who has been in the call the longest, no other user can join the call. If that user leaves the call, the status is taken from the next internal user who has been in the call the longest. The exceptions are:
  - Voicemail calls are treated as **Cannot be Intruded** at all times.
  - When an external call is routed off switch by a user who then leaves the call, the **Cannot be Intruded** status used is that of the user who forwarded the call off switch.
  - Any call that does not involve an internal user at any stage is treated as **Cannot be Intruded** on. For example:
    - When an external call is routed off switch automatically using a short code in the incoming call route.
    - multi-site network calls from other systems that are routed off-switch.
    - VoIP calls from a device not registered on the system.
- The **Can Intrude** setting is not used for joining calls using appearance buttons.

The following also apply:

**Inaccessible** In addition to the use of the **Cannot be Intruded** setting above, a call is inaccessible if:

- The call is still being dialed, ringing or routed.
- It is a ringback call, for example a call timing out from hold or park.
- If all the internal parties, if two or more, involved in the call have placed it on hold.
- **Conferencing Resources** The ability to bridge depends on the available conferencing resource of the system. Those resources are limited and will vary with the number of existing parties in bridged calls and conferences. The possible amount of conferencing resource depends on the system type and whether Conferencing Center is also installed.
- **Conference Tone** When a call is joined, all parties in the call hear the system conferencing tones. By default this is a single tone when a party joins the call and a double-tone when a party leaves the call. This is a system setting.
- **Holding a Bridged Call** If a user puts a call they joined on hold, it is their connection to the joined call (conference) that is put on hold. The other parties within the call remain connected and can continue talking. This will be reflected by the button status indicators. The user who pressed hold will show 'on hold here' on the button they used to join the call. All other appearance users will still show 'in use here'.
- **Maximum Two Analog Trunks** Only a maximum of two analog trunks can be included in a conference call.
- **Parked Calls** A Line Appearance button may indicate that a call is in progress on that line. Such calls to be unparked using a line appearance.

Joining Example 1: Joining with a Bridged Appearance

In this example, the user joins a call using a bridged appearance button. **Answer Pre-Select** is off.

	<p><b>User with Bridged Appearance Buttons</b> The user has bridged appearance buttons that match their colleagues call appearance buttons.</p>
	<p><b>Call on Bridged Appearance</b> The colleague has a call in progress on their first call appearance. This is matched on the first bridged appearance button.</p>
	<p><b>User Joins the Call</b> Pressing the bridged appearance button will take our user off hook and join them into their colleagues call, creating a conference call.</p>

Joining Example 2: Joining with a Line Appearance

In this example, the user joins a call by pressing a line appearance button. **Answer Pre-Select** is off.

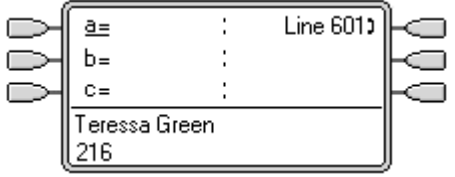
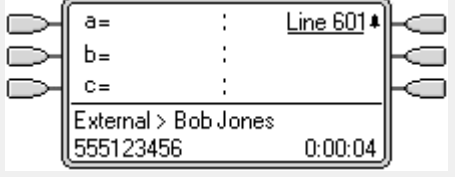
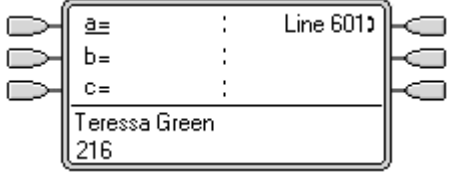
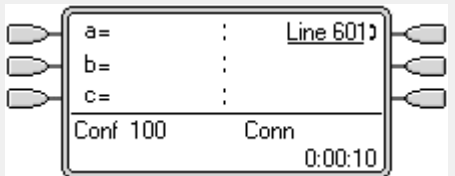
	<p><b>Line Goes Active</b> A call is active on the line with line ID number 601.</p> <p>If this is an incoming call, it will show active but will not alert until its call routing has been determined. On ICLID analog lines, alerting is delayed until the ICLID that might be used to do that routing has been received.</p>
	<p><b>Line Appearance Alerting</b> The call routing is completed and the call is now ringing against its target. The line appearance also begins alerting and Ringing Line Preference has made it the current selected button.</p>
	<p><b>Call Answered</b> Alerting on the line appearance has stopped but the line is still active. This indicates that the call has probably been answered. As our user's phone is idle, Idle Line Preference has returned the current select button to the first available call appearance button.</p>
	<p><b>User Joins the Call</b> Our extension user has been asked by their colleague to join the call just answered on line 601. By pressing the line appearance button they have joined the call on that line and created a conference call.</p>

#### Related links

[Appearance Button Operation](#) on page 1079

## Multiple Alerting Appearance Buttons

In some scenarios, it may be potentially possible for the same call to alert on several appearance buttons. In this case the following apply:

- **Line appearance buttons override call and bridged appearance buttons** In cases where a call on a line goes directly to the user as the incoming call route's destination, the call will only alert on the line appearance. In this scenario the ring delay settings used is that of the first free call appearance button.
- **A call can alert both call appearance, line appearance and bridged appearance buttons** The most common example of this will be hunt group calls where the hunt group members also have bridged call appearances to each other. In this case the button used to answer the call will remain active whilst the other button will return to idle.

- **Calls on a line/bridged appearance buttons can also alert on call coverage button** In this case alerting on the call coverage button may be delayed until the covered user's **Individual Coverage Time** has expired.
- **Ringling Line Preference Order** When a call alerts on several of the user's appearance buttons and **Ringling Line Preference** is set for the user, the order used for current selected button assignment is:
  1. Call appearance.
  2. Bridged appearance.
  3. Call coverage.
  4. Line appearance.

**Example** A user has a call to a covered user alerting initially on a line appearance button. **Ringling Line Preference** will assign current selected button status to the line appearance. When the same call also begins to alert on the call coverage appearance button, current selected button status switches to the call coverage appearance button.

**Ring Delay** Where ring delays are being used, the shortest delay will be applied for all the alerting buttons. For example, if one of the alerting buttons is set to **Immediate**, that will override any alerting button set to **Delayed Ring**. Similarly if one of the alerting buttons is set to **No Ring**, it will be overridden if the other alerting button is set to **Immediate** or **Delayed Ring**.

#### Related links

[Appearance Button Operation](#) on page 1079

---

## Twining

Twining is a mechanism that allows an user to have their calls alert at two phones. The user's normal phone is referred to as the primary, the twinned phone as the secondary.

By default only calls alerting on the primary phone's call appearance buttons are twinned. For internal twining, the system supports options to allow calls alerting on other types of appearance buttons to also alert at the secondary phone. These options are set through the **User | Twining** section of the system configuration and are **Twin Bridge Appearances**, **Twin Coverage Appearances** and **Twin Line Appearances**. In all cases they are subject to the secondary having the ability to indicate additional alerting calls.

Call alerting at the secondary phone ignoring any Ring Delay settings of the appearance button being used at the primary phone. The only exception is buttons set to No Ring, in which case calls are not twinned.

#### Related links

[Appearance Button Operation](#) on page 1079

---

## Busy on Held

For a user who has **Busy on Held** selected, when they have a call on hold, the system treats them as busy to any further calls. This feature is intended primarily for analog phone extension users. Within Manager, selecting **Busy on Held** for a user who also has call appearance keys will cause a prompt offering to remove the **Busy on Held** selection.

### Related links

[Appearance Button Operation](#) on page 1079

---

## Reserving a Call Appearance Button

Functions such as transferring calls using a **Transfer** key require the user to have at least one available call appearance button in order to complete the outgoing call part of the process. However, by default all call appearance buttons are available to receive incoming calls at all times. Through the system configuration it is possible to reserve the user's last call appearance button for making outgoing calls only.

1400, 1600, 9500 and 9600 Series telephone users can put a call on hold pending transfer if they already have held calls even if they have no free call appearance button available. See Context Sensitive Transfer.

### Reserving a Call Appearance

The method for doing this depends on the system software level.

**Pre-4.0 IP Office:** On the **User | Source Numbers** tab, enter the line **RESERVE\_LAST\_CA=** .

**Release 4.0+:** On the **User | Telephony | Multi-line Options** tab, select the option **Reserve Last CA**.

### Related links

[Appearance Button Operation](#) on page 1079

---

## Logging Off and Hot Desking

Users can be setup to log in and log out at different phones, this is called 'hot desking'. All the users settings, including their extension number, are transferred to the phone at which the user is logged in. This includes their key and lamp settings and appearance buttons.

This type of activity has the following effect on appearance buttons:

If logged out, or logged in at a phone that doesn't support appearance button functions:

- Bridged appearances set to the user will be inactive.

- Call coverage set to the user will still operate.

If logged in at a phone with fewer buttons than programmed for the user:

- Those buttons which are inaccessible on the logged in phone will be inactive.
- Any bridged appearances to those button from other users will be inactive.

#### Remote Hot Desking

Release 4.0+ supports, through the addition of license keys, users hot desking between systems within a multi-site network. However, the use of appearance buttons (call coverage, bridged appearance and line appearance) within a multi-site network is not supported. Therefore when a user logs in to a remote system, any such button that they have will no longer operate. Similarly any button that other users have with the remote user as the target will not operate.

#### Related links

[Appearance Button Operation](#) on page 1079

---

## Applications

A number of system applications can be used to make, answer and monitor calls. These applications treat calls handled using key and lamp operation follows:

**SoftConsole** These applications are able to display multiple calls to or from a user and allow those calls to be handled through their graphical interface.

- All calls alerting on call appearance buttons are displayed.
- Calls on line, call coverage and bridged appearance buttons are not displayed until connected using the appropriate appearance button
- Connected and calls held here on all appearance button types are displayed.

#### Related links

[Appearance Button Operation](#) on page 1079

---

## Programming Appearance Buttons

### About this task

This section covers the programming of appearance buttons for users into existing system configurations.

**Appearance Functions** The functions **Call Appearance**, **Bridged Appearance**, **Coverage** and **Line Appearance** are collectively known as "appearance functions". For full details of their operation and usage refer to the Appearance Button Operation section. The following restrictions must be observed for the correct operation of phones.

Appearance functions programmed to buttons without suitable status lamps or icons are treated as disabled. These buttons are enabled when the user logs in on a phone with suitable buttons in those positions.

Line appearance buttons require line ID numbers to have been assigned, see Programming Line Appearance Numbers. The use of line appearances to lines where incoming calls are routed using DID (DDI) is not recommended.

**How many buttons are allowed?** The recommended limits depend on the type of system. The are 10 for IP500 V2 systems, 20 for Server Edition and 40 for Server Edition Select. The limits are applied as follows:

- Number of bridged appearances to the same call appearance.
- Number of line appearances to the same line.
- Number of call coverage appearances of the same covered user.

### Programming Appearance Buttons Using Manager

If only button programming changes are required, the configuration changes can be merged back to the system without requiring a reboot.

### Procedure

1. Start Manager and load the current configuration from the system.
2. Locate and select the user for whom appearance buttons are required.
3. Select **Button Programming**.

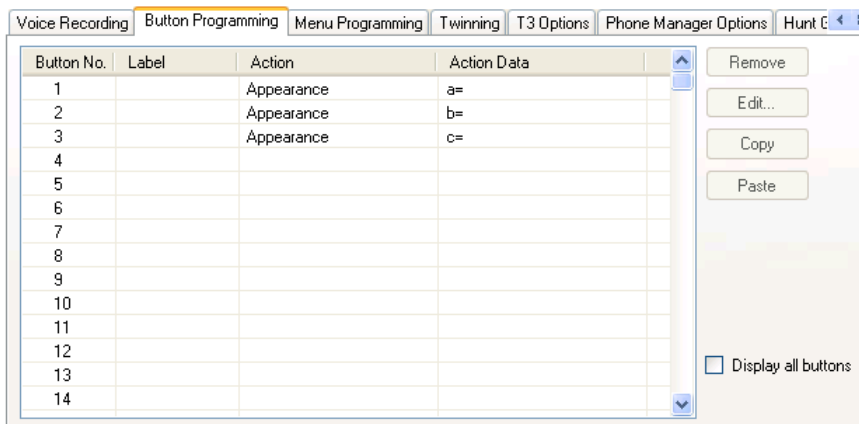

The number of buttons displayed is based on the phone associated with the user when the configuration was loaded from the system. This can be overridden by selecting **Display all buttons**.

4. For the required button, click the button number and then click **Edit**.
5. Click the ... button.

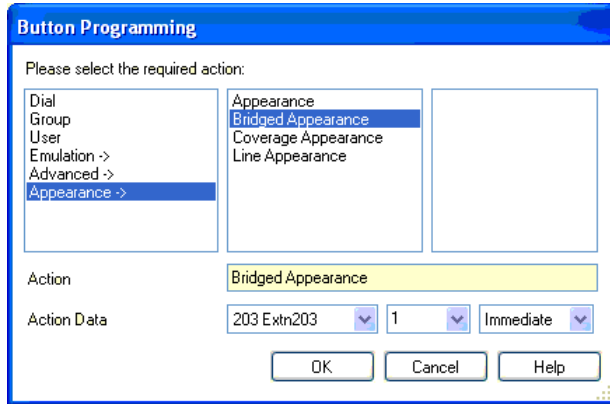

6. From the list of options that appears, click **Appearance**.
7. Select the type of appearance button required.
8. Use the **Action Data** drop-down fields to select the required settings.  
Click **OK**.
9. Repeat for any additional call appearance buttons required.  
Click **OK**.
10. Repeat for any other users requiring appearance buttons.

### Related links

- [Appearance Button Operation](#) on page 1079
- [Appearance Function System Settings](#) on page 1120
- [Appearance Function User Settings](#) on page 1121
- [Programming Line Appearance ID Numbers](#) on page 1122
- [Outgoing Line Programming](#) on page 1124

---

## Appearance Function System Settings

System settings are applied to all users and calls. The system settings that affect appearance operation are found on the System | Telephony tabs and are:

- Auto Hold
- Conferencing Tone
- Ring Delay
- Visually Differentiate External Call

### Related links

- [Programming Appearance Buttons](#) on page 1118



## Appearance Function User Settings

User settings are applied separately to each individual user. In addition to button programming, the following user settings are applicable to appearance button operation:

**Cannot be Intruded:** Default = On. This feature controls whether other users can use their appearance buttons to join the users call. It applies when the user is the longest present internal party already within the call.

- **Individual Coverage Time (secs):** Default = 10 seconds, Range 1 to 99999 seconds.  This function sets how long the phone will ring at your extension before also alerting at any call coverage users. This time setting should not be equal to or greater than the **No Answer Time** applicable for the user.
- **Ring Delay:** Default = Blank (Use system setting). Range = 0 (use system setting) to 98 seconds. This setting is used when any of the user's programmed appearance buttons is set to Delayed ringing. Calls received on that button will initially only alert visually. Audible alerting will only occur after the ring delay has expired.
- **Coverage Ring:** Default = Ring. This field selects the type of ringing that should be used for calls alerting on any the user's call coverage and bridged appearance buttons. **Ring** selects normal ringing. **Abbreviated Ring** selects a single non-repeated ring. **No Ring** disables audible ringing. Note that each button's own ring settings (**Immediate**, **Delayed Ring** or **No Ring**) are still applied.

The ring used for a call alerting on a call coverage or bridged appearance button will vary according to whether the user is currently connected to a call or not.

- If not currently on a call, the **Coverage Ring** setting is used.
- If currently on a call, the quieter of the **Coverage Ring** and **Attention Ring** settings is used.

Attention Ring Setting	Coverage Ring Setting		
	<b>Ring</b>	<b>Abbreviated</b>	<b>Off</b>
<b>Ring</b>	Ring	Abbreviated	Off
<b>Abbreviated</b>	Abbreviated	Abbreviated	Off

- **Attention Ring:** Default = Abbreviated Ring. This field selects the type of ringing that should be used for calls alerting on appearance buttons when the user already has a connected call on one of their appearance buttons. **Ring** selects normal ringing. **Abbreviated Ring** selects a single ring. Note that each button's own ring settings (**Immediate**, **Delayed Ring** or **No Ring**) are still applied.
- **Ring Line Preference:** Default = On. For users with multiple appearance buttons. When the user is free and has several calls alerting, ringing line preference assigns currently selected button status to the appearance button of the longest waiting call. Ringing line preference overrides idle line preference.
- **Idle Line Preference:** Default = On. For users with multiple appearance buttons. When the user is free and has no alerting calls, idle line preference assigns the currently selected button status to the first available appearance button.

- **Delayed Ring Preference:** Default = Off. This setting is used in conjunction with appearance buttons set to delayed or no ring. It sets whether ringing line preference should use or ignore the delayed ring settings applied to the user's appearance buttons.

When on, ringing line preference is only applied to alerting buttons on which the ring delay has expired.

When off, ringing line preference can be applied to an alerting button even if it has delayed ring applied.

- **Answer Pre-Select:** Default = Off. Normally when a user has multiple alerting calls, only the details and functions for the call on currently selected button are shown. Pressing any of the alerting buttons will answer the call on that button, going off-hook will answer the currently selected button. Enabling **Answer Pre-Select** allows the user to press any alerting button to make it the current selected button and displaying its call details without answering that call until the user either presses that button again or goes off-hook. Note that when both **Answer Pre-Select** and **Ringing Line Preference** are enabled, once current selected status is assigned to a button through ringing line preference it is not automatically moved to any other button.
- **Reserve Last CA:** Default = Off. Used for users with multiple call appearance buttons. When selected, this option stops the user's last call appearance button from being used to receive incoming calls. This ensures that the user always has a call appearance button available to make an outgoing call and to initiate actions such as transfers and conferences.

1400, 1600, 9500 and 9600 Series telephone users can put a call on hold pending transfer if they already have held calls even if they have no free call appearance button available. See Context Sensitive Transfer.

**Abbreviated Ring:** This option has been replaced by the **Attention Ring** setting above.

#### Related links

[Programming Appearance Buttons](#) on page 1118

---

## Programming Line Appearance ID Numbers

Line appearances are supported for analog, E1 PRI, T1, T1 PRI, and BRI PSTN trunks. They are not supported for E1R2, QSIG and IP trunks.

Note that setting and changing line settings including line appearance ID numbers requires the system to be rebooted.

#### Related links

[Programming Appearance Buttons](#) on page 1118

## Automatic Renumbering

### About this task Procedure

1. Select **Tools | Line Renumber**.

2. Select the starting number required for line numbering and click **OK**.
3. All lines that support **Line Appearance ID** will be numbered in sequence.

## Manual Renumbering

### About this task

#### Procedure

1. Start Manager and load the current configuration from the system.
2. Select  **Line**.
3. Select the line required.

The tab through which line appearance ID numbers are set will vary depending on the type of line. A couple of examples are shown below.

#### a. Analog Line

On the **Line Settings** tab select **Line Appearance ID** and enter the ID required.

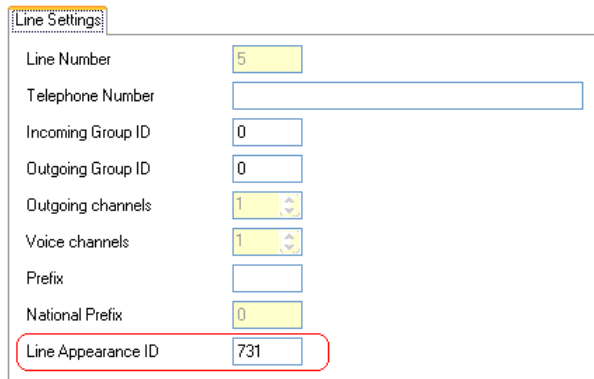

Line Settings	
Line Number	5
Telephone Number	
Incoming Group ID	0
Outgoing Group ID	0
Outgoing channels	1
Voice channels	1
Prefix	
National Prefix	0
Line Appearance ID	731

#### b. Basic/Primary Rate Trunks

On the Channels tab select the individual channel and click Edit. Select **Line Appearance ID** and enter the required ID, then click **OK**. Repeat for all the channels required.

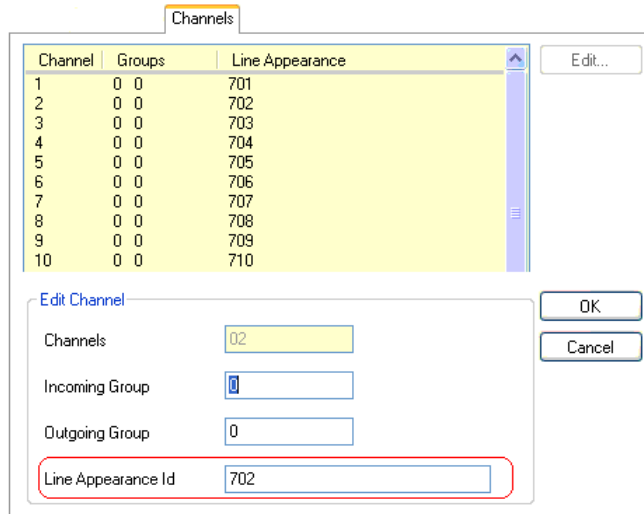

4. Click **OK** and repeat for any other lines.

---

## Outgoing Line Programming

Assigning line ID numbers to lines and associating line appearance buttons to those lines is sufficient for answering incoming calls on those lines. However, to use line appearance buttons for outgoing calls may require further programming.

**Short Codes and Outgoing Line Appearance Calls** Once a line has been seized using a line appearance button, short code matching is still applied to the number dialed. That can include user, system and ARS short codes.

The short codes matching must resolve to an off-switch number suitable to be passed direct to the line.

The final short code applied must specify a 'dial' feature. This allows call barring of specific matching numbers to be applied using short codes set to features such as 'Busy'.

### Related links

[Programming Appearance Buttons](#) on page 1118

# Part 7: Miscellaneous

# Chapter 22: Overview of Data Routing

The system is a network router. In this role it can connect users on its LAN to remote services by using WAN links and telephone trunk connections. It can also allow users to dial-in and then act as if they were using a PC on the LAN.

As well as being a network router, the system is a telephone system. These dual roles allow it to support a range of functions that involve traffic between the network and telephony interfaces. These functions use internal data channels. The number of internal data channels that can be connected from the system's LAN interface to its telephony interface at any time is restricted.

An internal data channel is a connection between the system's telephony and LAN interfaces. For example a Voicemail connection, an internet connection or a RAS user.

Calls using a VCM channel do not use a data channel.

The number of data channels in use does not necessarily match the number of users:

- Several LAN network users, browsing the internet using the same service to an ISP would be a single data channel.
- Several dial-in network users would each have a separate data channel.

The maximum number of data channels that can be simultaneously in use for voicemail is restricted. These channels also require entry of an appropriate license.

The restriction depends on the type of control unit being used.

System Control Unit	Internal Data Channels	Maximum Data Channels for Voicemail
<b>Small Office Edition</b>	18	10
<b>IP403</b>	18	10
<b>IP406 V1</b>	24	20
<b>IP406 V2</b>	40	20
<b>IP412</b>	100	30
<b>IP500 V2</b>	48[1]	40

1. Reduced to 44 when an IP500 V2 4-Port Expansion card is installed.

## Related links

[Network Address Translation \(NAT\)](#) on page 1127

[Dynamic Host Configuration Protocol \(DHCP\)](#) on page 1127

[Simple ISDN Internet Connection](#) on page 1128

[ISDN Link Between IP Offices](#) on page 1128

[Using a Dedicated T1/PRI ISP Link](#) on page 1129

[Remote Access](#) on page 1132

[Creating a VoIP Link via the WAN Port Using PPP](#) on page 1135

---

## Network Address Translation (NAT)

NAT allows the addresses used within your LAN to be replaced by a different address when connecting to an external service.

Typically a service provider will allocate you a single IP address to be used when connecting to their service. NAT allows all your user's traffic to appear to be coming from that single address without having to change any of your user's real addresses. This is useful as internally most networks use addresses that have been reserved for public use within networks but are not valid for routing across the internet (since the same addresses may be being used on other networks). Also as stated it allows multiple users to use the same service simultaneously.

The use of NAT is automatically enabled if the system Service being used includes an IP address that is not in the same domain as the its LAN1 IP address.

An exception to the above applies for systems with two LAN's, LAN1 and LAN2. For these units, on each LAN, **Enable NAT** can be selected and then applied to traffic between the two LAN's.

### Related links

[Overview of Data Routing](#) on page 1126

---

## Dynamic Host Configuration Protocol (DHCP)

The system can act as a simple DHCP server. When switched on with a defaulted configuration, the Control Unit request IP address information from a DHCP server. If it gets no response it assumes the role of DHCP server for the LAN.

In DHCP Server mode, by default the Control Unit issues itself the address 192.168.42.1. It allocates 200 addresses for DHCP clients, 192.168.42.1 to 19.168.42.200. This leaves 192.168.42.201 to 192.168.42.254 available for any computers that need to be allocated a fixed or static IP address. 192.168.42.255 is not used as this is a broadcast address for the LAN.

### Related links

[Overview of Data Routing](#) on page 1126

---

## Simple ISDN Internet Connection

In this example, we want all non-local data traffic to be routed to the Internet. The Internet Service Provider (ISP) has provided the account details required. Using the system's Network Address Translation (NAT), a single account can be used for all users.

Select  **Service** and add a normal service. Change the following settings and click **OK**.

**Name:** Internet

**Account Name:** As provided by the ISP.

**Password:** As provided by the ISP.

**Telephone Number:** As provided by the ISP.

Check **Request DNS**.

Select  **IP Route** and add a new route. Change the following settings and click **OK**.

1. Leave the **IP Address** and **IP Mask** blank. This will then match any data traffic that isn't matched by any other IP Route record.
2. Select the service created above as the **Destination**.

**Alternate** In the example above, a default IP Route was created which then routed all traffic to the required Service. An alternate method to do this with system is to select Default Route within the Service settings.

### Related links

[Overview of Data Routing](#) on page 1126

---

## ISDN Link Between IP Offices

To create a data link between two sites via ISDN configure the Control Unit as per the following example:

At Site A on IP address 192.168.43.1

1. **Create a Normal Service:** The Service name can be any text and is used to identify this particular Service. The Account Name and password are presented to the remote end, therefore must match the User name and password configured at Site B. The Telephone Number is the number of the remote end.
2. **Create an IP Route:** In the IP Address field enter the network address of the remote end, not the IP address of the Control Unit. Under Destination select the Service created above.
3. **Create a User:** Under the Dial In tab tick Dial In On. This User account is used to authenticate the connection from the Site B. Note that as the Service and User have the same names, these two configuration forms are automatically linked and become an



Intranet Service. The User password is displayed at the bottom of the Service tab as the Incoming Password.

4. **Setup RAS:** Check the default RAS settings "Dial In" are available, otherwise create a new one. If the RAS settings are given the same name as the Service and User they are automatically linked and become a WAN Service. Ensure that the Encrypted Password option is not checked when using a WAN Service.
5. **Setup an Incoming Call Route:** Check the default Incoming Call Route is available, otherwise create a new one. If the Incoming Number is left blank, the Incoming Call Route accepts data calls on any number. Under Destination select the RAS service created above. The Bearer Capability should be AnyData.

At Site B on IP address 192.168.45.1

Repeat the above process but altering the details to create an route from Site B to Site A.

#### Related links

[Overview of Data Routing](#) on page 1126

---

## Using a Dedicated T1/PRI ISP Link

This section shows an example of a dedicated WAN PPP link to an Internet Service Provider (ISP) over a set of T1 or T1 PRI line channels. The ISP must support this mode of connection and will need to provide details of the required settings. If multiple channels are to be used, then the ISP must support Multilink PPP.

#### Related links

[Overview of Data Routing](#) on page 1126

---

## Tasks for Using a Dedicated T1/PRI ISP Link

### About this task

#### Procedure

1. Create a New WAN Service
2. Create the Virtual WAN Port
3. Create an IP Route
4. T1 PRI Trunk



---

## Create a New WAN Service

### About this task

A service is used to define connection settings such as name, password, bandwidth, etc.

## Procedure

1. Select  **Service** to display the existing services.
2. Click on  and select **WAN Service**.
3. Select the **Service** tab.
4. In the **Name** field enter an appropriate name, such as “**Internet**”.  
Note that the system will also automatically create User record and a RAS record with the same name.
5. Enter the **Account Name**, **Password** and **Telephone Number** details provided by the ISP.
6. For the **Firewall Profile** select the firewall created previously.
7. Click the **Bandwidth** tab.
  - a. Set the **Maximum No. of Channels** to the maximum number of channels that the service should use.  
In this example, 12 channels were used.
  - b. Leave all the other records at their default values.
  - c. If the ISP has allocated IP address details these are entered through the IP tab.  
If the IP Address and IP Mask define a different domain from the system LAN, then NAT is automatically applied.
8. Click the **IP** tab.
  - a. In the **IP Address** field enter the IP address specified by the ISP.
  - b. In the **IP Mask** field enter the IP Mask specified by the ISP.
  - c. The settings shown are typical.  
The actual settings must match those required by the ISP. For example, if Cisco routers are being used then IPHC needs to be ticked.
9. Click the **PPP** tab.  
Ensure that the following options are selected. Leave all other options at their default settings.
  - **Multilink**.
  - **Compression Mode**: Disable.
  - **Callback Mode**: Disable.
  - **Access Mode**: Digital64
10. Click **OK**.



---

## Create the Virtual WAN Port

### About this task

In this stage, a WAN port is defined that actually uses T1 or T1 ISDN trunk channels.

### Procedure

1. Select  **WAN Port** to display existing ports.
2. Click on  and select **WAN Port**.
3. In the Name field, enter either **LINEx.y** where:
  - **LINE** must be in uppercase.
  - **x** is the line number. For a trunk card in Slot A, this will be 1. For a trunk card in Slot B, this will be 5.
  - **y** is the lowest numbered channel number to be used by the WAN link minus 1. For example, if the lowest channel to be used is channel 1 then  $y = 1 - 1 = 0$ .
4. In the **Speed** field, enter the total combined speed of the maximum number of channels sets in the Service.  
  
In this example, 12 channels x 64000 bits = 76800.
5. Set the **Mode** to **SyncPPP**.
6. In the **RAS Name** field, select the name used for the Service.
7. Click **OK**.



---

## Create an IP Route

### About this task

By creating an IP route with blank IP address details, it becomes the default route for outgoing IP traffic.

### Procedure

1. Select  **IP Route** to display existing routes.
2. Click on  and select **IP Route**.
3. Leave the **IP Address** and **IP Mask** fields blank.
4. In the **Destination** field, select the WAN service.
5. Leave the **Metric** at default value of 1.
6. Click **OK**.

7. **Configure the Line Channels** This stage of the process differs according to the type of trunk being used.
8. **T1 Trunk** Use the following for a T1 trunk.
9. Click  **Line** to display the existing lines.
10. Double-click on the line previously entered in the WAN Port settings.
11. Check that the **Channel Allocation** order matches that required by the ISP.  
Cisco routers typically use 1|24.
12. Select the channels to be used in the WAN PPP link and change their Channel Type to "Clear Channel 64k".
13. Click **OK**.
14. Click **OK** again.
15. Send the configuration to the system and reboot.

---

## T1 PRI Trunk

### About this task

Use the following for a T1 PRI trunk.

### Procedure

1. Click on  **Line** to display the list of existing lines.
2. Double-click on the line previously entered in the WAN Port settings.
3. Check that the **Channel Allocation** order matches that required by the ISP.  
Cisco routers typically use 1|23.
4. Select the channels to be used in the WAN PPP link and change their Admin to "Out of Service".
5. Click **OK**.
6. Click **OK** again.
7. Send the configuration to the system and reboot.

---

## Remote Access

The system support remote access for incoming data calls on trunks.

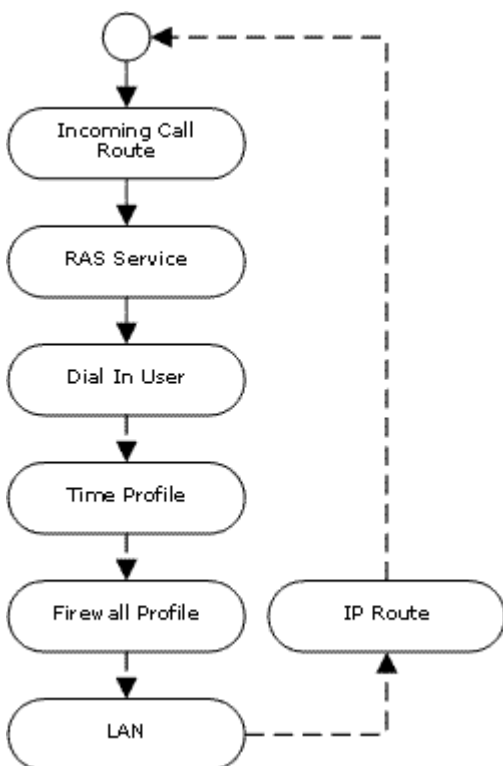
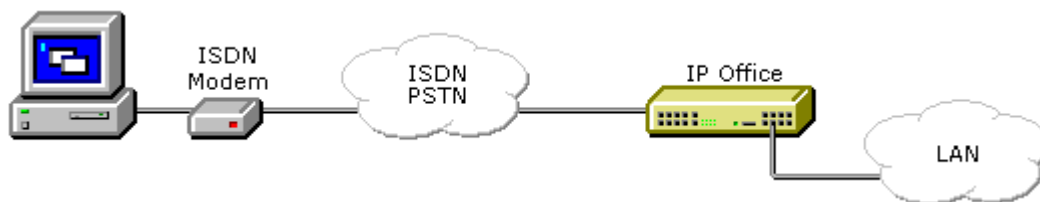

To do remote access, an incoming call is passed through the following elements of the system configuration.

**Incoming Call Route** An Incoming Call Route is used to match incoming remote access calls and pass them to a RAS service as the destination.

**RAS Service** The RAS service defines settings relating to the data traffic methods usable with the call.

**User** The user defines the name and password required for the RAS service. The user must have Dial In On enabled.

An **R** setting on the user's Source Numbers tab can be used to define the ICLID from which RAS calls are accepted.

**Time Profile** The user settings can specify a time profile. The time profile then controls when remote access is allowed.

 **Firewall Profile** The user settings can specify a firewall profile. The firewall profile then controls what traffic is allowed through the remote access connection.

**Static NAT** The system supports the use of Static NAT records in firewall profiles. These are used to translate external IP addresses to internal IP addresses.

 **System | LAN** The system can provide DHCP support for remote access connections when it is set to Server or Dial in modes. Alternatively the remote access client can use a static IP address on the system's subnet.

 **IP Route** If the remote access client uses a IP address that is from a different subnet from the system, then a IP route record is required for returning data. The RAS service is set as the destination.

### ISDN Remote Access Example

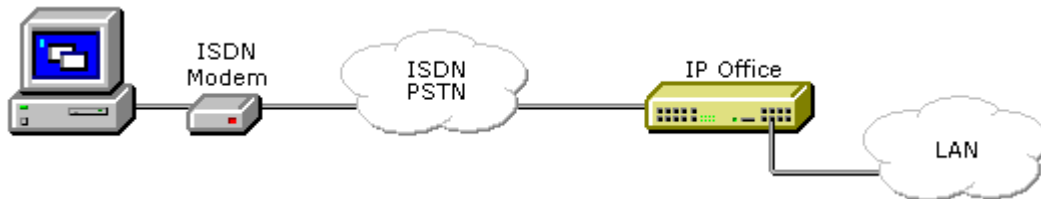

 **Create a User** The required details are:

- **In the User tab:** Enter a Name and Password. The system is case sensitive. Remember to take care with passwords as this is a remote access link into your network.
- **In the Dial In tab:** Ensure that Dial In On is ticked. The Firewall Profile and Time Profile are optional.

 **Create a RAS Record**

**In the RAS tab:** Enter the same name as the user that you created earlier. Again, remember this is case sensitive.

 **Create an Incoming Call Route**

- Set the **Bearer Capability** to **Any Data**.
- In the **Destination** drop-down list, select the RAS record created above.
- The values that you enter for any of the other fields will depend on whether the remote user will be calling in on a particular line, number or from a set ICLID.
  1. **Is a Return IP Route Needed ?** Go to Step 5.
  2.  **Create a IP Route (Optional)** If the remote user has an IP address that is not in the same domain as the system, then an IP Route is needed for return data. This is not

necessary if the remote user's dial-up connection method is set to 'Obtain an IP Address Automatically' and the system's **DHCP mode** is set to **Server** or **Dial In**.

- Enter the **IP Address** and **IP Mask** of the remote system.
- In the **Destination** drop-down list select the RAS record created above.

### Analog Remote Access Example

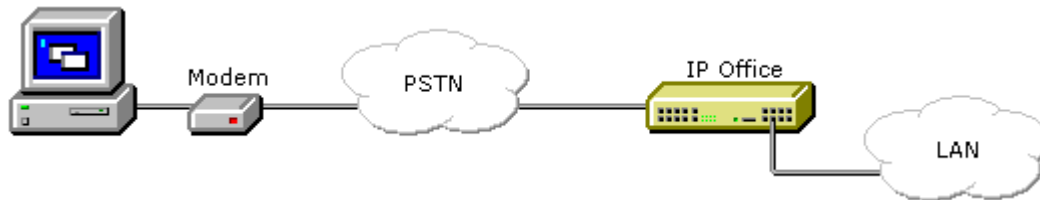

Configuration for a connection from an analog modem call is very similar to the ISDN example. However the system must be able to answer modem calls. This can be done in the following ways:

**Analog Trunk Modem Mode** On systems with an analog trunk card in the control unit, the first analog trunk can be set to answer V.32 modem calls. This is done by checking the Modem Enabled option on the analog line settings or using the default short code \*9000\* to toggle this service on or off.

**IP500 ATM4 Uni Trunk Card Modem Support** It is not required to switch the card's modem port on/off. The trunk card's V32 modem function can be accessed simply by routing a modem call to the RAS service's extension number. The modem call does not have to use the first analog trunk, instead the port remains available for voice calls.

When using an analog modem, the **Bearer Capability** of the incoming call route used should be **Any Voice**.

### Related links

[Overview of Data Routing](#) on page 1126

---

## Creating a VoIP Link via the WAN Port Using PPP

A VoIP link across a leased line requires the Control Unit at both ends to have a Voice Compression Module installed. These provide for a fixed number of channels to use VoIP at any time. They are used to compress voice down to either 6k3 (G.723) or 8k (G.729) and provide echo cancellation.

Both ends must using the same version of software and configured to use the same speed and compression.

For example, consider this VoIP link:

- Site A on IP address 192.168.42.1
- Site B on IP address 192.168.45.1

Perform the following steps, once for Site A and once for Site B.

1. **Create a Normal Service:** The Account Name and password is presented to the remote end, therefore must match the User name and password configured at Site B. The Encrypted Password option can only be used if the remote end also supports CHAP.
2. **Create a User:** Under the Dial In tab tick Dial In On. This User account is used to authenticate the connection from the Site B. As the Service and User have the same name these two configuration forms are automatically linked and become an Intranet Service. The User password is displayed at the bottom of the Service tab as the Incoming Password.
3. **Name:** SiteB
4. **Dial In | Dial In On:** Enabled.
5. **Create a RAS service:** If CHAP is to be used on this link, then the Encrypted Password option must be checked in the Service and in the RAS service. The name of the RAS service must match the name of the Service at Site B. If the RAS service is given the same name as the Service and User, they are automatically linked and become a WAN Service. Ensure that the Encrypted Password option is not checked when using a WAN Service.
6. **Edit the WANPort:** Note - do not create a new WANPort, this is automatically detected. If a WANPort is not displayed, connect the WAN cable, reboot the Control Unit and receive the configuration. The WANPort configuration form should now be added.

**RAS Name:** SiteA

7. **Create an IP Route:** The IP Address is the network address of the remote end. Under Destination select the Service created above.
8. **Create a new Line:** The Line Number and Line Group ID must be unique, in other words, not used by any other line. The Gateway IP Address is the IP Address of the Control Unit at the remote end. The Compression Mode used is dependent on the Voice Compression Card the Control Unit is running and the speed of the link.
9. **Create a Short Code:** To route all calls where the number dialed starts with 8 via Line Group ID 1, therefore via the VPN Line created above.
10. **Short Code:** 8N
11. **Telephone Number:** N
12. **Line Group ID:** 1
13. **Feature:** Dial

#### Related links

[Overview of Data Routing](#) on page 1126



# Chapter 23: Appendix: SMDR

The control unit is able to send SMDR (Station Message Detail Reporting) records to a specified IP address and port.

Typically an SMDR record is output for each call between two parties. In some scenarios, for examples transferred calls, multiple SMDR records are output for each part of the call. The different parts of the call are referred to as 'call legs' or 'call segments'.

Each SMDR call record is output in a CSV format with a comma between each field. See SMDR Record Format below for more detail.

## Enabling and Configuring SMDR

SMDR output is enabled as follows:

1. Access the system configuration using your preferred manager application.
2. Select **System** settings and then select the **SMDR** tab.
3. Use the **Output** drop down box to select **SMDR only** and enter the required **IP Address** and **TCP Port**.
4. Adjust any other SMDR output settings if required, see [System | SMDR](#) on page 264 for details.
5. For systems in a network of IP Offices, repeat this for all systems.

## Operation and SMDR Record Buffering

The system generates a record at the end of a call or each call leg. It attempts to send the record at the time it is generated. However, if not possible, it buffers records up to the limit set for the system (see [System | SMDR](#) on page 264). By default that is 500 records.

- Whilst buffering, it still attempts to send a record when that new record is generated. If successful, it will also send any buffered records.
- If the buffer limit is reached, the system deletes the oldest record each time a new record is added. The buffer is maintained through system restarts.

## Checking SMDR Generation

Having enabled SMDR output, the generation of records can be view by enabling the **Call** trace options **Call Detail Records** and **CDR Extra Diagnostics** in System Monitor. Note that this causes any records displayed to be removed from the buffer.

## SMDR Record Output

An SMDR record is generated at the end of each call between two devices on the system. Devices include extensions, trunk lines (or channels on a trunk), voicemail channels, conference channels and system tones.

- SMDR records are only produced for calls which are presented to another device or a barred short code. For example, an internal user dialing a short code that simply changes a setting does not produce a SMDR record.
- SMDR records are generated when each call or call leg ends. Therefore the output order of the SMDR records does not match the call start times.
- Each record contains a **Call ID** :
  - The **Call ID** starts from 1,000,000 and is reset back to that value following each system restart.
  - The **Call ID** is increased by 1 for each subsequent new call.
  - When a call moves from one device to another, separate SMDR records are output each part of the call. Each of these records has the same **Call ID**.
  - Each record indicates in its **Continuation** field whether there are further records for the same call.

## SMDR Record Format

The format used for the SMDR record output is:

- Each SMDR record contains call information in a comma-separated format (CSV), that is a byte stream of variable width fields delimited by commas (0x2C).
- Each record is terminated by carriage-return (0x0D), newline (0x0A) sequence. There is no quoting or escaping currently defined as fields do not include ',' or 'newline' characters.

## Call Times

Each SMDR record can include values for ringing time, connected time, held time and parked time. The total duration of an SMDR record is the sum of those values.

- The time when a call is not in one of the states above, is not included in the SMDR record.
- All times are rounded up to the nearest second.
- Where announcements are being used, the connected time for a call begins either when the call is answered or the first announcement begins.
- Each SMDR record has a **Call Start Time** taken from the system time. For calls being transferred or subject to call splitting, each of the multiple SMDR records for the call has the same **Call Start** time as the original call.
- The **UTC Time** shown at the end of the record is the time at which the SMDR record was generated.

## Related links

[SMDR Fields](#) on page 1139

[SMDR Examples](#) on page 1142

---

## SMDR Fields

The SMDR output contains the following fields. Note that time values are rounded up to the nearest second.

1. **Call Start Time** – The call start time in the format YYYY/MM/DD HH:MM:SS. This is based on the system time including any DST offset.
  - All records relating to the same call, that is having the same **Call ID**, have the same **Call Start Time**.
  - If the system has **Call Splitting for Diverts** enabled, the **Call Start Time** is changed to the time the forward occurred for all records following that stage of the call. However, the records for the externally forwarded call retain the original **Call ID**.
2. **Connected Time** – Duration of the connected part of the call in HH:MM:SS format. This does not include ringing, held and parked time. A lost or failed call will have a duration of 00:00:00. The total duration of a record is calculated as **Connected Time + Ring Time + Hold Time + Park Time**.
3. **Ring Time** – Duration of the ring part of the call in seconds.
  - For inbound calls, this represents the interval between the call arriving at the switch and it being answered. It does not match the time a call rang at an individual extension.
  - For outbound calls, this indicates the interval between the call being initiated and being answered at the remote end if supported by the trunk type. Analog trunks are not able to detect remote answer and therefore cannot provide a ring duration for outbound calls.
4. **Caller** – The caller's number. If the call originated at an extension, this is the extension number. If the call originated externally, this is the CLI of the caller if available, otherwise blank. For SIP trunks, the field can contain the number plus IP address. For example, 12345@192.0.2.123.
5. **Direction** – The direction of the call ; **I** for inbound, **O** for outbound. This value can be used in conjunction with the **Is Internal** value below to determine the call type.
6. **Called Number** – This is the number called by the system. For a call that is transferred, this field shows the original called number, not the number of the party who transferred the call.
  - **Internal calls** – The extension, group or short code called
  - **Inbound calls** – The target extension number for the call
  - **Outbound calls** – The dialed digits
  - **Voice Mail** – Calls to a user's own voicemail mailbox
7. **Dialled Number** – For internal calls and outbound calls, this is identical to the **Called Number** above. For inbound calls, this is the DDI of the incoming caller.
8. **Account Code** – The last account code attached to the call.
9. **Is Internal** – This field indicates whether both parties on the call are internal (**1**) or not (**0**). Note that calls to destinations on other switches in a network are treated as internal. This

value can be used in conjunction with the **Direction** value above to determine the call type as follows:

Direction	Is Internal	Call Type
I	0	Incoming external call.
O	1	Internal call.
O	0	Outgoing external call.

10. **Call ID** – This is a numerical identifier, which is incremented for each unique call. If the call has generates several SMDR records, each record has the same **Call ID**. Note that the Call ID is restarted from 1,000,000 following any system restart.
11. **Continuation** – This value indicates if the call has any further records with the same **Call ID**. It is **1** if there is a further record, otherwise **0**.
12. **Party1 Device** – The device 1 number. This is usually the call initiator though in some scenarios, such as conferences, this may vary. If an extension/hunt group is involved in the call, its details have priority over any trunk. That includes remote network destinations.

Type	Party Device	Party Name
<b>Internal Number</b>	<b>E</b> <extension number>	<name>
<b>Voicemail</b>	<b>V</b> <9500 + channel number>	<b>VM Channel</b> <channel number>
<b>Conference</b>	<b>V</b> <1><conference number> <+channel number>	<b>CO Channel</b> <conference number.channel number>
<b>Line</b>	<b>T</b> <9000+line number>	<b>Line</b> <line number>.<channel if applicable>
<b>Other</b>	<b>V</b> <8000+device number>	<b>U</b> <device class> <device number>.<device channel>
<b>Unknown/Tone</b>	<b>V8000</b>	<b>U1 0.0</b>

13. **Party1 Name** – The name of the device. For an extension or agent, this is the user name encoded in UTF-8.
14. **Party2 Device** – The other party for the call segment. Encoded as per **Party1 Device** above. For barred calls, this field shows **Barred**.
15. **Party2 Name** – The other parties name. See **Party1 Name** above. For barred calls, this field shows **Barred**.
16. **Hold Time** – The number of seconds the call has been held during this call segment.
17. **Park Time** – The number of seconds the call has been parked during this call segment.
18. **Authorization Valid** – This field is used for authorization codes. This field shows **1** for valid authorization or **0** for invalid authorization. This is Blank, no code is used.
19. **Authorization Code** – For security, this field shows **n/a** regardless of the authorization code used. This is blank, no code is used.
20. **User Charged** – This and fields 21 to 27 are used for ISDN Advice of Charge (AoC). If blank, AoC is not being used. This field indicates the user to which the call charge has been assigned. This is not necessarily the user involved in the call.

21. **Call Charge** – The total call charge calculated using the line cost per unit and user markup.
22. **Currency** – The currency. This is a system wide setting set in the system configuration.
23. **Amount at Last User Change** – The current AoC amount at user change.
24. **Call Units** – The total call units.
25. **Units at Last User Change** – The current AoC units at user change.
26. **Cost per Unit** – This value is set in the system configuration against each line on which AoC signalling is set. The values are 1/10,000th of a currency unit. For example, if the call cost per unit is £1.07, a value of 10700 should be set on the line.
27. **Mark Up** – Indicates the mark up value set in the system configuration for the user to which the call is being charged. The field is in units of 1/100th, for example an entry of 100 is a markup factor of 1 .
28. **External Targeting Cause** – This field indicates who or what caused the external call and a reason code. For example **U FU** indicates that the external call was caused by the Forward Unconditional settings of a User.

Targeted by		Reason Code	
<b>HG</b>	Hunt Group.	<b>fb</b>	Forward on Busy.
<b>U</b>	User.	<b>fu</b>	Forward unconditional.
<b>LINE</b>	Line.	<b>fnr</b>	Forward on No Response.
<b>AA</b>	Auto Attendant.	<b>fdnd</b>	Forward on DND.
<b>ICR</b>	Incoming Call Route.	<b>CfP</b>	Conference proposal (consultation) call.
<b>RAS</b>	Remote Access Service.	<b>Cfd</b>	Conferenced.
<b>?</b>	Other.	<b>MT</b>	Mobile Twinning.
		<b>TW</b>	Teleworker.
		<b>XfP</b>	Transfer proposal (consultation) call.
		<b>Xfd</b>	Transferred call.

29. **External Targeter ID** – The associated name of the targeter indicated in the **External Targeting Cause** field.
  - For hunt groups and users, this is their name in the system configuration.
  - For an incoming call route, this is the route's **Tag** value if set, otherwise **ICR**.
30. **External Targeted Number** – This field is used for forwarded, Incoming Call Route targeted and mobile twin calls to an external line. It shows the external number called by the system as a result of the off-switch targeting whereas other called fields give the original number dialled.
31. **Calling Party Server IP Address** – This IP address identifies the server where the calling extension is logged in.

32. **Unique Call ID for the Caller Extension** – Numerical value that is a unique identifier of the call on the server where the call was initiated.
33. **Called Party Server IP Address** – This IP address identifies the server where the called extension is logged in. If the field does not contain an IP address, then the call is to a trunk outside the IP Office network.
34. **Unique Call ID for the Called Extension** – Numerical value that is a unique identifier of the call on the server where the called extension is logged in.
35. **SMDR Record Time** – The system date and time, not including any DST offset, at which the SMDR record was generated. It uses the format YYYY/MM/DD HH:MM:SS.
36. **Caller Consent Directive** – This field is used for calls going through an auto-attendant service that is configured to ask for caller consent to some choice.
  - 0 = Consent Not Requested
  - 2 = Consent Given
  - 6 = Consent Denied

#### Related links

[Appendix: SMDR](#) on page 1137

---

## SMDR Examples

The following are examples of system SMDR records for common call scenarios.

In the following examples, the underlined fields indicate key values in the interpretation of the scenario. ... is used to indicate that further fields have been omitted for clarity as they are not relevant to the example.

### Lost incoming Call

In this record, the **Connected Time** is zero and the **Continuation** field is 0, indicating that the call was never connected. The **Ring Time** shows that it rang for 9 seconds before ending.

```
2014/06/28 09:28:41,00:00:00,9,8004206,I,4324,4324,,0,1000014155,0,E4324,Joe  
Bloggs,T9161,LINE 5.1,0,0,...
```

### Call Answered by Voicemail

In this example, 215 has made a call to 211. However, the **Party2Device** and **Party2Name** fields show that the call was answered by voicemail.

```
2014/10/20 06:43:58,00:00:10,21,215,0,211,211,,I,28,0,E215,Extn215,V9051,VM Channel  
1,0,0,...
```

## Call Transferred to Voicemail

In this example, the **Continuation** field being 1 in the first record tells us that it was not the end of the call. The matching **Call ID** identifies the second record as part of the same call. The change in **Party 1** details between the two records show that the call was transferred to voicemail.

```
2014/06/28 09:30:57,00:00:13,7,01707392200,I,299999,299999,,0,1000014160,1,E4750,John
Smith,T9002,LINE 1.2,11,0,...
```

```
2014/06/28 09:30:57,00:00:21,0,01707392200,I,299999,299999,,0,1000014160,0,V9502,VM
Channel 2,T9002,LINE 1.2,0,0,...
```

## External Call

The **Is Internal** field being 0 indicates that this is an external call. The **Direction** field being I shows that it was an incoming call. The **Ring Time** was 7 seconds and the total **Connected Time** was 5 seconds.

```
2014/08/01
15:14:19,00:00:05,7,01707299900,I,403,390664,,0,1000013,0,E403,Extn403,T9001,Line
1.2,0,0,...
```

## Internal Call

The **Is Internal** field being 1 indicates that this is an internal call. The **Ring Time** was 4 seconds and the **Connected Time** was 44 seconds.

```
2014/06/26 10:27:44,00:00:44,4,4688,0,4207,4207,,1,1000013898,0,E4688,Joe
Bloggs,E4207,John Smith,0,0,...
```

## Outgoing Call

The combination of the **Direction** field being outbound and the **Is Internal** field being 0 show that this was a outgoing external call. The line (and in this case channel) used are indicated by the **Party2 Name** and being a digital channel the **Ring Time** before the call was answered is also shown.

```
2014/06/28 08:55:02,00:08:51,9,4797,Q,08000123456,08000123456,,0,1000014129,0,E4797,Joe
Bloggs,T9001,LINE 1.1,0,0,...
```

## Voicemail Call

The two records below show calls to voicemail. The first shows the **Dialed Number** as \*17, the default short code for voicemail access. The second shows the **Dialed Number** as **VoiceMail**, indicating some other method such as the **Message** key on a phone was used to initiate the call.

```
2014/06/28 09:06:03,00:00:19,0,4966,0,*17,*17,,1,1000014131,0,E4966,John Smith,V9501,VM
Channel 1,0,0,...
```

```
2014/06/28 09:06:03,00:00:19,0,4966,0,VoiceMail,VoiceMail,,1,1000014134,0,E4966,John
Smith,V9501,VM Channel 1,0,0,...
```

## Parked Call

In this example the first record has a **Park Time** showing that the call was parked for 7 seconds. The **Continuation** field indicates that the call did not end yet and there are further records. The second record has the same **Call ID** and shows a change in the **Party2Name**, indicating that another party unparked the call. Note also that both records share the same call start time.

```
2014/10/20
07:18:31,00:00:12,3,215,0,210,210,,1,1000038,1,E215,Extn215,E210,Extn210,0,7,...
```

```
2014/10/20
07:18:31,00:00:10,0,215,0,210,210,,1,1000038,0,E215,Extn215,E211,Extn211,0,0,...
```

## Incoming call with Account Code

In this example, at some stage as the call was made or during the call, an Account Code has been entered. During a call, another account code can be entered. The SMDR record shows the last account code used before the record was generated.

```
2014/06/28
11:29:12,00:00:02,2,5002,I,1924,1924,123456789,0,1000014169,0,E1924,Extn1924,T9620,LINE
8.20,0,0,...
```

## Conference Using Conference Add Short Code

In this example, a user conferences 2 calls. This creates 5 SMDR records; 2 initial 2-party calls and then 3 calls connected to a system's conference.

First 2101 has made a call and put it on hold (record 2), then made another call and put it on hold (record 1) and then dialed the default short code \*47 to conference their held calls (record 3). The records for the first two calls have the **Continuation** field set as 1 indicating that the calls continued in further records.

Record 3 shows 2101 making a new call in which they dial \*47, which places them and their held calls into a conference. This is shown by the **Party 2 Device** and **Party 2 Name** details as being a conference (100) and the conference channel used for each.

```
2014/07/09
17:55,00:00:03,3,2101,0,8262623#,8262623#,,0,1000024,1,E2101,Extn2101,T9002,Line
2.1,8,0,...
```

```
2014/07/09
17:54,00:00:29,7,2101,0,2121,2121,,1,1000023,1,E2101,Extn2101,E2121,Extn2121,23,0,...
```

```
2014/07/09 17:55,00:00:46,0,2101,0,*47,*47,,1,1000026,0,E2101,Extn2101,V11001,CO
Channel 100.1,0,0,...
```

```
2014/07/09
17:54,00:00:49,0,,0,71234567890,71234567890,,1,1000023,0,E2121,Extn2121,V11003,CO
Channel 100.3,0,0,...
```

```
2014/07/09 17:55,00:00:49,0,,0,8262623#,8262623#,,0,1000024,0,V11002,CO Channel
100.2,T9002,Line 2.1,0,0,...
```

## Conference Using Conference Button

In this example, an extension user answers a call and then brings in another user by using the **Conference** button on their phone. Again we see records for the initial call, the conference proposal call and then for the 3 parties in the conference that is created.

```
2014/07/09
15:05:41,00:00:04,3,203,0,201,201,,1,1000009,1,E203,Extn203,E201,Extn201,0,0,...
```

```
2014/07/09
15:05:26,00:00:09,3,207,0,203,203,,1,1000008,1,E207,Extn207,E203,Extn203,10,0,...
```

```
2014/07/09 15:05:41,00:00:08,0,,0,,1,1000009,0,E201,Extn201,V11001,CO Channel
100.1,0,0,...
```

```
2014/07/09 15:05:50,00:00:10,0,203,0,201,201,,1,1000010,0,E203,Extn203,V11002,CO
Channel 100.2,0,0,...
```

```
2014/07/09 15:05:26,00:00:10,0,207,0,203,203,,1,1000008,0,E207,Extn207,V11003,CO
Channel 100.3,0,0,...
```



## Adding a Party to a Conference

This example is a variant on that above. Having started a conference, extension 203 adds another party.

```
2014/07/09
15:08:31,00:00:03,3,203,O,201,201,,1,1000014,1,E203,Extn203,E201,Extn201,0,0,...
```

```
2014/07/09
15:08:02,00:00:22,6,207,O,203,203,,1,1000013,1,E207,Extn207,E203,Extn203,9,0,...
```

```
2014/07/09 15:08:45,00:00:02,4,203,O,403,403,,0,1000016,1,E203,Extn203,E403,Libby
Franks,0,0,...
```

```
2014/07/09 15:08:02,00:00:24,0,207,O,203,203,,1,1000013,0,E207,Extn207,V11003,CO
Channel 100.3,0,0,...
```

```
2014/07/09 15:08:39,00:00:17,0,203,O,201,201,,1,1000015,0,E203,Extn203,V11002,CO
Channel 100.2,8,0,...
```

```
2014/07/09 15:08:31,00:00:26,0,,O,,,1,1000014,0,E201,Extn201,V11001,CO Channel
100.1,0,0,...
```

```
2014/07/09 15:08:45,00:00:12,0,,O,403,403,,0,1000016,0,E403,Libby Franks,V11004,CO
Channel 100.4,0,0,...
```

## Transfer

In this example, 2126 has called 2102. The 1st record has the **Continuation** set a 1, indicating that it the call has further records. The 3rd record has the same **Call ID** but the **Party 2 Device** and **Party 2 Name** fields have changed, indicating that the call is now connected to a different device. We can infer the blind transfer from the 2nd record which shows a call of zero **Connected Time** between the original call destination 2102 and the final destination 2121.

```
2014/07/09
17:51,00:00:38,18,2126,O,2102,2102,,1,1000019,1,E2126,Extn2126,E2102,Extn2102,19,0,...
```

```
2014/07/09
17:52,00:00:00,7,2102,O,2121,2121,,1,1000020,0,E2102,Extn2102,E2121,Extn2121,0,0,...
```

```
2014/07/09
17:51,00:00:39,16,2126,O,2102,2102,,1,1000019,0,E2126,Extn2126,E2121,Extn2121,0,0,...
```

In this second example, extension 402 answers an external call and then transfers it to extension 403. Again the two legs of the external call have the same time/date stamp and same call ID.

```
2014/08/01
15:23:37,00:00:04,7,01707299900,I,4001,390664,,0,1000019,1,E402,Extn402,T9001,Line
1.1,6,0,...
```

```
2014/08/01
15:23:46,00:00:00,3,402,O,403,403,,1,1000020,0,E402,Extn402,E403,Extn403,0,0,...
```

```
2014/08/01
15:23:37,00:00:04,4,01707299900,I,4001,390664,,0,1000019,0,E403,Extn403,T9001,Line
1.1,0,0,...
```

## Busy/Number Unavailable Tone

In this example, 2122 calls 2123 who is set to DND without voicemail. This results in 2122 receiving busy tone.

The records shows a call with a **Connected Time** of 0. The **Call Number** field shows 2123 as the call target but the **Party 2 Device** and **Party 2 Name** fields show that the connection is to a virtual device that is generating the audio tone.

```
2014/07/09 17:59:00:00:00,0,2122,0,2123,2123,,1,1000033,0,E2122,Extn2122,V8000,U1
0.0,0,0,...
```

### Call Pickup

The first record shows a call from 2122 to 2124 with a **Connected Time** of zero but a **Ring Time** of 8. The **Continuation** field indicates that the call has further records.

The second record has the same **Call ID** but the **Party 2 Device** and **Party 2 Name** details show that the call has been answered by 2121.

```
2014/07/09
18:00,00:00:00,8,2122,0,2124,2124,,1,1000038,1,E2122,Extn2122,E2124,Extn2124,0,0,...
```

```
2014/07/09
18:00,00:00:38,1,2122,0,2124,2124,,1,1000038,0,E2122,Extn2122,E2121,Extn2121,0,0,...
```

### Internal Twinning

The records for scenarios such as internal call forwarding or follow me indicate the rerouting in a single record by having **Caller** and **Called Number** details that differ from the final **Party 1** and **Party 2** details. Internal twinning differs is showing a call answered at the twin exactly the same as having been answered at the primary.

203 is internally twinned to 201. Call from 207 to 203 but answer at 201.

```
2014/07/09
16:25:26,00:00:03,7,207,0,203,203,,1,1000037,0,E207,Extn207,E203,Extn203,0,0,...
```

### Park and Unpark

Parking and unparking of a call at the same extension is simply shown by the **Park Time** field of the SMDR record. Similarly, calls held and unheld at the same extension are shown by the **Held Time** field of the SMDR record for the call. The records below however, show a call parked at one extension and then unparked at another.

The records show a call from 207 to 203. 203 then parks the call shown by the **Park Time**. The call is unparked by 201, hence the first record is indicated as continued in its **Continuation** field. The matching **Call ID** indicates the subsequent record for the call.

```
2014/07/09
16:39:11,00:00:00,2,207,0,203,203,,1,1000052,1,E207,Extn207,E203,Extn203,0,4,...
```

```
2014/07/09
16:39:11,00:00:02,0,207,0,203,203,,1,1000052,0,E207,Extn207,E201,Extn201,0,0,...
```

## Distributed Hunt Group Call

An incoming call to site A is targeted to a distributed hunt group member on site B. They transfer the call back to a hunt group member on site A.

```
2014/08/01
15:32:52,00:00:10,19,01707299900,I,4002,390664,,0,1000024,1,E209,Luther-209,T9001,Line
1.2,0,0,...
```

```
2014/08/01
15:33:19,00:00:00,2,209,I,403,403,,0,1000025,0,E209,Luther-209,E403,Extn403,0,0,...
```

```
2014/08/01
15:32:52,00:00:03,3,01707299900,I,4002,390664,,0,1000024,0,E403,Extn403,T9001,Line
1.2,0,0,...
```

## Voicemail Supervised Transfer

A call is routed to a voicemail module that performs a supervised transfer.

```
2014/08/01 16:36:04,00:00:09,0,01707299900,I,xfer,390664,,0,1000061,1,T9001,Line
1.1,V9508,VM Channel 8,0,0,...
```

```
2014/08/01 16:36:07,00:00:03,4,,I,402,402,,0,1000062,0,E402,Extn402,V8000,U12
0.8,0,0,...
```

```
2014/08/01
16:36:04,00:00:09,0,01707299900,I,402,390664,,0,1000061,0,E402,Extn402,T9001,Line
1.1,0,0,...
```

## Outgoing External Call

The **External Targeting Cause** indicates that the external call was caused by a user. The lack of specific reason implies that it was most likely dialed. The **External Targeter ID** is the user name in this example

```
2014/08/01 16:23:06,00:00:04,5,203,0,9416,9416,,0,1000035,0,E203,Extn203,T9005,Line
5.1,0,0,,Extn203,,,,,,,,U,Extn203,...
```

## Rerouted External Call

In this example, an incoming external call has been rerouted back off switch, shown by the **Party 1** fields and the **Party 2** fields being external line details. The **External Targeter Cause** shows that rerouting of the incoming call was done by an incoming call route (ICR). The **External Targeter ID** in this case is the **Tag** set on the incoming call route. The **External Targeted Number** is the actual external number call.

```
2014/08/01 08:14:27,00:00:03,5,392200,I,9416,200,,0,1000073,0,T9005,Line 5.1,T9005,Line
5.2,0,0,,0000.00,,0000.00,0,0,618,0.01,ICR,Main ICR,416,...
```

## External Forward Unconditional

In this example, user 203 has a forward unconditional number set for calls. This is indicated by the **External Targeting Cause** showing user and forward unconditional. The **External Targeter ID** shows the source of the call being forwarded, in this example user 207. The **External Targeted Number** shows the actual external number called by the system.

```
2014/08/01 16:22:41,00:00:02,5,207,0,203,203,,0,1000034,0,E207,Extn207,T9005,Line
5.1,0,0,,Extn203,0000.00,,0000.00,0,0,618,1.00,U_fu,Extn207,9416,...
```

## Transferred Manually

In this example the internal user transfers a call to an external number. The **External Targeting Cause** in the first record indicates that this external call is the result of a user (U) transfer proposal

(XfP) call. The **Continuation** field indicates that another record with the same **Call ID** will be output.

The additional records are output after the transferred call is completed. The first relates to the initial call prior. The second is the transferred call with the **External Targeting Cause** now indicating user (U) transferred (Xfd).

```
2014/08/01 16:33:19,00:00:05,3,203,0,9416,9416,,0,1000044,1,E203,Extn203,T9005,Line
5.1,0,0,,,,,,,,,U XfP,Extn207,...
```

```
2014/08/01
16:33:09,00:00:02,2,207,0,203,203,,1,1000043,0,E207,Extn207,E203,Extn203,11,0,...
```

```
2014/08/01 16:33:19,00:00:04,0,207,0,9416,9416,,0,1000044,0,E207,Extn207,T9005,Line
5.1,0,0,,,Extn207,,,,,,,,,U Xfd,Extn203,...
```

### Mobile Twinned Call Answered Internally

For this example, user 203 has mobile twinning enabled to the external number 9416 as their twin. Their mobile dial delay is set to 2 seconds. The call is answered at the user's internal extension.

In this scenario the record for the external call part of twinning is output immediately the call is answered internally. The **Call Start Time** for this record differs due to the user's **Mobile Dial Delay** setting. The **External Targeting Cause** indicates the external call was the result of user (U) mobile twinning (MT) settings. If the call had been answered before the mobile dial delay expired, no external call and therefore no record would be produced. When the call is completed the second record is output.

```
2014/08/01 16:17:59,00:00:00,7,,0,9416,9416,,0,1000028,0,E203,Extn203,T9005,Line
5.1,0,0,,,,,,,,,U MT,Extn203,9416,...
```

```
2014/08/01
16:17:58,00:00:07,9,207,0,203,203,,1,1000027,0,E207,Extn207,E203,Extn203,0,0,...
```

### Mobile Twinned Call Answered at the Mobile Twin

This is the same scenario as the example above except that the call is answered at the external mobile twinning destination. Unlike the previous example, the external call record has a non-zero **Connected Time**, showing that the call was also answered externally.

```
2014/08/01 16:17:04,00:00:06,9,,0,9416,9416,,0,1000026,0,E203,Extn203,T9005,Line
5.1,0,0,,,,,,,,,U MT,Extn203,9416,...
```

```
2014/08/01
16:17:02,00:00:06,11,207,0,203,203,,1,1000025,0,E207,Extn207,E203,Extn203,0,0,...
```

### Mobile Twinned Call Picked Up Using the Twinning Button

This is the same scenario as the example above, however after answering the call on the external twinned device, the user has picked it up internally by using a twinning button. The first two records are for the answered external call and are output when that call is picked up by the internal extension. The third record is output when the call is ended internally.

```
2014/08/01
16:19:18,00:00:05,11,207,0,203,203,,1,1000029,1,E207,Extn207,E203,Extn203,0,0,...
```

```
2014/08/01 16:19:20,00:00:05,9,,0,9416,9416,,0,1000030,0,E203,Extn203,T9005,Line
5.1,0,0,,,,,,,,,U MT,Extn203,9416,...
```

```
2014/08/01
16:19:18,00:00:05,0,207,0,203,203,,1,1000029,0,E207,Extn207,E203,Extn203,0,0,...
```

### External Conference Party

This is similar to internal conferencing (see examples above) but the conference setup and progress records include **External Targeting Cause** codes for user (**U**) conference proposal (**CfP**) and user (**U**) conferenced (**Cfd**).

```
2014/08/01 16:48:58,00:00:02,2,203,O,9416,9416,,0,1000066,1,E203,Extn203,T9005,Line
5.1,0,0,,,,,,,,,U CfP,Extn203,...
```

```
2014/08/01
16:48:37,00:00:04,3,203,O,207,207,,1,1000064,1,E203,Extn203,E207,Extn207,7,0,...
```

```
2014/08/01 16:49:04,00:00:08,0,203,O,9416,9416,,1,1000067,0,E203,Extn203,V11002,CO
Channel 100.2,0,0,...
```

```
2014/08/01 16:48:37,00:00:13,0,,O,,,,1,1000064,0,E207,Extn207,V11003,CO Channel
100.3,0,0,...
```

```
2014/08/01 16:48:58,00:00:13,0,,O,9416,9416,,0,1000066,0,V11001,CO Channel
100.1,T9005,Line 5.1,0,0,,,,,Extn203,,,,,U Cfd,Extn203,...
```

### Call Routed by Incoming Call Route

Call from external number 403 rerouted by incoming call route (ICR) for incoming line group 701 back out to 404.

```
2014/08/01 11:45:36,00:00:01,2,403,I,9404,,0,1000007,0,T9001,Line 1.0,T9010,Line
10.0,0,0,0,n/a,,,,,ICR,ICR701,404,...
```

### Two Outgoing External Calls Transferred Together

This scenario shows an outgoing call which is then transferred to another outgoing call.

```
2009/02/19 11:13:26,00:00:06,0,203,O,9403,9403,,0,1000012,1,E203,Extn203,T9001,Line
1.0,8,0,0,n/a,,,,,U,Extn203,...
```

```
2009/02/19 11:13:36,00:00:02,0,203,O,8404,8404,,0,1000013,0,E203,Extn203,T9002,Line
2.0,0,0,0,n/a,,,,,U XfP,Extn203,...
```

```
2009/02/19 11:13:26,00:00:11,0,8404,I,404,,0,1000012,0,T9002,Line 2.0,T9001,Line
1.0,0,0,0,n/a,,,,,LINE Xfd,0.1038.0 13 Alog Trunk:2,...
```

### Authorization code

In this example, an authorization code was used and the 0 indicates that it is invalid.

```
2014/02/20 11:04:59,00:00:00,0,319,O,,,,0,1000009,0,E319,Alice,V8000,U1 0.0,0,0,0,n/
a,,,,,U,Alice,...
```

In this example, the authorization code is valid.

```
2014/02/20 11:04:59,00:00:00,0,319,O,,,,0,1000009,0,E319,Alice,V8000,U1 0.0,0,0,1,n/
a,,,,,U,Alice,...
```

### Internal Network Call

The SMDR records include fields (31 to 34) that identifying the calling and called IP Office systems. These are useful for calls between systems in an IP Office network. This still requires each system in the network to be configured to output its own SMDR records..

In this example, 806 on the 1st IP Office system (192.168.0.182) makes an internal call to 706 on the 2nd IP Office system (192.168.0.180). Both systems output their own SMDR record for the same call.

- **Record from 1st IP Office system with the calling extension 806:**

```
2020/03/06
10:33:27,00:00:15,8,806,I,706,706,,1,1000018,0,E806,Extn806,E706,Extn706,7,0,,,,,,,,,
```

```

,,,,,,192.168.0.182,1049,192.168.0.180,1087,
2020/03/06 10:33:56,0

```

- **Record from 2nd IP Office system with the called extension 706:**

```

2020/03/06
10:33:27,00:00:22,8,806,0,706,706,,1,1000004,0,E806,Extn806,E706,Extn706,0,0,,,,,,
,,,,,,192.168.0.182,1049,192.168.0.180,1087,
2020/03/06 10:33:56,0

```

## Caller Consent Request

The actions in Embedded Voicemail auto-attendants and Voicemail Pro call flows can be assigned a consent setting value. By selecting the particular action the caller can indicate their consent. That value is indicated in the SMDR record for the call.

- **Consent Not Requested** – In this example, the call action used to route the call does not have a consent setting. Therefore, the consent setting within the SMDR record remains 0.

```

2020/03/06 10:35:42,00:00:02,0,201,0,*99,*99,,1,1000000,1,E201,Extn201,V9511,VM
Channel 11,0,0,,,,,,192.168.0.1,1002,192.168.0.1,1004,
2020/03/06 10:35:45,0
2020/03/06
10:35:42,00:00:02,2,201,0,*99,*99,,1,1000000,0,E201,Extn201,E202,Extn202,0,0,,,,,,
,,,,,,192.168.0.1,1002,192.168.0.1,1005,
2020/03/06 10:35:49,0

```

- **Consent Denied** – In this example, the call action used to route the call is set to indicate consent denied. Therefore, the consent setting in the SMDR record is changed to 6.

```

2020/03/06 10:35:54,00:00:02,0,201,0,*99,*99,,1,1000001,1,E201,Extn201,V9511,VM
Channel 11,0,0,,,,,,192.168.0.1,1007,192.168.0.1,1009,
2020/03/06 10:35:56,6
2020/03/06
10:35:54,00:00:01,4,201,0,*99,*99,,1,1000001,0,E201,Extn201,E202,Extn202,0,0,,,,,,
,,,,,,192.168.0.1,1007,192.168.0.1,1010,
2020/03/06 10:36:00,6

```

- **Consent Given** – In this example, the consent action used to route the call is set to indicate consent accepted. Therefore, the consent setting in the SMDR record is changed to 2.

```

2020/03/06 10:36:08,00:00:02,0,201,0,*99,*99,,1,1000003,1,E201,Extn201,V9511,VM
Channel 11,0,0,,,,,,192.168.0.1,1014,192.168.0.1,1016,
2020/03/06 10:36:09,2
2020/03/06
10:36:08,00:00:01,1,201,0,*99,*99,,1,1000003,0,E201,Extn201,E202,Extn202,0,0,,,,,,
,,,,,,192.168.0.1,1014,192.168.0.1,1017,
2020/03/06 10:36:11,2

```

## Related links

[Appendix: SMDR](#) on page 1137

# Chapter 24: Resources

---

## Documentation resources

For a listing of documentation resources related to IP Office,

- Download documents from the Avaya Support website at <http://support.avaya.com>.
- IP Office documentation is also available on the IP Office Knowledgebase at <https://ipofficekb.avaya.com>.

### Related links

[Finding documents on the Avaya Support website](#) on page 1151

---

## Finding documents on the Avaya Support website

### Procedure

1. Go to <https://support.avaya.com>.
2. At the top of the screen, type your username and password and click **Login**.
3. Click **Support by Product > Documents**.
4. In **Enter your Product Here**, type the product name and then select the product from the list.
5. In **Choose Release**, select the appropriate release number.

The **Choose Release** field is not available if there is only one release for the product.

6. In the **Content Type** filter, click a document type, or click **Select All** to see a list of all available documents.

For example, for user guides, click **User Guides** in the **Content Type** filter. The list only displays the documents for the selected category.

7. Click **Enter**.

### Related links

[Documentation resources](#) on page 1151

---

## Support

Visit the Avaya Support website at <http://support.avaya.com> for the most up-to-date documentation, product notices, and knowledge articles. You can also search for release notes, downloads, and resolutions to issues. Use the online service request system to create a service request. Chat with live agents to get answers to questions, or request an agent to connect you to a support team if an issue requires additional expertise.

For questions regarding IP Office documentation, send an email to [infodev@avaya.com](mailto:infodev@avaya.com).

---

## Using the Avaya InSite Knowledge Base

The Avaya InSite Knowledge Base is a web-based search engine that provides:

- Up-to-date troubleshooting procedures and technical tips
- Information about service packs
- Access to customer and technical documentation
- Information about training and certification programs
- Links to other pertinent information

If you are an authorized Avaya Partner or a current Avaya customer with a support contract, you can access the Knowledge Base without extra cost. You must have a login account and a valid Sold-To number.

Use the Avaya InSite Knowledge Base for any potential solutions to problems.

1. Go to <http://www.avaya.com/support>.
2. Log on to the Avaya website with a valid Avaya user ID and password.  
The system displays the Avaya Support page.
3. Click **Support by Product > Product-specific Support**.
4. In **Enter Product Name**, enter the product, and press `Enter`.
5. Select the product from the list, and select a release.
6. Click the **Technical Solutions** tab to see articles.
7. Select relevant articles.

---

## Viewing Avaya Mentor videos

Avaya Mentor videos provide technical content on how to install, configure, and troubleshoot Avaya products.



## About this task

Videos are available on the Avaya Support website, listed under the video document type, and on the Avaya-run channel on YouTube.

- To find videos on the Avaya Support website, go to <https://support.avaya.com/> and do one of the following:
  - In **Search**, type `Avaya Mentor Videos`, click **Clear All** and select **Video** in the **Content Type**.
  - In **Search**, type the product name. On the Search Results page, click **Clear All** and select **Video** in the **Content Type**.

The **Video** content type is displayed only when videos are available for that product.

In the right pane, the page displays a list of available videos.

- To find the Avaya Mentor videos on YouTube, go to [www.youtube.com/AvayaMentor](http://www.youtube.com/AvayaMentor) and do one of the following:
  - Enter a key word or key words in the **Search Channel** to search for a specific product or topic.
  - Scroll down Playlists, and click a topic name to see the list of videos available for the topic. For example, Contact Centers.

 **Note:**

Videos are not available for all products.

---

## Additional IP Office resources

You can find information at the following additional resource websites.

### Avaya

<https://www.avaya.com> is the official Avaya website. The front page also provides access to individual Avaya websites for different countries.

### Avaya Sales & Partner Portal

<https://sales.avaya.com> is the official website for all Avaya Business Partners. The site requires registration for a user name and password. Once accessed, the portal can be customized for specific products and information types that you wish to see and be notified about by email.

### Avaya IP Office Knowledge Base

<https://ipofficekb.avaya.com> provides access to an online, regularly updated version of the IP Office Knowledge Base.

### Avaya maintenance, lifecycle and warranty information

Avaya support services complement standard Avaya maintenance, lifecycle and warranty policies that are posted on <https://support.avaya.com>. For more information, send email to [support@avaya.com](mailto:support@avaya.com).

## **International Avaya User Group**

<https://www.iaug.org> is the official discussion forum for Avaya product users.

# Index

## Numerics

4400/6400 ..... [453](#)  
911–View ..... [1006](#)

## A

account code configuration ..... [683](#)  
account code configuration fields ..... [528](#)  
    voice recording ..... [528](#)  
advanced ..... [63](#)  
    erase configuration ..... [64](#)  
    reboot ..... [64](#)  
    system shutdown ..... [65](#)  
    upgrade ..... [66](#)  
        changing the .bin file directory ..... [68](#)  
        searching for systems ..... [68](#)  
advanced view ..... [81](#)  
alarms ..... [257](#)  
analog extension ..... [400](#)  
analog line ..... [280](#)  
    analog options ..... [283](#)  
    line settings ..... [281](#)  
announcements ..... [458](#)  
Apple  
    push notifications ..... [740, 741](#)  
ARS configuration fields ..... [558](#)  
audit trail ..... [69](#)  
authorization codes configuration fields ..... [548](#)  
auto attendant configuration fields ..... [543, 544](#)  
    actions ..... [546](#)  
autoconnect ..... [495](#)  
auto intercom deny off ..... [831](#)  
auto intercom deny on ..... [831](#)  
automatic  
    synchronization ..... [738](#)  
Avaya  
    cloud authorization ..... [739](#)

## B

backup/restore ..... [80](#)  
bandwidth ..... [491](#)  
barred calls ..... [659](#)  
    applying ..... [659](#)  
    overriding ..... [660](#)  
BOOTP record ..... [201](#)  
BRI line ..... [289](#)  
    channels ..... [294](#)  
busy on held validation ..... [84](#)  
button programming ..... [452](#)

## C

call log ..... [248, 444, 678](#)  
call logs ..... [681](#)  
Call Records ..... [1137](#)  
call scenarios ..... [680](#)  
call settings ..... [435](#)  
centralized ..... [678, 680, 681](#)  
centralized licensing ..... [569](#)  
certificate management ..... [581](#)  
    overview ..... [582](#)  
    windows certificate store ..... [583](#)  
certificates ..... [130](#)  
certificate support ..... [586](#)  
    file import ..... [592](#)  
    file naming and format ..... [586](#)  
    identity certificate ..... [587](#)  
    signing certificate ..... [591](#)  
    trusted certificate store ..... [589](#)  
change mode ..... [68](#)  
change working directory ..... [52](#)  
close configuration ..... [50](#)  
cloud ..... [738](#)  
    authorization ..... [738](#)  
codec selection ..... [777](#)  
configuration field  
    Access Control Lists ..... [274](#)  
    account code  
        voice recording ..... [528](#)  
    analog ..... [400](#)  
    analog line ..... [280](#)  
    analog line options ..... [283](#)  
    analog line settings ..... [281](#)  
    ARS ..... [558](#)  
    authorization codes ..... [548](#)  
    auto attendant  
        actions ..... [546](#)  
    BOOTP ..... [201](#)  
    BRI line ..... [289, 294](#)  
    call details ..... [348](#)  
    call log ..... [248](#)  
    control unit ..... [395](#)  
    customer call reporter ..... [268](#)  
    DHCP pools ..... [224](#)  
    dialer ..... [275](#)  
    directory ..... [518](#)  
    directory services ..... [251, 254](#)  
    display  
        server edition mode ..... [199](#)  
        standard mode ..... [198](#)  
    DNS ..... [226](#)  
    E1 line ..... [295](#)  
    E1 line channels ..... [302](#)

## Index

### WAN port (continued)

E1 R2 Advanced .....	<a href="#">308</a>
E1 R2 channels .....	<a href="#">306</a>
E1 R2 line .....	<a href="#">304</a>
E1 R2 MFC group .....	<a href="#">308</a>
extension .....	<a href="#">396</a> , <a href="#">397</a> , <a href="#">400</a> , <a href="#">403</a> , <a href="#">407</a> , <a href="#">410</a> , <a href="#">412</a> , <a href="#">413</a>
firewall profile	
custom .....	<a href="#">523</a>
standard .....	<a href="#">521</a>
static NAT .....	<a href="#">525</a>
group	
fallback .....	<a href="#">475</a>
overflow .....	<a href="#">473</a>
select members .....	<a href="#">469</a>
SIP .....	<a href="#">487</a>
voicemail .....	<a href="#">478</a>
voice recording .....	<a href="#">483</a>
H.323 line .....	<a href="#">328</a>
H.323 short codes .....	<a href="#">331</a>
H.323 VoIP .....	<a href="#">403</a>
H.323 VoIP settings .....	<a href="#">331</a>
incoming call route	
standard .....	<a href="#">507</a>
voice recording .....	<a href="#">511</a> , <a href="#">512</a>
IP DECT .....	<a href="#">412</a>
IP DECT gateway .....	<a href="#">335</a>
IP DECT line .....	<a href="#">334</a>
IP DECT VoIP .....	<a href="#">337</a>
IP Office line .....	<a href="#">384</a>
IP Office line short codes .....	<a href="#">390</a>
IP Office line T38 Fax .....	<a href="#">393</a>
IP Office line VoIP settings .....	<a href="#">390</a>
IP route	
RIP dynamic routing .....	<a href="#">527</a>
LAN1 .....	<a href="#">211</a>
LAN2 .....	<a href="#">225</a>
LAN settings .....	<a href="#">211</a>
LAN VoIP .....	<a href="#">213</a>
license	
remote server .....	<a href="#">534</a>
line .....	<a href="#">279</a>
location	
address .....	<a href="#">564</a>
network topology .....	<a href="#">221</a>
park and page .....	<a href="#">240</a>
PRI trunks .....	<a href="#">294</a>
remote access server	
PPP .....	<a href="#">503</a>
ring tones .....	<a href="#">245</a>
S0 line .....	<a href="#">325</a>
service .....	<a href="#">489</a> , <a href="#">490</a>
autoconnect .....	<a href="#">495</a>
bandwidth .....	<a href="#">491</a>
dial in .....	<a href="#">499</a>
fallback .....	<a href="#">498</a>
IP .....	<a href="#">493</a>
PPP .....	<a href="#">496</a>

### WAN port (continued)

service (continued)	
quota .....	<a href="#">495</a>
SSL VPN .....	<a href="#">499</a> , <a href="#">500</a>
SSL VPN fallback .....	<a href="#">502</a>
SSL VPN NAPT .....	<a href="#">501</a>
SSL VPN session .....	<a href="#">500</a>
short code .....	<a href="#">488</a>
shorty codes .....	<a href="#">427</a>
SIP advanced .....	<a href="#">367</a>
SIP credentials .....	<a href="#">366</a>
SIP DECT base .....	<a href="#">373</a> , <a href="#">413</a>
SIP DECT line .....	<a href="#">373</a>
SIP DECT VoIP .....	<a href="#">374</a>
SIP engineering .....	<a href="#">372</a>
SIP line .....	<a href="#">339</a>
SIP T38 Fax .....	<a href="#">365</a>
SIP transport .....	<a href="#">343</a>
SIP VoIP .....	<a href="#">360</a> , <a href="#">407</a>
SMDR .....	<a href="#">264</a>
SM line .....	<a href="#">375</a>
SM line T38 Fax .....	<a href="#">383</a>
SM line VoIP .....	<a href="#">378</a>
SMTP .....	<a href="#">263</a>
subscription .....	<a href="#">530</a>
system .....	<a href="#">203</a> , <a href="#">204</a>
system events .....	<a href="#">256</a>
system events alarms .....	<a href="#">257</a>
system events configuration .....	<a href="#">256</a>
System Manager .....	<a href="#">246</a>
T1 channels .....	<a href="#">312</a>
T1 line .....	<a href="#">310</a>
T1 PRI line .....	<a href="#">315</a>
T38 fax .....	<a href="#">410</a>
telephony .....	<a href="#">233</a>
time profile .....	<a href="#">519</a> , <a href="#">597</a>
tones and music .....	<a href="#">241</a>
TUI .....	<a href="#">249</a>
tunnel	
IP security tunnel .....	<a href="#">540</a>
IKE policies .....	<a href="#">541</a>
IPSec policies .....	<a href="#">542</a>
main .....	<a href="#">541</a>
L2TP tunnel .....	<a href="#">538</a> – <a href="#">540</a>
user .....	<a href="#">413</a> , <a href="#">414</a> , <a href="#">427</a>
announcements .....	<a href="#">458</a>
button programming .....	<a href="#">452</a>
dial in .....	<a href="#">449</a>
DND .....	<a href="#">426</a>
forwarding .....	<a href="#">446</a>
hunt group membership .....	<a href="#">458</a>
menu programming .....	<a href="#">453</a>
mobility .....	<a href="#">454</a>
personal directory .....	<a href="#">460</a>
self administration .....	<a href="#">462</a>
SIP .....	<a href="#">459</a>
source numbers .....	<a href="#">428</a>

WAN port (continued)

- user (continued)
  - telephony ..... [435](#)
  - voicemail ..... [421](#)
  - voice recording ..... [450](#)
- user rights
  - forwarding ..... [557](#)
  - telephony ..... [551](#)
  - user ..... [549](#)
  - user rights membership ..... [555](#), [556](#)
- voice compression modules ..... [266](#)
- voicemail ..... [226](#)
- VoIP ..... [269](#), [403](#)
- VoIP security ..... [271](#)
- WAN port
  - advanced ..... [517](#)
  - DLCI ..... [515](#)
  - frame relay ..... [515](#)

configuring

- automatic ..... [738](#)
- client ..... [738](#)
- token cache time ..... [740](#)

connect to ..... [83](#)

Contact Center ..... [277](#)

Contact field ..... [769](#)

controlling ..... [681](#)

control unit ..... [395](#)

create new config ..... [62](#)

customer call reporter ..... [268](#)

**D**

- destination URI ..... [768](#)
- details pane ..... [81](#), [97](#)
- details toolbar ..... [94](#)
- DHCP pools ..... [224](#)
- dialer ..... [275](#)
- dial in ..... [449](#)
- directories ..... [56](#)
- directory configuration fields ..... [251](#), [518](#)
- directory services
  - HTTP ..... [254](#)
  - LDAP ..... [251](#)
- discovery ..... [57](#)
- DNS ..... [226](#)
- do not disturb ..... [426](#)
- downloading
  - manager lite ..... [42](#)
- DTMF ..... [778](#)

**E**

- E1 line ..... [295](#)
  - channels ..... [302](#)
- E1 R2 line ..... [304](#)
  - Advanced ..... [308](#)
  - channels ..... [306](#)

E1 R2 line (continued)

- MFC group ..... [308](#)
- embedded file management ..... [70](#)
- embedded file management menus ..... [89](#)
- Emergency View ..... [1006](#)
- enabling
  - cloud account authorization ..... [739](#)
- erase configuration ..... [64](#)
- error pane ..... [81](#), [99](#)
  - automatic validation settings ..... [100](#)
  - revalidating settings ..... [100](#)
  - viewing error ..... [100](#)
- exit ..... [81](#)
- export user ..... [83](#)
- extension configuration fields ..... [396](#)
  - analog ..... [400](#)
  - extension ..... [397](#)
  - H.323 VoIP ..... [403](#)
  - IP DECT ..... [412](#)
  - SIP DECT base ..... [413](#)
  - SIP VoIP ..... [407](#)
  - T38 fax ..... [410](#)
  - VoIP ..... [403](#)
- extension renumber ..... [82](#)

**F**

- fallback ..... [475](#), [498](#)
- fax over SIP ..... [778](#)
- file menu ..... [49](#)
  - change working directory ..... [52](#)
  - close configuration ..... [50](#)
  - open configuration ..... [50](#)
  - save configuration ..... [50](#)
  - save configuration as ..... [52](#)
- firewall ..... [521](#)
  - custom ..... [523](#)
  - standard ..... [521](#)
  - static NAT ..... [525](#)
- firewall profile configuration fields ..... [521](#)
  - custom ..... [523](#)
  - standard ..... [521](#)
  - static NAT ..... [525](#)
- format SD card ..... [71](#)
- forwarding ..... [446](#)
- From field ..... [768](#)

**G**

- general security fields ..... [139](#)
- getting started ..... [40](#)
- Gmail integration ..... [668](#)
- group configuration fields ..... [465](#), [470](#)
  - fallback ..... [475](#)
  - overflow ..... [473](#)
  - select members ..... [469](#)
  - SIP ..... [487](#)

## Index

### group configuration fields (*continued*)

voicemail .....	<a href="#">478</a>
voice recording .....	<a href="#">483</a>
group operation .....	<a href="#">705</a>
group pane .....	<a href="#">81</a> , <a href="#">95</a>
add record .....	<a href="#">96</a>
columns displayed .....	<a href="#">96</a>
delete record .....	<a href="#">97</a>
show in groups .....	<a href="#">97</a>
sorting .....	<a href="#">95</a>
validate record .....	<a href="#">97</a>

## H

H.323 extension VoIP .....	<a href="#">403</a>
H.323 line .....	<a href="#">328</a>
short codes .....	<a href="#">331</a>
VoIP setting .....	<a href="#">331</a>
headers .....	<a href="#">785</a>
hold scenarios .....	<a href="#">778</a>
HTTP directory services .....	<a href="#">254</a>
huntgroup .....	<a href="#">453</a>
hunt group membership .....	<a href="#">458</a>

## I

### icons

changing size .....	<a href="#">104</a>
import/export .....	<a href="#">80</a>
import templates .....	<a href="#">86</a>
incoming call	
call scenarios .....	<a href="#">774</a>
message details .....	<a href="#">772</a>
routing .....	<a href="#">772</a>
incoming call route configuration fields .....	<a href="#">504</a>
standard .....	<a href="#">507</a>
voice recording .....	<a href="#">511</a> , <a href="#">512</a>
incoming calls	
media path connection .....	<a href="#">773</a>
initial configuration .....	<a href="#">75</a>
InSite Knowledge Base .....	<a href="#">1152</a>
IP DECT .....	<a href="#">412</a>
IP DECT gateway .....	<a href="#">335</a>
IP DECT line .....	<a href="#">334</a>
IP DECT VoIP .....	<a href="#">337</a>
IP Office line .....	<a href="#">384</a>
short codes .....	<a href="#">390</a>
VoIP settings .....	<a href="#">390</a>
IP Office line T38 Fax .....	<a href="#">393</a>
IP route	
configuring .....	<a href="#">653</a>
IP route configuration fields .....	<a href="#">525</a> , <a href="#">526</a>
RIP dynamic routing .....	<a href="#">527</a>
IP security tunnel .....	<a href="#">540</a>
IKE policies .....	<a href="#">541</a>
IPSec policies .....	<a href="#">542</a>
main .....	<a href="#">541</a>

## L

L2TP tunnel .....	<a href="#">538</a>
L2TP .....	<a href="#">539</a>
PPP .....	<a href="#">540</a>
LAN1 .....	<a href="#">211</a>
LAN2 .....	<a href="#">225</a>
LAN settings .....	<a href="#">211</a>
LAN VoIP .....	<a href="#">213</a>
launch Voicemail Pro .....	<a href="#">74</a>
LDAP directory services .....	<a href="#">251</a>
legal notices .....	<a href="#">4</a>
license	
configuring .....	<a href="#">567</a>
license configuration fields .....	<a href="#">531</a> , <a href="#">532</a>
remote server .....	<a href="#">534</a>
license file	
uploading .....	<a href="#">576</a>
license migration .....	<a href="#">87</a> , <a href="#">580</a>
licensing	
enterprise branch .....	<a href="#">579</a>
line configuration fields .....	<a href="#">279</a>
analog line .....	<a href="#">280</a>
analog line options .....	<a href="#">283</a>
analog line settings .....	<a href="#">281</a>
BRI line .....	<a href="#">289</a> , <a href="#">294</a>
control unit .....	<a href="#">395</a>
E1 line .....	<a href="#">295</a>
E1 line channels .....	<a href="#">302</a>
E1 R2 Advanced .....	<a href="#">308</a>
E1 R2 channels .....	<a href="#">306</a>
E1 R2 line .....	<a href="#">304</a>
E1 R2 MFC group .....	<a href="#">308</a>
H.323 line .....	<a href="#">328</a>
H.323 short codes .....	<a href="#">331</a>
H.323 VoIP setting .....	<a href="#">331</a>
IP DECT gateway .....	<a href="#">335</a>
IP DECT line .....	<a href="#">334</a>
IP DECT VoIP .....	<a href="#">337</a>
IP Office line .....	<a href="#">384</a>
IP Office line short codes .....	<a href="#">390</a>
IP Office line T38 Fax .....	<a href="#">393</a>
IP Office line VoIP settings .....	<a href="#">390</a>
PRI trunks .....	<a href="#">294</a>
S0 line .....	<a href="#">325</a>
SIP advanced .....	<a href="#">367</a>
SIP credentials .....	<a href="#">366</a>
SIP DECT base .....	<a href="#">373</a>
SIP DECT line .....	<a href="#">373</a>
SIP DECT VoIP .....	<a href="#">374</a>
SIP engineering .....	<a href="#">372</a>
SIP line .....	<a href="#">339</a>
SIP T38 Fax .....	<a href="#">365</a>
SIP transport .....	<a href="#">343</a>
SIP URI .....	<a href="#">348</a>
SIP VoIP .....	<a href="#">360</a>
SM line .....	<a href="#">375</a>

line configuration fields (*continued*)

- SM line T38 Fax ..... [383](#)
- SM line VoIP ..... [378](#)
- T1 channels ..... [312](#)
- T1 line ..... [310](#)
- T1 PRI line ..... [315](#)

line renumber ..... [82](#)

location

- address ..... [564](#)

location configuration fields ..... [562](#)

LVM greeting utility ..... [74](#)

**M**

madn ..... [1032](#)

main toolbar ..... [93](#)

Manager

- synchronize passwords ..... [744](#)

manager lite

- download ..... [42](#)

manager modes ..... [33](#)

media path connection ..... [773](#)

memory card command ..... [73](#)

menu bar commands ..... [49](#)

- advanced ..... [63–66, 68](#)
  - audit trail ..... [69](#)
  - change mode ..... [68](#)
  - embedded file management ..... [70](#)
  - erase security settings ..... [70](#)
  - format SD card ..... [71](#)
  - initial configuration ..... [75](#)
  - launch Voicemail Pro ..... [74](#)
  - LVM greeting utility ..... [74](#)
  - memory card command ..... [73](#)
  - recreate SD card ..... [72](#)
  - security settings ..... [70](#)
  - System Status ..... [74](#)
  - VM locales ..... [79](#)

backup/restore ..... [80](#)

embedded file management ..... [89](#)

exit ..... [81](#)

file ..... [49, 62–66, 68–75, 79–81](#)

file menu ..... [50, 52](#)

import/export ..... [80](#)

offline ..... [62, 63](#)

preferences ..... [53, 56–59, 62](#)

security mode ..... [88](#)

tools

- busy on held validation ..... [84](#)
- connect to ..... [83](#)
- export user ..... [83](#)
- extension renumber ..... [82](#)
- import templates ..... [86](#)
- license migration ..... [87](#)
- line renumber ..... [82](#)
- MSN configuration ..... [85](#)
- print button labels ..... [85](#)

tools (*continued*)

- tools (*continued*)
  - SCN service user management ..... [84](#)
  - view ..... [81](#)
- menu programming ..... [453](#)
- message waiting indication ..... [715](#)
- migrating ADI licenses ..... [580](#)
- mobility ..... [454](#)
- moving borders ..... [102](#)
- MSN configuration ..... [85](#)
- multiple call appearance ..... [1032](#)
- mult-line options ..... [442](#)
- music on hold
  - alternate source ..... [622](#)
  - system source ..... [622](#)

**N**

navigation pane ..... [81, 94](#)

navigation toolbar ..... [94](#)

network topology ..... [221](#)

new in release

- one-X resiliency ..... [750](#)
- resiliency ..... [750](#)

new in this release ..... [28, 30, 31](#)

NoCallerId alarm

- suppressing ..... [729](#)

notices, legal ..... [4](#)

No User ..... [728](#)

**O**

offline ..... [62](#)

- create new config ..... [62](#)
- open file ..... [62](#)
- open file set ..... [63](#)
- receive config ..... [63](#)
- send config ..... [63](#)

on-boarding: configuring SSL VPN ..... [595](#)

open configuration ..... [50](#)

open file ..... [62](#)

open file set ..... [63](#)

opening a configuration ..... [44](#)

- login messages ..... [45](#)

operator ..... [203](#)

Outbound Contact Express

- dialer ..... [275](#)

outgoing call

- call scenarios ..... [770](#)
- Contact field ..... [769](#)
- destination URI ..... [768](#)
- From field ..... [768](#)
- message details ..... [768](#)
- P-Asserted Identity field ..... [769](#)
- To field ..... [769](#)

overflow ..... [473](#)

overview ..... [33](#)

**P**

panes	
moving the details pane	<a href="#">103</a>
showing or hiding	<a href="#">103</a>
park and page	<a href="#">240</a>
P-Asserted Identity field	<a href="#">769</a>
PC requirements	<a href="#">40</a>
personal directory	<a href="#">460</a>
PLDS licensing	<a href="#">567</a>
preferences	<a href="#">53</a>
directories	<a href="#">56</a>
discovery	<a href="#">57</a>
preferences	<a href="#">53</a>
security	<a href="#">59</a>
validation	<a href="#">62</a>
visual preferences	<a href="#">58</a>
print button labels	<a href="#">85</a>
PRI trunks	<a href="#">294</a>
E1 line	<a href="#">295</a>
E1 line channels	<a href="#">302</a>
E1 R2 Advanced	<a href="#">308</a>
E1 R2 channels	<a href="#">306</a>
E1 R2 line	<a href="#">304</a>
E1 R2 MFC group	<a href="#">308</a>
T1 channels	<a href="#">312</a>
T1 line	<a href="#">310</a>
T1 PRI line	<a href="#">315</a>

**Q**

quota	<a href="#">495</a>
-------	---------------------

**R**

reboot	<a href="#">64</a>
receive config	<a href="#">63</a>
record consolidation	<a href="#">109</a>
recreate SD card	<a href="#">72</a>
remote access server configuration fields	<a href="#">502</a>
PPP	<a href="#">503</a>
remote server	<a href="#">534</a>
request methods	<a href="#">784</a>
resiliency	
location based	<a href="#">759</a>
resilience	<a href="#">746</a>
resiliency	<a href="#">746</a>
resizing the manager window	<a href="#">102</a>
resource websites	<a href="#">1153</a>
response methods	<a href="#">784</a>
RFC	<a href="#">783</a>
ring tones	<a href="#">245</a>
RIP dynamic routing	<a href="#">527</a>

**S**

S0 line	<a href="#">325</a>
save configuration	<a href="#">50</a>
save configuration as	<a href="#">52</a>
SCN service user management	<a href="#">84</a>
security field	<a href="#">138</a>
general	<a href="#">139</a>
rights groups	
configuration	<a href="#">156</a>
group details	<a href="#">156</a>
security administration	<a href="#">158</a>
services settings	<a href="#">154</a>
service users	<a href="#">162</a>
system	
certificates	<a href="#">148</a>
system details	<a href="#">145</a>
unsecured interfaces	<a href="#">147</a>
system status	
external	<a href="#">161</a>
HTTP	<a href="#">159</a>
security administration	<a href="#">158</a>
Telephony APIs	<a href="#">159</a>
web services	<a href="#">159</a>
security mode menus	<a href="#">88</a>
security preferences	<a href="#">59</a>
security settings	<a href="#">70</a>
erase	<a href="#">70</a>
self administration	<a href="#">462</a>
send config	<a href="#">63</a>
server edition	
default settings	<a href="#">108</a>
record consolidation	<a href="#">109</a>
solution view	<a href="#">105</a>
system inventories	<a href="#">108</a>
user interface	<a href="#">105</a>
server edition licenses	
distributing	<a href="#">569</a>
service	<a href="#">738</a>
service configuration fields	<a href="#">489</a> , <a href="#">490</a>
autoconnect	<a href="#">495</a>
bandwidth	<a href="#">491</a>
dial in	<a href="#">499</a>
fallback	<a href="#">498</a>
IP	<a href="#">493</a>
PPP	<a href="#">496</a>
quota	<a href="#">495</a>
SSL VPN	<a href="#">499</a> , <a href="#">500</a>
SSL VPN fallback	<a href="#">502</a>
SSL VPN NAPT	<a href="#">501</a>
SSL VPN session	<a href="#">500</a>
service users	<a href="#">113</a>
short code configuration fields	<a href="#">488</a>
short code feature	
auto intercom deny off	<a href="#">831</a>
auto intercom deny on	<a href="#">831</a>
short codes	<a href="#">427</a>



simplified view .....	<a href="#">81</a>	telephony ( <i>continued</i> ) .....	
SIP .....	<a href="#">459</a>	LAN settings .....	<a href="#">211</a>
SIP advanced .....	<a href="#">367</a>	LAN VoIP .....	<a href="#">213</a>
SIP credentials .....	<a href="#">366</a>	LDAP directory services .....	<a href="#">251</a>
SIP DECT base .....	<a href="#">413</a>	network topology .....	<a href="#">221</a>
SIP DECT line .....	<a href="#">373</a>	ring tones .....	<a href="#">245</a>
SIP DECT base .....	<a href="#">373</a>	SMDR .....	<a href="#">264</a>
SIP DECT VoIP .....	<a href="#">374</a>	SMTP .....	<a href="#">263</a>
SIP engineering .....	<a href="#">372</a>	system .....	<a href="#">204</a>
SIP extension VoIP .....	<a href="#">407</a>	system events .....	<a href="#">256</a>
SIP line .....	<a href="#">339</a>	system events alarms .....	<a href="#">257</a>
sip line appearances .....	<a href="#">356</a>	system events configuration .....	<a href="#">256</a>
SIP messaging .....	<a href="#">767</a>	System Manager .....	<a href="#">246</a>
SIP prefix .....	<a href="#">766</a>	telephony .....	<a href="#">233</a>
SIP REFER .....	<a href="#">780</a>	park and page .....	<a href="#">240</a>
SIP T38 Fax .....	<a href="#">365</a>	tones and music .....	<a href="#">241</a>
SIP transport .....	<a href="#">343</a>	TUI .....	<a href="#">249</a>
SIP trunk .....		voice compression modules .....	<a href="#">266</a>
configuring .....	<a href="#">762</a>	voicemail .....	<a href="#">226</a>
overview .....	<a href="#">761</a>	VoIP .....	<a href="#">269</a>
SIP trunks .....		VoIP security .....	<a href="#">271</a>
configuring .....	<a href="#">761</a>	system events .....	<a href="#">256, 655</a>
sip uri .....	<a href="#">349</a>	system events alarms .....	<a href="#">257</a>
SIP URI .....	<a href="#">348</a>	system events configuration .....	<a href="#">256</a>
SIP VoIP .....	<a href="#">360</a>	System Manager .....	<a href="#">246</a>
SMDR .....	<a href="#">264, 1137</a>	system security fields .....	<a href="#">145</a>
examples .....	<a href="#">1142</a>	certificates .....	<a href="#">148</a>
field descriptions .....	<a href="#">1139</a>	rights groups .....	
SM line .....	<a href="#">375</a>	configuration .....	<a href="#">156</a>
T38 Fax .....	<a href="#">383</a>	group details .....	<a href="#">156</a>
VoIP .....	<a href="#">378</a>	security administration .....	<a href="#">158</a>
SMTP .....	<a href="#">263</a>	services settings .....	<a href="#">154</a>
source numbers .....	<a href="#">428</a>	service users .....	<a href="#">162</a>
S RTP .....	<a href="#">133</a>	system details .....	<a href="#">145</a>
SSL VPN .....	<a href="#">499, 500</a>	system status .....	
SSL VPN fallback .....	<a href="#">502</a>	external .....	<a href="#">161</a>
SSL VPN NAPT .....	<a href="#">501</a>	HTTP .....	<a href="#">159</a>
SSL VPN session .....	<a href="#">500</a>	security administration .....	<a href="#">158</a>
Station Message Detail Reporting .....	<a href="#">1137</a>	Telephony APIs .....	<a href="#">159</a>
examples .....	<a href="#">1142</a>	web services .....	<a href="#">159</a>
field descriptions .....	<a href="#">1139</a>	unsecured interfaces .....	<a href="#">147</a>
status bar .....	<a href="#">101</a>	system shutdown .....	<a href="#">65</a>
subscription configuration fields .....	<a href="#">530</a>	System Status .....	<a href="#">74</a>
supervisors settings .....	<a href="#">438</a>		
system configuration field .....		<b>T</b> .....	
Avaya Cloud Services .....	<a href="#">278</a>	T1 line .....	<a href="#">310</a>
Contact Center .....	<a href="#">277</a>	channels .....	<a href="#">312</a>
system configuration fields .....	<a href="#">203</a>	T1 PRI line .....	<a href="#">315</a>
Access Control Lists .....	<a href="#">274</a>	T38 fax .....	<a href="#">410</a>
call log .....	<a href="#">248</a>	tabs .....	
customer call reporter .....	<a href="#">268</a>	changing display of .....	<a href="#">104</a>
DHCP pools .....	<a href="#">224</a>	telephony .....	<a href="#">233, 435</a>
dialer .....	<a href="#">275</a>	call log .....	<a href="#">248, 444</a>
DNS .....	<a href="#">226</a>	call settings .....	<a href="#">435</a>
HTTP directory services .....	<a href="#">254</a>	multi-line options .....	<a href="#">442</a>
LAN1 .....	<a href="#">211</a>	park and page .....	<a href="#">240</a>
LAN2 .....	<a href="#">225</a>		

## Index

telephony ( <i>continued</i> )		telephony ( <i>continued</i> )	
ring tones .....	<a href="#">245</a>	telephony ( <i>continued</i> )	
supervisor settings .....	<a href="#">438</a>	call log .....	<a href="#">444</a>
System Manager .....	<a href="#">246</a>	call settings .....	<a href="#">435</a>
tones and music .....	<a href="#">241</a>	multi-line options .....	<a href="#">442</a>
TUI .....	<a href="#">249, 445</a>	supervisor settings .....	<a href="#">438</a>
template		TUI .....	<a href="#">445</a>
analog trunk .....	<a href="#">603</a>	user .....	<a href="#">414</a>
creating .....	<a href="#">602</a>	voicemail .....	<a href="#">421</a>
templates		voice recording .....	<a href="#">450</a>
creating a new record from a template .....	<a href="#">602</a>	user interface .....	<a href="#">92</a>
TFTP log .....	<a href="#">81</a>	configuring	
time profile configuration fields .....	<a href="#">519, 597</a>	icon size .....	<a href="#">104</a>
title bar .....	<a href="#">92</a>	moving borders .....	<a href="#">102</a>
To field .....	<a href="#">769</a>	moving the details pane .....	<a href="#">103</a>
tones and music .....	<a href="#">241</a>	moving toolbars .....	<a href="#">103</a>
toolbars .....	<a href="#">81, 92</a>	resizing the manager window .....	<a href="#">102</a>
details .....	<a href="#">94</a>	showing or hiding panes .....	<a href="#">103</a>
main .....	<a href="#">93</a>	showing or hiding toolbars .....	<a href="#">102</a>
moving .....	<a href="#">103</a>	tab display .....	<a href="#">104</a>
navigation .....	<a href="#">94</a>	default settings .....	<a href="#">108</a>
showing or hiding .....	<a href="#">102</a>	details pane .....	<a href="#">97</a>
tools menu .....	<a href="#">82</a>	error pane .....	<a href="#">99</a>
tooltip .....	<a href="#">81</a>	automatic validation settings .....	<a href="#">100</a>
transport protocols .....	<a href="#">784</a>	revalidating settings .....	<a href="#">100</a>
trunk templates .....	<a href="#">600</a>	viewing error .....	<a href="#">100</a>
applying a template to an analog trunk .....	<a href="#">604</a>	group pane .....	<a href="#">95</a>
importing .....	<a href="#">601</a>	add record .....	<a href="#">96</a>
TUI .....	<a href="#">249, 445</a>	columns displayed .....	<a href="#">96</a>
tunnel configuration fields .....	<a href="#">537–542</a>	delete record .....	<a href="#">97</a>
twinning .....	<a href="#">454, 723</a>	show in groups .....	<a href="#">97</a>
		sorting .....	<a href="#">95</a>
		validate record .....	<a href="#">97</a>
		navigation pane .....	<a href="#">94</a>
		server edition .....	<a href="#">105, 108</a>
		solution view .....	<a href="#">105</a>
		status bar .....	<a href="#">101</a>
		system inventories .....	<a href="#">108</a>
		title bar .....	<a href="#">92</a>
		toolbars .....	<a href="#">92</a>
		toolbars	
		details .....	<a href="#">94</a>
		main .....	<a href="#">93</a>
		navigation .....	<a href="#">94</a>
		user management overview .....	<a href="#">663</a>
		user rights configuration fields .....	<a href="#">549</a>
		forwarding .....	<a href="#">557</a>
		telephony .....	<a href="#">551</a>
		call log .....	<a href="#">554</a>
		call settings .....	<a href="#">551</a>
		multi-line options .....	<a href="#">554</a>
		supervisor settings .....	<a href="#">552</a>
		user .....	<a href="#">549</a>
		user rights membership .....	<a href="#">555, 556</a>
<b>U</b>			
upgrade .....	<a href="#">66</a>		
changing the .bin file directory .....	<a href="#">68</a>		
searching for systems .....	<a href="#">68</a>		
user .....	<a href="#">414</a>		
No User .....	<a href="#">728, 729</a>		
suppressing NoCallerId alarm .....	<a href="#">729</a>		
user configuration fields .....	<a href="#">413</a>		
announcements .....	<a href="#">458</a>		
button programming .....	<a href="#">452</a>		
dial in .....	<a href="#">449</a>		
DND .....	<a href="#">426</a>		
forwarding .....	<a href="#">446</a>		
hunt group membership .....	<a href="#">458</a>		
menu programming .....	<a href="#">453</a>		
4400/6400 .....	<a href="#">453</a>		
huntgroup .....	<a href="#">453</a>		
mobility .....	<a href="#">454</a>		
personal directory .....	<a href="#">460</a>		
self administration .....	<a href="#">462</a>		
short codes .....	<a href="#">427</a>		
SIP .....	<a href="#">459</a>		
source numbers .....	<a href="#">428</a>		
telephony .....	<a href="#">435</a>		

**V**

validation preferences .....	<a href="#">62</a>
videos .....	<a href="#">1152</a>
visual preferences .....	<a href="#">58</a>
VM locales .....	<a href="#">79</a>
voice compression modules .....	<a href="#">266</a>
voicemail .....	<a href="#">226</a> , <a href="#">421</a> , <a href="#">478</a>
voice recording .....	<a href="#">450</a> , <a href="#">483</a> , <a href="#">511</a> , <a href="#">512</a> , <a href="#">528</a>
VoIP .....	<a href="#">269</a> , <a href="#">274</a>
VoIP security .....	<a href="#">271</a>

**W**

WAN port configuration fields .....	<a href="#">514</a>
advanced .....	<a href="#">517</a>
DLCI .....	<a href="#">515</a>
frame relay .....	<a href="#">515</a>
Web License Manager .....	<a href="#">568</a>
WebLM .....	<a href="#">568</a>
installing a license file .....	<a href="#">575</a>
WebLM host ID .....	<a href="#">575</a>